

Specifications

For other materials or modifications, please consult TESCOM.

OPERATING PARAMETERS

Pressure rating per criteria of ANSI/ASME B31.3

98-1010 Mini In-Line Series

Maximum Rated Operating Pressure

6000 psig / 414 bar

Design Maximum Proof Pressure

9000 psig / 621 bar

Materials of Construction

Body: 304 Stainless Steel

Internal Filter - 10 micron: Pleated 304 Stainless Steel

Porting

See Part Number Selector

Operating Temperature

-320°F to 550°F / -196°C to 288°C

98-1110 TEE-Type Series

Maximum Rated Operating Pressure

6000-10,000 psig / 414-690 bar

Design Maximum Proof Pressure

9000-15,000 psig / 621-1034 bar

Materials of Construction

Body: 303 Stainless Steel

Internal Filter - 10 micron: Pleated 304 Stainless Steel

O-rings: Buna, Teflon®, or Viton®

Porting

See Part Number Selector

Operating Temperature

Buna O-ring: -20°F to 165°F / -29°C to 74°C

Teflon® O-ring: -40°F to 165°F / -40°C to 74°C

Viton® O-ring: 0°F to 220°F / -18°C to 104°C

98-1210 In-Line Series

Maximum Rated Operating Pressure

3000-10,000 psig / 207-690 bar

Design Maximum Proof Pressure

4500-15,000 psig / 310-1034 bar

Materials of Construction

Body

3000 psig / 207 bar: 303 Stainless Steel

6000 and 10,000 psig / 414 and 690 bar: 17-4 Stainless Steel

Internal Filter, 10 micron: Pleated 304 Stainless Steel

O-rings: Buna, Teflon®, or Viton®

Porting

See Part Number Selector

Operating Temperature

Buna O-ring: -20°F to 165°F / -29°C to 74°C

Teflon® O-ring: -40°F to 165°F / -40°C to 74°C

Viton® O-ring: 0°F to 220°F / -18°C to 104°C

Ethylene Propylene O-ring: -40°F to 225°F / -40°C to 107°C

Teflon® and Viton® are registered trademarks of E.I. du Pont de Nemours and Company.



TESCOM 98 Series high pressure filters offer operating pressure ratings up to 10,000 psig / 690 bar with Mini In-line and TEE-Type designs.

Application

- Filtration prior to pressure control components, protects from particulate contamination

Features and Benefits

- Operating pressure ratings up to 10,000 psig / 690 bar
- In-line, Mini In-line and TEE-Type styles
- Pleated, 10 micron, 304 Stainless Steel internal filter material for maximum contaminant control
- Cleanable element reduces operating cost

98 SERIES FILTERS

98 Series Drawings

98-1010 SERIES MINI IN-LINE

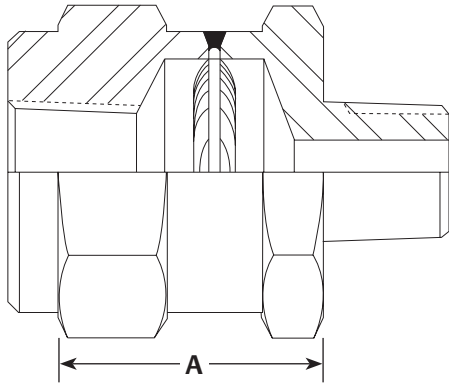

PART NUMBER	DIMENSION A
98-1010-T-2PM	1.10"
98-1010-T-2PP	1.58"
98-1010-T-2BT	1.10"
98-1010-T-3PP	1.58"
98-1010-T-3BT	1.10"
98-1010-T-4PM	1.42"
98-1010-T-4PP	1.58"
98-1010-T-4BT	1.10"

98-1110 SERIES TEE-TYPE

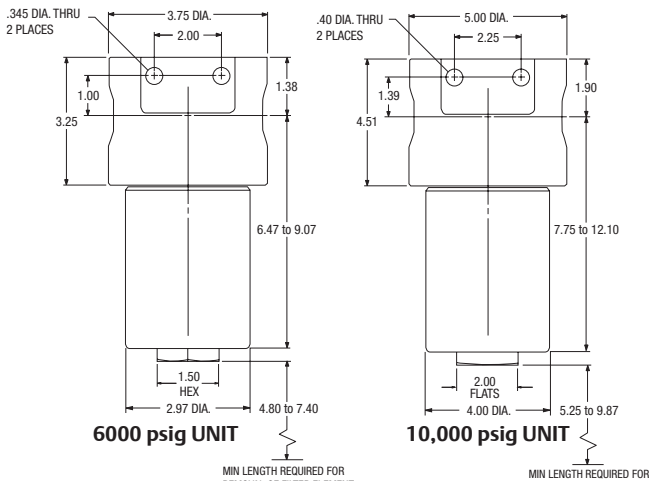

PART NUMBER	DIAMETER	LENGTH	ELEMENT REPLACEMENT
98-1110-T-2P	3.75"	7.85"	61667-1
98-1110-T-2B	3.75"	7.85"	61667-1
98-1110-T-2F	3.75"	7.85"	61667-1
98-1110-T-3P	3.75"	7.85"	61667-1
98-1110-T-3B	3.75"	7.85"	61667-1
98-1110-T-3F	3.75"	7.85"	61667-1
98-1110-T-4P	3.75"	7.85"	61667-1
98-1110-T-4B	3.75"	7.85"	61667-1
98-1110-T-4F	3.75"	7.85"	61667-1
98-1110-S-2P	5.00"	9.65"	61667-1
98-1110-S-2B	5.00"	9.65"	61667-1
98-1110-S-2F	5.00"	9.65"	61667-1
98-1110-S-3P	5.00"	9.65"	61667-1
98-1110-S-3B	5.00"	9.65"	61667-1
98-1110-S-3F	5.00"	9.65"	61667-1
98-1110-S-4P	5.00"	9.65"	61667-1
98-1110-S-4B	5.00"	9.65"	61667-1
98-1110-S-4F	5.00"	9.65"	61667-1

1. See O-ring material table on page 6.

98-1210 SERIES IN-LINE

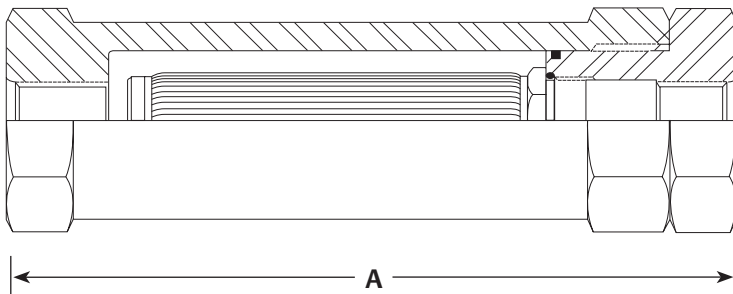

All dimensions are reference & nominal

PART NUMBER	DIMENSION A	ELEMENT REPLACEMENT
98-1210-U-2PP	6.00"	61666-413
98-1210-U-2BB	4.19"	61666-411
98-1210-U-4PP	7.75"	61666-415
98-1210-U-4BB	6.00"	61666-413
98-1210-T-2PP	6.00"	61666-413
98-1210-T-2BB	4.19"	61666-411
98-1210-T-4PP	7.75"	61666-415
98-1210-T-4BB	6.00"	61666-413
98-1210-S-2BB	4.19"	61666-411
98-1210-S-2PP	6.00"	61666-411

98 Series Flow Charts

For more information on how to read flow curves, please refer to the Flow Curves and Calculations document (debul2007x012) in the TESCOM catalog or on www.tescom.com.

98-1010 SERIES MINI IN-LINE

Typical Flow Curve - Oil
98-1010 (10 Micron nominal)
100 Saubolt Second Unit

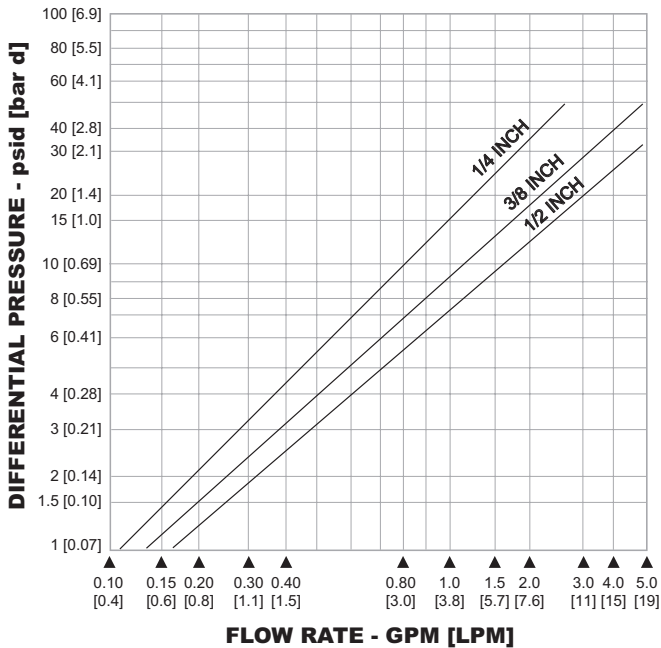

Typical Flow Curve - Air
98-1010 (10 Micron nominal)
100 psi inlet

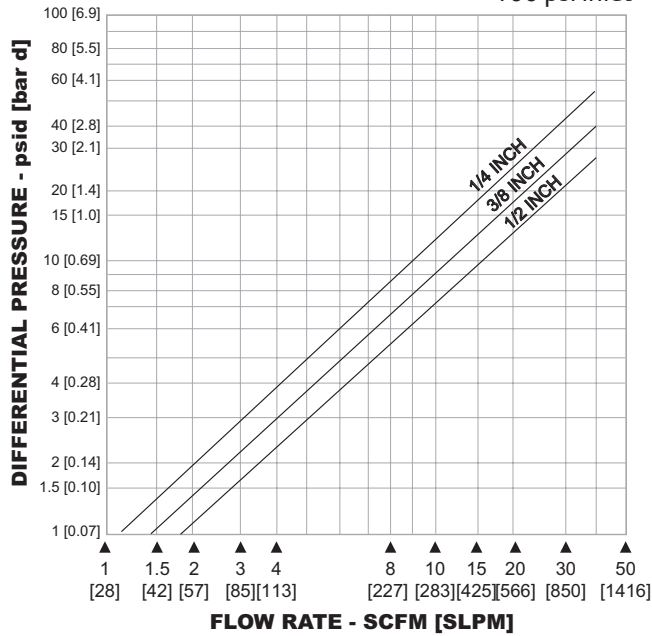

98-1110 SERIES TEE-TYPE

Filter Assembly Less Element

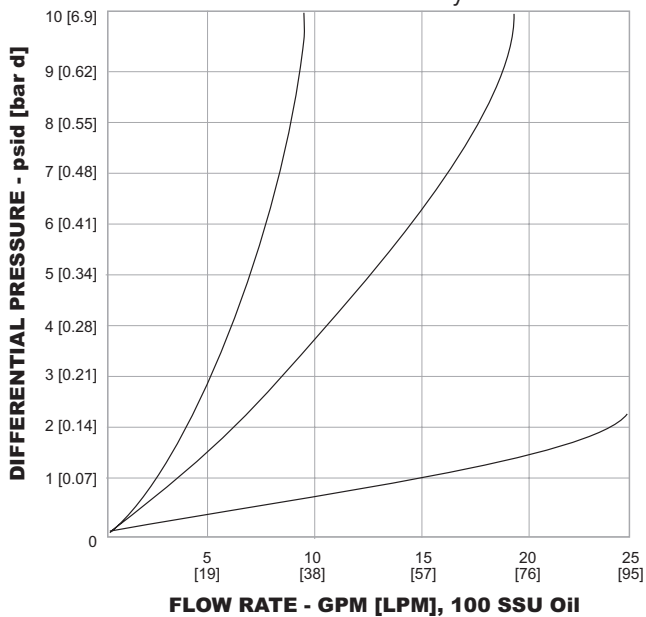

61667 Series Stainless Elements

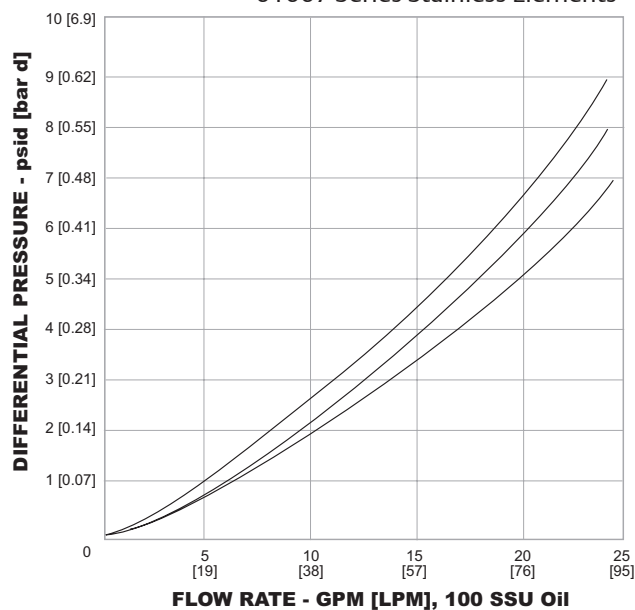

98 SERIES FILTERS

98 Series Flow Charts

For more information on how to read flow curves, please refer to the Flow Curves and Calculations document (debul2007x012) in the TESCOM catalog or on www.tescom.com.

98-1210 SERIES IN-LINE

AIR 3000 PSI

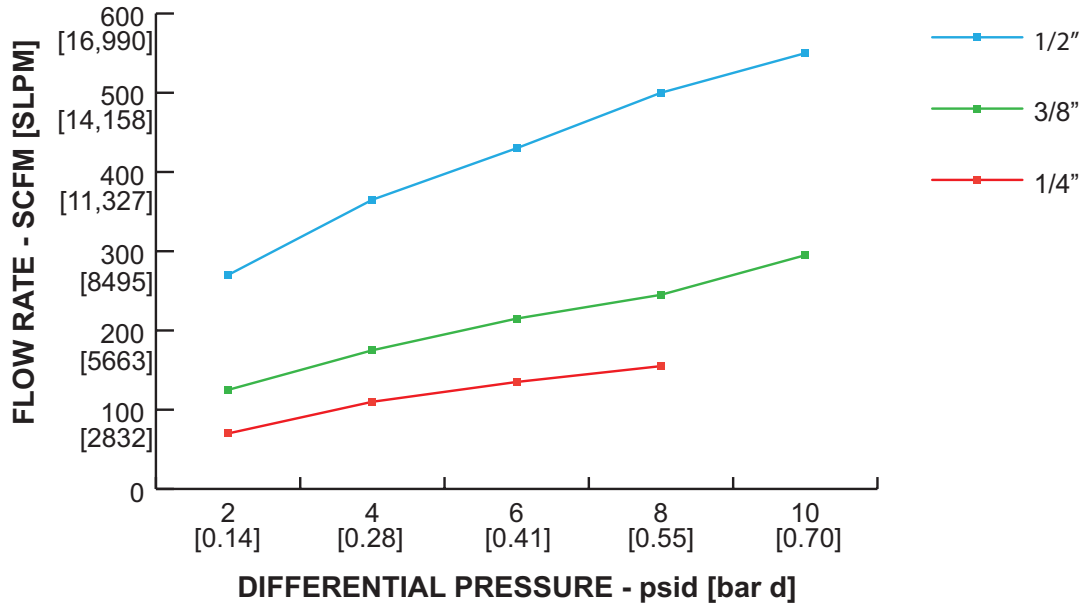

OIL 150 SSU

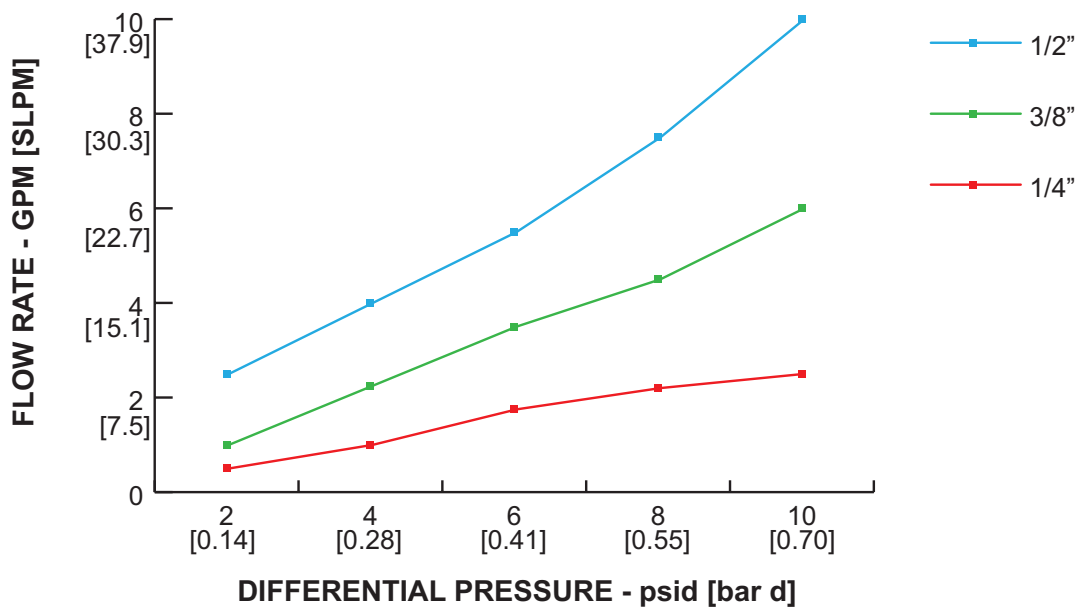

98 Series Optional Accessories

CODE R

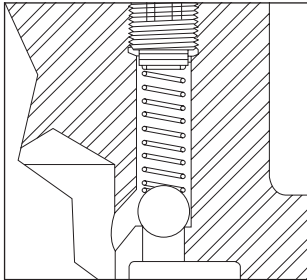

CODE R - Bypass Relief Valve

At a predetermined setting, the system fluid bypasses the element assembly until the element is either cleaned or replaced. Standard setting: 50 psid / 3.4 bar d cracking pressure.

CODE V

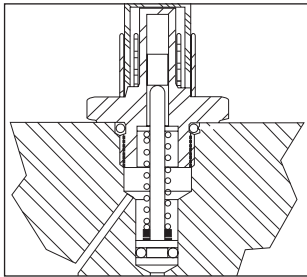

CODE V - Δ P Indicator

A Visual Differential Pressure Indicator enables an operator to read contaminant buildup before the element is plugged. The indicator is mounted on the head of the filter unit. It has an automatic reset. Stainless steel construction is standard. Standard setting is 40 psid / 2.8 bar d.

CODE E

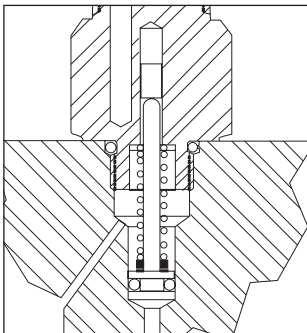

CODE E - Electrical Δ P Indicator

This electrical Visual Differential Pressure Indicator is ideal for applications where visual inspections are difficult due to location or when centralized process equipment monitoring is desired. By wiring the indicator into a central control panel, the filter can be remotely monitored quickly and easily. The Electrical Δ P Indicator is designed to be mounted on top of the filter unit. It is constructed of 303 Stainless Steel. An adjustable electric, normally open, reed switch Δ P indicator can operate signal devices. The contacts close when the Δ P increases and automatically resets when Δ P decreases. There is a 3/4" male pipe connection for the electrical hook-up. Voltage requirements: 10W-DC resistive 110 VA-AC resistive. The switch current is 0.5 amps. Relay required for heavier loads.

98 SERIES FILTERS

98 Series Part Number Selector

Repair Kits, Accessories & Modifications may be available for this product. Please contact TESCOM for more information.

Example for selecting a part number:

98-1010 SERIES MINI IN-LINE

98-1010 - T - 2 PP

BASIC SERIES	PRESSURE RATING	INLET PORT SIZE	INLET AND OUTLET PORT TYPE
98-1010	T – 6000 psig / 414 bar	2 – 1/4" 3 – 3/8" 4 – 1/2"	PP – Female NPTF PM – Female/Male NPTF (1/4" and 1/2" only) BT – MS33649 Female/MS33656 Male

98-1110 SERIES TEE-TYPE

98-1110 - T - 2 B - L VR

BASIC SERIES	PRESSURE RATING	INLET PORT SIZE	INLET AND OUTLET PORT TYPE	O-RING MATERIAL ¹	HOUSING OPTIONS
98-1110	T – 6000 psig 414 bar S – 10,000 psig 690 bar	2 – 1/4" 3 – 3/8" 4 – 1/2"	P – Female NPTF B – MS33649 F – SAE	STANDARD: L – Nitrile, Buna-N OPTIONAL: N – PTFE M – FKM (Viton®-A)	E – Electrical V – Visual R – Bypass Valve VR – Visual ΔP Indicator and Bypass Relief Valve ER – Electrical/Bypass
1. See SPECIFICATIONS for operating temperatures for O-rings.					

98-1210 SERIES IN-LINE

98-1210 - U - 2 BB - L

BASIC SERIES	PRESSURE RATING	INLET PORT SIZE	INLET AND OUTLET PORT TYPE	O-RING MATERIAL ¹
98-1210	U – 3000 psig 207 bar T – 6000 psig 414 bar S – 10,000 psig 690 bar	2 – 1/4" 3 – 3/8" 4 – 1/2" (3000 and 6000 psig / 207 and 414 bar only)	PP – Female NPTF BB – Male MS33649	STANDARD: L – Nitrile, Buna-N OPTIONAL: N – PTFE M – FKM (Viton®-A) Z – Ethylene Propylene
1. See SPECIFICATIONS for operating temperatures for O-rings.				