

## BR45 Hydraulic Breaker

81140 User Manual 04/2024 Ver. 26

<p><b>DECLARATION OF CONFORMITY ÜBEREINSTIMMUNGS-ERKLÄRUNG DECLARATION DE CONFORMITE CEE DECLARACION DE CONFORMIDAD DICHIARAZIONE DI CONFORMITA</b></p>	<p><b>STANLEY</b></p> <p><b>CE</b></p>																											
<p>I, the undersigned: Ich, der Unterzeichnende: Je soussigné: El abajo firmante: Io sottoscritto:</p>	<p><b>Vervier, Patrick</b></p> <p><small>Surname and First names/Familiennname und Vornamen/Nom et prénom/Nombre y apellido/Cognome e nome</small></p>																											
<p><b>hereby declare that the equipment specified hereunder: bestätige hiermit, daß erklaren Produkt genannten Werk oder Gerät: déclare que l'équipement visé ci-dessous: Por la presente declaro que el equipo se especifica a continuación: Dichiaro che le apparecchiature specificate di seguito:</b></p>																												
<p>1. Category: Kategorie: Catégorie: Categoria: Categoría:</p>	<p><b>Hydraulic Hand-Held Concrete Breaker</b></p>																											
<p>2. Make/Marke/Marque/Marca/Marca</p>	<p><b>STANLEY</b></p>																											
<p>3. Type/Typ/Type/Tipo/Tipo:</p>	<p><b>BR4514801, BR4516801, BR4516807, BR4516807A BR4556801, (BR45350 – For Underwater Use Only)</b></p>																											
<p>4. Serial number of equipment: Seriennummer des Geräts: Numéro de série de l'équipement: Numero de serie del equipo: Matricola dell'attrezzatura:</p>	<table border="1" style="margin: auto;"> <tr> <td><b>BR4514801</b></td> <td><b>All</b></td> </tr> <tr> <td><b>BR4514801A</b></td> <td><b>All</b></td> </tr> <tr> <td><b>BR4516801</b></td> <td><b>All</b></td> </tr> <tr> <td><b>BR4516807</b></td> <td><b>All</b></td> </tr> <tr> <td><b>BR4556801</b></td> <td><b>All</b></td> </tr> <tr> <td><b>BR45350</b></td> <td><b>Serial # 030612029 and above (For Underwater Use Only)</b></td> </tr> </table>	<b>BR4514801</b>	<b>All</b>	<b>BR4514801A</b>	<b>All</b>	<b>BR4516801</b>	<b>All</b>	<b>BR4516807</b>	<b>All</b>	<b>BR4556801</b>	<b>All</b>	<b>BR45350</b>	<b>Serial # 030612029 and above (For Underwater Use Only)</b>															
<b>BR4514801</b>	<b>All</b>																											
<b>BR4514801A</b>	<b>All</b>																											
<b>BR4516801</b>	<b>All</b>																											
<b>BR4516807</b>	<b>All</b>																											
<b>BR4556801</b>	<b>All</b>																											
<b>BR45350</b>	<b>Serial # 030612029 and above (For Underwater Use Only)</b>																											
<p>5. Mass/Masse/Masse/Masa/Massa 23 kg <b>Has been manufactured in conformity with Wurde hergestellt in Übereinstimmung mit Est fabriqué conformément Ha sido fabricado de acuerdo con E' stata costruita in conformità con</b></p>																												
<table border="1" style="width: 100%; border-collapse: collapse;"> <thead> <tr> <th style="width: 30%;">Directive/Standards Richtlinie/Standards Directives/Normes Directriz/Los Normas Direttiva/Norme</th> <th style="width: 20%;">No. Nr Numéro No n.</th> <th style="width: 50%;">Approved body Prüfung durch Organisme agréé Aprobado Collaudato</th> </tr> </thead> <tbody> <tr> <td>EN ISO</td> <td>4413:2010</td> <td>Self</td> </tr> <tr> <td>EN ISO</td> <td>12100:2010</td> <td>Self</td> </tr> <tr> <td>EN ISO</td> <td>28927-10:2011</td> <td>Self</td> </tr> <tr> <td>Noise Directive</td> <td>2000/14/EC:2005</td> <td>TUV Rheinland (Notified body ID 0197) Tillystraße 2, 90431 Nürnberg, Germany</td> </tr> <tr> <td>EN ISO</td> <td>3744:2010</td> <td>Certificate #JO601591860001 (Verification 09/11/2021) Valid: 8/11/2026</td> </tr> <tr> <td>EN ISO</td> <td>11148-4:2012</td> <td>Self</td> </tr> <tr> <td>EN ISO</td> <td>13732-1:2008</td> <td>Self</td> </tr> <tr> <td>Machinery Directive</td> <td>2006/42/EC:2006</td> <td>Self</td> </tr> </tbody> </table>		Directive/Standards Richtlinie/Standards Directives/Normes Directriz/Los Normas Direttiva/Norme	No. Nr Numéro No n.	Approved body Prüfung durch Organisme agréé Aprobado Collaudato	EN ISO	4413:2010	Self	EN ISO	12100:2010	Self	EN ISO	28927-10:2011	Self	Noise Directive	2000/14/EC:2005	TUV Rheinland (Notified body ID 0197) Tillystraße 2, 90431 Nürnberg, Germany	EN ISO	3744:2010	Certificate #JO601591860001 (Verification 09/11/2021) Valid: 8/11/2026	EN ISO	11148-4:2012	Self	EN ISO	13732-1:2008	Self	Machinery Directive	2006/42/EC:2006	Self
Directive/Standards Richtlinie/Standards Directives/Normes Directriz/Los Normas Direttiva/Norme	No. Nr Numéro No n.	Approved body Prüfung durch Organisme agréé Aprobado Collaudato																										
EN ISO	4413:2010	Self																										
EN ISO	12100:2010	Self																										
EN ISO	28927-10:2011	Self																										
Noise Directive	2000/14/EC:2005	TUV Rheinland (Notified body ID 0197) Tillystraße 2, 90431 Nürnberg, Germany																										
EN ISO	3744:2010	Certificate #JO601591860001 (Verification 09/11/2021) Valid: 8/11/2026																										
EN ISO	11148-4:2012	Self																										
EN ISO	13732-1:2008	Self																										
Machinery Directive	2006/42/EC:2006	Self																										
<p>6. Special Provisions: <b>None</b> Spezielle Bestimmungen: Dispositions particulières: Provisiones especiales: Disposizioni speciali:</p>	<p>7. Measurements: <b>Measured Sound Power Level 105 LwA Guaranteed Sound Power Level 107 LwA</b> Messungen Mesures Mediciones Misurazioni Measured in accordance to Directive 2000/14/EC, Annex III, Part B, No 10, 15 kg&lt;m&lt; 30 kg</p>																											
<p>8. Representative in the Union: <b>Patrick Vervier, STANLEY Dubuis 17-19, rue Jules Berthonneau- CS 73406 41034 Blois CEDEX, France.</b> Vertreter in der Union/Représentant dans l'union/Representante en la Union/Rappresentante presso l'Unione</p>																												
<p>Done at/Ort/Fait à/Dado en/Fatto a <u>STANLEY, Milwaukie, Oregon USA</u> Date/Datum/le/Fecha/Data</p>																												
<p>Signature/Unterschrift/Signature/Firma/Firma</p>																												
<p>Position/Position/Fonction/Cargo/Posizione, <u>Engineering Manager</u></p>																												

# DECLARATION OF CONFORMITY

# STANLEY®

# UK CA

I, the undersigned:

**Vervier, Patrick**

Surname and First names

hereby declare that the equipment specified hereunder:

- 1. Category: **Hydraulic Hand-Held Concrete Breaker**
- 2. Make: **STANLEY**
- 3. Type: **BR4514801, BR4516801, BR4516807, BR4516807A  
BR4556801, (BR45350 – For Underwater Use Only)**
- 4. Serial number of equipment:

<b>BR4514801</b>	<b>All</b>
<b>BR4514801A</b>	<b>All</b>
<b>BR4516801</b>	<b>All</b>
<b>BR4516807</b>	<b>All</b>
<b>BR4556801</b>	<b>All</b>
<b>BR45350</b>	<b>Serial # 030612029 and above (For Underwater Use Only)</b>

- 5. Mass : 23 kg

Has been manufactured in conformity with

Directive/Standards	No.	Approved body
EN ISO EN ISO EN ISO Noise Emission in the Environment by Equipment for Use Outdoors Regulations 2001 EN ISO	4413:2010 12100:2010 28927-10:2011 S.I. 2001/1701  3744:2010	Self Self Self TUV Rheinland (Notified body ID 0197) Tillystraße 2, 90431 Nürnberg, Germany Certificate #JO601591860001 (Verification 09/11/2021) Valid: 8/11/2026
EN ISO EN ISO Supply of Machinery (Safety) Regulations 2008	11148-4:2012 13732-1:2008 S.I. 2008/1597	Self Self Self

- 6. Special Provisions: **None**
- 7. Measurements: **Measured Sound Power Level 105 LwA  
Guaranteed Sound Power Level 107 LwA**  
Measured in accordance to Directive 2000/14/EC,  
Annex III, Part B, No 10, 15 kg<m< 30 kg
- 8. Representative in the Union: **Patrick Vervier, STANLEY Dubuis 17-19, rue Jules Berthonneau- CS 73406 41034 Blois CEDEX, France.**

Done at STANLEY, Milwaukie, Oregon USA Date \_\_\_\_\_

Signature

Position Engineering Manager

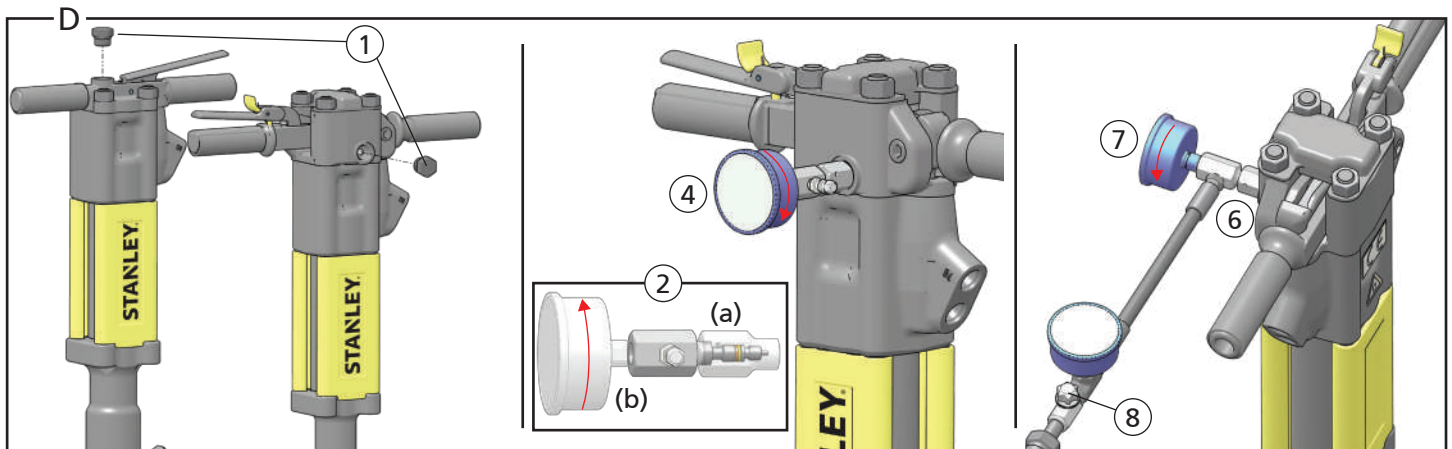
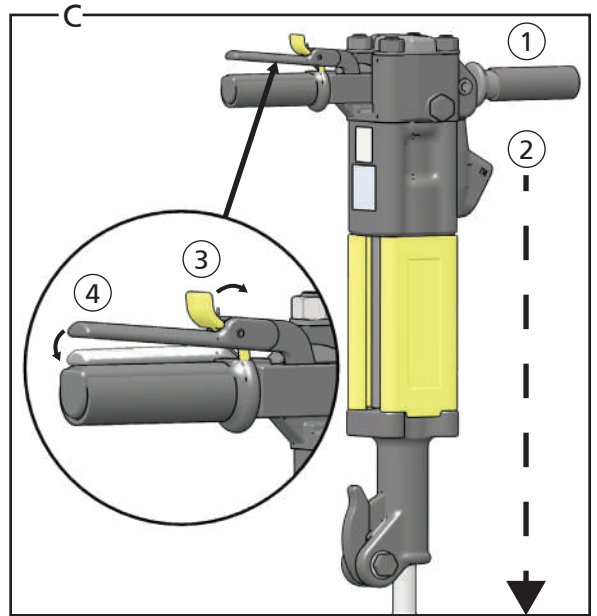
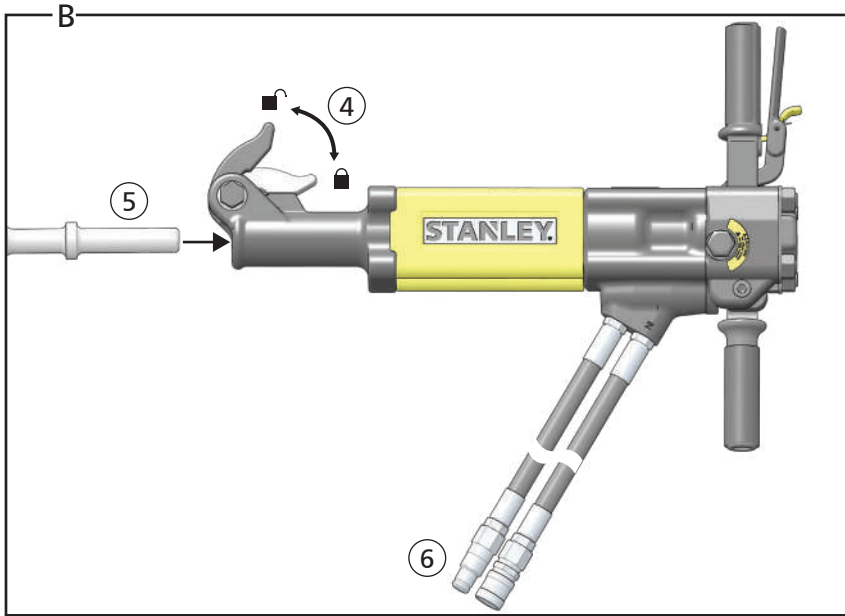
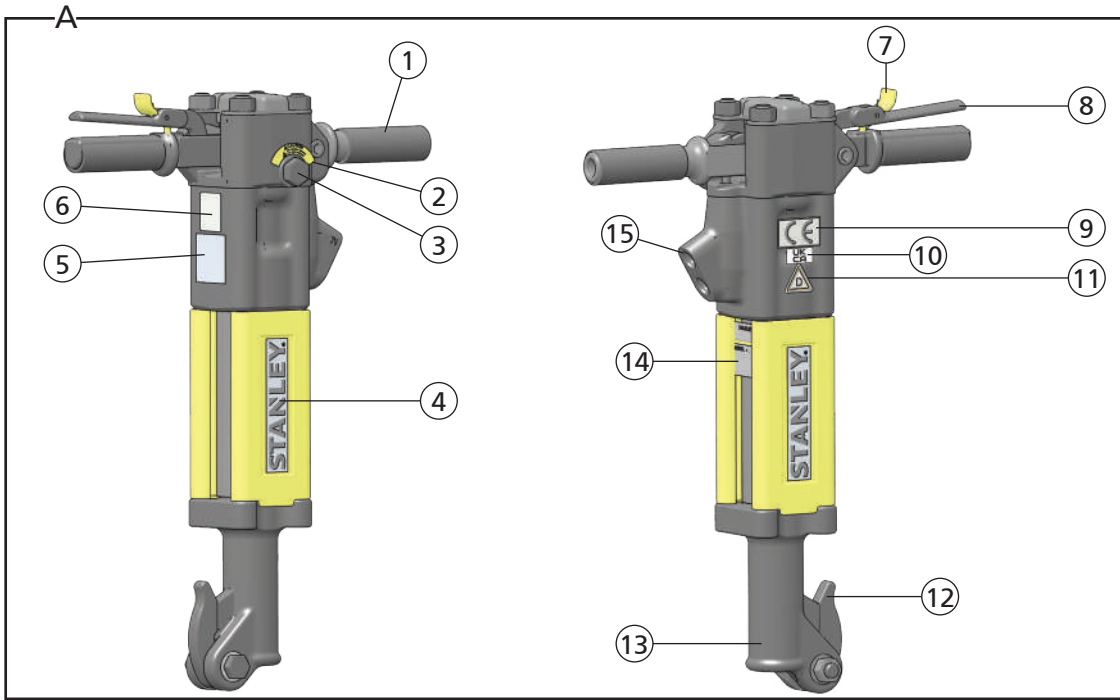

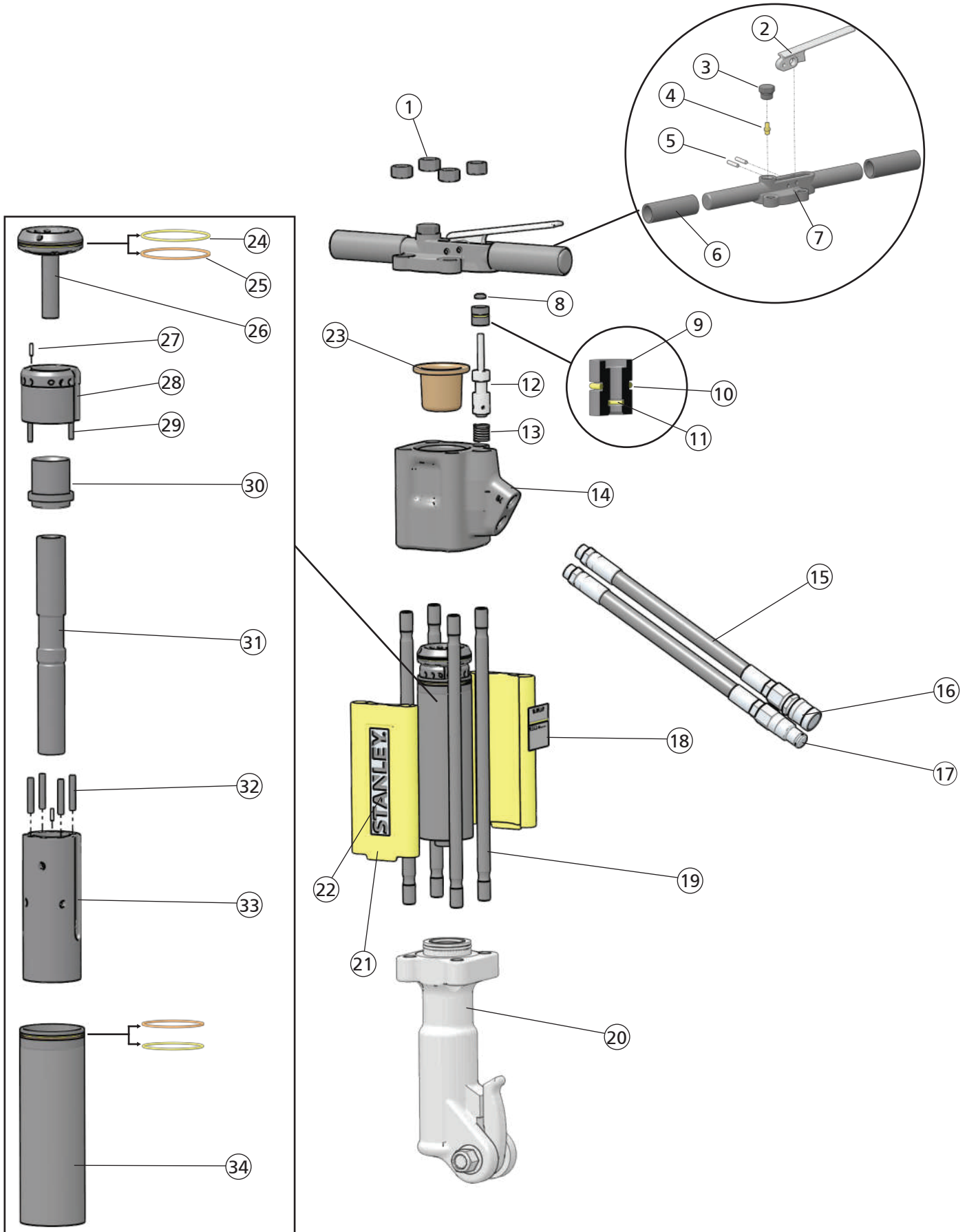

F

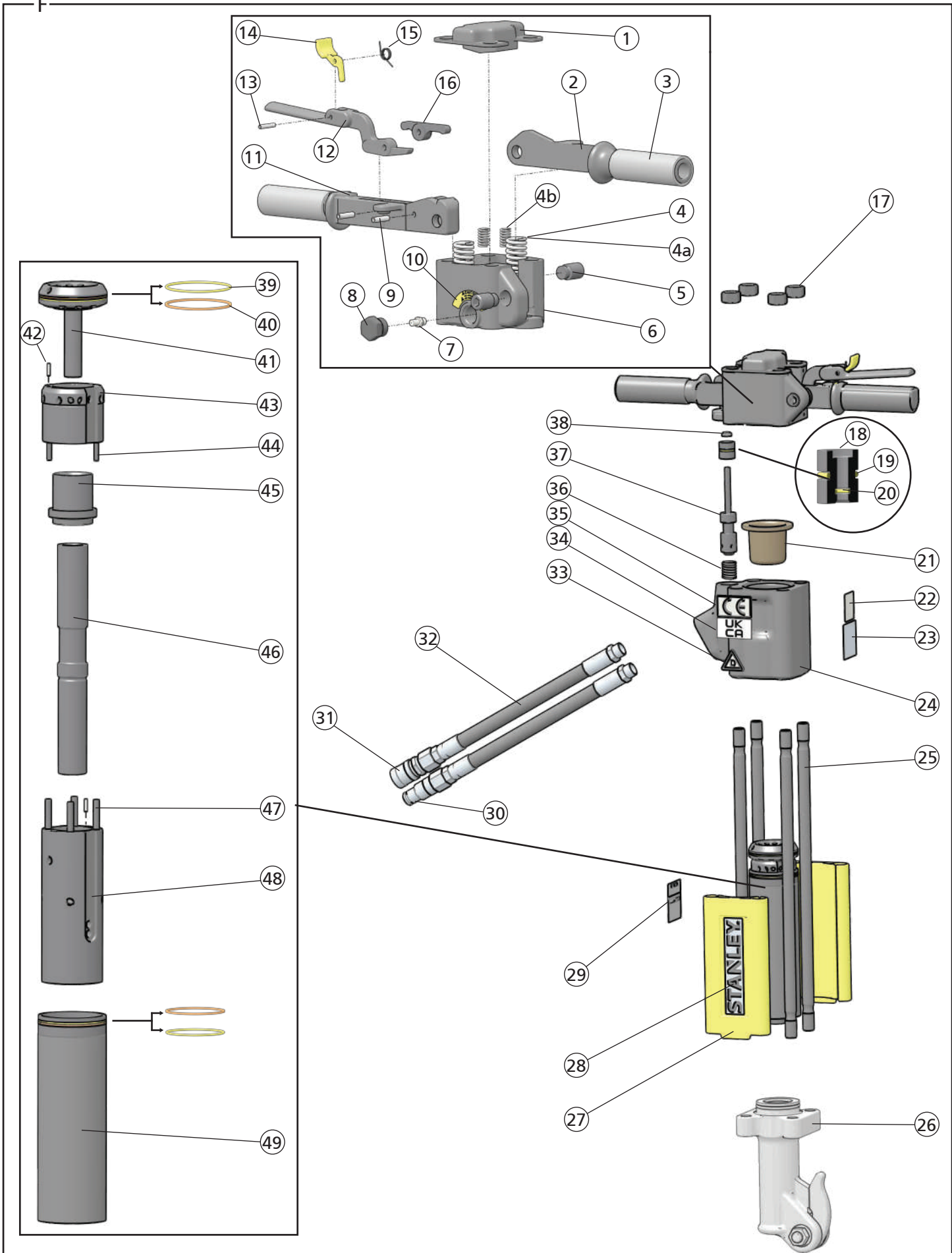

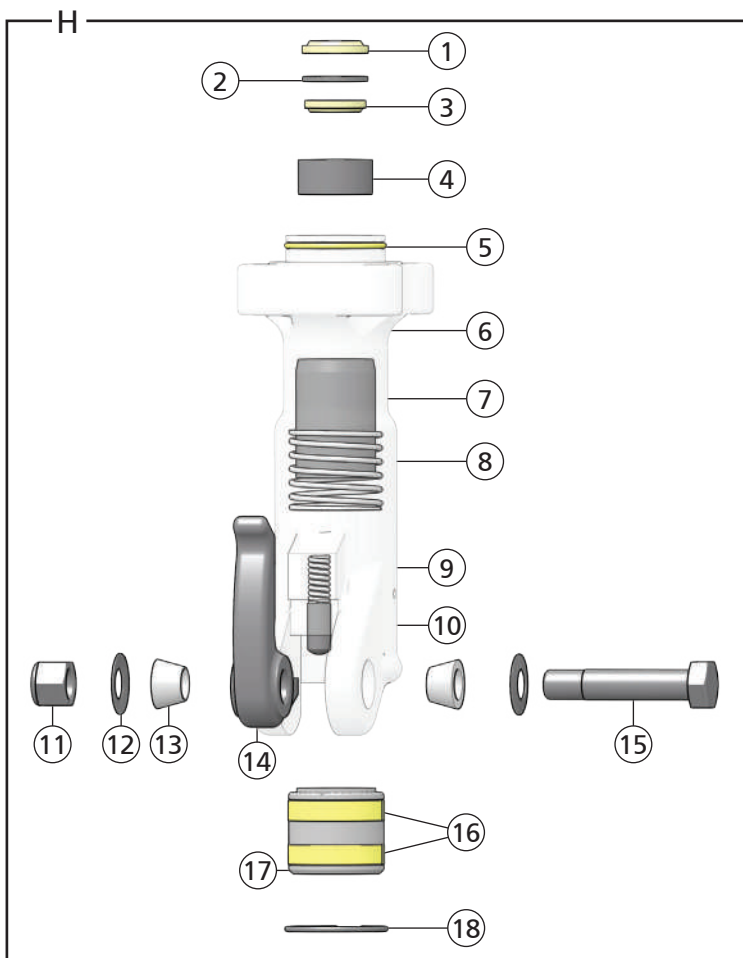
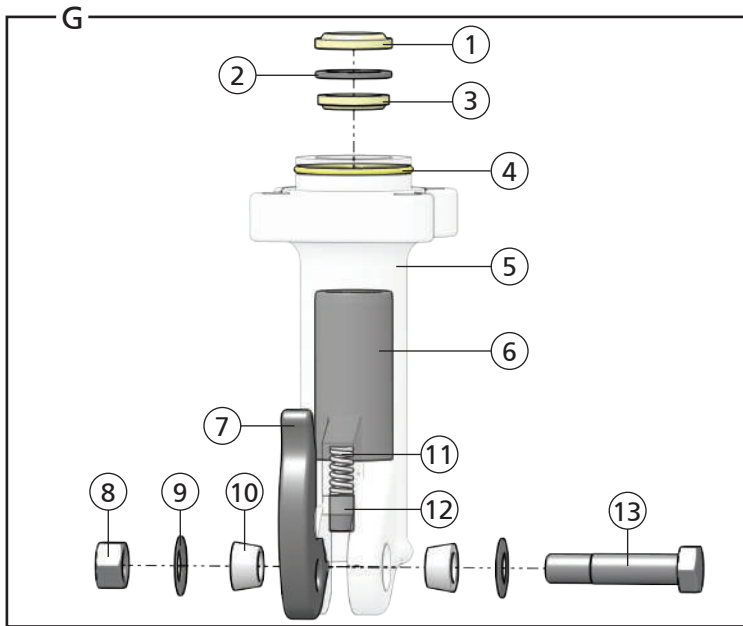

T-Handle Parts Illustration - Detail E		
ITEM	P/N	DESCRIPTION
1	04374	Hex Nut
2	04371	Trigger
3	07493	O-ring Plug
4	20499	Charge Valve
5	07492	Roll Pin
6	02494	Handle Grip
7	07483	Handle
8	04056	Rod Wiper*
9	04057	Bushing
10	00293	O-ring*
11	01362	O-ring*
12	04077	Valve Spool
13	04058	Compression Spring
14	11588	Accumulator Valve Block
15	01652	Hose Whip, 12 in.
16	03972	Coupler, Female
17	03973	Coupler, Male
18	74664	Name Tag (8 GPM models)
	74660	Name Tag (5 GPM models)
	74669	Name Tag (Underwater models)
19	04373	Side Rod
20	Depends on model	Breaker Foot, see detail G & H.
21	72919	Snap-On Filler
22	74832	STANLEY Logo Sticker (Black)
	74770	STANLEY Logo Sticker (Yellow)
23	07479	Accumulator Diaphragm
24	04381	Back-up Ring*
25	04379	O-ring*
26	04378	Porting Block
27	02900	Roll Pin
28	07480	Automatic Valve Body
29	04571	Push Pin
30	04382	Automatic Valve
31	07481	Piston
	12833	Piston (BR45550 Only)
32	04605	Push Pin
33	07485	Flow Sleeve
34	04383	Flow Sleeve Tube
35	04595	Seal Kit (*In seal kit)





Anti-Vibration Parts Illustration - Detail F		
ITEM	P/N	DESCRIPTION
1	28494	Top Plate
2	28369	Guarded Handle
3	02494	Handle Grip
4	20498	Spring
4a	20540	Springs - Models BR45125S, BR45135S, BR4513516, BR45158, BR45158BN
4b	20541	
5	20508	Pivot Screw

Anti-Vibration Parts Illustration - Detail F		
ITEM	P/N	DESCRIPTION
6	20505	Handle Pivot Block
7	20499	Charge Valve
8	07493	Plug
9	20500	Roll Pin
10	10180	Caution N2 Gas Sticker
11	58529	Trigger Handle
12	58526	Trigger
13	07624	Roll Pin
14	58527	Trigger Lock
15	66828	Torsion Spring
16	20511	Lever
17	04374	Hex Nut
18	07699	Bushing Assembly
19	00293	O-ring*
20	01362	O-ring*
21	07479	Accumulator Diaphragm
22	58601	Sound Power Level Sticker
23	28409	Composite Sticker
24	11588	Accumulator Valve Block
25	20517	Side Rod
26	Depends on model	Breaker Foot, see detail G & H.
27	72919	Snap-On Filler
28	74832	STANLEY Logo Sticker (Black)
	74770	STANLEY Logo Sticker (Yellow)
29	74663	Name Tag (8 GPM Models)
	74659	Name Tag (5 GPM Models)
30	03973	Coupler, Male
31	03972	Coupler, Female
32	01652	Hose Whip, 12 in.
	56725	Hose Whip, 18 in. (Model BR45158)
	66727	Hose Whip (Model BR45158BN)
33	11207	Circuit Type "D" Sticker
34	88724	UKCA Sticker
35	28322	CE Sticker
36	04058	Compression Coil Spring
37	20515	Valve Spool
38	04056	Rod Wiper*
39	04381	Back-up Ring*
40	04379	O-ring*
41	04378	Porting Block
42	02900	Roll Pin
43	07480	Automatic Valve Body
44	04571	Push Pin
45	04382	Automatic Valve
46	07481	Piston
	12833	Piston (Model BR4556801)
47	04605	Push Pin
48	07485	Flow Sleeve
49	04383	Flow Sleeve Tube

Breaker Foot Assembly - Detail G							
ITEM	DESCRIPTION	QTY	MODEL				
			BR4516801, BR4516807, BR4516807A, BR4556801	BR45150, BR45158, BR45158BN, BR45550	BR45350	BR4514801	BR45110
1	Cup Seal	1	04386				
2	Back-up Washer	1	04780				
3	Rod Wiper	1	04387				
4	O-ring	1	02022				
5	Breaker Foot	1	07510	07489	08856	07694	07899
6	Hex Bushing	1	07510	07489	08856	07694	07899
7	Latch	1	04394				
8	Hex Nut	1	04374				
9	Spring Washer	2	04716				
10	Taper Sleeve	2	04715				
11	Spring	1	04392				
12	Detent	1	04393				
13	Latch Bolt	1	04717				

Breaker Foot Assembly - Detail H						
ITEM	DESCRIPTION	QTY	MODEL			
			BR45120, BR45120D	BR45130	BR45130E, BR45130EL, BR45135S	BR45120E, BR45125S
1	Cup Seal	1	04386			
2	Back-up Washer	1	04780			
3	Rod Wiper	1	04387			
4	Insert	1	62334	72931	08081	08154
5	O-ring	1	02022			
6	Breaker Foot	1	62334	72931	08081	08154
7	Hex Bushing	1	62334	72931	08081	08154
8	Compression Coil	1	---		81197	
9	Spring	2	01744			
10	Detent	1	08411			
11	Hex Nut	1	04984			
12	Spring Washer	2	04985			
13	Taper Sleeve	2	01269			
14	Latch	1	01837			
15	Latch Bolt	1	04983			
16	Wear Ring	2	---		07516	
17	Collar Support	1	---		08116	08115
18	Retaining Ring	1	---		07522	

## Safety Precautions

	The Safety Alert Symbol alerts you to potential personal injury hazards. Obey all safety messages that follow to avoid possible injury or death.
	Indicates an imminently hazardous situation which will result in death or serious injury.
	Indicates a potentially hazardous situation which could result in death or serious injury
	Indicates a potentially hazardous situation which could result in property damage.

Always observe safety symbols. They are included for your safety and for the protection of the tool.



**WARNING:** Read all safety warnings and instructions. Failure to follow the warnings and instructions may result in tool damage and/or serious injury.

**WARNING:** To reduce the risk of injury, read the instruction manual.

## General

- Do not discard safety instructions. Give to the operator.
- This tool will provide dependable service if operated in accordance with the instructions given in this manual. Read and understand this manual and any stickers and tags attached to the tool and hoses before operation. Failure to do so could result in personal injury or equipment damage.
- Inspect the tool before each use and ensure all decals are legible. Contact STANLEY if replacements are needed.
- Establish a training program for all operators to ensure safe operation. Do not operate the tool unless thoroughly trained or under the supervision of an instructor. Keep out of the reach of children.
- Operators and maintenance personnel shall be able to physically handle the bulk, weight and power of the tool.
- Avoid unsuitable postures as these positions do not allow for counteracting of normal or unexpected movement of the tool, such as a sudden break of the tool bit. Change postures during extended tasks to help avoid discomfort or fatigue.
- Never use the tool unless the inserted tool is retained with a proper retainer.
- Do not operate a damaged, improperly adjusted, modified or incompletely assembled tool.
- Use and maintain the tool as stated in this manual. Misuse of the tool can cause serious injury. Do not modify the tool in any way.
- Do not operate the tool in explosive atmospheres, such as in the presence of flammable liquids, gases or dust. Power tools create sparks which may ignite the dust or fumes.
- Provide adequate ventilation in closed areas when operating a gas or diesel hydraulic power source.
- Do not inspect, carry, clean, change accessories or perform maintenance on the tool while the power source is connected. Accidental engagement of the tool can cause serious injury.
- Ensure work piece is securely fixed. Be aware that failure of the work piece or accessories may generate high velocity projectiles.
- Never use the tool bit as a hand struck tool.
- Stay alert, watch what you are doing and use common sense when operating a hydraulic tool. Do not operate this tool if you are tired or under the influence of drugs or alcohol. A moment of inattention while operating hydraulic tools may result in serious injury.
- During operation, do not contact mechanisms, accessories or hardware as they can become very hot or sharp; use your Personal Protection Equipment (PPE).
- Supervising personnel should develop additional precautions relating to the specific work area and local safety regulations.
- Never operate the tool if you are unsure about the presence of underground utilities, such as electrical cables, gas pipes, etc. These can cause a hazard if damaged with the tool.
- The tool is not insulated against coming into contact with electric power. Use hose certified as non-conductive.
- Do not overreach. Maintain proper footing and balance at all times when using the tool.

- Slips, trips and falls are major causes of workplace injury. Be observant of hoses or oil surfaces lying about the work area, as they can be a tripping hazard.
- Operators must start in a work area without bystanders and must assess the risks to bystanders.
- Keep work area clean and well lit. Cluttered or dark areas invite accidents.
- Operators must be familiar with all prohibited work areas such as excessive slopes and dangerous terrain conditions.
- Only use clean hydraulic fluid, filling equipment and lubricants that have been recommended by STANLEY.
- Ensure tools are working properly and safely by performing preventative maintenance (PM) procedures.
- Repair and service of this tool must only be performed by an authorized and certified dealer.
- Do not force the tool to do the work of a larger tool. Use the correct tool for your application.
- Use only hoses and hose couplings that are rated for a minimum working pressure of 2500 PSI (172 BAR).
- In spite of the application of relevant safety regulations and the implementation of safety devices, certain residual risks cannot be avoided. These risks are: repetitive strain injury due to incorrect posture and risk of pinching fingers when changing tool bit.

## Dust and Fumes

- **WARNING:** Some dust created by power sanding, sawing, grinding, drilling, and other construction activities contains chemicals known to the State of California to cause cancer, birth defects or other reproductive harm. Some examples of these chemicals are:
  - Lead from lead-based paints,
  - crystalline silica from bricks and cement and other masonry products, and
  - arsenic and chromium from chemically-treated lumber.

Your risk from these exposures varies, depending on how often you do this type of work. To reduce your exposure to these chemicals: work in a well ventilated area, and work with approved safety equipment, such as those dust masks that are specially designed to filter out microscopic particles. Protect yourself and those around you. Research and understand the materials you are grinding. Follow correct safety procedures and comply with all applicable national, state or provisional health and safety regulations relating to them, including, if appropriate arranging for the safe disposal of the materials by a qualified person.

- When dust or fumes are created, control them at the point of emission. Direct tool exhaust to minimize disturbance of dust.
- Operate and maintain the tool as recommended in this manual to minimize dust.
- Use respiratory protection in accordance with employers instruction or as required by occupational health and safety regulations.
- Avoid prolonged contact with dust. Allowing dust to get into your mouth, eyes or lay on the skin may promote absorption of harmful chemicals.

## PPE

- Always wear safety equipment such as impact resistant goggles, ear protection, head protection, breathing protection and safety shoes at all times when operating the tool.
- Hands may be exposed to hazards, impacts, cuts, abrasions and heat. Wear gloves.
- Wear a hardhat if performing overhead work.
- Use PPE that conforms to standards ANSI Z87.1 (Eye and Face Protection), ANSI Z89.1 (Head Protection), ANSI Z41.1 (Foot Protection) and ANSI S12.6 (S3.19) (Hearing Protection).
- Do not wear loose fitting clothing or jewelry when operating the tool.



M003  
Wear Ear  
Protection



M004  
Wear Eye  
Protection



M016  
Wear a Mask

## Sound

- Exposure to high noise levels can cause permanent, disabling hearing

loss and other problems, such as tinnitus (ringing, buzzing, whistling or humming in the ears). Use hearing protection in accordance with employer's instructions and as required by occupational health and safety regulations.

- Use and maintain as recommended in the manual to prevent an unnecessary increase in noise levels.

## Vibration

- When using a non-rotary percussive tool to perform work related activities, the operator can experience discomfort in the hands, arms, shoulders, neck or other parts of the body.
- If you experience numbness, tingling, pain or whitening of the skin in your fingers or hands, stop using the tool. Tell your employer and consult a physician.
- Wear warm clothing when working in cold conditions and keep your hands warm and dry.
- Exposure to vibration can cause disabling damage to the nerves and blood supply of the hands and arms.
- Use and maintain as recommended in the manual to prevent an unnecessary increase in vibration.
- Check for vibration level before each service. If you feel a higher than normal vibration, contact your STANLEY dealer for repair.

## Hydraulic

- **Warning:** Hydraulic fluid under pressure could cause skin injection injury. Do not check for leaks with your hands. If you are injured by hydraulic fluid, get medical attention immediately.
- Do not let hydraulic oil get on the skin. Hydraulic oil is hot. Wear Personal Protection Equipment (PPE) at all times.
- If exposed to hydraulic fluid, wash hands immediately.
- Do not exceed the maximum relief valve setting stated on the tool.
- Inspect and clean couplers before use, daily. Replace damaged couplers immediately.
- Hydraulic circuit control valve must be OFF before coupling or uncoupling tools. Failure to do so may damage the couplers and cause overheating of the hydraulic system.
- Ensure the couplers are properly connected and are tight.
- Do not operate the tool at fluid temperatures above 140°F (60°C). Higher temperatures can cause operator discomfort and damage to the tool.
- Do not exceed the rated flow and pressure as stated on the tool. Rapid failure of the internal seals may result.

## What is the BR45 Hydraulic Breaker?

BR45 is a hydraulic breaker for use in the 35-55 lbs. weight class. Designed for light to medium duty operation, BR45 excels at curb and sidewalk demolition, asphalt cutting and ground rod driving. BR45 requires an external hydraulic power source capable of supplying 7-9 GPM or 4-6 GPM, depending on model.

Specifications		
Pressure	1500-2500 PSI (103-172 BAR)	
Flow	7-9 GPM (26-34 LPM) OR 4-6 GPM (15-22 LPM)	
Max. Pressure	2500 PSI (172 BAR)	
Max. Relief Pressure	2150 PSI (148 BAR)	
Recommended Back Pressure	250 PSI (17 BAR) or less	
Couplers	3/8 inch male pipe hose ends, HTMA flush face	
Port Size	SAE 8 O-ring	
Tool Weight	T-Handle: 51 Lbs (23 Kg) Anti-vibration: 55 Lbs (25 Kg)	
Tool Length	T-Handle: 27 inches (69 cm) Anti-vibration: 29 inches (74 cm)	
Width (at handles)	T-Handle: 14 inches (36 cm) Anti-vibration: 18 inches (46 cm)	
Max. Hydraulic Oil Temp.	140°F (60°C)	
HTMA/EHTMA Category	Type 2, Category D	
Underwater Tool Max. Depth	500 Ft. (Increase accumulator charge by 40 PSI per 100 Ft.)	
Recommended Hose Diameters for Underwater Applications		
Depth	8 GPM (30 LPM)	12 GPM (45 LPM)
100 Feet (31 Meters)	5/8 Inches (16 mm)	5/8 Inches (16 mm)
300 Feet (91 Meters)	3/4 Inches (19 mm)	1 Inch (25.4 mm)
600 Feet (183 Meters)	1 Inch (25.4 mm)	1 Inch (25.4 mm)
1000 Feet (305 Meters)	1 Inch (25.4 mm)	1 1/4 Inches (32 mm)

Sound & Vibration Declaration	
BR45 Anti-vibration Handle	
Measured A-Weighted sound power level	105 dBA
Uncertainty	1.7 dBA
Measured A-Weighted Sound Pressure	98 dBA
Uncertainty	3 dBA
Values determined according to noise test code given in ISO 15744, using the basic standard ISO3744. Test conducted by independent notified body to comply with 2000/14/EC:2005.	
Measured Vibration Emission Value: 3-Axis	18.9 m/sec <sup>2</sup>
Uncertainty	2.38 m/sec <sup>2</sup>
BR45 T-Handle	
Measured Vibration Emission Value: 3-Axis	19.1 m/sec <sup>2</sup>
Uncertainty	2.38 m/sec <sup>2</sup>

## Parts of a BR45 - Detail A

1	Handle
2	Gas Under Pressure Decal
3	Accumulator Charging Port

4	STANLEY Logo Decal
5	Composite Safety Decal (CE Models)
6	Sound Power Level Decal (CE Models)
7	Trigger Lock
8	Trigger
9	CE Decal (CE Models)
10	UKCA Decal
11	Circuit Type "D" Decal (CE Models)
12	Tool Bit Latch
13	Breaker Foot
14	Tool Name Tag
15	Hydraulic Input and Output Ports

## Tool Setup - Detail B

- Using a calibrated flow and pressure gauge, check the output of the hydraulic power source. Ensure it matches the flow and pressure in "Specifications" on page 11. Hydraulic fluid must be 50°F or above. Preheat if necessary.
- Ensure that the hydraulic power source is equipped with a relief valve set to open at the maximum relief pressure. See "Specifications" on page 11.

### **WARNING**

Do not install or change tool accessories while the hydraulic power source is connected. Accidental engagement of the tool can cause serious injury. Disconnect the hydraulic power source before installing or changing accessories.

- Power down the hydraulic power source. Disconnect from the tool.
- Unlock the breaker foot latch.
- Insert the tool bit and lock the latch. Never use BR45 unless the tool bit is locked in the retainer.
- Note: Never use a blunt tool bit as they cause more vibration.
- Wipe the hydraulic couplers clean. Connect to the hydraulic power source.
- Power up the hydraulic power source.

## Tool Operation - Detail C

### **CAUTION**

Always hold tool with both hands to maximize control. Apply proper down pressure and maintain proper footing at all times.

- Wrap your hands around the handles. Stand in back of the tool, using your leg against the snap-on filler for stability.
- Note: Hold the tool correctly and be ready to counteract normal or sudden movements. Have both hands available.
- Place the breaker bit on the material to be broken, at a 90° angle. Apply down pressure.
- Flip the trigger lock (CE models only).
- Slowly squeeze the trigger to start breaking. Squeeze harder for fast speed operation.
- When starting, break until the tool bit breaks through, then reposition the bit. Do not use the tool bit as a lever to move material.
- Note: Never cool a hot tool bit in water. Tools can become brittle and can fail.
- Continue breaking around the original hole, in 2 inch sized bites.
- Release Trigger to stop the tool.
- Note: If you encounter a breakdown or the tool stops for any reason, release the trigger and power down the hydraulic power source.

## Tool Maintenance

Use only accessories, consumables and parts recommended by STANLEY.

### Daily Maintenance

1. Remove hydraulic power from the tool and check all hydraulic connections and hoses for damage. Replace damaged parts before operating the tool.
2. Inspect the tool bit latch and associated parts. Replace when they have become worn, cracked or distorted.
3. Inspect tool to ensure all stickers are legible. Contact STANLEY if replacements are needed.
4. Check the flow and pressure of the hydraulic power source using a calibrated flow meter. Proper flow and pressure maintain proper tool speed. If tool speed increases or decreases, stop using the tool and ensure proper flow and pressure.

### Accumulator Charge - Detail D

Check accumulator charge every 6 months or if poor performance develops.

### Required Tools:

- STANLEY Accumulator Charge Kit (P/N 31254)
- Nitrogen Bottle

### Check

1. Remove the charging plug from the breaker handle.
2. (a) Hold the chuck end of the tester and (b) twist the gauge counter-clockwise. This will retract the valve stem.
3. Screw the tester onto the breaker charging port.
4. Twist the tester gauge clockwise and read the pressure indicated on the gauge. Charge should be 500-700 PSI (34-48 BAR).

### Charge

5. Retract the tester valve stem.
6. Connect the charging assembly hose to the tester.
7. Twist the tester gauge clockwise to advance the valve stem.
8. Slowly open the snub valve and charge to 600 PSI (42 BAR).
9. Close the snub valve, retract the tester valve stem and remove the tester from the breaker charging port. Replace the charging plug.

### Underwater Tool Maintenance

1. Using a water displacing oil, spray into the trigger slot.
2. Spray into the side holes.
3. Spray into the breaker foot and remove water from the breaker foot.
4. Spray or dip the rest of the tool.

### Tool Storage

Clean the tool and store in a clean, dry space that is safe from damage. Ensure the tool is secured and will not move during transport. An unsecured tool could cause injury or damage to the tool.

### Tool Disposal

#### Hydraulic Oil

Hydraulic oil can contaminate the air, ground and water if not properly recycled. Recycle hydraulic oil in accordance with all State, Federal and local laws, at your local oil recycling facility.

#### Hydraulic Hoses

Hang hydraulic hoses to drain. Collect the oil for recycling. Contact your local municipal recycling authorities for an approved hydraulic hose recycling site.

#### Tool Body

Drain hydraulic oil from the tool, making sure to collect the oil for recycling. Discharge the accumulator, disassemble the tool and dispose of all non-metal parts. Recycle the metal components. Contact your local municipal recycling authorities for recycling instructions.

Accessories			
7/8 inch hex x 3 1/4 inch shank			
16 in. Clay Spade	02328	14 in. Chisel, 3 in wide	02330
5 in. Asphalt Cutter, 5 in wide	02341	18 in. Moil Point	04401
14 in. Moil Point	05255	.75 in. Rod Driver	05255
1 inch hex x 4 1/4 inch shank			

Accessories			
14 in. Moil Point	07702	14 in. Narrow Chisel Point	07703
14 in. Chisel, 3 in. wide	07704	5.25 in Clay Spade	07705
Asphalt Wedge, 3 in wide	07706	1 in. Lag Bolt Driver	208001
1 in. Lag Bolt Driver	73355	Spike Driver Bit	38709
5 in. Tie Tamper	29431		
1 1/8 inch hex x 6 inch shank			
14 in. Moil Point	02333	14 in. Chisel Point	03990
14 in. Chisel, 3 in. wide	02334	5 1/2 in. Clay Spade	02331
12 in. Asphalt Wedge	08106	5 in. Asphalt Cutter	02332
1 in. Ground Rod Driver	04176		
1 1/4 inch hex x 6 inch shank			
14 in. Moil Point	02336	14 in. Chisel, 3 in. wide	02337
5 1/2 in. Clay Spade	09262	Asphalt Cutter, 5 inch wide	02335
1 in. Ground Rod Driver	04367	1 in. Heavy Duty Chisel	02338
18 in. Heavy Duty Moil Point	04404	8 in. Clay Spade	04405
Detachable Shank for 17783	17782	Tamping Pad for 17782	17783

### Troubleshooting

Problem	Possible Cause	Solution
Tool does not run or runs improperly.	The hydraulic power source is not running or not running properly.	Ensure the power source is delivering proper flow and pressure. See "Specifications" on page 11. Proper flow and pressure maintain proper tool speed. Check regularly.
	Couplers or hoses are blocked.	Turn off and disconnect the tool from the hydraulic power source. Inspect and ensure no blockage exists.
	Low accumulator charge.	Check and recharge accumulator if necessary. See "Accumulator Charge - Detail D" on page 12.
	Hydraulic fluid is too hot.	Provide a cooler to maintain proper temperature. See "Specifications" on page 11.
	High back pressure.	Check the hydraulic system for excessive back pressure.
	Mechanical failure of piston or automatic valve.	Contact your STANLEY dealer for service.
Fluid leakage on tool bit.	Lower piston seal failure.	Contact your STANLEY dealer for service.
Fluid leakage around the tool trigger.	Valve spool failure.	Contact your STANLEY dealer for service.







**STANLEY®**

STANLEY

3810 SE Naef Road, Milwaukie, OR 97267 United States of America  
(503) 659-5660 / Fax (503) 652-1780

© STANLEY

3810 SE Naef Road, Milwaukie, OR 97267 USA