

V Series Needle Valve V4C Series Needle Valve



MAXIMUM WORKING PRESSURE AND TEMPERATURE

BRASS, STEEL, AND ALLOY 400 NEEDLE VALVES

Stem Packing	Stem Type	Maximum Pressure & Temperature	Maximum Temperature & Pressure
PTFE: V2	Metal-to-Metal	3000 psig @ 70 °F (20.7 MPa @ 21 °C)	0 psig @ 450 °F* (0 MPa @ 232 °C)
	PCTFE	3000 psig @ 70 °F (20.7 MPa @ 21 °C)	0 psig @ 350 °F (0 MPa @ 177 °C)
V4, V6, V8, V12	Metal-to-Metal	3000 psig @ 70 °F (20.7 MPa @ 21 °C)	0 psig @ 450 °F* (0 MPa @ 232 °C)
	PCTFE	3000 psig @ 70 °F (20.7 MPa @ 21 °C)	0 psig @ 350 °F (0 MPa @ 177 °C)
O-Ring: V2, V4, V6, V8, V12	Metal-to-Metal	3000 psig @ 70 °F (20.7 MPa @ 21 °C)	0 psig @ 400 °F* (0 MPa @ 204 °C)
	PCTFE	3000 psig @ 70 °F (20.7 MPa @ 21 °C)	0 psig @ 350 °F (0 MPa @ 177 °C)

*Note: Maximum temperature for steel is 350 °F (177 °C)

Always consult your authorized Parker representative if questions arise. The arrow on the Valve Body indicates the normal direction of flow.

MAXIMUM WORKING PRESSURE AND TEMPERATURE

STAINLESS STEEL NEEDLE VALVES

Stem Packing	Stem Type	Maximum Pressure & Temperature	Maximum Temperature & Pressure
PTFE: V2	Metal-to-Metal	5000 psig @ 70 °F (34.5 MPa @ 21 °C)	0 psig @ 450 °F (0 MPa @ 232 °C)
	PCTFE	5000 psig @ 70 °F (34.5 MPa @ 21 °C)	0 psig @ 350 °F (0 MPa @ 177 °C)
V4, V6, V8, V12	Metal-to-Metal	5000 psig @ 70 °F (34.5 MPa @ 21 °C)	0 psig @ 450 °F (0 MPa @ 232 °C)
	PCTFE	5000 psig @ 70 °F (34.5 MPa @ 21 °C)	0 psig @ 350 °F (0 MPa @ 177 °C)
O-Ring: V2, V4, V6, V8, V12	Metal-to-Metal	5000 psig @ 70 °F (34.5 MPa @ 21 °C)	0 psig @ 400 °F (0 MPa @ 204 °C)
	PCTFE	5000 psig @ 70 °F (34.5 MPa @ 21 °C)	0 psig @ 350 °F (0 MPa @ 177 °C)

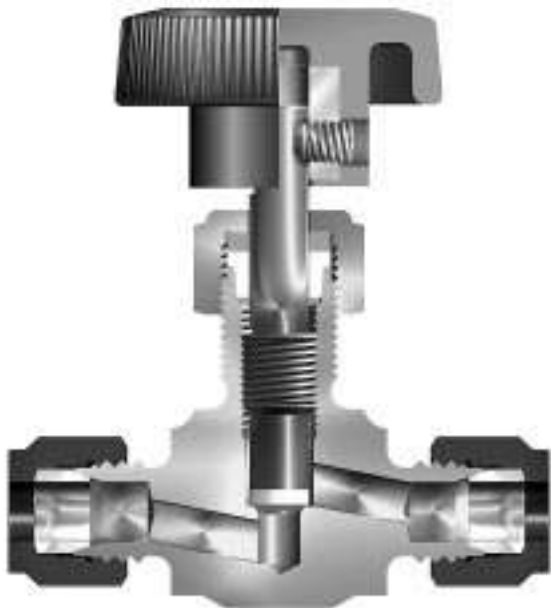

Figure 1: V Series Needle Valve Cross Sectional View (Sizes V4 to V12)



Figure 2: V4C Series Needle Valve Cross Sectional View

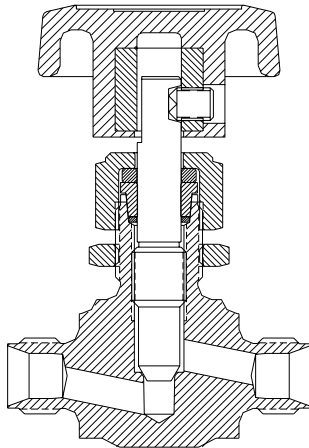

Figure 3:
**Cross Sectional View of Needle Valve
with Tapered Packing**

Note: The tapered PTFE packing is used in V4 thru V12 and V4C Needle Valves.

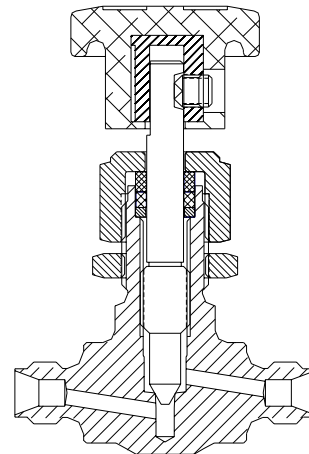

Figure 4:
**Cross Sectional View of Needle Valve
with Parallel PTFE Packing**

Note: The cylindrical PTFE packing is used in the V2 Needle Valve.

DISASSEMBLY

WARNING: MAKE CERTAIN THE SYSTEM IN WHICH THE VALVE IS INSTALLED IS DRAINED AND/OR EXHAUSTED OF ALL PRESSURE BEFORE STARTING VALVE REMOVAL OR DISASSEMBLY. FAILURE TO DO SO CAN CAUSE DEATH, PERSONAL INJURY AND PROPERTY DAMAGE.

1. Verify that the Needle Valve Maintenance Kit being used is appropriate for the Valve's size, Handle, Stem Seat material, Stem Packing configuration, and service requirements. Always contact your authorized Parker representative if any questions arise.
2. Remove the Handle by turning the Set Screw counter-clockwise with a 5/64 inch allen wrench for the size 2 Needle Valve or a 3/32 inch allen wrench for all other Needle Valves.
3. Remove the Packing Nut, located directly under the Handle, by turning counter-clockwise with the following size hex wrench:

V2	9/16 inch
V4/V4C	5/8 inch
V6	3/4 inch
V8	7/8 inch
V12	7/8 inch

4. Gently remove the Stem assembly from the Body by turning counterclockwise
5. If applicable, remove the Body from its panel mounting hole by turning the Panel Nut counter-clockwise.
6. Discard the old Stem, and either the PTFE Packing or the O-Ring, as applicable for the valve model being serviced.

REASSEMBLY

1. Make certain all parts are free of dirt or other contamination before starting reassembly of the Valve.
2. Secure the Body in an assembly fixture.
3. For Valves with the "K" (soft-seat) option, verify the Soft Seat is securely attached to the Stem.
4. This step assembles the variety of stem packing options. Refer to the specific packing type being assembled. In each instance, stack the packing components on the stem in the order listed with the first item being placed on the landing above the stem threads.

PTFE Stem Packing (standard for V4, V4C, V6, V8 & V12):

1. Lower Packing Washer
2. PTFE Stem Packing
3. Upper Packing Washer

PTFE Stem Packing (standard for V2):

1. Packing Washer
2. PTFE Stem Packing
3. Packing Gland

O-Ring Stem Packing (optional for V4, V4C, V6, V8 & V12):

Apply a small amount of lubricant, as consistent with the valve's service requirements, to the O-ring.

1. Lower Packing Washer
2. O-Ring (lubricated)
3. O-Ring Back-up Ring
4. O-Ring Packing Gland

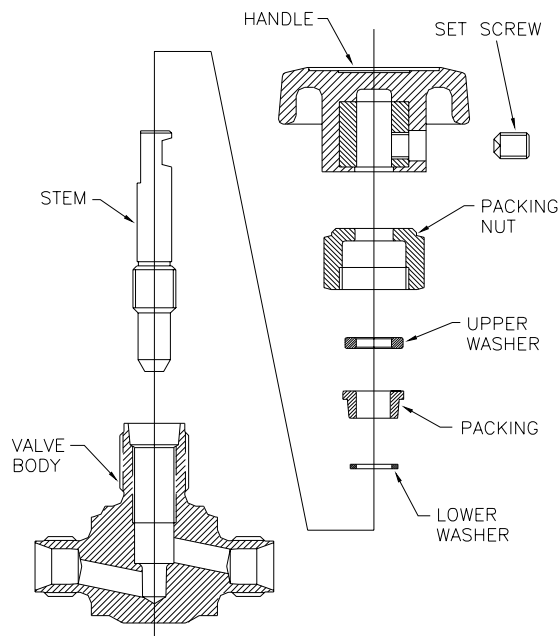

Figure 5:
**Exploded View of Needle Valve
with Tapered Packing**

Note: The tapered PTFE packing is used in V4 thru V12 and V4C Needle Valves.

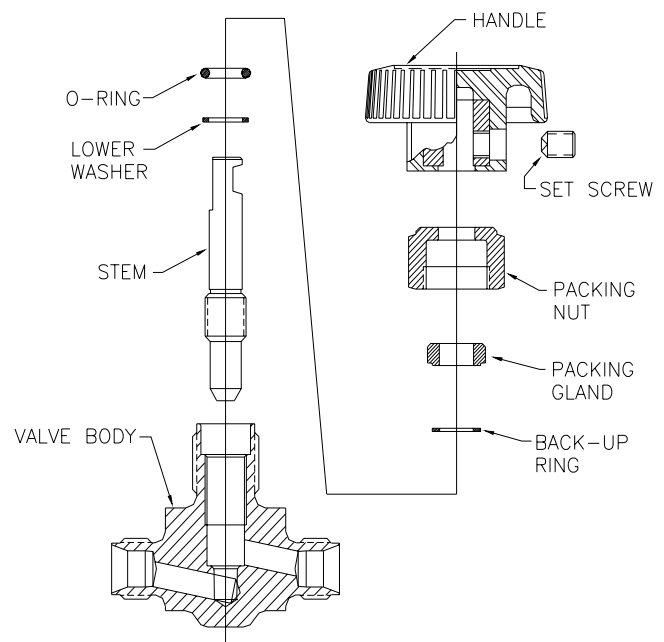
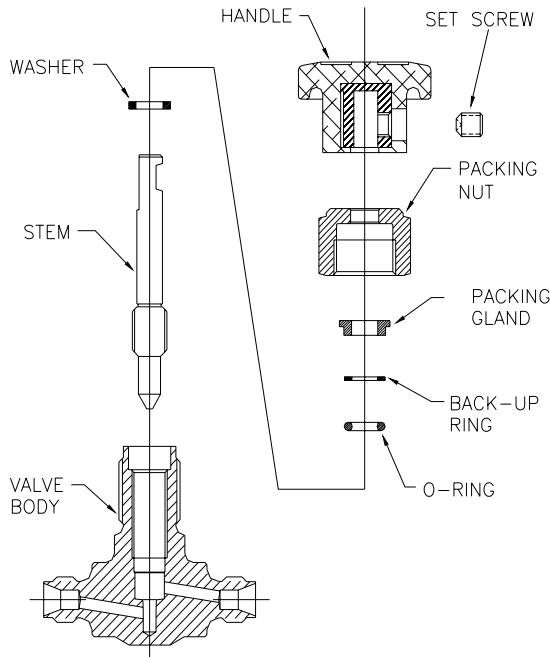

Figure 6:
**Exploded View of Needle Valve
with O-Ring Packing**

Note: This style of O-ring Packing is used in V4 thru V12 and V4C Needle Valves.



**Figure 7:
Exploded View of Needle Valve
with O-Ring Packing**

Note: This style of O-ring Packing is used the V2 Needle Valve.

Apply a small amount of lubricant, as consistent with the valve’s service requirements, to the O-ring.

1. Packing washer
2. O-Ring (lubricated)
3. O-Ring Packing Gland

5. Apply a liberal amount of lubricant, as consistent with the Valve’s service requirements, to the Stem threads.

Note: Every Power Thread must be covered with lubricant.

6. For valves with an “N” or “R” stem option. Apply a small drop of lubricant, as consistent with the valve’s service requirements, to the Stem cone area.
7. Insert the Stem Assembly into the Body until it is finger-tight.
8. If applicable, insert the Valve Body into its panel mounting hole and thread the Panel Nut unto the Valve Body until its secure to the panel.
9. Apply a liberal amount of lubricant, as consistent with the Valve’s service requirements, to the Packing Nut threads.
10. Install the Packing Nut onto the Valve Body until finger-tight.
11. For valves with the “K” (soft seat) stem option, complete the following instructions. Valves with other stem options proceed to step 12.
 - a) Turn the valve to the OPEN position
 - b) Torque the Packing Nut as specified in Table I.
 - c) Turn the stem to the CLOSED position and torque to 5 in-lbs.
 - d) Proceed to step 14.
12. Turn the “N” or “R” stem to the CLOSED position and torque to 8 in-lbs.
Torque the Packing Nut to the Valve Body as specified in Table I.
14. Install the proper Handle on to the Stem. Secure the handle with the Handle Set Screw and tighten to 15 in-lbs.

NOTE: The Bar Handle option must not be used on Valves with the “K” stem/ option.

15. Turn the Valve Handle through at least one (1) open/close cycle to verify proper operation of the Stem’s threads.

**Table I
Packing Nut Installation Requirements**

Valve Size	Hex Wrench Size	Torque Requirement
V2	9/16 inch	30 In-lbs. (3.4 N-m)
V4/V4C	5/8 inch	40 In-lbs. (4.5 N-m)
V6	3/4 inch	65 In-lbs. (7.3 N-m)
V8	7/8 inch	90 In-lbs. (10.2 N-m)
V12	7/8 inch	90 In-lbs. (10.2 N-m)

VALVE CONNECTOR MAKE-UP INSTRUCTIONS

MALE AND FEMALE PIPE PORTS

Wrench flats are provided on the Valve Body. It is recommended a smooth-jawed wrench or vise be used to grip the Valve Body.

1. On the male threaded part of the connection, apply a high quality pipe joint compound or PTFE tape made for this purpose. When PTFE tape is used, it is recommended two full turns of tape be applied. PTFE tape should not be overhanging or covering the first thread
2. Engage the Valve and the other component part together, until hand-tight.
3. With a proper wrench, holding both the Valve and the component part, continue to tighten to achieve a leak-tight joint.

ULTRASEAL CONNECTIONS

1. Insert the proper O-Ring into the UltraSeal fitting's O-Ring groove. Position the UltraSeal gland sealing face against the O-Ring, and then advance the Nut to a finger-tight position.
2. A positive seal is obtained by advancing the Nut no less than 1/4 turn from the finger-tight position. Proper UltraSeal make-up is achieved when a sharp rise in required application torque occurs, which indicates proper seal face contact and O-Ring seal compression into the UltraSeal groove.

VACUSEAL CONNECTIONS

1. A positive seal is obtained by advancing the Nut 1/8 turn from the finger-tight position.
2. A new gasket should be installed upon each fitting re-make to insure system pressure integrity.

TUBE FITTING CONNECTIONS

1. Insert the tube into the Valve port until the tube bottoms out in the Valve Body. Care should be exercised to insure the tube is properly aligned with the Valve Body and port.
2. Normal make-up for US Customary port sizes 1 thru 3 (1/16 thru 3/16 inch) and SI port sizes 2 thru 4 (2 thru 4 mm) is 3/4 turn from finger tight. Normal make-up for US Customary port sizes 4 thru 16 (1/4 thru 1 inch) and SI port sizes 5 thru 25 (5 thru 25 mm) is 1 1/4 turn from finger tight. For larger port sizes consult Parker Ferrule Presetting Tool Instructions.

PLEASE FOLLOW THE ABOVE DIRECTIONS FOR COUNTING THE NUMBER OF TURNS FOR PROPER FITTING MAKE-UP. DO NOT MAKE-UP TUBE FITTINGS BY TORQUE OR "FEEL". VARIABLES SUCH AS TUBING AND FITTING TOLERANCES, TUBE WALL THICKNESS, AND THE LUBRICITY OF NUT LUBRICANTS CAN RESULT IN AN IMPROPERLY ASSEMBLED TUBE FITTING CONNECTION.

A -Two ferrule A-LOK® compression port



Z -Single ferrule CPI™ compression port



F -ANSI/ASME B1.20.1 Internal pipe threads



V -VacuSeal face seal port



Q -UltraSeal face seal port



M -ANSI/ASME B1.20.1 External pipe threads



WARNING

FAILURE OR IMPROPER SELECTION OR IMPROPER USE OF THE PRODUCTS AND/OR SYSTEMS DESCRIBED HEREIN OR RELATED ITEMS CAN CAUSE DEATH, PERSONAL INJURY AND PROPERTY DAMAGE.

This document and other information from Parker Hannifin Corporation, its subsidiaries and authorized distributors provide product and/or system options for further investigation by users having technical expertise. It is important that you analyze all aspects of your application and review the information concerning the product or system in the current product catalog. Due to the variety of operating conditions and applications for these products or systems, the user, through its own analysis and testing, is solely responsible for making the final selection of the products and systems and assuring that all performance, safety and warning requirements of the application are met.

The products described herein, including without limitation, product features, specifications, designs, availability and pricing, are subject to change by Parker Hannifin Corporation and its subsidiaries at any time without notice.

ALL PARKER VALVES MUST PASS A RIGID OPERATIONAL AND LEAKAGE TEST BEFORE LEAVING THE FACTORY. IT IS RECOMMENDED AFTER ANY REASSEMBLY, THE VALVE SHOULD BE TESTED BY THE USER FOR OPERATION AND LEAKAGE. IF THESE INSTRUCTIONS ARE NOT FULLY COMPLIED WITH, THE REPAIRED PRODUCT MAY FAIL AND CAUSE DAMAGE TO PROPERTY OR INJURY TO PERSONS. PARKER HANNIFIN CANNOT ASSUME RESPONSIBILITY FOR PERFORMANCE OF A CUSTOMER SERVICED VALVE.

