



## MRC MkII

User Manual  
(Datalogging)



**Analox Limited**  
15 Ellerbeck Court, Stokesley Business Park,  
North Yorkshire, TS9 5PT, UK  
**T:** +44 (0)1642 711400 **F:** +44 (0)1642 713900  
**W:** [www.analox.net](http://www.analox.net) **E:** [info@analox.net](mailto:info@analox.net)



**+44 7917  
764348**

**MRC MkII**  
**User Manual (Datalogging)**

---

This page is intentionally blank.

## Table of Contents

<b>1</b>	<b>Caution – Hazard information .....</b>	<b>5</b>
1.1	Gas outlet port .....	5
1.2	Oxygen sensor .....	5
1.3	Battery .....	5
<b>2</b>	<b>Introduction .....</b>	<b>6</b>
<b>3</b>	<b>Operation.....</b>	<b>7</b>
<b>4</b>	<b>Installing batteries .....</b>	<b>9</b>
<b>5</b>	<b>Connecting an external supply.....</b>	<b>10</b>
<b>6</b>	<b>Setting alarm levels .....</b>	<b>11</b>
<b>7</b>	<b>Calibration .....</b>	<b>12</b>
7.1	Use of calibration gas.....	13
7.2	Oxygen sensor calibration.....	13
7.3	Carbon dioxide sensor calibration .....	14
7.4	Select factory default settings.....	15
<b>8</b>	<b>Data Logging .....</b>	<b>16</b>
8.1	Installation of Data Logging Software on a PC .....	16
8.2	Data Logging Program Overview .....	17
8.3	Data logging configuration.....	18
8.4	Data logging retrieval of data .....	19
8.5	Data logging data analysis .....	20
<b>9</b>	<b>Maintenance .....</b>	<b>22</b>
<b>10</b>	<b>Oxygen sensor replacement .....</b>	<b>23</b>
<b>11</b>	<b>Specification .....</b>	<b>24</b>
<b>12</b>	<b>Disposal.....</b>	<b>26</b>

## **Package contents check**

- a) MRC MkII main unit
- b) External power supply cable
- c) Rs232 lead
- d) User manual
- e) Test certificate

# **1 Caution – Hazard information**

## **1.1 Gas outlet port**

The Gas Outlet Port must never be blocked or restricted. The exhaust adaptor minimises the risk of the port being inadvertently blocked. If the port is blocked, internal damage to the sensor arrangement may occur.

## **1.2 Oxygen sensor**

When the life of the sensor has expired or it is leaking or otherwise damaged it must be disposed of safely in accordance with local regulations.

The sensor contains Potassium Hydroxide (KOH) solution which is hazardous. In the event of contact, apply the following First Aid procedures:

CONTACT TYPE	EFFECT	FIRST AID PROCEDURE
Skin	Potassium Hydroxide is corrosive. Skin contact could result in a chemical burn.	Wash the affected parts with a lot of water and remove contaminated clothing. If stinging persists get medical attention.
Ingestion	Can be harmful or FATAL if swallowed	Drink a lot of fresh water. Do not induce vomiting. Get medical attention immediately.
Eye	Contact can result in the permanent loss of sight	Get medical help immediately and continue to wash with a lot of water for at least 15 minutes

## **1.3 Battery**

Never store the instrument for long periods of time with batteries installed. Corrosion of the battery terminals may occur if the batteries were to leak.

In the event of a battery leak, avoid contact of the leaking electrolyte by wearing protective gloves.

When the life of the battery has expired it should be disposed of safely in accordance with local regulations.

## **2 Introduction**

The MRC MkII is a combined oxygen and carbon dioxide (CO<sub>2</sub>) monitor. Oxygen is monitored by an electrochemical cell (refer to caution in Section 2.2) and CO<sub>2</sub> is monitored by an infra-red absorption technique.

The gas levels are indicated on two separate liquid crystal displays. The displays may be backlit by pressing a front panel switch.

The instrument will annunciate high levels of CO<sub>2</sub> and high or low levels of oxygen. The alarm set points are adjustable via operator push buttons. A sample flow alarm and a low battery alarm are also fitted.

The unit can be powered internally by alkaline batteries or by an external DC supply.

The unit is built in a waterproof enclosure. The lid of the unit should only be opened in clean, dry environments. This should only be necessary for changing batteries or fuses. The batteries will provide in excess of seven days continuous use (assuming limited use of the display backlights).

Sample gas is delivered to the instrument via a female 1/8" BSP taper fitting. The pressure at the inlet must not exceed 8 Bar. The sample pressure is internally reduced and sample gas allowed to diffuse into the gas sensors via flow adaptors. Exhaust gas from the instrument is vented via an exhaust adaptor fitted to the Outlet Port that minimises the risk of blocking the gas flow (refer to caution in Section 2.1).

The user should ensure that the instrument's gas inlet ports remain as clean as possible to prevent the internal protective membranes from becoming blocked.

### **3 Operation**

The external appearance of the instrument is as shown in Figure 1.

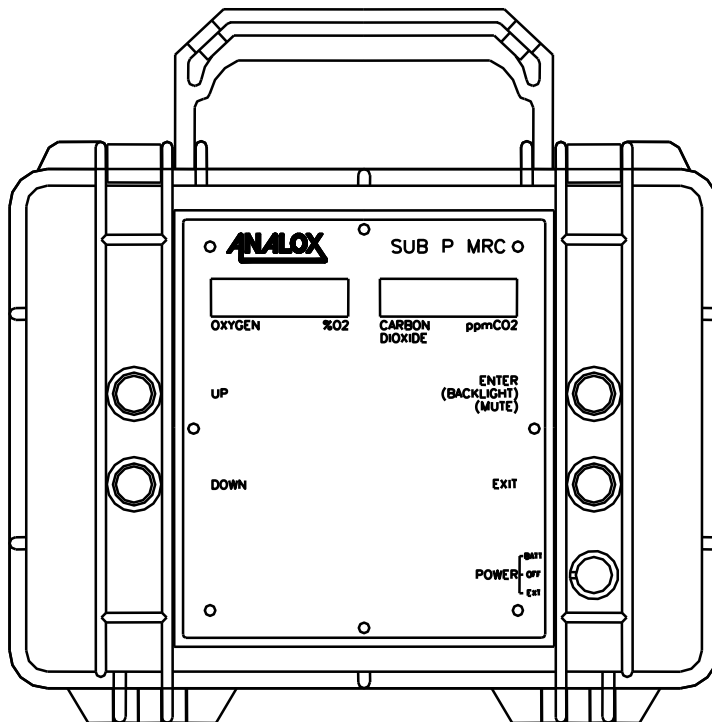

To switch the unit on, move the power switch to either the 'Battery' or 'External' position. Either an external supply or batteries must be installed in order for the unit to operate.

If the unit does not turn on, perform the following checks:

- a) check that either the external power supply or batteries are healthy
- b) check that the internal fuses in the external supply line or the battery circuit are not blown

On powering up the instrument, the sensor readings may take a short time to settle, particularly the CO<sub>2</sub> sensor, which can take about 40 seconds to 'warm up'. During this period, it is quite normal to observe erroneous sensor readings. Gas alarms are inhibited during this period.

Sensor readings are updated approximately every one second.

The choice of measurement units for each parameter is defined at the time of order and is factory set.

Oxygen readings are typically displayed in %O<sub>2</sub> (percent concentration of oxygen).

The Oxygen readout will flash 'O2 H' in the presence of an oxygen concentration greater than the high alarm set point.

The Oxygen readout will flash 'O2 L' in the presence of an oxygen concentration less than the low alarm set point.

## MRC MkII

### User Manual (Datalogging)

---

CO<sub>2</sub> readings are typically displayed in ppmCO<sub>2</sub> (parts per million of carbon dioxide) The CO<sub>2</sub> readout will flash 'CO2.h' in the presence of a CO<sub>2</sub> concentration greater than the high alarm set point.

A small amount of hysteresis is allowed to prevent alarms continually re-triggering when hovering around the alarm set point.

When there is insufficient sample line pressure to generate a sample flow, a 'No FLO' message is flashed on the display.

The instrument readings will remain accurate until the batteries are exhausted. The brightness of the backlights will fade as the batteries discharge. When the "Lo bAtt" (Low Battery) message flashes on the displays, new batteries should be inserted.

The Low Battery message is not displayed when the instrument is operating from an external supply.

Each of the alarms is accompanied by sounding of the audible buzzer. This may be muted by pressing the 'ENTER' (or MUTE) pushbutton.

The backlight is turned on by momentarily pressing the 'ENTER' (or Backlight) pushbutton on the front of the instrument. The backlight will turn off automatically after a short period. A flashing indicator is built into the Enter switch to show that the instrument is operating, and to assist locating the switch to turn on the backlight in dark conditions.

A number of fault messages may appear on the displays. Their meaning is as follows:

FAULT MESSAGE	MEANING	REQUIRED ACTION
'Cal-L' on the oxygen display	A low calibration is required for the oxygen sensor	Perform the calibration detailed in Section 7.2
'Cal-H' on the oxygen display	A high calibration is required for the oxygen sensor	Perform the calibration detailed in Section 7.2
'Cal-L' on the CO <sub>2</sub> display	A CO <sub>2</sub> Zero calibration is required for the CO <sub>2</sub> sensor	Perform the calibration detailed in Section 7.3
'Cal-H' on the CO <sub>2</sub> display	A CO <sub>2</sub> Span calibration is required for the CO <sub>2</sub> sensor	Perform the calibration detailed in Section 7.3
'Flt-d' on the CO <sub>2</sub> display	A fault has been identified with the detector within the CO <sub>2</sub> sensor	Factory repair is required
'Flt-S' on the CO <sub>2</sub> display	A fault has been identified on the infra-red source within the CO <sub>2</sub> sensor.	It is possible that the sensor has been subjected to over-range CO <sub>2</sub> . Flush through with 'clean gas' – if fault persists, factory repair required.

## **4 Installing batteries**

The instrument is fitted with four 'D' size 1.5v alkaline cells. Although the instrument will operate from other types of D size battery, their use is not recommended. The operating life using batteries such as zinc chloride or nickel cadmium will be significantly less than with alkaline. Batteries with cell voltages in excess of 1.5v must not be fitted.

The instrument is designed such that if a set of new alkaline batteries is installed, the batteries will power the instrument for in excess of seven days. It is assumed that the backlight would only be used on an occasional basis during this period, since it has the biggest effect on battery life.

To replace the batteries:

- a) In dry conditions (to prevent damage) open the lid of the instrument using the two catches beside the handle
- b) Undo the two Velcro retaining straps around the batteries
- c) Ease each battery from its clips - use one hand to grip the battery and the other hand to apply a little pressure to release the clips.
- d) Insert the new batteries, taking care to observe the polarity markings on each of the battery holders, and ensuring that the battery is retained by the clips in the holder.
- e) Refasten the Velcro retaining straps to prevent the batteries becoming dislodged from their holders inadvertently.
- f) Close the lid of the instrument, and secure in place with the two catches.

## **5 Connecting an external supply**

The external power lead supplied with the instrument terminates in a female screw-locking connector that attaches to the mating connector on the left-hand side of the unit (this connector is protected by a dust cap that must be unscrewed prior to attaching the external supply lead).

The other end of the cable is presented as stripped ends for the customer to connect a suitable plug of their choice. The colour coding is as follows:

Core Colour	Signal Name	Connect to
Red	Positive (+ve) Supply	+9 to +40 V DC
Blue	Negative (-ve) Supply	0v

The external supply must be a stable DC supply in the range 9-40V. Typical current consumption figures are shown below

Input Voltage (V DC)	Load Current (mA) (without backlight)	Load Current (mA) (with backlight)
9.0	85	155
12.0	60	175
24.0	35	150
40.0	25	140

## 6 Setting alarm levels

The alarm set points may be adjusted. To help minimise unauthorised use, access to the Alarm Menu is via a 'hidden' key combination.

Momentarily pressing the ENTER and EXIT push buttons at the same time instructs the instrument to display an alarm configuration menu in place of the O<sub>2</sub> and CO<sub>2</sub> gas measurement displays.

Initially, the displays will show the message "A.SET O2 L". Pressing UP or DOWN will cycle through all of the available menu options as shown below:

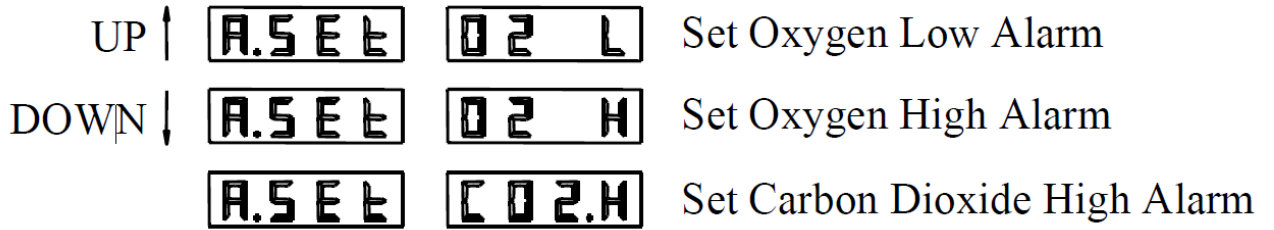

When the desired option has been selected press ENTER. Alternatively press EXIT to return to normal operation.

Pressing ENTER will cause the instrument to request the user to specify an alarm set point.

Refer to the appropriate section below for further details. The CO<sub>2</sub> display will show the current value of the alarm set point, and the user can adjust the value using the UP and DOWN keys.

Pressing EXIT will abort the set point change, and pressing ENTER will request that the set point be changed. Before the change is made, the instrument will require confirmation. Initially the word 'no' will appear on the CO<sub>2</sub> display. This must be changed to 'YES' by pressing UP or DOWN, and then confirmed by pressing ENTER. This instructs the instrument to change the alarm set point. Pressing ENTER while the display shows 'no', or pressing EXIT at any time, will prevent the set point change from taking place.

Once entering the alarm configuration menu feature, if no switches are pressed for a period of approximately 2 minutes, the instrument will return automatically to normal operation.

Note also that the backlight is turned on for a short time following any button press whilst setting alarm set points.

The description above is illustrated in Figure 2.

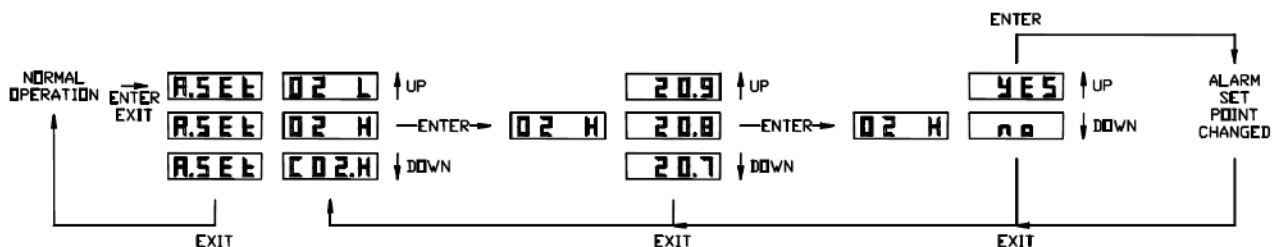

## 7 Calibration

Calibration should be performed at 3 month intervals or more frequently if desired by the user. Calibration should only be performed by suitably trained personnel familiar with handling and use of calibration gas. Any abuse of the calibration features may render the instrument inaccurate and unusable. If this should occur however, there is a facility to restore the instrument to its original factory configuration.

To help minimise unauthorised use, access to the Calibration Menu is via a 'hidden' key combination.

Momentarily pressing the four push buttons at the same time instructs the instrument to display a calibration menu in place of the O<sub>2</sub> and CO<sub>2</sub> gas measurement displays.

Initially, the displays will show the message "CAL O2 L". Pressing UP or DOWN will cycle through all of the available menu options as shown below:

	<b>CAL</b>	<b>O2 L</b>	Calibrate Oxygen Sensor Low Point
UP ↑	<b>CAL</b>	<b>O2 H</b>	Calibrate Oxygen Sensor High Point
DOWN ↓	<b>CAL</b>	<b>CO2.0</b>	Calibrate Carbon Dioxide Sensor Zero
	<b>CAL</b>	<b>CO2.5</b>	Calibrate Carbon Dioxide Sensor Span
	<b>CAL</b>	<b>FACT</b>	Restore Factory Default Settings

When the desired option is displayed press ENTER. Alternatively press EXIT to return to normal operation.

Pressing ENTER will cause the instrument to request the user to specify calibration data. Refer to the appropriate section below for further details. The CO<sub>2</sub> display will show the current value of the calibration parameter, and the user can adjust the value using the UP and DOWN keys.

Pressing EXIT will abort the calibration, and pressing ENTER will request the calibration to be performed. Before performing the calibration, the instrument will require confirmation. Initially the word 'no' will appear on the CO<sub>2</sub> display. This must be changed to 'YES' by pressing UP or DOWN, and then confirmed by pressing ENTER. This instructs the calibration to be performed.

Pressing ENTER while the display shows 'no', or pressing EXIT at any time, will prevent the calibration from taking place.

Note that the backlight does not operate during calibration.

Once entering the calibration menu feature, if no switches are pressed for a period of approximately 2 minutes, the instrument will return automatically to normal operation.

The description above is illustrated in Figure 3.

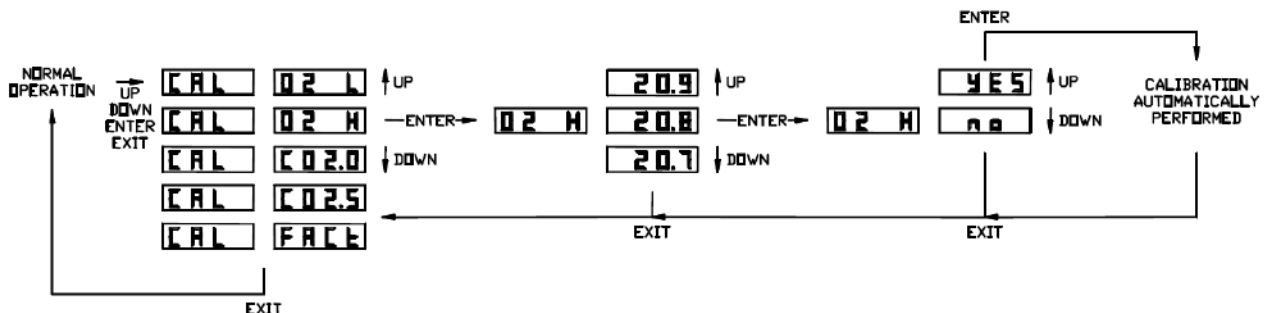

## 7.1 Use of calibration gas

The following sections require the use of calibration gas to calibrate the sensor. The instrument has been designed to allow the use of a wide range of calibration gases from various suppliers.

The descriptions that follow talk of using Calibration Air, 100% Oxygen, Zero Carbon Dioxide and Span Carbon Dioxide.

The 100% Oxygen will also suffice for the Zero Carbon Dioxide gas. It is possible to obtain a gas mixture of 20.9% oxygen, 0.5% carbon dioxide, and balance nitrogen. This would mean that only two calibration gases are needed to support all of the calibration functions. The tri-mix gas is generally more expensive, so the instrument allows the customer to choose their own options for calibration gas, depending on availability of gases.

The calibration gas is easily fed to the instrument by connecting a suitable pipe from the gas bottle regulator to the instrument sample inlet (female 1/8" BSP taper fitting). Ensure that the output pressure from the regulator does not exceed 8 Bar. Much lower pressures (just above atmospheric pressure) are adequate for calibration purposes.

Ensure as always that the exhaust port is not blocked.

## 7.2 Oxygen sensor calibration

The oxygen sensor provides a varying millivolt output proportional to the concentration of oxygen in the sample flow. Two calibration points are provided. The instrument calculates the oxygen concentration by linear interpolation between the calibration points. The calibration parameters are defined as the Percentage of oxygen in the calibration gas (e.g. 20.9 or 100.0% for instance).

Ideally the calibration points should be near to the lower and upper ends of the oxygen range.

The Low point calibration is expected to be performed using either nitrogen or calibration air.

The High point calibration is expected to be performed using 100% Oxygen.

CALIBRATION OF OXYGEN SENSOR AT NORMAL ATMOSPHERIC PRESSURE AND USE OF 2 GASES (Calibration Air =20.9% O <sub>2</sub> and 100% O <sub>2</sub> )	
1	At atmospheric pressure subject the oxygen sensor to air, using the gas inlet port and a bottle of calibration air.
2	Wait for the instrument reading to settle (allow approximately one minute)
3	Enter calibration mode by pressing all 4 push buttons momentarily
4	Select 'Cal O2' L by pressing UP/DOWN
5	Press ENTER
6	Press UP/DOWN until the display reads 20.9 (or appropriate value for the calibration air, this is the percentage concentration of oxygen in the calibration gas)
7	Press ENTER
8	Press UP to change 'no' to 'YES'
9	Press ENTER
10	Press EXIT to return to normal operation and observe after a few seconds that the instrument readout changes to the correct value (it may not have been wrong before)
11	At atmospheric pressure subject the oxygen sensor to 100% oxygen, using the gas inlet port and a bottle of calibration oxygen.
12	Wait for the instrument reading to settle (allow approximately one minute)
13	Enter calibration mode by pressing all 4 push buttons momentarily
14	Select 'Cal O2 H' by pressing UP/DOWN
15	Press ENTER

**MRC MkII**  
**User Manual (Datalogging)**

---

16	Press UP/DOWN until the display reads 100.0 (or as appropriate for the gas used, this is the percentage concentration of oxygen in the calibration gas)
17	Press ENTER
18	Press UP to change 'no' to 'YES'
19	Press ENTER
20	Press EXIT to return to normal operation and observe after a few seconds that the instrument readout changes to the correct value (it may not have been wrong before)
21	Re-subject the sensor to each of the test gases in turn to confirm that the sensor is working correctly

### 7.3 Carbon dioxide sensor calibration

The carbon dioxide sensor works using an infra-red absorption technique. It generates maximum signal when exposed to zero CO<sub>2</sub>, and minimum signal when exposed to span CO<sub>2</sub>. The microprocessor analyses this signal and applies temperature compensation and linearisation. Two calibration points are provided. The first point must always be at zero CO<sub>2</sub>. The second point should be between full scale and half of the instruments full scale (i.e. for a 5000ppm instrument, use CO<sub>2</sub> concentrations between 2500ppm and 5000ppm). The calibration parameter is defined as the parts per million (ppm) of CO<sub>2</sub> in the calibration gas (e.g. 2500ppm for instance).

CALIBRATION OF CO <sub>2</sub> SENSOR AT NORMAL ATMOSPHERIC PRESSURE USING ZERO GAS AND SPAN GAS (typically 2500ppm CO <sub>2</sub> )	
1	At atmospheric pressure subject the CO <sub>2</sub> sensor to zero CO <sub>2</sub> gas, using the gas inlet port and a bottle of calibration gas (e.g. 100% nitrogen, or 100% oxygen or calibration air with CO <sub>2</sub> removed).
2	Wait for the instrument reading to settle (allow five minutes)
3	Enter calibration mode by pressing all 4 push buttons momentarily
4	Select 'Cal CO20' (CO <sub>2</sub> Zero) by pressing UP/DOWN
5	Press ENTER
6	Press UP to change 'no' to 'YES'
7	Press ENTER
8	Press EXIT to return to normal operation and observe after a few seconds that the instrument readout changes to the correct value (it may not have been wrong before)
9	At atmospheric pressure subject the CO <sub>2</sub> sensor to 2500ppm CO <sub>2</sub> in nitrogen, using the gas inlet port and a bottle of suitable calibration gas.
10	Wait for the instrument reading to settle (allow five minutes)
11	Enter calibration mode by pressing all 4 push buttons momentarily
12	Select 'Cal CO2S' (CO <sub>2</sub> Span) by pressing UP/DOWN
13	Press ENTER
14	Press UP/DOWN until the display reads 2500 (or as appropriate for the gas used- this is the parts per million concentration of CO <sub>2</sub> in the calibration gas)
15	Press ENTER
16	Press UP to change 'no' to 'YES'
17	Press ENTER
18	Press EXIT to return to normal operation and observe after a few seconds that the instrument readout changes to the correct value (it may not have been wrong before)
19	Re-subject the sensor to each of the test gases in turn to confirm that the sensor is working correctly

## **7.4 Select factory default settings**

It is possible by the incorrect usage of the calibration features to render the instrument virtually unusable. The situation can be recovered by exercising the calibration options correctly.

It may be beneficial to a technician who is experiencing problems to be able to switch to the original factory default configuration. Each of the sensors may then also require calibration, but the readings displayed by the instrument should make sense.

To select Factory Default settings, proceed as follows:

RESTORING FACTORY DEFAULT SETTINGS	
1	Enter calibration mode by pressing all 4 push buttons momentarily
2	Select 'Cal FACT' (Cal Factory Defaults) by pressing UP/DOWN
3	Press ENTER
4	Press UP to change 'no' to 'YES'
5	Press ENTER
6	Press EXIT to return to normal operation. The instrument will restart, as if it had just been switched on.
7	Test the performance of each sensor and recalibrate as required

## 8 Data Logging

The data logging option allows the MRC MkII to record up to 3000 sensor readings and to output the stored data to a computer for analysis purposes.

The Analox data logging program once installed on your computer allows the instrument to be configured to store any combination of oxygen and carbon dioxide readings at selected time intervals varying from 10 seconds to 30 minutes.

You could for instance opt to record just the carbon dioxide reading at 30 minute intervals. In this case 3000 readings will provide an endurance of 9 weeks. Alternatively, you could opt to record both parameters at 10 second intervals, in which case the endurance would be approximately 4 hours.

By choosing an appropriate interval, you can store the maximum amount of information over a chosen time period.

A cable is supplied to connect the MRC MkII to the serial port on a PC. The cable is fitted with a 9 way female D-type connector. An adaptor will also be required if using a PC with a 25 way D-type connector.

### 8.1 Installation of Data Logging Software on a PC

The data logging software is compatible with Windows 95, 98 or 2000 software.

- 1 Insert the MRC MkII CD into the PC or laptop CD drive.
- 2 Right-click the Windows 'Start' button and select 'Open Windows Explorer'.
- 3 Locate the MRC Setup Software CD and double-click the file called 'Install'.
- 4 The DataLogInterface.exe file will be copied to C:\Analox
- 5 Navigate to the C:\Analox directory. Right click-drag the DataLogInterface.exe file to your desktop and select 'Create shortcut here'
- 6 From your desktop now double click on the new shortcut Icon that you have just created
- 7 The following screen will appear.

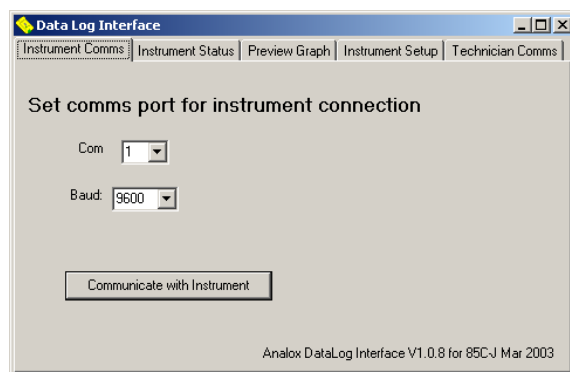

## MRC MkII

### User Manual (Datalogging)

---

8 Now connect the PC to the MRC MkII using the data lead provided and ensure that the MRC is switched on. Note whether it is connected into COM1, COM2, COM3 or COM4 on your PC. (Note if you do not have a COM port on your PC, you will also need a USB to 9 way D-type adaptor).

9 Ensure that the correct 'COM' port is selected – press the ▼ arrow adjacent to 'Com' and select 1 to 4 as appropriate. This setting will be remembered the next time you start the program.

10 Always ensure that the Baud rate is set to 9600, to which it will default.

11 Click on the 'Communicate with Instrument' button. You will see a message 'Please wait' and if successful, the 'Instrument Status' tab will be selected.

12 If you get a message 'No Reply from Instrument' check the following:

- a. The MRC MkII is switched on
- b. The D-type connector is connected between the MRC MkII and PC
- c. The correct COM port is selected.
- d. No other devices are attempting to use the COM port

Now click 'OK' to the No Reply from instrument message and retry communications.

13 When you successfully establish communications, the following screen will appear. You are now ready to use the program.

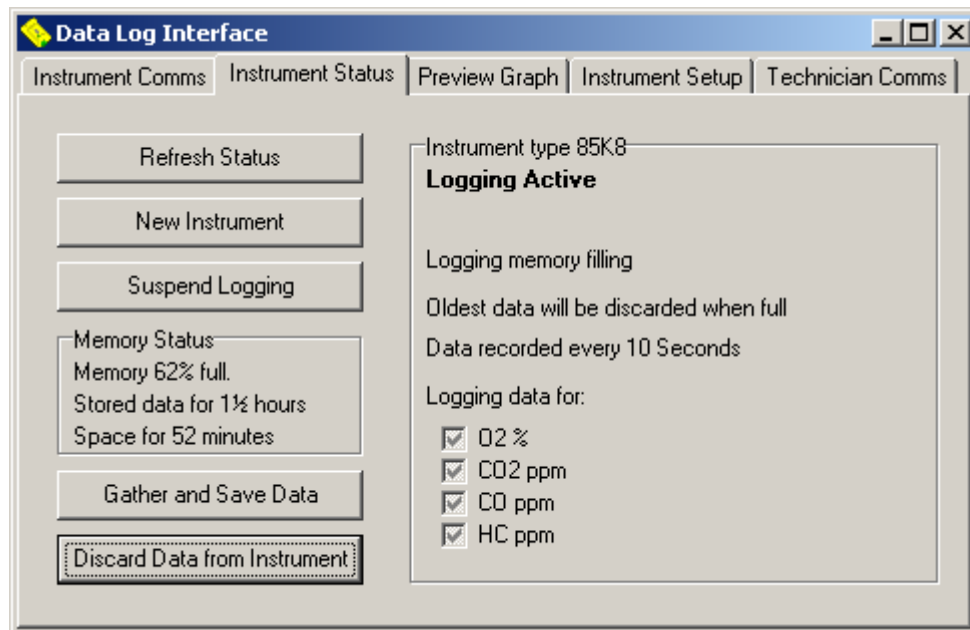

## 8.2 Data Logging Program Overview

The data logging program is split into a number of pages or tabs. These are Instrument Comms, Instrument Status, Preview Graph, Instrument Setup and Technician Comms as shown in the diagram below. Additional pages may also be accessed through the Technician Comms page.

## MRC MkII

### User Manual (Datalogging)

---

Instrument Comms appears during the installation process, the Instrument Status, Preview Graph and Instrument Setup pages are used during data logging set up, activation and data retrieval. The 'Preview Graph' is a small utility, allowing you an overview of the data that has been logged. It is not intended to replace the need for a spreadsheet. To use the graph select the variable that you wish to view and a graph will be automatically generated. This process will suspend logging; you will therefore need to click on the 'Restart logging' button on the Instrument Status page.

The Technician Comms page should not be used. It is only to be used under guidance from an Analox technician.

The Instrument status page provides a summary of the instruments data logging status and is shown in the diagram above. This page shows the Memory status of the MRC MkII. The Information Panel to the right of the screen shows us that logging is Active, i.e. the instrument is currently logging. The instrument has been configured to discard the oldest stored data when the memory is full. The instrument is recording all parameters (Oxygen and carbon dioxide) at 10 second intervals. All of these features are configurable on the Instrument Setup page. The 5 command buttons will be explained in Section 9.4.

### 8.3 Data logging configuration

Click on the 'Instrument Setup' tab and the following screen will appear:

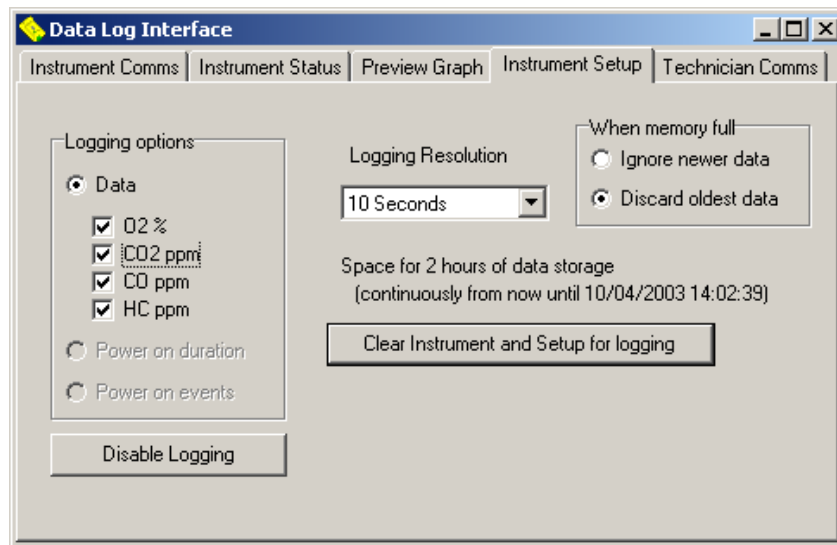

#### Disable logging:

If you do not want data logging to take place at all, press the 'Disable Logging' button. 'Logging disabled' will be shown on the Instrument Status page.

#### Logging options:

Select the data items that you wish to record from O<sub>2</sub> and CO<sub>2</sub>, by clicking on the box next to the parameter you require, if the box has been successfully selected a  will appear.

## MRC MkII

### User Manual (Datalogging)

---

#### Logging Resolution:

Select the Logging Resolution you require by clicking on the ▼ arrow, and then clicking on the time interval you want. This is the time interval between logged readings, which can be set to one of various values between 10 seconds and 30 minutes. Please be aware that the shorter the time interval, the shorter the data storage period. For example logging just CO<sub>2</sub> at 30 minute intervals will give approximately 9 weeks of continuous data storage, whereas logging O<sub>2</sub> and CO<sub>2</sub> at 10 second intervals will result in approximately 4 hours of continuous data storage. The wording 'continuous' refers to the unit logging whilst left permanently switched on. If the instrument is switched off, e.g. overnight, this time period will be extended.

**Note** there is a slight overhead every time the instrument is switched on and off, so the number of data points recorded will be slightly reduced each time the instrument is switched off and on. In normal daily use this reduction will not be apparent.

#### Full Memory:

This option enables you to specify what the instrument should do when its data logging memory is full.

You may choose to 'Ignore newer data' if for example you are conducting a specific test run, using a short logging resolution, and you only require data from that test. By ignoring new data you will ensure that you retain your test data until you have been able to download it to a PC. You may choose to 'Discard older data' if you want the instrument to essentially keep on logging for ever, and you only intend to download the data following an incident you want to investigate.

Once you have set each of the 3 options described above (Logging Data, Logging Resolution and Memory Full options), press 'Clear Instrument and Setup for Logging'. This transfers the selected options to the instrument. It also transfers the date and time from your PC to the instrument. Make sure the Date and Time on your PC are correct!

You will be asked to confirm whether logging should 'Start Immediately', or the next time the instrument is switched on ('Start at next Power-Up'). This enables you to optimise the data storage time by leaving the instrument switched off until it is required.

## 8.4 Data logging retrieval of data

1. Start up the Data logging program by clicking on the shortcut on your desktop.
2. Click on the 'Communicate with Instrument' button. This will automatically take you to the Instrument Status page.
3. The Memory Status will show the Status of the instrument at the present moment in time. If you wish to refresh this status simply click the 'Refresh Status' button.
4. Press the 'Suspend Logging' button if you wish to stop the MRC MkII storing data temporarily. The MRC MkII will automatically resume the next time it is switched on, or when the Restart Logging 'button' is pressed.

## **MRC MkII**

### **User Manual (Datalogging)**

---

5. Press the 'Gather and Save Data' button to transfer data from the MRC MkII to the PC. Note this will automatically Suspend logging if you have not already done so.
6. Please wait patiently while the instrument transfers data to the PC. An estimate is provided of the time required for the data transfer to complete. If no problems occur in the transfer process, a screen will appear inviting you to save the log file.
7. In the Save as type box, select the type of file that you wish to save. Let us assume that we are trying to create a Microsoft Excel spreadsheet. Therefore select an Excel compatible .csv file. (CSV stands for a Comma Separated Variable file, and is a format that most spreadsheet programs will recognise).
8. Now select the folder and enter the filename that you wish to use for the file. The program will remember the filenames that you have used previously. Initially the default will be c:\My Documents\0Analox00. If you choose to retain this format, the program will automatically suggest the next number 0Analox01, 0Analox02 etc for future files. The 0 at the start is meant to signify which instrument you are transferring data from if using multiple instruments.
9. You will then be asked if you want to delete the data already in the instrument. Answer Yes or No as appropriate. Answering 'Yes' will avoid retrieving the same data again at a future date. You will then be asked when you want logging to commence, click 'Start Immediately' or 'Start at next Power-Up' as appropriate.

*You may choose not to discard the data until you have inspected the data for correctness and click No. This will leave the data shown in the Memory Status. You can then use the 'Discard the Data from the Instrument' button to delete the data at your own discretion. You will need to reactivate the logging by clicking the 'Restart logging' button.*

10. If you are retrieving data from a number of instruments, connect the PC to the next instrument and press the 'New Instrument' button. Retrieve the data as explained in steps 4 -8.

## **8.5 Data logging data analysis**

Microsoft Excel is not provided with the Analox system. If you do not have a copy of Microsoft Excel, other spreadsheets will also allow access to the data. These instructions are limited however to the use of Excel. You may choose to access the data in a variety of ways, either via Excel or Windows Explorer. These instructions are based on loading the file from Excel.

1. Start Microsoft Excel from your Start Menu or from your desktop.
2. Select File, Open and then navigate to the folder in which you chose to store the data file (e.g. in c:\My Documents).
3. Select files of Type 'Text Files'. All of the CSV files in the chosen folder will appear. Click on the file that you wish to inspect, and then click on 'Open'
4. The data from the file will then appear in a standard Excel Worksheet.
5. Note that the first column of data is the date and time of the reading. This field is too wide to fit in the standard width of the cell. Click on the 'A' at the top of the column, and then select Format, Column, and Autofit Selection. Or simply drag the column separator between 'A' and 'B' to achieve the right width.

## **MRC MkII**

### **User Manual (Datalogging)**

---

6. Select the right format for the Date and Time. Click on 'A' at the top of Column A, then press Format, Cells. On the 'Number' tab, under category, select 'Date', and then under 'Type' select 03-04-97 13:30 or similar.
  
7. Now to graph the CO<sub>2</sub> reading, click on the 'A' at the top of Column A, then press and hold the CTRL key on the keyboard, and click on the 'C' at the top of the CO<sub>2</sub> column. Then click on Insert, Chart (or press the small Chart Icon on the toolbar if you have one).
  
8. Under 'Chart Type' choose XY scatter, and under 'Chart Sub Type' choose the type of lines that you wish on the chart. (Hint – Use Scatter with data points connected by lines).
  
9. Now press 'Finish' or choose 'Next' if you wish to refine the appearance of the graph.
  
10. A graph will appear on the screen with the x-axis showing the date and time, and the y-axis showing the CO<sub>2</sub> reading.
  
11. The basic appearance of the graph can now be edited, but to do so requires familiarity with Microsoft Excel. There are several books available at almost any computer store on this subject.

## **9 Maintenance**

Maintenance consists of the following tasks:

<b>FREQUENCY</b>	
Daily	Check that the instrument is maintained in a clean state. In particular ensure that the gas inlet and outlet ports are unobstructed. When necessary, clean the instrument with a dampened cloth. Take care not to obstruct the Gas Outlet when cleaning.
	Check the batteries; change them when the low battery message flashes on the display.
Three Monthly	Check the accuracy of the readings by subjecting the instrument to calibration gas. If necessary, recalibrate the instrument as detailed in Section 7
Annually	Where the instrument is used as a standby for use in emergencies, replace the main batteries as detailed in Section 4

## 10 Oxygen sensor replacement

The O<sub>2</sub> sensor is a consumable item, it will typically last 2-3 years in 20.9% O<sub>2</sub> at normal temperature and pressure.

Prior to replacing the O<sub>2</sub> sensor, please check if there is a modification marker label (Figure 1), inside the instrument which can be found on the left hand inside of the base between the External Power and RS232 Communications Port. If the label is present please change the O<sub>2</sub> sensor following the instructions below. Please ensure you calibrate the instrument as detailed in Section 8 prior to use.

If the Modification Marker Label is **not** present the instrument should be returned to Analox Ltd, for upgrade, during which the Oxygen sensor will be replaced and the unit calibrated.



Figure 1

Upon receiving your new Oxygen Sensor, remove the old one by disconnecting the sensor from the processor board (Figure 2), disconnect the flow adaptor (Figure 3), loosen the locking ring (Figure 4), so that the sensor will slide from the bracket (Figure 5).



Figure 2



Figure 3



Figure 4



Figure 5

To fit the new sensor, repeat the above process in reverse order, then calibrate as described in Section 8.2

## 11 Specification

Power Source	External DC supply. 9-40V DC, with regulation of better than +/- 300mV.	
Batteries	4 x 1.5V Alkaline 'D'	
Fuses	Individual fuses for the two supply sources, fuses 1A-T.	
Display Panel	2 x 4 character LCD displays, character size 8mm x 5mm Oxygen and carbon dioxide	
Operator controls	4 x Pushbuttons to control User interface and display backlight. Backlight times out after 10 seconds when turned on.	
Oxygen Sensors	Analox 9100-9212-9HSUB-1 oxygen sensor with 2-3 year life in air at normal atmospheric pressure.	
	Range	0-100 % O <sub>2</sub>
	Accuracy	< 1% of reading Standard temp range < 2% of reading Extended temp range
CO <sub>2</sub> Sensor	Analox BL5 low power, long life infra-red sensor with microprocessor applied temperature compensation and linearisation	
	Range	0-5000 ppm
	Accuracy	<2% of range at constant temperature and pressure
		<6% of range over standard temp range
<9% of range over upper extended temp range		
<11% of range over lower extended temp range		
Gas Inlet	Female 1/8" BSP taper fitting	
Gas Outlet	6mm O/D push fit connector, fitted with an exhaust adaptor designed to minimise the risk of blocking the outlet.	
Standard Temperature	0°C to 40°C	
Extended Operating Temperature	-10°C to 45°C	
Storage Temperature	-10°C to 50°C	
Dimensions	241 x 190 x 140 mm (9.5x7.5x5.5 inches)	
Weight	2.2kg (with batteries installed)	



## **12 Disposal**



According to WEEE regulation this electronic product cannot be placed in household waste bins. Please check local regulations for information on the disposal of electronic products in your area.