

ADM Aspida

Quick Start Guide

1. Safety Information



WARNING: IF ENABLED, THE ADM ASPIDA USES HIGH VOLUME WARNING ALARMS OF UP TO 110DB (MANUALLY ACTIVATED BY HOLDING THE  BUTTON). TO AVOID INJURY, MINIMISE EXPOSURE TO THE SOUNDER. WHERE FITTED, THE ELECTROCHEMICAL OXYGEN SENSOR CONTAINS TOXIC COMPOUNDS. TAKE CARE AND AVOID CONTACT IF THIS IS DAMAGED.

www.analoxgroup.com/products/adm-aspida

Scan the QR code to visit the Analox ADM Aspida web page



Document ref: P0132-800--06



2. Package Contents Checklist

- Analox ADM Aspida
- Oxygen sensor (Not shown)
- Oxygen sensor insertion/extraction tool (Not shown)
- Universal charger power supply
- Calibration adapter (single or dual including + 300mm of tubing)
- Test Certificate
- Quick Start Guide
- Optional faceplate assembly (as applicable)



3. Optional Faceplate Installation Dimensions

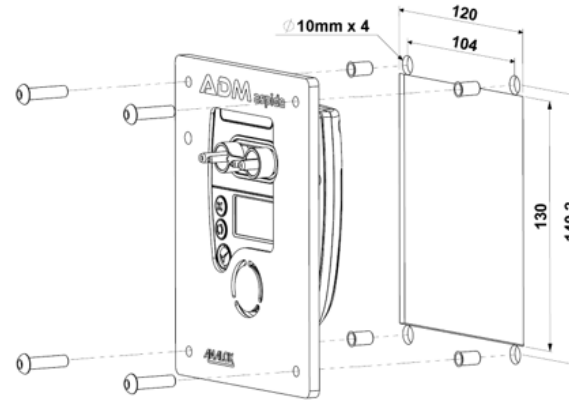

4. Fitting the ADM Aspida (with optional faceplate)

- Panel cut-out should be made as per the detail above.
- The cage nuts (available as part of the optional fixing kit – PN. P0132-602) should be placed through the four holes and secured using the Pozi Pan screws from the fixing kit, once tightened remove the screws.
- Connect the jack plug from the supplied PSU to the rear of the instrument.
- Fit the flow adaptor and feed the pipe through the hole in the front panel.
- Connect the free end of the pipework to the supply gas line using a suitable 6mmOD pneumatic connector.
- Align the ADM Aspida mounting holes with the cage nuts in the panel and secure with the supplied Pozi Pan screws.

5. Providing Power to the ADM Aspida



WARNING: THE ANALOX ADM ASPIDA SHOULD ONLY USE NIMH BATTERIES – PN. P0132-603. CONSULT THE USER MANUAL FOR ADDITIONAL BATTERY CHARGING SAFETY INFORMATION.

- With the mains charger disconnected from the wall outlet, insert the power jack into the socket on the rear of the ADM Aspida prior to instrument panel installation.
- Insert the mains charger into the wall outlet.
- Switch on the mains outlet.
- A full charge of the battery backup will complete within 4.5 hours.



NOTE: ADM ASPIDA BATTERIES WILL CHARGE WITH THE DEVICE BOTH SWITCHED ON OR OFF.

6. Switching the ADM Aspida On & Off

To switch the ADM Aspida on, press the  button.



NOTE: ON START-UP, THE SENSORS HAVE A SHORT WARM-UP PERIOD. LIVE GAS VALUES ARE NOT DISPLAYED UNTIL THE SENSORS HAVE COMPLETED THEIR WARM-UP. FOR OXYGEN, THE WARM-UP TAKES 15 SECONDS. FOR CARBON DIOXIDE, THE WARM-UP TAKES 30 SECONDS. SENSOR WARM-UP WILL BE SHOWN ON THE DISPLAY.

To switch off the device, from the main display press and hold the  button until the screen goes blank then release the button.

To return to the main display press and release the  button as required to exit the menus.

7. The Main Display



1. Man-down detection enabled icon (not used by ADM)
2. Clock
3. Measured gas types (dual sensor)
4. Measured gas values (dual sensor)
5. Measured gas units (dual sensor)
6. Quiet mode enabled icon
7. Pressure (mbar – see manual)
8. Battery status icon
9. Measured gas type (single sensor)
10. Measured gas value (single sensor)
11. Measured gas units (single sensor)

Consult the user manual for information on alarm, calibration and service indicator icons which are also shown in the units area.

8. Oxygen Sensor Installation

Remove the top 4 screws from the device using a cross-head screwdriver as shown. Retain the screws along with the sealing washers.



Gently remove the sensor cap as shown.



WARNING: DO NOT TOUCH THE INSIDE OF THE (INSTRUMENT OTHER THAN AS NOTED IN THESE INSTRUCTIONS) WITHOUT APPROPRIATE ANTI-STATIC PRECAUTIONS.

Remove the new sensor from its packaging. Oxygen sensors are supplied in sealed bags. Before the bag is opened check that the sensor has not leaked. If it has, then please refer to the safety information in the user manual. Insert the sensor into the extraction tool, aligning the pins with the alignment rib.



Align the extraction tool rib with the Aspida case alignment mark as shown. Push the tool and sensor gently downwards into the case until the sensor locates firmly within its socket.



Hold the top ring of the extraction tool gently, without squeezing the grip and lift the tool vertically upwards to remove the extraction tool whilst leaving the new sensor in place. (A gentle twisting of the tool may help to separate the tool from the sensor).



Replace the sensor cap ensuring that the oxygen cell is centrally sited in the gas port with the white gasket visible around the whole of the gas port. If misaligned, remove the sensor cap, and adjust the oxygen cell position using the extraction tool. Then refit the cap and recheck the alignment.



Holding the sensor cap in position, turn the unit over and fit the 4 crosshead screws (including washers) into the rear of the case as shown.



WARNING: ANY NEW SENSOR FITTED TO A DEVICE WILL TAKE TIME TO SETTLE TO A STABLE READING. FOR THIS REASON, ONCE THE SENSOR HAS BEEN FITTED, THE DEVICE SHOULD BE LEFT UN-POWERED FOR AT LEAST 2 HOURS BEFORE ATTEMPTING TO POWER-UP AND CALIBRATE.

Power the device and allow the sensor(s) to warm up. The new oxygen sensor will require calibration and may be showing a fault due to an over-range reading (this is possible for a new sensor).



NOTE: THE OXYGEN SENSOR MAY REQUIRE FURTHER FRESH AIR CALIBRATIONS AS THE SENSOR CONTINUES TO SETTLE. THE OXYGEN READING SHOULD BE CHECKED FREQUENTLY IN FRESH AIR DURING THE FIRST FEW HOURS OF OPERATION WITH A NEW OXYGEN SENSOR.

To ensure the sensor replacement reminder (🔁 icon) occurs at the correct time for the new sensor, the reminder should be reset using the Aspida configuration software. See the Aspida software configuration manual for instructions.

Disposal

WEEE statement



According to WEEE regulation this electronic product cannot be placed in household waste bins. Please check local regulations for information on the disposal of electronic products in your area.

Service and Support



Scan the QR code to visit the Analox Technical & Service Support web page



<https://customersupport.analox.net/support/home>

UK / Global info@analoxgroup.com +44 (0)1642 711 400
US Office ussales@analox.biz (714) 891 4478 Toll Free: (877) 723 3247

analoxgroup.com

Emergency Contact: UK / Global 0800 211 8160 US (855) 711 4994