



# ADM Aspida

## User Manual

Commercial in Confidence

**UK Office**  
15 Ellerbeck Court,  
Stokesley Business Park,  
North Yorkshire, TS9 5PT, UK

**US Office**  
15121 Graham Street #B106,  
Huntington Beach, California,  
92649

**UK / Global**  
info@analoxgroup.com  
+44 (0)1642 711 400

**US Office**  
ussales@analox.biz  
(714) 891 4478  
Toll Free: (877) 723 3247



## List of Contents

<b>1</b>	<b>Safety information</b> .....	<b>5</b>
<b>2</b>	<b>Package contents checklist</b> .....	<b>6</b>
<b>3</b>	<b>Overview</b> .....	<b>7</b>
3.1	ADM Aspida main features .....	8
<b>4</b>	<b>Installation</b> .....	<b>9</b>
4.1	Fitting the oxygen sensor .....	9
4.2	Installation of the ADM Aspida (Using faceplate kit) .....	13
4.3	Gaining access to the ADM Aspida (When faceplate is fitted) .....	15
<b>5</b>	<b>Charging the ADM Aspida</b> .....	<b>17</b>
<b>6</b>	<b>Operation</b> .....	<b>19</b>
6.1	Button functions .....	19
6.2	Switching the device on/off .....	19
6.3	User registration .....	20
6.4	The main display .....	20
6.5	Screen saver .....	21
6.6	Battery status .....	21
6.7	Menus .....	22
6.8	Common menu items.....	22
6.9	Gas alarms.....	23
6.10	Global alarm options .....	24
6.11	Alarm set-points .....	24
6.12	Alarm latching .....	26
6.13	Alarm muting .....	26
6.14	Quiet alarms .....	26
6.15	Data logging .....	27
6.16	Panic alarm.....	27
6.17	Time-weighted average (TWA) monitoring of carbon dioxide .....	28
6.18	Maintenance reminders.....	29
6.19	Calibration reminders .....	29
6.20	Sensor replacement reminders.....	30
6.21	Faults .....	30
6.22	Troubleshooting .....	31
<b>7</b>	<b>Maintenance</b> .....	<b>32</b>
7.1	Spares & accessories .....	32
7.2	Calibration.....	33
7.3	Sensor calibration .....	33
7.4	CO <sub>2</sub> sensor replacement .....	37
7.5	Oxygen sensor replacement.....	37
7.6	Cleaning.....	45
<b>8</b>	<b>Specifications</b> .....	<b>46</b>
<b>9</b>	<b>Warranty information</b> .....	<b>48</b>
<b>10</b>	<b>Disposal</b> .....	<b>49</b>
10.1	WEEE statement.....	49
10.2	Oxygen sensor disposal.....	49
<b>11</b>	<b>UK Declaration of Conformity</b> .....	<b>50</b>
<b>12</b>	<b>Declaration of conformity</b> .....	<b>51</b>



## **1 Safety information**



**WARNING: READ THE SAFETY INFORMATION FULLY BEFORE USING THE ADM ASPIDA.**



**WARNING: DO NOT ATTEMPT TO CHARGE THE BATTERIES WHILE THE DEVICE IS INSIDE THE HYPERBARIC CHAMBER.**

### **High volume audible alarm**

The ADM Aspida employs high volume warning alarms with a sound pressure level at 1m of 95dB in the case of normal gas alarms.

### **Electrochemical oxygen sensor**

The oxygen sensor used in the ADM Aspida is an electrochemical sensor which contains potassium hydroxide. Under normal conditions the sensor is sealed. To prevent leakage, the unit must not be exposed to temperatures outside the specified range, or be exposed to organic vapours, which may cause physical damage to the body of the sensor. The unit must not be stored in areas containing organic solvents or in flammable liquid stores.

## 2 Package contents checklist

### ADM Aspida (Single & Dual)

- a) ADM Aspida main unit
- b) Oxygen sensor (Not shown)
- c) Oxygen sensor insertion/extraction tool (Not shown)
- d) Universal charger/power supply (Including adaptors)
- e) Calibration adaptor (Including 300mm of tubing, single or dual)
- f) USB communication cable (Not shown)
- g) Test Certificate
- h) Quick Start Guide

#### Single variant



#### Dual variant



### **3 Overview**

The ADM Aspida is a purpose designed compact portable gas monitor capable of continuous monitoring of both carbon dioxide (CO<sub>2</sub>) and oxygen (O<sub>2</sub>).

The ADM Aspida gives clear audible and visible warning of potentially dangerous gas levels. A high-resolution Organic Light-Emitting Diode (OLED) display shows clear, live gas levels in all light conditions.

The ADM Aspida is housed in a robust, IP65 splash proof enclosure. The instrument operates using rechargeable battery technology, allowing it to run for more than 12 hours continuously between charges. An ADM Aspida allows for easy replacement of the rechargeable batteries with standard, AA type non-rechargeable batteries in circumstances where recharging is not possible.

The ADM Aspida offers continuous monitoring of O<sub>2</sub>, CO<sub>2</sub> or dual gas. The ADM Aspida can be retrofitted with a faceplate allowing for panel mounting, see section 7.1 for the faceplate kit part number.

**Table 1 ADM Aspida factory default settings**

<b>Parameter</b>	<b>Setting</b>
O <sub>2</sub> Alarms	%Vol Version
	18%
	19.5%
	23%
CO <sub>2</sub> Alarms	%Vol Version
	0.5%
	1.5%
	4%
Alarm Latch State	Non-latching
Alarm Muting State	Mutable
Man-down State	Disabled
Logging Rate	30 seconds

### 3.1 ADM Aspida main features

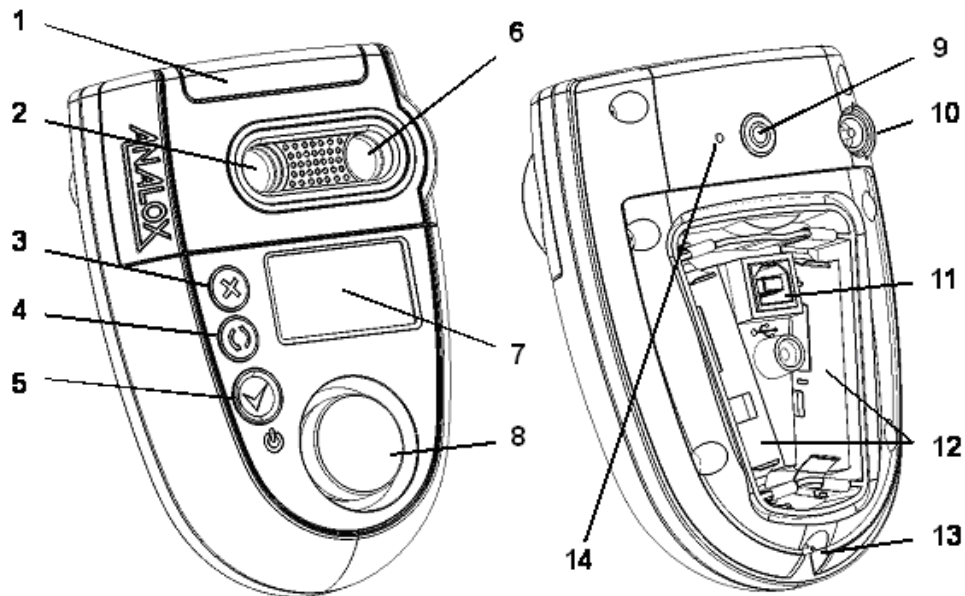

**Figure 1** Main features

- 1) Alarm, fault and OK indicators
- 2) Carbon dioxide gas port
- 3) Cancel/exit/panic-alarm button
- 4) Cycle button
- 5) Confirm/on/off button
- 6) Oxygen gas port (if sensor fitted)
- 7) OLED display
- 8) Horn
- 9) Belt loop mount point
- 10) Charger socket
- 11) USB communication socket
- 12) Battery compartments
- 13) Lanyard pin
- 14) Breather (pressure equalisation) hole – do not cover

## 4 Installation

### 4.1 Fitting the oxygen sensor

- 1] Remove the top 4 screws from the device using a cross-head screwdriver as shown in Figure 2. Retain the screws along with the sealing washers.



**Figure 2** Remove the sensor cap screws

- 2] Gently remove the sensor cap as shown in Figure 3.



**Figure 3** Remove the sensor cap



**WARNING:** DO NOT TOUCH THE INSIDE OF THE (INSTRUMENT OTHER THAN AS NOTED IN THESE INSTRUCTIONS) WITHOUT APPROPRIATE ANTI-STATIC PRECAUTIONS.

- 3] Remove the new sensor from its packaging. Oxygen sensors are supplied in sealed bags. Before the bag is opened check that the sensor has not leaked – if it has, then please refer to the safety information at the start of this section.



**Figure 4**      ***Insert the new sensor into the extraction tool***

- 4] Insert the new sensor as show in Figure 5, ensuring that the two pins of the new sensor are away from, but align with the extraction tool alignment rib, as shown.



**Figure 5**      ***Align the new sensor in the extraction tool***

- 5] Align the extraction tool rib with the ADM Aspida case alignment mark as shown in Figure 6.



**Figure 6**      ***Align the new sensor with the ADM Aspida device***

- 6] Push the tool and sensor gently downwards into the case until the sensor locates firmly within its socket.

- 7] Hold the top ring of the extraction tool gently, without squeezing the grip (Figure 7) and lift the tool vertically upwards to remove the extraction tool whilst leaving the new sensor in place. (A gentle twisting of the tool may help to separate the tool from the sensor).



**Figure 7** *Remove the extraction tool*

- 8] Replace the sensor cap ensuring that the oxygen cell is centrally sited in the gas port with the white gasket visible around the whole of the gas port. If misaligned, remove the sensor cap, and adjust the oxygen cell position using the extraction tool. Then refit the cap and recheck the alignment.

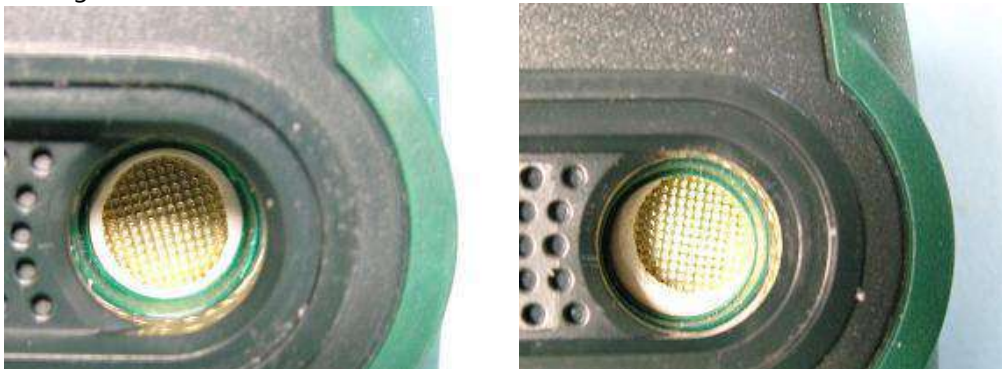

**Figure 8** *Centralised and misaligned sensors*

- 9] Holding the sensor cap in position, turn the unit over and fit the 4 crosshead screws (including washers) into the rear of the case as shown in. Figure 9.



**Figure 9**      *Replace the sensor cap and secure the screws*



**WARNING:**      **ANY NEW SENSOR FITTED TO A DEVICE WILL TAKE TIME TO SETTLE TO A STABLE READING. FOR THIS REASON, ONCE THE SENSOR HAS BEEN FITTED, THE DEVICE SHOULD BE LEFT UN-POWERED FOR AT LEAST 2 HOURS BEFORE ATTEMPTING TO POWER-UP AND CALIBRATE.**

- 10] Once the sensor has been allowed to settle, replace the batteries and fit the battery cover.
- 11] Power the device and allow the sensor(s) to warm up. The new oxygen sensor will require calibration and may be showing a fault due to an over-range reading (this is possible for a new sensor). To calibrate the oxygen sensor, follow the instructions in the section 0.



**NOTE:**      **THE OXYGEN SENSOR MAY REQUIRE FURTHER FRESH AIR CALIBRATIONS AS THE SENSOR CONTINUES TO SETTLE. THE OXYGEN READING SHOULD BE CHECKED FREQUENTLY IN FRESH AIR DURING THE FIRST FEW HOURS OF OPERATION WITH A NEW OXYGEN SENSOR.**

To ensure the sensor replacement reminder (↔ icon) occurs at the correct time for the new sensor, the reminder should be reset using the ADM Aspida configuration software. See the Aspida software configuration manual for instructions.

## **4.2 Installation of the ADM Aspida (Using faceplate kit)**

The ADM Aspida will come with the battery cover secured to the main unit.

An optional ADM Aspida faceplate kit is available to purchase separately from Analox, see section 7.1 for details.

Details on how to fit the faceplate are provided with the kit.

If using the faceplate kit, the cut-out required for the ADM Aspida with faceplate is shown below.

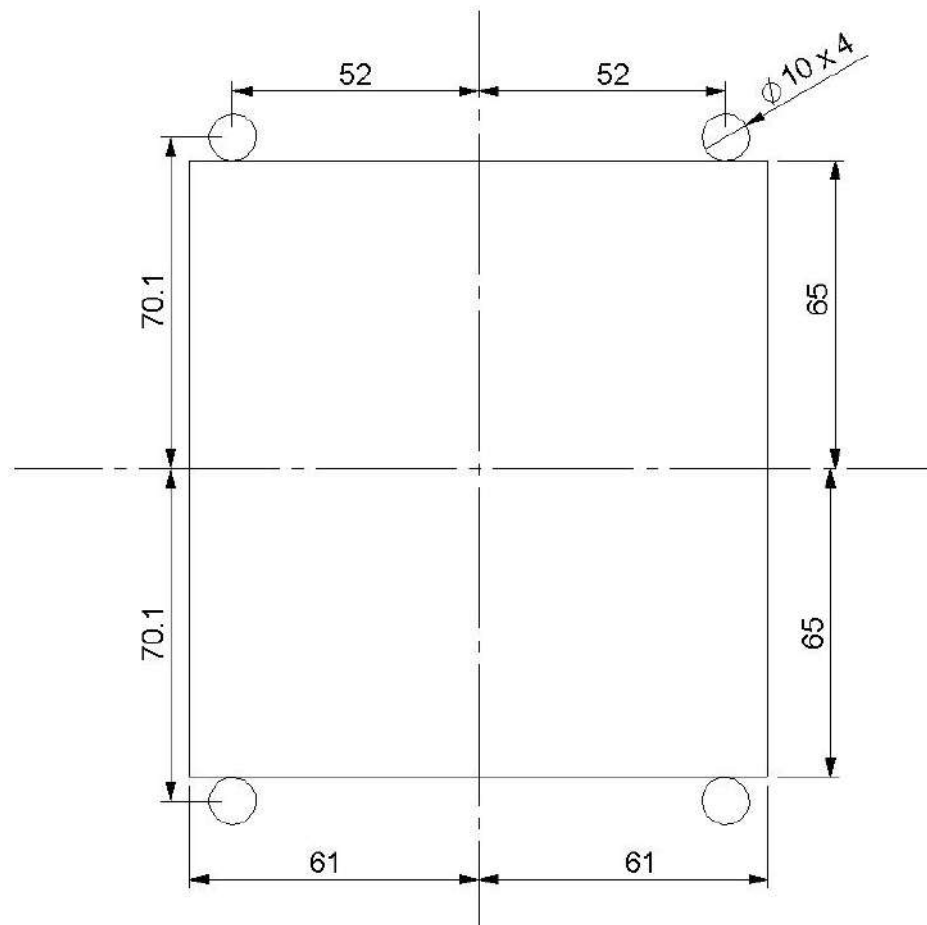

Optional fixing kits are available from Analox, see spares and accessories list at section 7.1

To install the ADM Aspida into your panel, place the captive nuts from the fixing kit through each of the 10mm diameter holes in the panel, then while securing the captive nuts screw in the M5 x 25mm Pozi Pan screws from the fixing kit until the captive nut comes back on itself.

Fit the flow adaptor and feed the pipe through the 6.5mm hole in the front panel and connect the free end of the 6mmOD x 4mmID pipework to the supply gas line using a suitable 6mmOD pneumatic connector.

Ensure the supplied 9V PSU's DC jack is connected to the rear of the unit.

Remove the screws and align the ADM Aspida front panel mounting holes up with the captive nuts, then re-insert the M5 x 25mm Pozi Pan screws through and tighten.

The illustrations below show the installation of the ADM with the pipework installation.

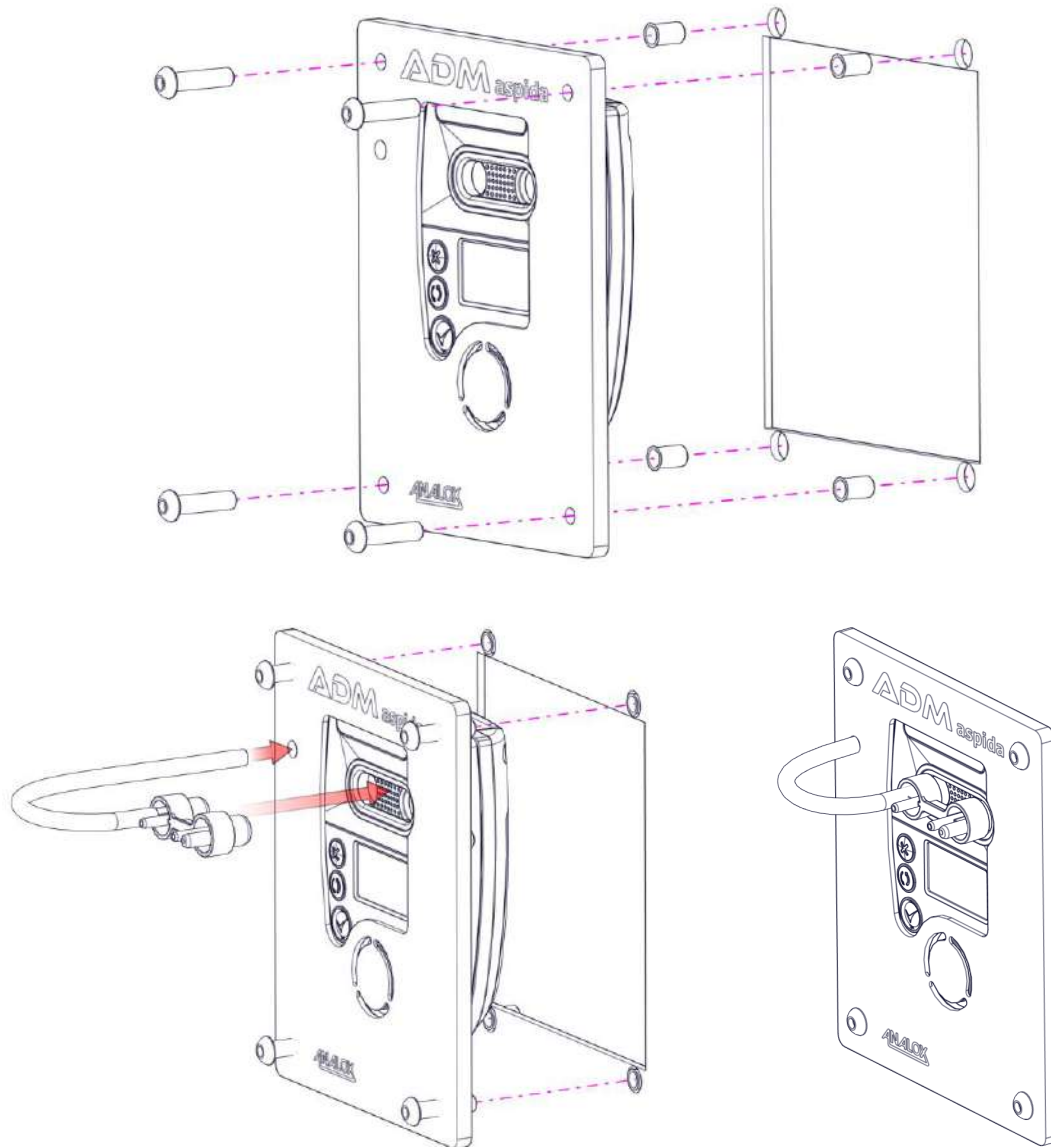

### **4.3 Gaining access to the ADM Aspida (When faceplate is fitted)**

To gain access to the ADM Aspida for either USB connection or sensor change the following steps should be followed.

Firstly, remove the ADM Aspida from the instrument panel by removing the four M5 x 25mm Pozi Pan screws.

Turning the ADM Aspida over, remove the two left most screws and washers from the tie bases.



You should now be able to remove the ADM Aspida main unit from the panel and be able to remove the battery cover as described in section 0Battery installation.

The ADM Aspida is powered by a universal mains adaptor, 90-264VAC to 9VDC, with a 2.1mm x 5.5mm x 12mm DC jack plug – centre pin positive. Battery backup is available as an optional extra, this can be supplied by Analox, see spares and accessories list at section 7.1

To gain access to the battery compartment, undo the screw in the centre of the battery cover on the rear of the device and lift the cover off. Before removing batteries from the device, ensure that it is switched off and that the mains charger and USB cable are disconnected.

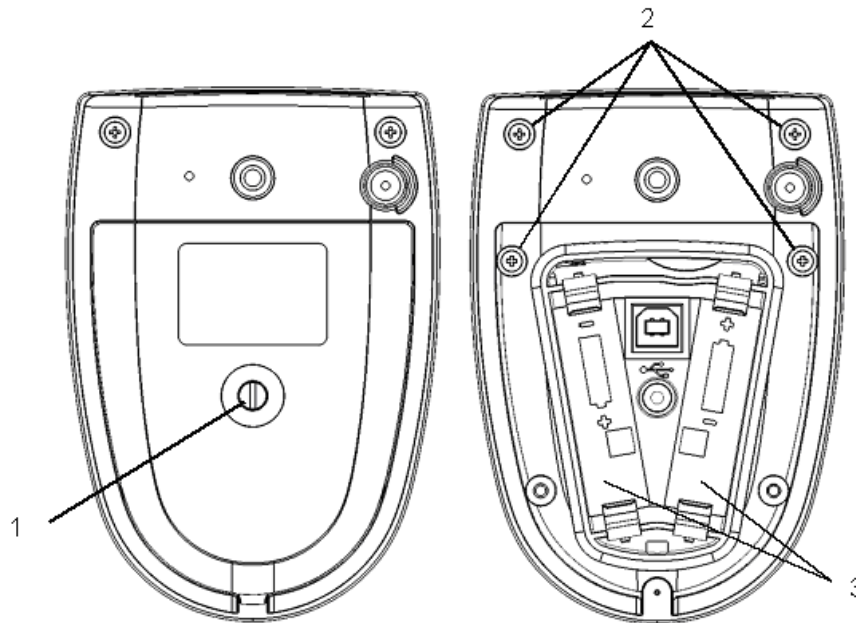

**Figure 10**      **Battery compartment**

- 1) Battery compartment access screw
- 2) Sensor compartment access screws
- 3) Battery compartments



**WARNING:** CARE SHOULD BE TAKEN WHEN INSERTING BATTERIES, PAYING PARTICULAR ATTENTION TO THE ORIENTATION OF EACH BATTERY. MARKINGS ON THE INSIDE OF THE BATTERY COMPARTMENT INDICATE THE CORRECT BATTERY ORIENTATION. INCORRECT ORIENTATION OF THE BATTERIES MAY RESULT IN DAMAGE TO THE DEVICE. BATTERIES SHOULD BE INSERTED BY HAND WITHOUT USE OF TOOLS USING REASONABLE FORCE ONLY.

## 5 Charging the ADM Aspida



**WARNING: THE FOLLOWING SAFETY WARNINGS SHOULD BE OBSERVED BEFORE ATTEMPTING TO CHARGE THE ADM ASPIDA:**

**THE ADM ASPIDA SHOULD ONLY BE CHARGED WHEN THE NIMH BATTERIES SUPPLIED WITH THE PRODUCT ARE FITTED. ATTEMPTING TO RECHARGE NON-RECHARGEABLE ALKALINE BATTERIES WILL IN MOST CASES RESULT IN AN ABORTED CHARGE, AND THIS WILL BE INDICATED BY A FLASHING  ICON ON THE DISPLAY. HOWEVER, CONNECTING THE MAINS CHARGER WHILST USING ALKALINE BATTERIES IS NOT RECOMMENDED AND MAY RESULT IN DAMAGE TO THE DEVICE.**

**THE ADM ASPIDA MAY BE USED WITH STANDARD RECHARGEABLE AA TYPE BATTERIES WHICH HAVE BEEN CHARGED USING A THIRD-PARTY CHARGING DEVICE. HOWEVER, ONLY NIMH BATTERIES PROVIDED BY ANALOX SHOULD BE USED WHEN ATTEMPTING TO CHARGE BATTERIES WITHIN THE DEVICE USING THE MAINS CHARGER.**

**DO NOT ATTEMPT TO CHARGE THE DEVICE USING A MAINS CHARGER OTHER THAN THE ONE SUPPLIED WITH THE DEVICE. USE OF AN INCORRECT MAINS CHARGER MAY DAMAGE THE DEVICE AND INVALIDATE THE WARRANTY.**











**THE BATTERY COVER SHOULD ALWAYS BE SECURELY FITTED BEFORE PERFORMING A CHARGE.**

- With the mains charger disconnected from the wall outlet, insert the power jack into the socket on the rear of the ADM Aspida device.
- Insert the mains charger into the wall outlet.
- Switch on the mains at the wall outlet.



**NOTE: THE UNIT CAN BE CHARGED WHILST SWITCHED ON OR SWITCHED OFF.**

The following lists the conditions that may be observed during a charge.

Battery icon state	Audible warning	Charge status
 >>  (animated)	None	Charging (charge setup)
 >>  >>  (animated)	None	Charging
 >>  (animated)	None	Charging (Approx. 1.5 hours remain)
	Success beep	Charge complete
 (flashing)	Fault beep	Charge fault Batteries not rechargeable
	Fault beep	No batteries

The normal charge period for a set of fully discharged batteries is approximately 4.5 hours.





**NOTE:**

**DURING CHARGING, THE DEVICE WILL WARM UP. THIS EFFECT IS NORMAL. IT IS HOWEVER SUGGESTED THAT THE DEVICE IS CHARGED INDOORS AT ROOM TEMPERATURE TO ENSURE A FULL CHARGE CYCLE COMPLETES.**

## 6 Operation

### 6.1 Button functions

The ADM Aspida has three buttons that are used as follows:

Button	Function
	<ul style="list-style-type: none"><li>• Power on/off</li><li>• Confirm</li><li>• Select button</li></ul>
	<ul style="list-style-type: none"><li>• Show device menu</li><li>• Cycle through options</li></ul>
	<ul style="list-style-type: none"><li>• Cancel</li><li>• Return to main screen</li></ul>

### 6.2 Switching the device on/off

To switch the ADM Aspida on, press the  button.

After a few seconds, the main gas display screen will be shown. If multiple usernames are registered to the device, then the username selection screen will be shown instead. See the section 'User registration' for further instructions.

On start-up, the sensors have a short warm-up period. Live gas values will not be displayed until the sensors have completed their warm-up. Typically, for oxygen, the warm-up takes 15 seconds and for carbon dioxide, the warm-up takes 30 seconds. Sensor warm-up will be shown on the display.

To switch off the device, from the main display press and hold the  button until the screen goes blank then release the button.

To return to the main display from the menu system, press and release the  button as required to exit the menus.





**NOTE: THE DEVICE CANNOT BE TURNED OFF WHEN POWERED FROM USB.**

### 6.3 User registration

The ADM Aspida allows for registration of up to two usernames. This allows users to share use of the device. On start-up, a username is selected, and all subsequent gas information is logged internally against the selected user ID. Users can be registered to a device using the ADM Aspida configuration software. See the ADM Aspida configuration software manual for instructions.

On device power up, if a single user is registered, the username will be displayed for a few seconds, after which the device will operate normally.

If 2 users are registered, both usernames will be displayed in a menu for the user to select. Pressing the  button will cycle between highlighted usernames. The  button will select the highlighted user.



**NOTE:**

**IF A USER IS NOT SELECTED WITHIN 2 MINUTES OF START-UP, A 'NO USER' ID WILL BE SELECTED AUTOMATICALLY AND THE DEVICE WILL PROCEED TO RUN NORMALLY. DURING THESE TWO MINUTES, A REMINDER BEEP WILL BE SOUNDED TO PROMPT THE USER TO SELECT AN ID.**

### 6.4 The main display

Under normal operation, gas values for each of the sensors fitted are shown in their own window along with the description of the gas type and measurement units. The current gas value for each sensor will be updated on the display once per second.



**Figure 11** *Dual sensor display (left), single sensor display (right)*

- |                                      |  |
|--------------------------------------|--|
| 1) Man-down detection enabled icon   | 6) Quiet mode enabled icon             |
| 2) Clock                             | 7) Atmospheric pressure (mbar)         |
| 3) Measured gas types (dual sensor)  | 8) Battery status icon                 |
| 4) Measured gas values (dual sensor) | 9) Measured gas type (single sensor)   |
| 5) Measured gas units (dual sensor)  | 10) Measured gas value (single sensor) |
|                                      | 11) Measured gas units (single sensor) |



**NOTE:**

**THE ADM ASPIDA DOES NOT INCLUDE A PRESSURE SENSOR, IT HAS A FIXED ATMOSPHERIC PRESSURE READING OF 1000 MBAR. THIS VALUE IS DISPLAYED AS ABOVE BUT WILL REMAIN AT 1000 MBAR.**

## 6.5 Screen saver

The screen saver function is intended to extend the battery life of an ADM Aspida and reduce screen burn-in. If the user does not operate any buttons for one minute then the screen saver, when enabled, will automatically dim the display.

Pressing any button will wake the device from screen saver mode.





If the device is connected to the charger or connected to a PC via USB, the screensaver will not be shown, but the display will still dim as normal.

During screen saver mode, gas values are still monitored as normal. Any gas alarm will wake the display from screen saver immediately and the main gas display will be shown.

It is possible to enable/disable the screen saver option via the supplied PC software.

## 6.6 Battery status

The battery status icon is shown in the top right-hand corner of the display. This icon gives a representative indication of the power remaining in the batteries. As the batteries run down from full to empty, the battery icon will be displayed in various states.

Icon	Battery status
	Battery sufficiently charged
	Battery low
 (flashing)	Battery nearly empty. Approx. 1 hour of operation remaining. A reminder beep will sound periodically.
	The device is powered from the mains charger. The icon will be shown next to the battery icon.
	The device is attached to and powered by a computer via a USB cable. The USB symbol will be shown instead of the battery icon (in addition to, if charging).



**NOTE:**

**DUE TO THE NATURE OF THE BATTERY TYPE, THE BATTERY STATUS ICON MAY TEMPORARILY INDICATE A CAPACITY HIGHER THAN THE TRUE REMAINING BATTERY CAPACITY UPON SWITCH-ON. THIS EFFECT IS USUALLY SEEN IN DEVICES WHICH HAVE BEEN SWITCHED OFF FOR AN EXTENDED PERIOD OF TIME. THE TRUE BATTERY STATUS WILL BE INDICATED WITHIN A FEW MINUTES OF POWER-UP.**

## 6.7 Menus





- 1] The device main menu can be accessed by pressing the  button. This will display a menu screen like the one shown below.









Figure 12 Typical menu



**NOTE: THE MENU ICONS DISPLAYED WILL VARY DEPENDING ON THE CONFIGURATION OF THE DEVICE AND THE SENSOR FITTED.**

- 2] Press  to cycle through the menu options and highlight the chosen option. If an arrow is present at either end of the menu, it indicates that there are more options beyond the edges of the visible menu. Advancing the menu cursor past the end of the visible menu will reveal the extra menu items.
- 3] Pressing the  button when the chosen option is highlighted will select that option.
- 4] Pressing  at any time whilst the menu is shown will return to the main gas display.

## 6.8 Common menu items

Menu Icon	Function
	<b>Information</b> – Selecting this menu item will display a screen with information related to the specific device, such as serial number and firmware version.
	<b>Back</b> – Selecting back exits the menu and returns to the main gas display.
	<b>Carbon dioxide calibration</b> – (carbon dioxide configurations only) Select this option to perform a calibration of the carbon dioxide sensor. This feature is described in further detail in the section 0.
	<b>Oxygen calibration</b> – (oxygen configurations only) Select this option to perform a calibration of the oxygen sensor. This feature is described in further detail in the section 0.
	<b>Carbon dioxide sensor information</b> – (carbon dioxide configurations only). This option displays a page which gives information about when the sensor is next due a calibration.
	<b>Oxygen sensor information</b> – (oxygen configurations only). This option displays a page which gives information about when the sensor is next due a calibration and when replacement of the sensor is due.

## 6.9 Gas alarms

The ADM Aspida has a range of configurable alarms to warn the user of potentially dangerous atmospheres. For each gas sensor fitted to the device, up to 3 configurable alarms are available. In the case of carbon dioxide, an extra time weighted average (TWA) alarm is provided. See section 6.17 for more details.

In the case of an alarm condition being detected, the horn will activate giving an audible warning to the user. At the same time, the red alarm indicators will flash.

The device also has a vibrating alert to accompany gas alarms. When an alarm is triggered the unit will vibrate (vibration limited to 10 seconds when man-down detection is enabled). The unit will not vibrate whilst connected to USB or the charger.

A gas alarm condition will also be shown on the display, giving a clear indication of the gas that has triggered the alarm. In the case of an alarm, the gas warning symbol  will appear below the gas reading which will be surrounded by a flashing border, as shown below.

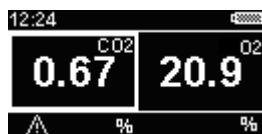

**Figure 13**      *The main gas display showing that carbon dioxide levels have triggered an alarm*

Each alarm is configurable as either high-going or low-going. In the case of a high going alarm, if the gas value exceeds the configurable set-point, the alarm will be activated. The 3 gas alarms are also ranked in order of priority, so that if a more dangerous level of gas is detected, the user is notified.

### **Example:**

Two low going alarms are normally configured for detection of low oxygen levels.

- Priority 1 alarm is configured as a low going alarm with a set-point of 18.0% or 180mBar.
- Priority 2 alarm is configured as a low going alarm with a set-point of 19.5% or 195mBar.

If using this setup, the detected level of oxygen falls below 19.5%, priority 2 alarm will be activated. The red indicators, vibration and horn will all activate, pulsing at a moderate rate, and a visual warning will be given on screen. The oxygen value will be highlighted and the gas warning symbol  shown below the reading.

If the detected oxygen level falls further so that it is below 18.0%, priority 1 alarm will be activated. This alarm is of a higher priority than the priority 2 alarm so the urgency of the alarm will be increased. The indicators, vibration and horn will begin to pulse more rapidly to indicate that the severity of the alarm has increased.

There is also normally a priority 3 alarm is configured as a high going oxygen alarm with a set-point of 23.0% or 230mBar.

## **6.10 Global alarm options**



There are three configurable options which affect all of the ADM Aspida's alarms. Muting, latching and quiet options are set using the ADM Aspida configuration software. See the ADM Aspida configuration software manual for instructions.

## **6.11 Alarm set-points**

The alarm set-points and direction can be changed using the ADM Aspida configuration software. See the ADM Aspida configuration software manual for instructions. An ADM Aspida also has the facility to change the alarm set-points on the device as per section 6.11.1





### 6.11.1 On device alarm set-points

The below procedure is the same for both the CO<sub>2</sub> and O<sub>2</sub> alarm setpoints.

- 1] Press the  button to access the device menu.
- 2] Use the  button multiple times to highlight the **Alm CO<sub>2</sub>** icon or the **Alm O<sub>2</sub>** icon (initially off the display to the right) and press .



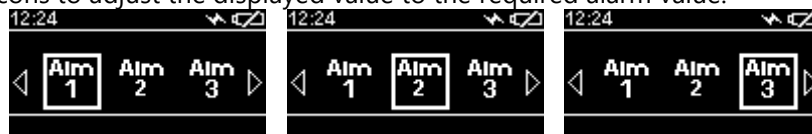

**Figure 14** Alm CO<sub>2</sub> or Alm O<sub>2</sub> selection

- 3] Using the  and  Buttons select the relevant **Alm 1**, **Alm 2** or **Alm 3** icon and then use the  and  icons to adjust the displayed value to the required alarm value.



**Figure 15** Selecting the alarm setpoint

- 4] When correctly set, confirm the alarm value using the  icon and  Button.



**Figure 16** Example CO<sub>2</sub> Alm 1 set-point



**Figure 17** Example O<sub>2</sub> Alm 1 set-point

## 6.12 Alarm latching

Sometimes it is useful for a user to be alerted to a harmful gas level, even after the level of gas has dropped to a safe level. The ADM Aspida can be configured to use latching alarms so that alarms triggered by harmful gas levels will not be missed. The latching alarms option can be enabled using the ADM Aspida configuration software.

If the device is configured to use latching alarms, then any alarm that is triggered will remain active until it is acknowledged by pressing the  button.



### Example

If a high-going alarm is activated by an increasing level of gas, the alarm will continue to sound even after the gas level has dropped below the alarm set-point. The alarm can be acknowledged by pressing the  button when the gas reading has fallen below the set-point.

In the case of multiple alarms, the highest priority alarm that was triggered will be latched. If the priority 1 alarm is latched and the gas level drops below the priority 1 set-point, pressing the  button will clear the priority 1 alarm, however, if the gas level is still sufficient to trigger the priority 2 alarm, the device will continue to alarm at a priority 2 level.

## 6.13 Alarm muting

Sometimes it is desirable to be able to mute the horn or stop the device vibrating when an alarm is triggered. The ADM Aspida provides an option to allow alarms to be muted. The mutable alarms option can be set using the ADM Aspida configuration software.

If the alarm muting option is set on the device, any active alarm can be silenced by pressing the  button whilst in an alarm state. Pressing  will deactivate the horn and the vibration. The red indicators and the on-screen warning will continue to flash until the alarm condition is cleared by safe levels of gas. In the case where a lower priority alarm has been muted and a higher priority alarm is triggered, the alarms will be un-muted.

### Example

If a priority 2 alarm is activated and muted and the detected gas level changes to activate a priority 1 alarm, the horn and vibration will re-activate to warn the user of the increased severity. A muted alarm will not be un-muted in the case where the alarm level drops to a lower priority.

## 6.14 Quiet alarms

Sometimes it is desirable to suppress the audible indication when alarm is triggered. The ADM Aspida provides an option to allow alarms to be silenced. The quiet alarms option can be set using the ADM Aspida configuration software. The display will indicate quiet mode with an icon  in the status area.

## **6.15 Data logging**

The ADM Aspida has a built-in data-logging facility which will automatically log gas readings for all fitted sensors and pressure, whenever the device is active. Readings are logged to internal memory at a rate configurable through the user software. The device can store over 7 days of continuous data. All data is logged with a date and time stamp, and where multiple users are registered with the device, each set of readings is logged against the selected user ID.

The data-log can be downloaded from the device for analysis using the ADM Aspida configuration software. See the ADM Aspida configuration software manual for instructions.

## **6.16 Panic alarm**

In cases where a worker is in distress and still conscious, it is possible to activate the ultra-loud siren manually. To activate the panic alarm, press and hold the  button for a minimum of 1 second.

## 6.17 Time-weighted average (TWA) monitoring of carbon dioxide

Carbon dioxide is toxic to the human body as concentrations increase. Short term exposure to the gas can be potentially lethal. Longer term exposure to more moderate levels of carbon dioxide can also be detrimental to health, so health and safety bodies such as UK HSE define occupational exposure levels (OEL) for the gas. These OELs provide a recommended safe exposure to carbon dioxide whilst under working conditions. The occupational exposure levels are based on a calculated time-weighted average (TWA) level of carbon dioxide in any one 24-hour period. The TWA calculation is based on average carbon dioxide levels weighted to an assumed standard 8-hour daily working shift.

The ADM Aspida has a facility which automatically calculates a TWA value on a per-user basis. When a user powers on the device and selects a user ID, the ADM Aspida begins calculating and continuously updating that user's own TWA. The device also considers any historic data from the last 24 hours which is relevant to the selected user. TWA data is logged alongside the actual gas readings in the internal data log.



**NOTE:**

**IF NO USERS IDS ARE REGISTERED TO THE DEVICE, THE TWA VALUES WILL ALL BE ATTRIBUTED TO A DEFAULT USER.**

An alarm feature is provided which will warn of a high TWA exposure to carbon dioxide. In addition to the normal 3 available gas alarms per sensor, carbon dioxide sensors have a 4<sup>th</sup> alarm (priority 4) which is triggered when the calculated TWA value exceeds the TWA set-point. This alarm is set by default to the UK HSE recommended OEL for carbon dioxide of 5000ppm (0.5%). When this alarm is triggered, the red indicators, vibration and horn warnings will activate as with other gas alarms. In the case of a TWA alarm, a TWA symbol will be shown below the carbon dioxide reading on the display, as shown below. The TWA alarm is the lowest priority alarm and as such will be over-ridden by any gas alarms triggered by a short-term increase in carbon dioxide levels.



**Figure 18** The main gas display showing that the user has exceeded their TWA exposure to carbon dioxide

As with the standard gas alarms, the TWA alarm can also be fully configured using the ADM Aspida configuration software.

## 6.18 Maintenance reminders

The ADM Aspida can track the due dates for the various maintenance tasks that are required during the products life and will display a warning symbol on the display when a maintenance task is due. Reminders will be shown for the following tasks.

Sensor calibration due (carbon dioxide and oxygen sensors)

Sensor replacement due (oxygen sensors only)

The due dates for maintenance tasks (dd/mm/yyyy) can be viewed at any time by accessing the sensor information screen for each sensor by selecting either  $O_2$  or  $CO_2$  from the main menu. An example is shown in **Figure 19**.



**Figure 19** Oxygen sensor information

## 6.19 Calibration reminders

When a sensor is due for a re-calibration, the calibration due reminder symbol (CAL) will be displayed flashing below the reading of the sensor that is due calibration, as shown in **Figure 20**. This symbol will continue to flash until a calibration has been performed.



**Figure 20** Carbon dioxide calibration due reminder

In the case of an oxygen sensor, the calibration due reminder will be cleared upon a successful calibration. In the case of a carbon dioxide sensor, the reminder will only be cleared once a zero and span calibration have been performed consecutively. See the 'Calibration' section of this manual for details of how to calibrate the sensors.

## 6.20 Sensor replacement reminders

Oxygen sensors will need to be periodically replaced as they deplete. When an oxygen sensor is due to be replaced, the replacement due reminder icon (↔) will be displayed flashing below the sensor's gas reading, as shown in Figure 12. See section 7.5 for details of how to replace the oxygen sensor. The sensor replacement reminder can only be reset by using the ADM Aspida configuration software. See the ADM Aspida configuration software manual for details of how to reset the sensor replacement reminder.

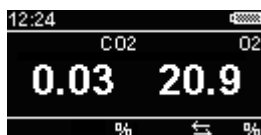



Figure 21 Oxygen replacement due reminder

## 6.21 Faults

If at any point during operation the device detects a fault, an audible alarm will be sounded, and the amber indicator will flash. A fault will also be indicated by a ⚡ symbol on the display top bar. If the fault is related to a sensor, the sensor window will show '---' and the ⚡ symbol will be shown below the sensor's gas reading window, as shown below. A fault alarm can be acknowledged by pressing the  button.

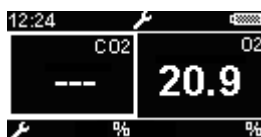







Figure 22 Display showing a carbon dioxide sensor fault



**WARNING: IF AT ANY TIME THE GREEN 'OK' INDICATOR IS NOT FLASHING AND THE AMBER 'FAULT' INDICATOR IS FLASHING THE ADM ASPIDA MUST NOT BE USED AND THE SUPPLIER SHOULD BE CONTACTED.**

## 6.22 Troubleshooting

Symptom	Possible cause	Action
Device does not switch on	No batteries, or incorrectly orientated batteries	Check that batteries are inserted correctly
Device does not switch on	Batteries are flat	Check that the batteries are inserted correctly and are rechargeable NiMH then perform a device charge.
Batteries will not charge (  shown flashing)	Batteries may not be rechargeable type	Check that the batteries fitted are the rechargeable NiMH batteries supplied with the ADM Aspida
Batteries will not charge (  shown flashing)	Aged batteries causing a charge fault	Contact supplier for information about replacing rechargeable batteries
Batteries will not charge (  shown)	No batteries fitted	Check that rechargeable batteries are fitted
Battery charge completes but battery life is short	Battery ageing reduced battery capacity	Contact supplier for information about replacing rechargeable batteries
Flashing  symbol underneath gas reading	The sensor is due a recalibration	Refer to section 0 of this manual for instructions
Flashing  symbol underneath oxygen gas reading	The oxygen sensor is due to be replaced	Refer to section 7.5 of this manual for instructions

## 7 Maintenance

### 7.1 Spares & accessories

Part number	Description
9300-1008K	Aspida download kit, comprising: 1 x software disk 1 x USB lead
9300-1009K	Wall mount clip
9300-1010	Leather belt clip with press-stud fastener
2822-0035	9V Universal Charger/PSU (With UK, Euro & US Heads)
T3672EG	Australian Plug Head for Universal PSU
P0132-401	ADM Aspida mounting brackets (Optional – to replace ties and bases)
4000-0132-0001	ADM Aspida Faceplate Kit
P0132-602	ADM Aspida fixing kit comprising: 4 x M5 cage nuts 4 x M5x25mm Pozi Pan screws
P0132-603	ADM Aspida battery backup comprising: 2 x NiMH re-chargeable batteries
PGA-401DK	Dual calibration adaptor
PGA-401SK	Single calibration adaptor
<b>CO<sub>2</sub> calibration gas kit, comprising:</b>	
Contact Analox or source locally.	20l 3% CO <sub>2</sub> in N <sub>2</sub>
Contact Analox or source locally.	20l 100% N <sub>2</sub>
Contact Analox or source locally.	Fine control valve and tubing
<b>O<sub>2</sub> calibration gas kit, comprising:</b>	
Contact Analox or source locally.	20l 21% O <sub>2</sub> in N <sub>2</sub>
Contact Analox or source locally.	20l 100% N <sub>2</sub>
Contact Analox or source locally.	Fine control valve and tubing
9100-1060RK	Replacement O <sub>2</sub> sensor and extraction kit

## 7.2 Calibration

The sensors within the ADM Aspida device should be calibrated periodically to compensate for the effect of aging. It is therefore important that the sensors are periodically re-calibrated.

The regularity of calibration depends upon the sensor.

- Carbon dioxide sensors should be calibrated every 12 months.
- Oxygen sensors should be calibrated every 3 months and when a new sensor is installed. Additionally, if the unit is dropped or accidentally immersed this can affect the oxygen sensor calibration so recalibration may be required. See section 0 below in case of accidental immersion.

Since charging the batteries causes the unit to heat up which in turn causes some variation in readings, it is inadvisable to calibrate the unit when actively charging the batteries or soon after.

## 7.3 Sensor calibration











The calibrations available on the ADM Aspida are shown in the table below. For a calibration due notification to be cleared for a sensor, the user must perform all of the calibrations available for the sensor. The ADM Aspida requires both a low and high oxygen calibration to be performed using calibration gas to clear a calibration due notification.

Aspida type	Carbon dioxide calibrations available on device	Oxygen calibrations available on device
ADM Aspida	High and low	High and low



**WARNING: ALWAYS ENSURE THAT THE CALIBRATION GAS IS SUITABLE FOR USE. INACCURACY IN CALIBRATION OF THE UNIT WILL CAUSE AN INACCURACY OF THE DISPLAYED AND ALARMED VALUES. CERTIFIED CALIBRATION GAS SHOULD ALWAYS BE USED WHEN CALIBRATING CO<sub>2</sub> SENSORS.**

### 7.3.1 Perform an O<sub>2</sub> sensor calibration:

- 1] Press the  button to access the device menu.
- 2] Use the  button multiple times to highlight the  icon (initially off the display to the right) and press .
- 3] Using the  and  Buttons and  and , adjust the displayed value to the correct calibration value corresponding to the calibration gas used.
- 4] When correctly set, confirm the calibration using the  icon and  button.



**Figure 23** Calibration data entry screen (ready to confirm calibration)

- 5] The unit will now sample the ambient air for 30 seconds to detect a stable gas reading. The progress of the sampling will be displayed on screen as shown below.



**Figure 24** Calibration progress

- 6] When the sampling process has complete, an audible alert will be given, and a calibration confirmation screen will be shown as below.



**Figure 25** Calibration failed











**Figure 26** Calibration passed

- 7] If the calibration passed, then the tick icon will be shown. The new calibration information will then be stored to the device memory and the device is ready for use. Press the  button to confirm the operation and return to the main screen.

- 8] If a stable oxygen reading cannot be detected, then the confirmation screen will show a cross icon. Press the  button to acknowledge the failed calibration. A failed calibration will leave the previous gas calibration unchanged. To attempt the calibration again repeat steps 3 – 8.
- 9] Once calibrated successfully, the calibration due date for the sensor will be reset.

### 7.3.2 Perform a CO<sub>2</sub> sensor calibration

The below procedure is the same for both the CO<sub>2</sub> LO and CO<sub>2</sub> HI calibrations.

- 1] Press the  button to access the device menu.
- 2] Use the  button multiple times to highlight the **CAL CO<sub>2</sub>** icon (initially off the display to the right) and press .
- 3] Using the  and  buttons select the relevant **CAL LO** or **CAL HI** icon and then use the  and  icons to adjust the displayed value to the correct calibration value corresponding to the calibration gas used.
- 4] When correctly set, confirm the calibration using the  icon and  button.



**Figure 27** CO<sub>2</sub> LO calibration data entry screen (ready to confirm calibration)



**Figure 28** CO<sub>2</sub> HI calibration data entry screen (ready to confirm calibration)

- 5] The unit will now sample the ambient air for 30 seconds to detect a stable gas reading. The progress of the sampling will be displayed on screen as shown below.



**Figure 29** Calibration progress

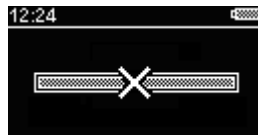

- 6] When the sampling process has complete, an audible alert will be given, and a calibration confirmation screen will be shown as below.



**Figure 30**      **Calibration failed**



**Figure 31**      **Calibration passed**

- 7] If the calibration passed, then the tick icon will be shown. The new calibration information will then be stored to the device memory and the device is ready for use. Press the  button to confirm the operation and return to the main screen.
- 8] If a stable carbon dioxide reading cannot be detected, then the confirmation screen will show a cross icon. Press the  button to acknowledge the failed calibration. A failed calibration will leave the previous gas calibration unchanged. To attempt the calibration again repeat steps 3 – 8.

Once calibrated successfully, the calibration due date for the sensor will be reset.

## 7.4 CO<sub>2</sub> sensor replacement



**CAUTION:** ANALOX IS THE ONLY COMPANY APPROVED TO SERVICE AND/OR REPLACE THE CO<sub>2</sub> SENSOR. ANY ATTEMPT TO SERVICE, REPAIR OR REPLACE THE CO<sub>2</sub> SENSOR BY ANY OTHER PARTY WILL VOID ANY WARRANTY.

## 7.5 Oxygen sensor replacement

The oxygen sensor used in oxygen versions of the ADM Aspida is an electrochemical cell, and hence the sensor output will deplete over time, the expected life of the sensor is 1 year (with a 6-month warranty), depending on usage. After a 1-year period of service, or when the sensor has depleted, the oxygen sensor should be replaced with a fresh sensor. (Contact supplier for a replacement sensor).



**WARNING:** BEFORE REPLACING THE SENSOR, ENSURE THE DEVICE IS SWITCHED OFF (DISCONNECT FROM ANY USB CABLE OR CHARGER). OPEN THE BATTERY COMPARTMENT AND REMOVE THE BATTERIES FROM THE DEVICE.



**WARNING:** THE SENSOR IN THE ADM ASPIDA IS AN ELECTROCHEMICAL DEVICE AND CONTAINS A CAUSTIC ELECTROLYTE. THE SENSORS ARE THEMSELVES SEALED AND DO NOT UNDER NORMAL CIRCUMSTANCES PRESENT A HEALTH HAZARD HOWEVER IF LEAKAGE OF THE POTASSIUM HYDROXIDE ELECTROLYTE HAS OCCURRED USE RUBBER GLOVES AND WEAR CHEMICAL SPLASH GOGGLES TO HANDLE AND CLEAN UP AND DO NOT ALLOW THE ELECTROLYTE ONTO ANY PART OF YOUR BODY OR CLOTHING. RINSE CONTAMINATED SURFACES WITH WATER. IN THE EVENT THAT YOU DO COME INTO CONTACT WITH THE ELECTROLYTE WASH THE CONTAMINATED PART WITH COPIOUS AMOUNTS OF WATER.

For ADM Aspida's with the faceplate fitted section 4.3 should be followed to gain access to the instrument.

To replace the oxygen sensor:

- 1] Remove the top 4 screws from the device using a cross-head screwdriver as shown in Figure 32. Retain the screws along with the sealing washers.



**Figure 32**      **Remove the sensor cap screws**

- 2] Gently remove the sensor cap as shown in Figure 33.



**Figure 33**      **Remove the sensor cap**



**WARNING: DO NOT TOUCH THE INSIDE OF THE (INSTRUMENT OTHER THAN AS NOTED IN THESE INSTRUCTIONS) WITHOUT APPROPRIATE ANTI-STATIC PRECAUTIONS.**

- 3] Locate the alignment rib on the sensor extraction tool as shown in Figure 18.



**Figure 34**      **Locate the alignment rib**

- 4] Gently slide the sensor extraction tool over the oxygen sensor (right hand sensor) being careful not to cause damage to the carbon dioxide sensor (left hand sensor, if fitted). Ensure that the alignment rib on the extraction tool lines up with the alignment marker on the ADM Aspida case as shown in Figure 35.



**Figure 35**      **Align the extraction tool**

- 5] The extraction tool should now be positioned as shown in Figure 36.



**Figure 36**      **Correct extraction tool position**

- 6] Squeeze the grip on the extraction tool to achieve a firm hold on the oxygen sensor as shown in Figure 37.



**Figure 37**      **Squeeze the extraction tool**

- 7] Lift the extraction tool vertically away from the device and the oxygen sensor should lift out of its socket as shown in Figure 38.



**Figure 38**      **Removing the oxygen sensor**

- 8] Remove the old sensor from the extraction tool by gently pushing the sensor from the wide, top end of the extraction tool, whilst not squeezing the grip.



**THE SENSOR CONTAINS LEAD AND ACCORDING TO WEEE REGULATION MUST NOT BE PLACED IN HOUSEHOLD WASTE BINS. PLEASE CHECK LOCAL REGULATIONS FOR INFORMATION ON THE DISPOSAL OF ELECTRONIC PRODUCTS IN YOUR AREA.**

- 9] Remove the new sensor from its packaging. Oxygen sensors are supplied in sealed bags. Before the bag is opened check that the sensor has not leaked – if it has, then please refer to the safety information at the start of this section.



**Figure 39**      **Insert the new sensor into the extraction tool**

- 10] Insert the new sensor as show in Figure 39, ensuring that the two pins of the new sensor are away from, but align with the extraction tool alignment rib, as shown in Figure 40.



**Figure 40**      *Align the new sensor in the extraction tool*

- 11] Align the extraction tool rib with the ADM Aspida case alignment mark as in step 4 as shown in Figure 41.



**Figure 41**      *Align the new sensor with the ADM Aspida device*

- 12] Push the tool and sensor gently downwards into the case until the sensor locates firmly within its socket.
- 13] Hold the top ring of the extraction tool gently, without squeezing the grip (Figure 42) and lift the tool vertically upwards to remove the extraction tool whilst leaving the new sensor in place. (A gentle twisting of the tool may help to separate the tool from the sensor).



**Figure 42**      **Remove the extraction tool**

- 14] Replace the sensor cap ensuring that the oxygen cell is centrally sited in the gas port with the white gasket visible around the whole of the gas port. If misaligned, remove the sensor cap, and adjust the oxygen cell position using the extraction tool. Then refit the cap and recheck the alignment.

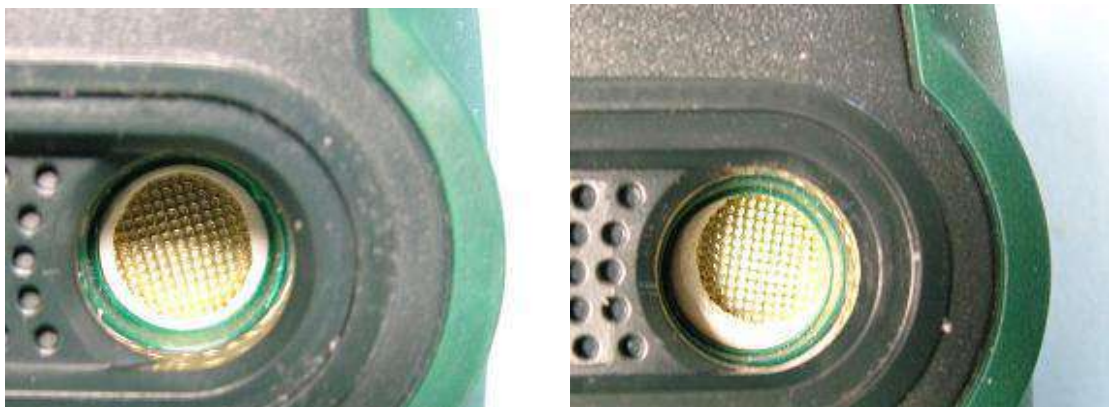

**Figure 43**      **Centralised and misaligned sensors**

- 15] Holding the sensor cap in position, turn the unit over and fit the 4 crosshead screws (including washers) into the rear of the case as shown in. Figure 28.



**Figure 44** Replace the sensor cap and secure the screws



**WARNING:** ANY NEW SENSOR FITTED TO A DEVICE WILL TAKE TIME TO SETTLE TO A STABLE READING. FOR THIS REASON, ONCE THE SENSOR HAS BEEN FITTED, THE DEVICE SHOULD BE LEFT UN-POWERED FOR AT LEAST 2 HOURS BEFORE ATTEMPTING TO POWER-UP AND CALIBRATE.

- 16] Once the sensor has been allowed to settle, replace the batteries and fit the battery cover.

- 17] Power the device and allow the sensor(s) to warm up. The new oxygen sensor will require calibration and may be showing a fault due to an over-range reading (this is possible for a new sensor). To calibrate the oxygen sensor, follow the instructions in the section 0.



**NOTE:** THE OXYGEN SENSOR MAY REQUIRE FURTHER FRESH AIR CALIBRATIONS AS THE SENSOR CONTINUES TO SETTLE. THE OXYGEN READING SHOULD BE CHECKED FREQUENTLY IN FRESH AIR DURING THE FIRST FEW HOURS OF OPERATION WITH A NEW OXYGEN SENSOR.

To ensure the sensor replacement reminder (↔ icon) occurs at the correct time for the new sensor, the reminder should be reset using the ADM Aspida configuration software. See the ADM Aspida software configuration manual for instructions.

## **7.6      Cleaning**

The ADM Aspida units should be cleaned using a damp cloth only. Abrasive or solvent products should not be used.

The only exception to this is if the unit has been accidentally immersed in dirty or salt water. In this situation only, the gas sensing ports should be rinsed with a gentle flow of clean water before leaving the unit to dry, to ensure the pores of the membranes over the sensors are not blocked by dirt or salt. The unit should be turned off after accidental immersion and not turned on again until it has completely dried. After accidental immersion (and rinsing if necessary), excess water should be shaken from the unit then the unit must be allowed to air-dry completely before using.

This may take a few hours in cool or damp conditions, during which time unit should be left turned off. If the unit is turned on whilst the membrane is damp, the reading will be low (due to excess water vapour) often enough to cause an alarm and will also drift as the water evaporates. If the unit is recalibrated whilst the membrane is still damp, this drift will continue so invalidating the calibration. For this reason, after accidental immersion the unit should be left in a dry environment to completely dry before subsequent use.

## 8 Specifications

System specification	
Operating temperature	0 to 50°C
Operating pressure	Atmospheric pressure
Humidity range	0 to 99 % RH
Display	High-visibility, Organic Light Emitting Diode (OLED) display
Alarm horn	95dB @ 30cm (110dB – man-down alarm)
LED indicators	1 x Green – OK 1 x Amber – Fault 3 x Red – Alarm
Internal data log	1 log every 30 seconds for at least 7 days of continuous use
Batteries	2 x NiMH 2100mAh AA batteries (Or suitable AA type batteries)
Battery discharge time	12 hours under normal operation (passive atmospheric monitoring, minimal user interaction, no alarms)
Battery lifespan	2 years
Battery charge time	4.5 hours (from flat)
Charger power supply rating	9v DC to 0.55A DC jack 5.5x12.0x2.1mm centre +ve
Calibration adapter max flow	0.5 l/min
EMC performance	Portable unit fully satisfies MIL STD 461F Charger compliant @ 14cm for emissions RE101 2004/108/EC

Carbon dioxide sensor (where fitted)	
Sensor type	Analox infra-red MIR
Range	0.01 to 50.00 mbar ppCO <sub>2</sub> (0.01 to 5.00% at 1000mbara)
Response time	T90 < 60 seconds
Sensor life span	5 years
Accuracy (at standard temperature and pressure):	±(1% of full scale+ 2% of reading)

<b>Oxygen sensor (where fitted)</b>	
<b>Sensor type</b>	Electrochemical
<b>Range</b>	0.1 to 2000.0 mbar ppO <sub>2</sub> (0.1 to 100.0% O <sub>2</sub> at 1000mbara)
<b>Response time</b>	T90 < 30 seconds
<b>Sensor life span</b>	1 year (expected)
<b>Accuracy (at standard temperature and pressure):</b>	±1% of full scale

## **9 Warranty information**

We provide the following Warranties for the ADM Aspida and associated accessories

- A 2-year electronics warranty.
- A 6-month oxygen sensor warranty.
- A 5-year carbon dioxide sensor warranty

In all cases the warranty period runs from the date of our invoice.

We warrant that the equipment will be free from defects in workmanship and materials.

The warranty does not extend to and we will not be liable for defects caused by the effects of normal wear and tear, erosion, corrosion, fire, explosion, misuse, use in any context or application for which the equipment is not designed or recommended, or unauthorised modification.

Following a valid warranty claim in accordance with the above, the equipment, upon return to us, would be repaired or replaced without cost or charge but in our discretion we may elect instead to provide to you whichever is the lesser of the cost of replacement or a refund of net purchase price paid as per our Invoice on initial purchase from us. We shall have no liability for losses, damages, costs or delays whatsoever. We shall have no liability for any incidental or consequential losses or damages. All express or implied warranties as to satisfactory or merchantable quality, fitness for a particular or general purpose or otherwise are excluded and no such Warranties are made or provided, save as set out in this clause.

To effectively notify a warranty claim, the claim with all relevant information and documentation should be sent in writing to:

Analox Ltd  
15 Ellerbeck Court  
Stokesley Business Park  
Stokesley  
North Yorkshire  
TS9 5PT

Or by e-mail to: [info@analox.net](mailto:info@analox.net)  
Or by Fax to: +44 1642 713900

We reserve the right to require from you proof of dispatch to us of the notification of warranty claim by any of the above alternative means.

The equipment should not be sent to us without our prior written authority. All shipping and Insurance costs of returned equipment are to be borne by you and at your risk. All returned items must be properly and sufficiently packed.

## **10 Disposal**

### **10.1 WEEE statement**



According to WEEE regulation this electronic product cannot be placed in household, waste bins. Please check local regulations for information on the disposal of electronic products in your area.

### **10.2 Oxygen sensor disposal**

The oxygen sensor used contains toxic compounds irrespective of physical condition. It should be disposed of according to local waste management requirements and environmental legislation. It should not be burnt since it may evolve toxic fumes.

## 11 UK Declaration of Conformity

### UK Declaration of Conformity

Declaration number: PSA-C003-03

Manufacturer's name: Analox Limited

Manufacturer's address: 15 Ellerbeck Court  
Stokesley Business Park  
Stokesley  
North Yorkshire  
TS9 5PT

It is declared that the following product:

Product name: Sub Aspida  
ADM Aspida

Product code: SAxxxxxxxxxx  
ADMxxxxxxxxxx

Conforms to all applicable requirements of: BS EN 50270:2015 (Type 1)  
BS EN 61000-6-1:2007  
BS EN 61000-6-3:2007+A1:2011  
BS EN/IEC 61010-1:2010  
BS EN 60529 IP6X

For SACCAAAX02A:  
Partial (DRE01.B & DCS10.B)  
compliance to Defence Standard 59-  
411 Part 3 Issue 3:2019

- Complies with the Electromagnetic Compatibility Regulations 2016
- The Electrical Equipment (Safety) Regulations 2016
- Complies with the requirements of UK RoHS Directive 2015/863
- Complies with the requirements of WEEE Regulations 2013

The above product is UKCA-marked and satisfies the relevant legislative requirements of the UK



Signed on behalf of: Analox Limited

Date: 23<sup>rd</sup> July 2024

Signed: 

Name: Paul Branton  
Position: Technical Director

## 12 Declaration of conformity

### Declaration of conformity

Declaration number: PSA-903-04

Manufacturer's name: Analox Limited

Manufacturer's address: 15 Ellerbeck Court  
Stokesley Business Park  
Stokesley  
North Yorkshire  
TS9 5PT

It is declared that the following product:

Product name: Sub Aspida  
ADM Aspida

Product code: SAxxxxxxxxxx  
ADMxxxxxxxxxx

Conforms to all applicable requirements of: BS EN 50270:2015 (Type 1)  
BS EN 61000-6-1:2007  
BS EN 61000-6-3:2007+A1:2011  
IEC/EN 61010-1:2010  
BS EN 60529 IP6X  
ANSI C63.4:2003  
AS/NZS CISPR 22:2006  
MIL STD 461F

For SACCAAX02A:  
Partial (DRE01.B & DCS10.B)  
compliance to Defence Standard 59-  
411 Part 3 Issue 3:2019

- Complies with the requirements of the EMC Directive 2014/30/EU
- Complies with the requirements of the Low Voltage Directive 2014/35/EU, as amended
- Complies with the requirements of the RoHS Directive 2015/863
- Complies with the requirements of the WEEE Directive 2012/19/EU

CE The above product is CE-marked and satisfies the relevant legislative requirements of the European Economic Area (EEA)



FCC The above product is approved by FCC to class B levels according to title 47 of the Code of Federal Regulations (CFR) part 15 (47CFR15):2008



C-Tick The above product is C Tick compliant for sale in Australia and New Zealand



Signed on behalf of: Analox Limited

Date: 23<sup>rd</sup> July 2024

Signed:

Name: Paul Branton  
Position: Technical Director