



Ax60+ Multi-Gas

Service Manual

Commercial in Confidence

UK Office
15 Ellerbeck Court,
Stokesley Business Park,
North Yorkshire, TS9 5PT, UK

US Office
15121 Graham Street #B106,
Huntington Beach, California,
92649

UK / Global
info@analoxgroup.com
+44 (0)1642 711 400

US Office
ussales@analox.biz
(714) 891 4478
Toll Free: (877) 723 3247

Contents



1	Introduction	5
1.1	Warnings, Cautions and Notes	5
1.2	Safety information	5
1.3	Other information	5
1.4	Alarm terminology (CO ₂) – Standard sensors	6
1.5	Alarm terminology (CO ₂) – US IFC sensors	6
1.6	Alarm terminology (O ₂)	7
1.7	Alarm terminology (CO)	7
2	Configuring sensors	8
2.1	Hardware setting	8
3	Software Overview	9
3.1	Powering up	9
4	Menu options	12
4.1	Read-only menus	13
4.2	List Alarm descriptions (Displayed as List Alm desc)	17
4.3	Testing relays (Displayed as Test relays)	19
5	Calibrating Ax60+ sensors	20
5.1	Sensor calibration proof test	20
5.2	Sensor calibration adjustment	21
5.3	Zero calibration adjustment on device	26
6	Calibrating Ax60+ Kiosk sensors	28
6.1	CO ₂ sensor calibration proof test	28
6.2	CO ₂ sensor calibration adjustment	29
6.3	Zero calibration adjustment on device	34
7	Electrochemical sensor replacement	36
7.1	Replacing a standard O ₂ sensor	36
7.2	Replacing a SAFE-OX O ₂ cell	36
7.3	Replacing a CO cell	38
8	Central Configuration (Displayed as Central Config)	40
8.1	Attached snrs	40
8.2	Sensor Display Option (Displayed as Snr Display Opt)	41
8.3	Set Evacuation	42
8.4	Relay configuration	43
8.5	Set elevation level	49
9	Sensor Configuration (Displayed as Sensor Config)	50
9.1	Enable alarms	50
9.2	Enable Evacuation (Displayed as Enable Evac)	51
9.3	Alarm Direction	52
9.4	Enable Sounder	53
9.5	Enable Strobe	54
9.6	Alarms Latching/Non Latching (Displayed as Alarms Latching)	55
9.7	Alarm set-points (Displayed as Alrm set-pnts)	56
10	Ax60+ Kiosk Option	58
11	Fault finding	59

11.1	Fault codes.....	59
11.2	Data Output Module fault indication.....	60
12	Appendix A – Default Central Unit configuration settings	61
13	Appendix B – Default CO₂ sensor configuration settings	62
14	Appendix C – US IFC CO₂ sensor configuration settings	63
15	Appendix D – Default Kiosk CO₂ sensor configuration settings.....	64
16	Appendix E – US IFC Kiosk CO₂ sensor configuration settings	65
17	Appendix F – Default O₂ sensor configuration settings	66
18	Appendix G – US IFC O₂ sensor configuration settings	67
19	Appendix H – Default CO sensor configuration settings	68
20	Appendix I – Data Output Module MODBUS detail.....	69
20.1	MODBUS communications protocol	69
20.2	MODBUS register map.....	70
20.3	Changing DOM Node Addresses	72
21	Appendix J - Sensor characteristics and helium effect.....	73





1 Introduction

This Service Manual explains how to service and calibrate the Ax60+. It is intended for system installers and service engineers. For information on installation and operation, refer to the Ax60+ User Manual P0159-800, downloadable from [Analox Ltd.](#)

1.1 Warnings, Cautions and Notes

-  **WARNINGS ARE USED IN THIS MANUAL TO INDICATE POTENTIALLY HAZARDOUS SITUATIONS WHICH COULD RESULT IN SERIOUS INJURY OR DEATH.**
-  **CAUTIONS ARE USED IN THIS MANUAL TO INDICATE POTENTIALLY HAZARDOUS SITUATIONS WHICH COULD RESULT IN EQUIPMENT DAMAGE OR LOSS OF DATA.**
-  **NOTES ARE USED IN THIS MANUAL TO INDICATE SUPPLEMENTARY INFORMATION THAT IS NOT HAZARD RELATED.**

1.2 Safety information

-  **WARNING: READ THE SAFETY INFORMATION IN THIS MANUAL BEFORE SERVICING THE AX60+.**
-  **WARNING: DO NOT TEST THE ALARM WHEN IT IS CLOSE TO THE EARS. IT HAS A HIGH VOLUME SOUNDER WITH A SOUND LEVEL OF 88 DECIBELS AT A DISTANCE OF 3 METRES.**
-  **WARNING: DO NOT TEST THE ALARM WHEN IT IS CLOSE TO THE EYES. IT HAS A HIGH VISIBILITY STROBE LIGHT WITH A LUMINOUS INTENSITY OF 100 CANDELA.**
-  **WARNING: DO NOT OPEN THE CENTRAL DISPLAY, SENSORS OR ALARMS IF THEY ARE CONNECTED TO THE POWER SUPPLY. FIRST DISCONNECT AND ISOLATE THEM FROM LIVE HAZARDOUS VOLTAGE.**

1.3 Other information

-  **NOTE: THE DATA OUTPUT MODULE DOES NOT REQUIRE ANY ON-SITE SERVICING, HOWEVER, THE DATA OUTPUT MODULE DOES CHECK FOR A NUMBER OF FAULT CONDITIONS, SEE SECTION 11.2 FOR DETAILS ON FAULT INDICATIONS**

1.4 Alarm terminology (CO₂) – Standard sensors

Alarms will display in priority order, in the order of AL4 to TWA

Display name for users	Alarm description	Identification by software	Default setpoint	Notes
TWA	Time weighted average over 8 hours	Alarm 1 or A1	0.5% CO ₂	Fixed alarm. At present it is not possible to change a TWA alarm set-point.
AL1	High alarm	Alarm 2 or A2	1.5% CO ₂	This alarm must be set lower than Alarm 3 (it may be set to 0.5% to give a pre-alarm condition).
CO2	High-high alarm	Alarm 3 or A3	3.0% CO ₂	This alarm must be set higher than Alarm 2.
AL4	High-high alarm	Alarm 4 or A4	3.5% CO ₂	Alarm is disabled by default.

- The time-weighted average alarm is displayed to users as 'TWA' and identified by the software as 'A1' or 'Alarm 1' and is announced by the Central Display only.
- The high alarm is displayed to users as 'AL1' and identified by the software as 'A2' or 'Alarm 2' and triggers the Alarm strobe once every 2 seconds, sounder is disabled by default, but if enabled by the user it will also sound once every 2 seconds.
- The high-high alarm is displayed to users as 'CO2' and identified by the software as 'A3' or 'Alarm 3' and triggers the Alarm strobe/sounder once every second.
- The fourth alarm level 'AL4' is disabled by default; this is identified by the software as 'A4' or 'Alarm 4'. If enabled the Alarm strobe and sounder would trigger once every second.

1.5 Alarm terminology (CO₂) – US IFC sensors

Alarms will display in priority order, in the order of AL4 to TWA

Display name for users	Alarm description	Identification by software	Default setpoint	Notes
TWA	Time weighted average over 8 hours	Alarm 1 or A1	0.5% CO ₂	Fixed alarm. At present it is not possible to change a TWA alarm set-point.
AL1	Low level pre-alarm	Alarm 2 or A2	0.5% CO ₂	This alarm must be set lower than Alarm 3
AL2	Low alarm	Alarm 3 or A3	1.5% CO ₂	This alarm must be set higher than Alarm 2.
AL3	High alarm	Alarm 4 or A4	3.0% CO ₂	This alarm must be set higher than Alarm 3.

- The time-weighted average alarm is displayed to users as 'TWA' and identified by the software as 'A1' or 'Alarm 1' and is announced by the Central Display only.
- The Low level pre-alarm alarm is displayed to users as 'AL1' and identified by the software as 'A2' or 'Alarm 2' and triggers the Alarm strobe once every 2 seconds, sounder would trigger once every 2 seconds.
- The low alarm is displayed to users as 'AL2' and identified by the software as 'A3' or 'Alarm 3' and triggers the Alarm strobe once every second, sounder would trigger once every 2 seconds.
- The high alarm is displayed to users as 'AL3' and identified by the software as 'A4' or 'Alarm 4' and triggers the Alarm strobe/sounder once every second.

1.6 Alarm terminology (O₂)

Alarms will display in priority order, in the order of AL4 to AL1

Display name for users	Alarm description	Identification by software	Default setpoint	Notes
AL1	Low alarm	Alarm 1 or A1	19.5% O ₂	Alarm is disabled by default.
AL2	Low alarm	Alarm 2 or A2	19.5% O ₂	This alarm must be set lower than Alarm 3.
AL3	High-high alarm	Alarm 3 or A3	23.0% O ₂	This alarm must be set higher than Alarm 2.
AL4	Low-low alarm	Alarm 4 or A4	18.0% O ₂	This alarm must be set lower than Alarm 2.

- The first low or high alarm 'AL1'/'AL1' is disabled by default; this is identified by the software as 'A1' or 'Alarm 1'. If enabled the Alarm strobe and sounder would trigger once every 2 seconds.
- The low-level alarm is displayed to users as 'AL2' and identified by the software as 'A2' or 'Alarm 2' and triggers the Alarm strobe once every 2 seconds, sounder is disabled by default, but if enabled by the user it will also sound once every 2 seconds.
- The high-high alarm is displayed to users as 'AL3' and identified by the software as 'A3' or 'Alarm 3' and triggers the Alarm strobe/sounder once every second.
- The low-low alarm is displayed to users as 'AL4' and identified by the software as 'A4' or 'Alarm 4' and triggers the Alarm strobe/sounder once every second.

1.7 Alarm terminology (CO)

Alarms will display in priority order, in the order of AL3 to AL1 (TWA is disabled by default)

Display name for users	Alarm description	Identification by software	Default setpoint	Notes
TWA	Disabled			
AL1	Low level pre-alarm	Alarm 2 or A2	3ppm	This alarm must be set lower than Alarm 3
AL2	Low alarm	Alarm 3 or A3	5ppm	This alarm must be set higher than Alarm 2.
AL3	High alarm	Alarm 4 or A4	10ppm	This alarm must be set higher than Alarm 3.

- The time-weighted average alarm is disabled by default.
- The Low level pre-alarm alarm is displayed to users as 'AL1' and identified by the software as 'A2' or 'Alarm 2' and triggers the Alarm strobe once every 2 seconds, sounder would trigger once every 2 seconds.
- The low alarm is displayed to users as 'AL2' and identified by the software as 'A3' or 'Alarm 3' and triggers the Alarm strobe once every second, sounder would trigger once every 2 seconds.
- The high alarm is displayed to users as 'AL3' and identified by the software as 'A4' or 'Alarm 4' and triggers the Alarm strobe/sounder once every second.

2 Configuring sensors

2.1 Hardware setting

In a standard Ax60+ system (not including the Kiosk option) each sensor must have its jumper link set to a different location e.g. Sensor 1=location 1; Sensor 2=location 2.

The Sensor has a hardware setting that is factory configured for a system with only one Sensor. If a system includes two, three, or four Sensors then the hardware must be reconfigured by moving a jumper link () in each Sensor installed in the system.

⚠ WARNING: DISCONNECT AND ISOLATE THE AX60+ SYSTEM FROM THE MAINS POWER SUPPLY BEFORE OPENING THE CO₂ SENSOR ENCLOSURES.

To access the jumper link, open the Sensor enclosure. The printed circuit board (PCB) has a SENSOR LOCATION selector with one link, factory installed in LOCATION 1.

The image to the right shows the jumper link in position 1 (Factory default).

For a system with only **one Sensor**, the jumper link should be retained in LOCATION 1.

For a system with **two Sensors**, the first Sensor's jumper link should be in LOCATION 1 and the second Sensor's link in LOCATION 2.

For a system with **three Sensors**, the first Sensor's link should be in LOCATION 1, the second Sensor's link in LOCATION 2 and the third Sensor's link should be in LOCATION 3.

For a system with **four Sensors**, the first Sensor's jumper link should be in LOCATION 1, the second Sensor's link in LOCATION 2, the third Sensor's link in LOCATION 3 and the fourth Sensor's link should be in LOCATION 4.









3 Software Overview

NOTE: THIS SECTION SPECIFICALLY RELATES TO THE AX60+ STANDARD OPTIONS, HW AND QC. HOWEVER, A CENTRAL DISPLAY CAN BE TEMPORARILY CONNECTED TO THE AX60+ KIOSK SENSOR TO ENABLE A SERVICE ENGINEER TO RECONFIGURE THE SYSTEM (SEE SECTION 10).

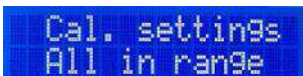
3.1 Powering up

When you power up the Ax60+, the software performs an automatic power-on-self-test (POST) which takes about 30 seconds. The results are shown on the Central Display.

Operator input	Software response	Central Display text	Optional text / notes
Switch on power supply to Ax60+	Displays vendor name (Default is Analox Ltd)		Vendor name may vary, depending on contract
		▼	
No further operator input is required. The POST is an automatic process	Performs a checksum configuration check		
		▼	
	Performs a software validation check		
		▼	
	Checks the Sensor(s) have been calibrated		
		▼	No sensors are configured
	Confirms top line of LCD OK, no pixels are missing		
		▼	
	Confirms bottom line of LCD OK, no pixels missing		
		▼	
	Confirms buzzer is off and green LED switches on		
		▼	

Operator input	Software response	Central Display text	Optional text / notes
----------------	-------------------	----------------------	-----------------------

Confirms green LED is off and yellow switches on

```
Green LED off ?
Yellow LED on ?
```



Confirms yellow LED is off and red switches on

```
Yellow LED off ?
Red LED on ?
```



Confirms red LED is off and buzzer switches on

```
Red LED off ?
Buzzer is on ?
```



Displays current software. Buzzer switches off

```
Software version
v1.0.0
```



Displays unique serial number of the unit

```
Serial number:
0000000
```



Wait for Sensors to warm up...

```
>OK OK --- ---
1: Warm-up
```

This screen may display for a few seconds to show Sensor warm-up status. It is for information only. It requires no operator input



⚠ CAUTION: EACH SENSOR MUST HAVE ITS JUMPER SET TO A DIFFERENT LOCATION (E.G. SENSOR 1 = LOCATION 1; SENSOR 2 = LOCATION 2), OTHERWISE THE CENTRAL DISPLAY WILL ANNOUNCE A FAULT.REFER TO SECTION 2 FOR JUMPER SETTINGS INFORMATION.



Wait for system status screen...

Displays system status screen. Each Sensor is represented by 'OK' in the top line. For example, a system with two CO₂ Sensors displays >OK OK. The '>' character identifies

```
>OK OK --- ---
1: 450 PPM
```

In this example - The CO₂ concentration is by default displayed in ppm (parts per million). The example shown here displays 450 PPM, which is equal to 0.045%.

Operator input	Software response	Central Display text	Optional text / notes
----------------	-------------------	----------------------	-----------------------

which Sensor is highlighted
(Sensor 1 is highlighted by default)

NOTE: THE SYSTEM STATUS SCREEN DISPLAYS UP TO FOUR SENSORS. A SPARE SENSOR LOCATION DISPLAYS AS: '- - -'

The bottom line displays the concentration of measured gas at the Sensor



Press Cycle

Displays Sensor 2 details (if installed) and the current level of measured gas

```
OK >--- --- ---
2: Not installed
```

In this example, Sensor 2 is not installed



Press Cycle

Displays Sensor 3 details (if installed) and the current level of measured gas

```
OK --->--- ---
3: Not installed
```

In this example, Sensor 3 is not installed



Press Cycle

Displays Sensor 4 details (if installed) and the current level of measured gas

```
OK --- --->---
4: Not installed
```

In this example, Sensor 4 is not installed



Press Cycle

Redisplays the system status screen

```
>OK OK --- ---
1: 450 PPM
```

4 Menu options

To display the Top-level Menu options, press and hold **Cancel + Cycle** for at least 6 seconds.

Press and hold down  +  for six seconds to enter the Top-level Menu:

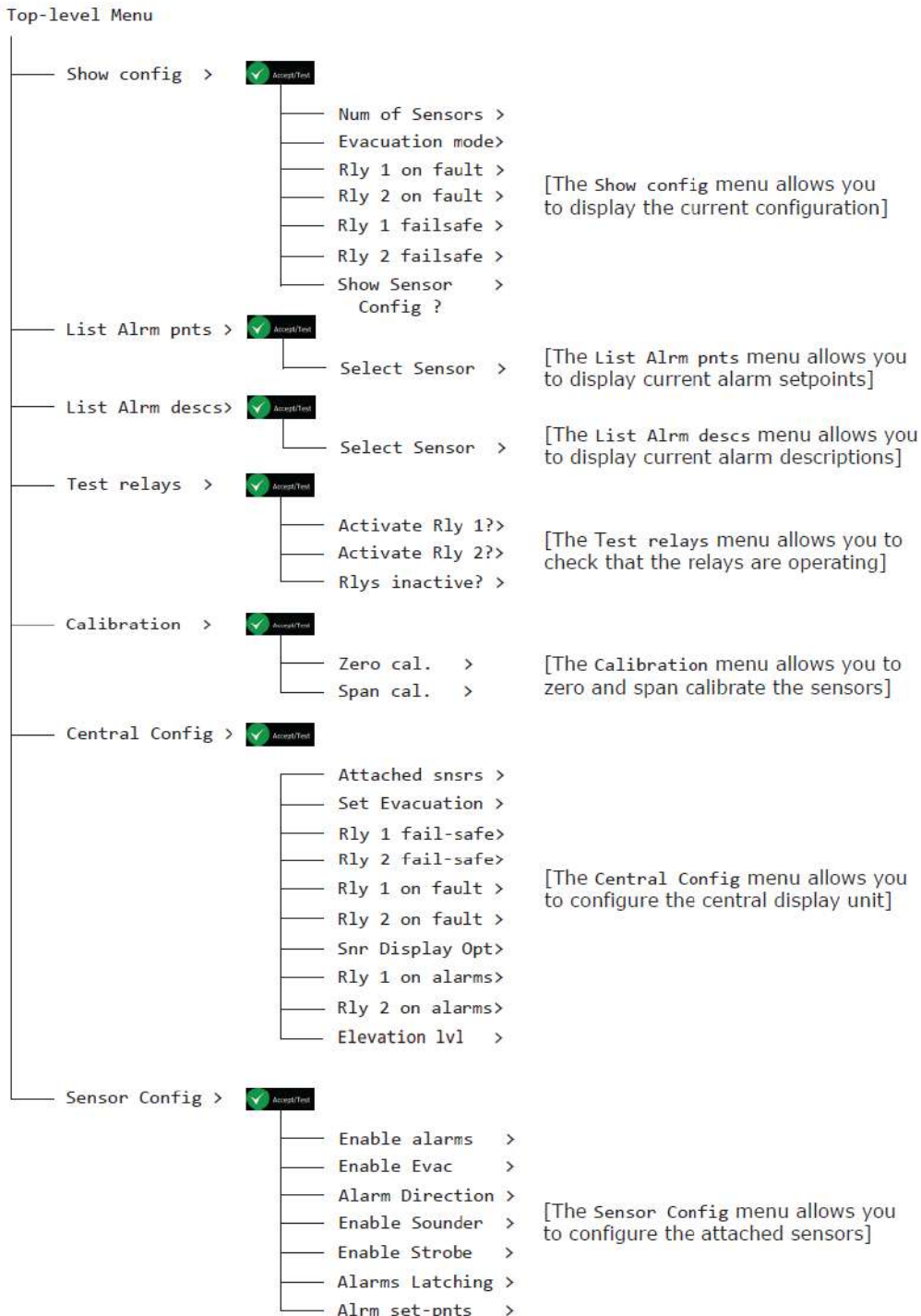

 **NOTE: IF THERE IS NO USER ACTIVITY FOR 60 SECONDS THE MENU WILL TIME OUT.**

4.1 Read-only menus

The Show config option enables you to view read-only information about the system configuration. It displays information on Sensor connections and relay configuration.

NOTE: THE SHOW CONFIG OPTION PROVIDES READ-ONLY INFORMATION THAT CAN NOT BE CHANGED. IF YOU WANT TO SET UP OR CONFIGURE THE AX60+, USE THE TOP-LEVEL MENUS, CENTRAL CONFIG OPTION.

4.1.1 Show configuration (Displayed as Show config)

- 1] To display the Top-level Menu **Show config** option, press and hold down the **Cancel + Cycle** buttons for at least 6 seconds.
- 2] Press **Accept/Test** to display the **Show Config?** Option.
- 3] Press **Cycle** to cycle through each of the config options.

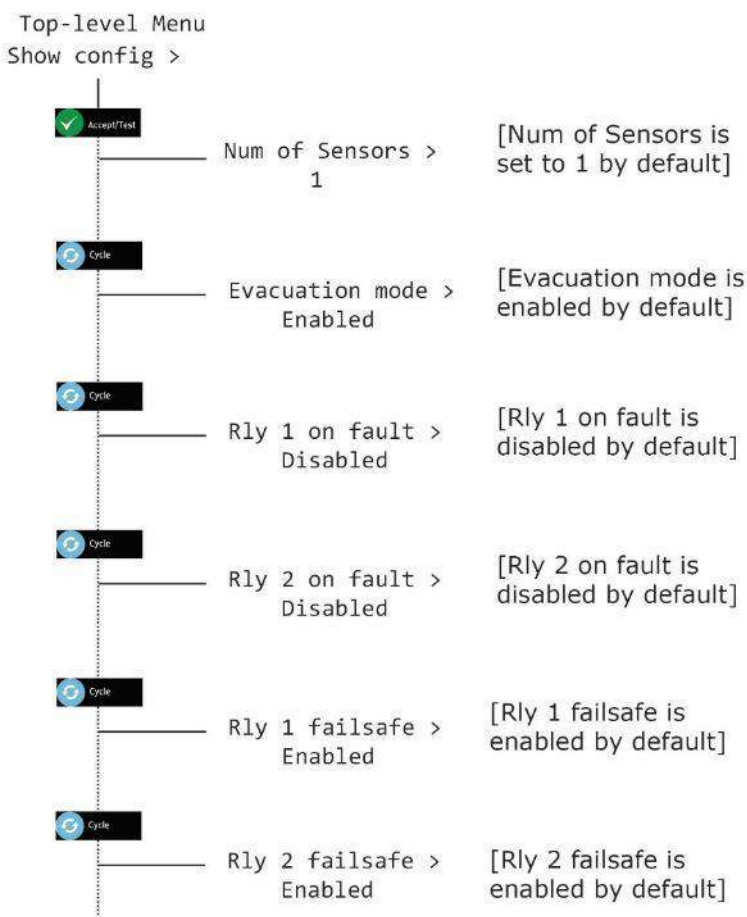

NOTE: TO RETURN TO THE SYSTEM STATUS SCREEN AT ANY TIME PRESS CANCEL. THE CANCEL BUTTON REDISPLAYS THE PREVIOUS MENUS, ONE AT A TIME.

4.1.2 Show Sensor configuration (Displayed as Show Sensor config)

The Show Sensor config option enables you to view read-only information about the sensor configuration. It displays information on Sensor alarms, sounders and strobes.

NOTE: THE SHOW SENSOR CONFIG OPTION PROVIDES READ-ONLY INFORMATION THAT CAN NOT BE CHANGED. IF YOU WANT TO SET UP OR CONFIGURE THE AX60+, USE THE TOP-LEVEL MENU, SENSOR CONFIG OPTION.

- 1] To display the Top-level Menu **Show config** option, press and hold down the **Cancel + Cycle** buttons for at least 6 seconds.
- 2] Press **Accept/Test**, then press **Cycle** six times to display the Show **Sensor Config?** option.
- 3] Press **Accept/Test** to enter the menu, then press **Cycle** to view each config item.

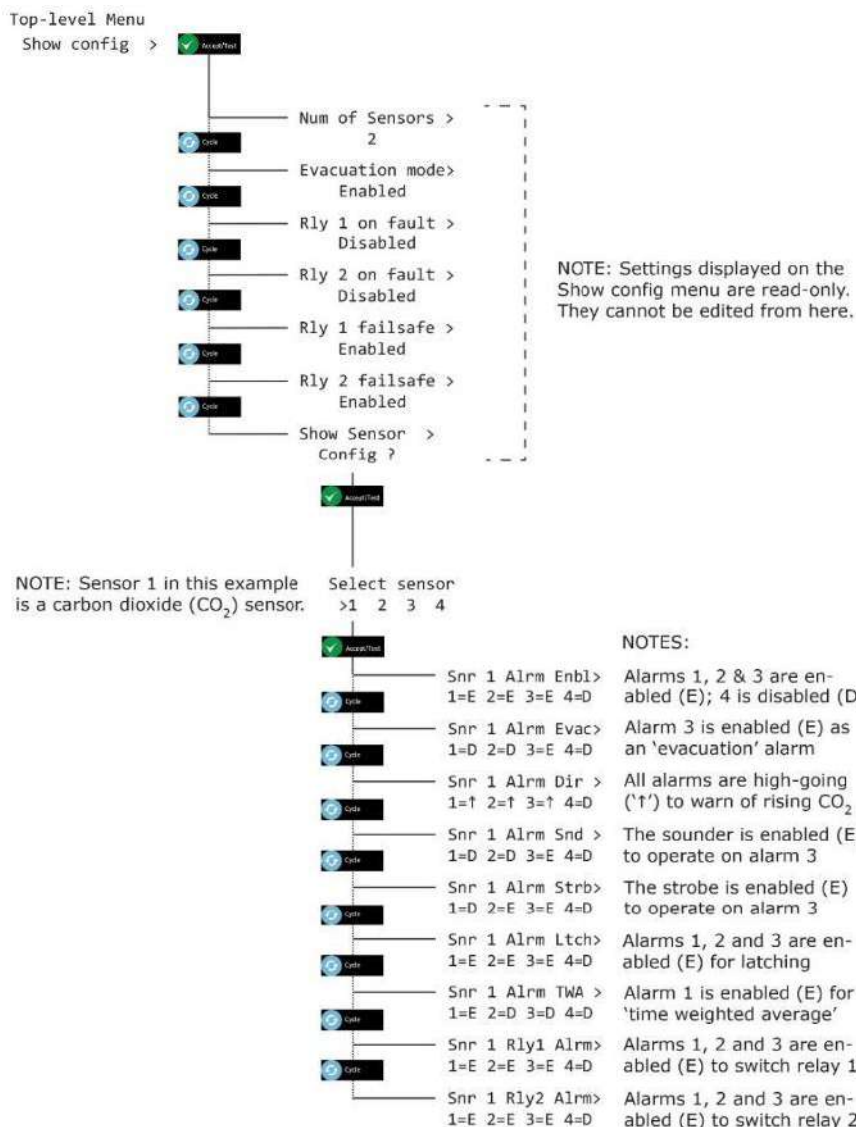

NOTE: TO RETURN TO THE SYSTEM STATUS SCREEN AT ANY TIME PRESS CANCEL. THE CANCEL BUTTON REDISPLAYS THE PREVIOUS MENUS, ONE AT A TIME.

4.1.3 List Alarm pnts (CO₂ example)

The Top-level Menu, List Alarm pnts option enables you to view read-only information about the alarm setpoints configured for each Sensor.

NOTE: THE LIST ALARM PNTS OPTION PROVIDES READ-ONLY INFORMATION THAT CAN NOT BE CHANGED. IF YOU NEED TO SET UP OR CONFIGURE THE ALARM SETPOINTS, USE THE TOP-LEVEL MENU, SENSOR CONFIG, ALARM SET-PNTS OPTION.

- 1] To display the Top-level Menu **List Alarm pnts** option, press and hold down the **Cancel + Cycle** buttons for at least 6 seconds. Then press the **Cycle** button once.
- 2] Press **Accept/Test** to go to the **Select sensor** screen, this displays the sensors and highlights sensor 1.
- 3] Press **Cycle** to highlight other sensors.
- 4] Press **Accept/Test** to select the sensor that you want to view alarms on, then press **Cycle** to cycle through the alarms.

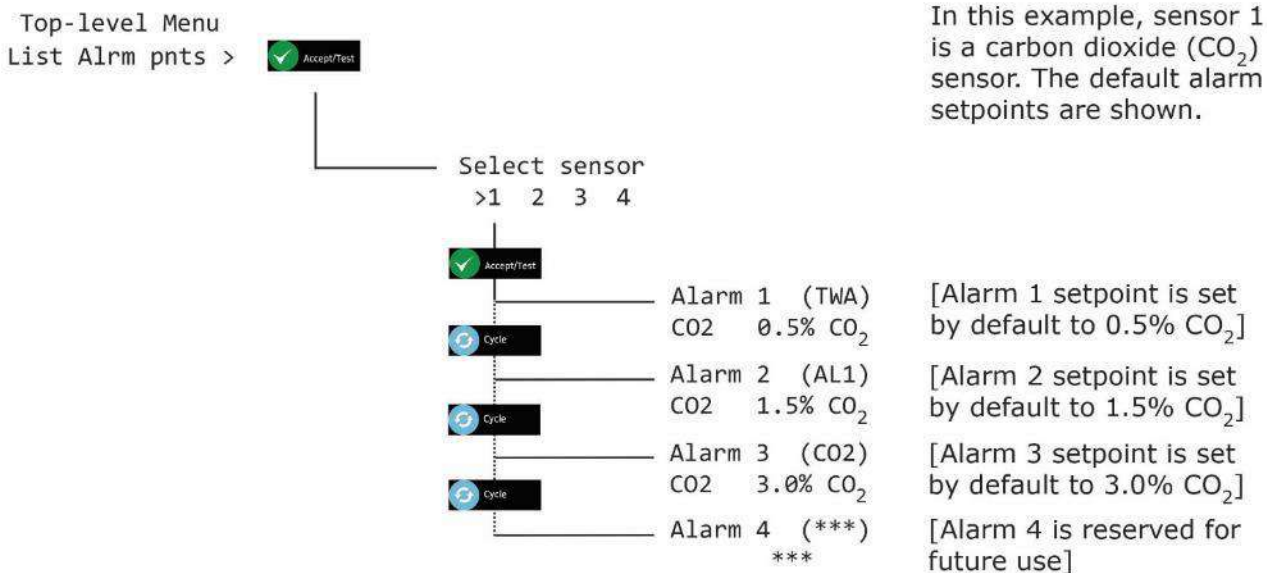

- 5] Press **Cancel** to exit the Alarm screen and return to select another sensor or press **Cancel** to return to the Top-level Menu, **List Alarm pnts**.

4.1.4 List Alarm pnts (O₂ example)

The Top-level Menu, List Alarm pnts option enables you to view read-only information about the alarm setpoints configured for each Sensor.

NOTE: THE LIST ALARM PNTS OPTION PROVIDES READ-ONLY INFORMATION THAT CAN NOT BE CHANGED. IF YOU NEED TO SET UP OR CONFIGURE THE ALARM SETPOINTS, USE THE TOP-LEVEL MENU, SENSOR CONFIG, ALARM SET-PNTS OPTION.

- 1] To display the Top-level Menu **List Alarm pnts** option, press and hold down the **Cancel + Cycle** buttons for at least 6 seconds. Then press the **Cycle** button once.
- 2] Press **Accept/Test** to go to the **Select sensor** screen, this displays the sensors and highlights sensor 1.
- 3] Press **Cycle** to highlight other sensors.
- 4] Press **Accept/Test** to select the sensor that you want to view alarms on, then press **Cycle** to cycle through the alarms.

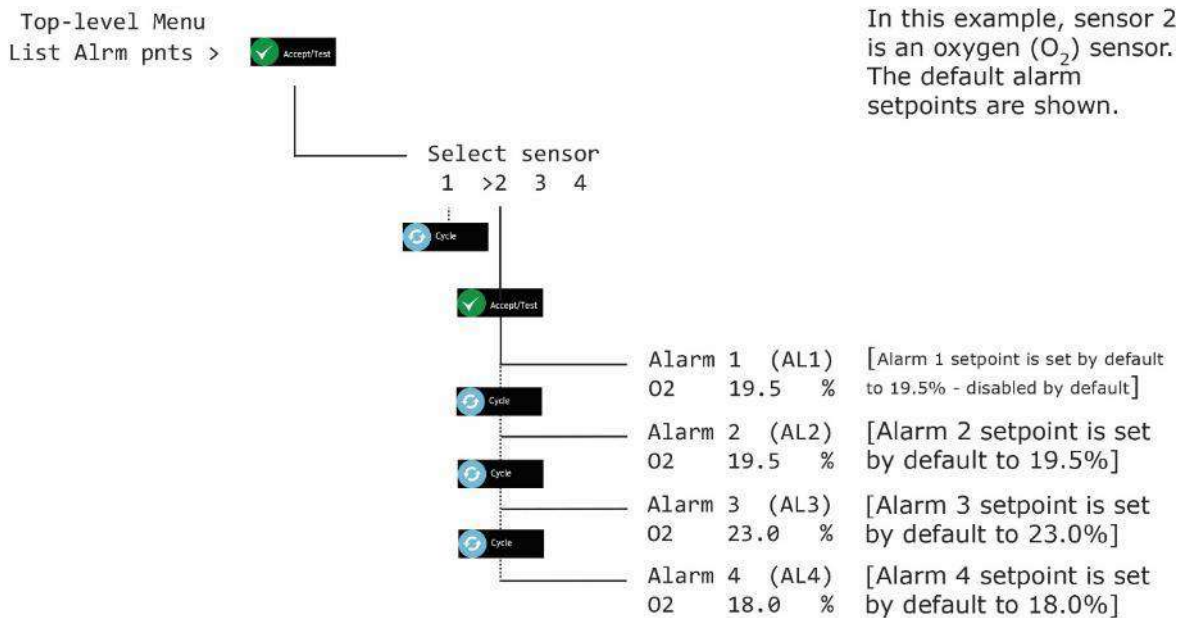

- 5] Press **Cancel** to exit the alarm screen and return to select another sensor or press **Cancel** to return to the Top-level Menu, **List Alarm pnts**.

4.2 List Alarm descriptions (Displayed as List Alarm descsc)

4.2.1 List Alarm descsc (CO₂ example)

The Top-level Menu, List Alarm descsc option enables you to view read-only information about the alarm descriptions configured for each Sensor.

NOTE: THE LIST ALARM DESCSC OPTION PROVIDES READ-ONLY INFORMATION THAT CANNOT BE CHANGED. IF YOU NEED TO SET UP OR CONFIGURE THE ALARM SETPOINTS, USE THE TOP-LEVEL MENU, SENSOR CONFIG, ALARM SET-PNTS OPTION.

- 1] To display the Top-level Menu **List Alarm descsc** option, press and hold down the **Cancel + Cycle** buttons for at least 6 seconds. Then press the **Cycle** button twice.
- 2] Press **Accept/Test** to go to the **Select sensor** screen, this displays the CO₂ sensors and highlights sensor 1.
- 3] Press **Cycle** to highlight other sensors.
- 4] Press **Accept/Test** to select the sensor that you want to view alarms on, then press **Cycle** to cycle through the alarms.

Top-level Menu
List Alarm descsc>

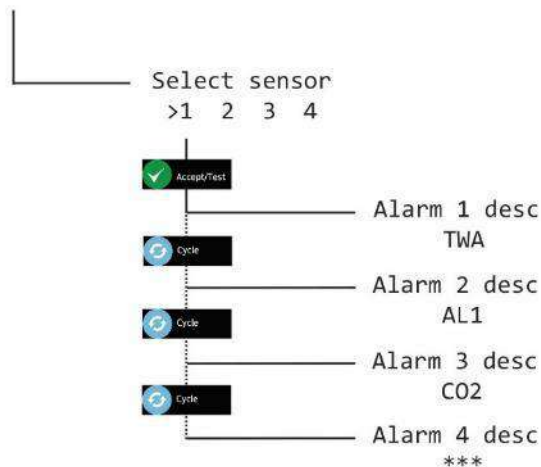

In this example, sensor 1 is a carbon dioxide (CO₂) sensor. The default alarm descriptions are shown.

[^TWA^ is a time-weighted average alarm, default is 0.5% CO₂ over 8 hours]

[^AL1^ is a high CO₂ alarm set by default to 1.5%]

[^CO2^ is a high high CO₂ alarm set by default to 3.0%]

[Reserved for future use]

- 5] Press **Cancel** to exit the Alarm screen and return to select another sensor or press **Cancel** to return to the Top-level Menu, **List Alarm descsc**.

4.2.2 List Alarm descs (O₂ example)

The Top-level Menu, List Alarm descs option enables you to view read-only information about the alarm descriptions configured for each Sensor.

NOTE: THE LIST ALARM DESCS OPTION PROVIDES READ-ONLY INFORMATION THAT CANNOT BE CHANGED. IF YOU NEED TO SET UP OR CONFIGURE THE ALARM SETPOINTS, USE THE TOP-LEVEL MENU, SENSOR CONFIG, ALARM SET-PNTS OPTION.

- 1] To display the Top-level Menu **List Alarm descs** option, press and hold down the **Cancel + Cycle** buttons for at least 6 seconds. Then press the **Cycle** button twice.
- 2] Press **Accept/Test** to go to the **Select sensor** screen, this displays the CO₂ sensors and highlights sensor 1.
- 3] Press **Cycle** to highlight other sensors.
- 4] Press **Accept/Test** to select the sensor that you want to view alarms on, then press **Cycle** to cycle through the alarms.

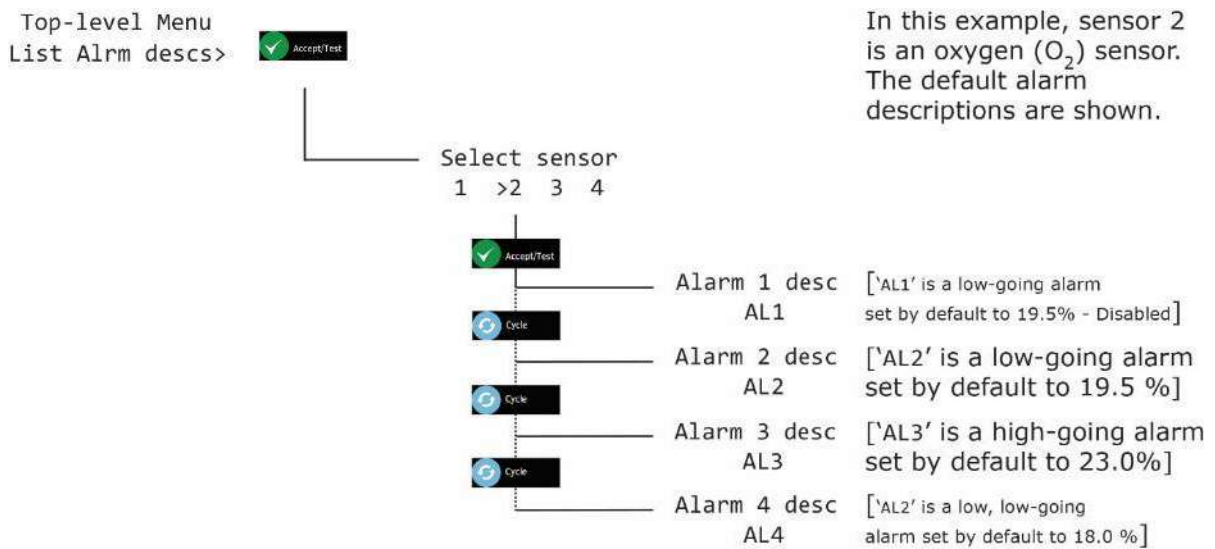

- 5] Press **Cancel** to exit the alarm screen and return to select another sensor or press **Cancel** to return to the Top-level Menu, **List Alarm descs**.

4.3 Testing relays (Displayed as Test relays)

The Test relays option is used to switch Relays 1 and 2 to check they are functioning.

⚠ WARNING: DURING A RELAY TEST, ANY CONNECTED DEVICES OR CIRCUITS WILL OPERATE. DISCONNECT AND ISOLATE ANY DEVICES OR CIRCUITS CONNECTED TO THE RELAYS BEFORE TESTING THEM.

💡 NOTE: IF YOU FORGET TO SWITCH OFF THE RELAYS DURING THE TEST THEY WILL AUTOMATICALLY SWITCH OFF WHEN YOU EXIT THE MENU OR WHEN THE SOFTWARE TIMES OUT AFTER 60 SECONDS.

💡 NOTE: RELAYS ARE NOT TRIGGERED WHEN CARRYING OUT THE 'ALARM TEST' FUNCTION.

- 1] To display the Top-level Menu **Test relays** option, press and hold down the **Cancel+Cycle** buttons for at least 6 seconds. Then press the **Cycle** button three times.
- 2] Press **Accept/Test** to go to the **Activate Rly 1** screen, Press **Accept/Test** to activate the relay.
- 3] Press **Cycle** to go to **Activate Rly 2** screen, Press **Accept/Test** to activate the relay.
- 4] Press **Cycle** to go to **Rlys inactive** screen, Press **Accept/Test** to deactivate the relays.

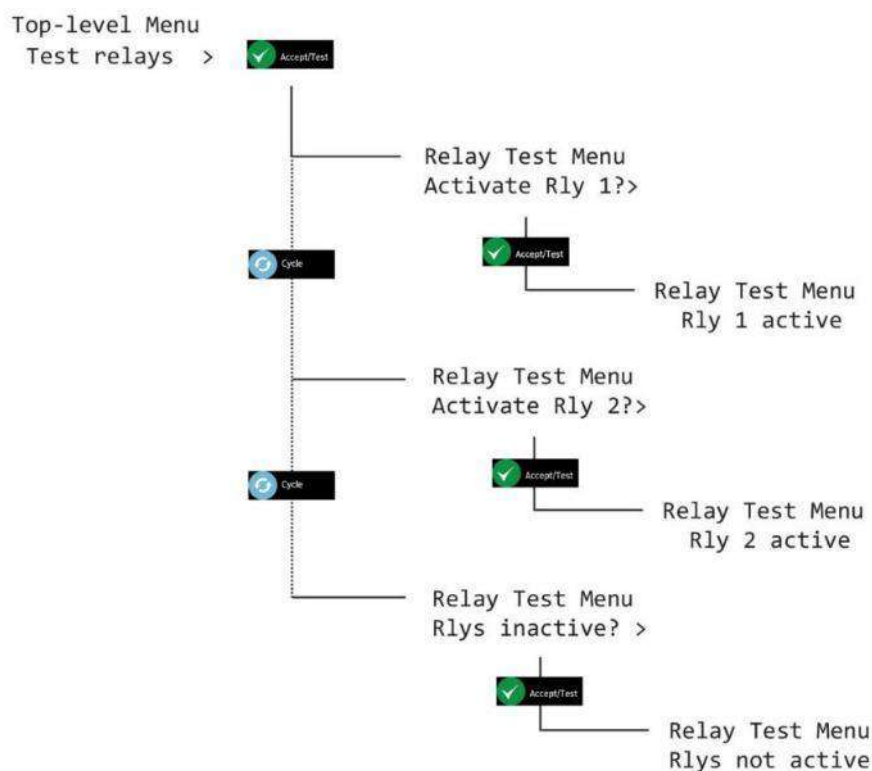

💡 NOTE: YOU WILL HEAR CLICKS FROM THE CENTRAL DISPLAY DURING TESTING OF RELAYS.

- 5] Press **Cancel** to return to Top-level Menu, **Test relays**.

5 Calibrating Ax60+ sensors

NOTE: ANALOX RECOMMEND, FOR BEST PERFORMANCE, THAT ELECTROCHEMICAL CELLS (NEW INSTALLATION OR CELL REPLACEMENT) ARE ALLOWED TO STABILIZE IN THE INSTALLATION ENVIRONMENT FOR 2 HOURS PRIOR TO ANY PROOF TEST OR CALIBRATION.

5.1 Sensor calibration proof test

The Ax60+ Sensors can be checked to ensure that they accurately measure carbon dioxide and display the correct reading.

NOTE: A PROOF TEST SHOULD BE CARRIED OUT AT LEAST EVERY 12 MONTHS*.

*Typical performance, with fixed temperature, humidity and pressure. Adjustment may be required.

Ax60+ Check Kit comprising:		
Part number	Description	Gas type
Contact Analex or source locally	3.0% carbon dioxide, balance nitrogen	CO2 Check O2 Low Check
Contact Analex or source locally	Pure air (20.9% oxygen, balance nitrogen)	O2 High Check
Contact Analex or source locally	20ppm carbon monoxide, 20.9% oxygen, balance nitrogen	CO Check
Contact Analex or source locally	Suitable 0.5-litre/minute regulator to fit calibration gas bottle	
1817-5000	2-metre neoprene tubing	
8000-0910A	Push-in flow adaptor	

Checking Ax60+Sensors is an easy task that does not require software input. This procedure is suitable for the standard Ax60+ option only. Follow the procedure below:

NOTE: IF THE OPTIONAL SENSOR SPLASHGUARD IS FITTED, REMOVE IT BEFORE CHECKING AND/OR CALIBRATING THE SENSORS.

- 1] Ensure the Ax60+ is powered on and operating normally.
- 2] Fit the neoprene tubing to the flow adaptor.
- 3] Fit the flow adaptor into the aperture on the relevant sensor (see below, left).



Step 3] Fit the flow adaptor into the aperture on the Sensor



Step 4] Fit the regulator to the check gas bottle

- 4] Fit the regulator to the relevant check gas bottle.
- 5] Open the regulator valve and allow the check gas to flow across the sensor for 1 to 2 minutes. Do not block the exit of the flow adaptor.
- 6] Ensure that the Ax60+ display reading is as per the table below:

Gas type	Minimum allowable reading	Maximum allowable reading
Carbon dioxide (CO ₂)	30000ppm CO ₂	30150ppm CO ₂
Oxygen (O ₂) Low Check	<1.0%	
Oxygen (O ₂) High Check	19.9% O ₂	21.9% O ₂
Carbon monoxide (CO)	19ppm CO	21ppm CO

- 7] Close the regulator valve, acknowledge the alarm and ventilate the area.

5.2 Sensor calibration adjustment

 **NOTE: THIS SECTION DETAILS THE ZERO AND SPAN CALIBRATION OF AX60+ SENSOR UNITS., ZERO CALIBRATION ADJUSTMENT CAN BE PERFORMED ON DEVICE IF THE SENSOR HAS AN ACCEPT/TEST BUTTON. SEE SECTION 5.3**



The Ax60+ Sensor(s) can be recalibrated to ensure they accurately measure gas at the specified levels.

 **FOR AX60+ CO SENSORS BEING USED IN A HELIUM BACKGROUND APPLICATION, PLEASE SEE APPENDIX J PRIOR TO CALIBRATION.**

Ax60+ Calibration Kit comprising:		
Part number	Description	Gas type
Contact Analox or source locally	Pure air (20.9% oxygen, balance nitrogen)	CO ₂ Zero O ₂ Span CO Zero
Contact Analox or source locally	3% carbon dioxide, balance nitrogen	CO ₂ Span O ₂ Zero
Contact Analox or source locally	20ppm carbon monoxide, 20.9% oxygen, balance nitrogen	CO Span
Contact Analox or source locally	Suitable 0.5-litre/minute regulator to fit calibration gas bottle	
1817-5000	2-metre neoprene tubing	
8000-0910A	Push-in flow adaptor	

 **NOTE: ZERO CALIBRATION ADJUSTMENT MUST BE PERFORMED BEFORE SPAN CALIBRATION ADJUSTMENT.**

5.2.1 Sensor zero calibration (Displayed as Zero cal.)

-  **NOTE:** THE SENSOR THAT IS BEING CALIBRATED IS AUTOMATICALLY DISABLED DURING CALIBRATION. THE OTHER SENSORS CONTINUE TO OPERATE.
-  **NOTE:** CALIBRATION MODE AUTOMATICALLY TIMES OUT AFTER TEN MINUTES.

To zero calibrate a Sensor, follow the procedure below (in both text and example menu map):

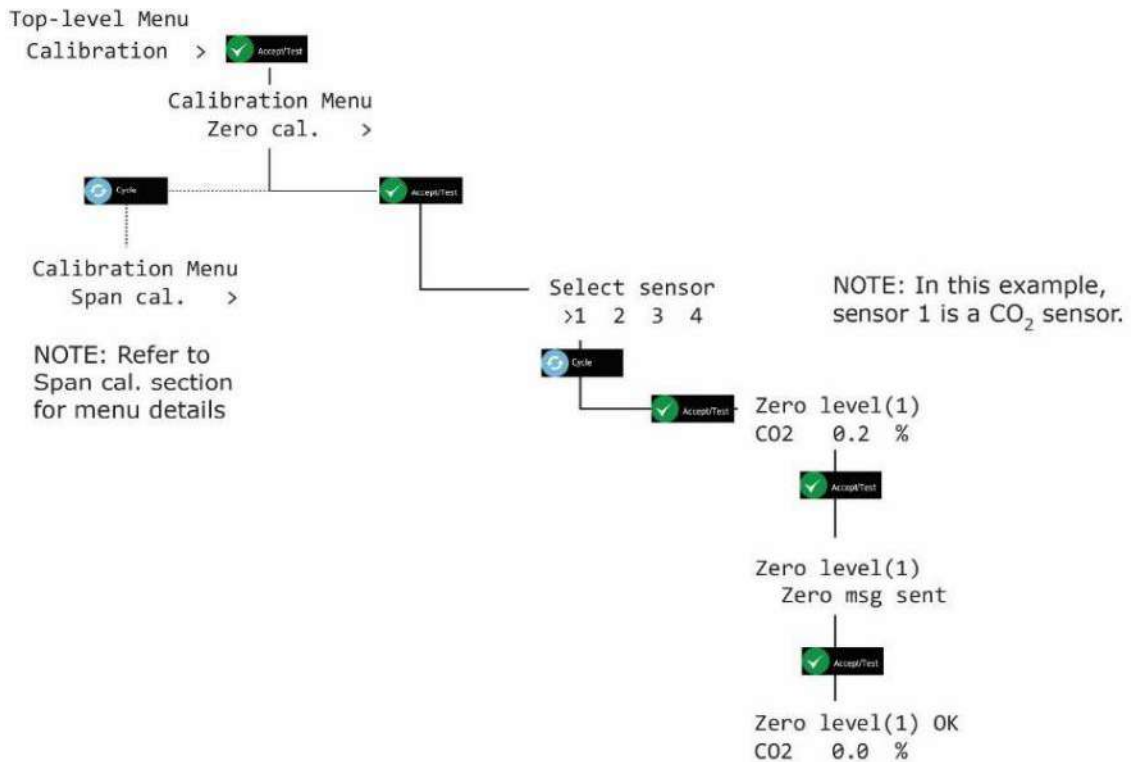

- 1]** Ensure the Ax60+ is powered on and operating normally.
- 2]** Press and hold **Cancel+Cycle** for 6 seconds to display Top-level Menu.
- 3]** Press **Cycle** four times to display **Calibration**. Press **Accept/Test** to display **Zero cal**.
- 4]** Press **Accept/Test** to show the **Select sensor** screen, press **Cycle** to select the sensor you want to calibrate.
- 5]** Press **Accept/Test** to select the sensor. The **Zero level (#)** screen displays.
- 6]** Fit the neoprene tubing to the flow adaptor.
- 7]** Fit the flow adaptor into the aperture on the sensor.
- 8]** Fit the regulator to the relevant zero gas bottle.
- 9]** Open the regulator valve and allow the zero gas to flow across the sensor for 1 to 2 minutes. Do not block the exit of the flow adaptor.
- 10]** The reading on the **Zero level** screen will begin to reduce. Wait for the reading to stabilise.
- 11]** Press **Accept/Test** to confirm the zero calibration.
- 12]** If zero calibration is successful, the **Zero msg sent** screen is displayed as per following example.



13] Press **Cancel** repeatedly to return to system status screen.

- 🔔 **NOTE:** IF THE CALIBRATION IS UNSUCCESSFUL, A FAULT CODE MAY BE DISPLAYED. REFER TO SECTION 11 FOR DETAILS.
- 🔔 **NOTE:** THE VALUE SHOWN DURING A CALIBRATION IS THE 'RAW' SENSOR READING. WHEN YOU EXIT THE MENU AND RETURN TO THE SYSTEM STATUS SCREEN THE VALUE SHOWN IS A SLIGHTLY ELEVATED VALUE.
- ⚠️ **CAUTION:** ONLY ONE SENSOR CAN BE CALIBRATED AT A TIME. TO CALIBRATE ANOTHER SENSOR, EXIT THE MENUS BACK TO THE SYSTEM STATUS SCREEN THEN REPEAT THE CALIBRATION PROCESS FOR THE NEXT SENSOR.

5.2.2 Sensor span calibration (Displayed as Span cal.)

-  **NOTE: THE SENSOR THAT IS BEING CALIBRATED IS AUTOMATICALLY DISABLED DURING CALIBRATION. THE OTHER SENSORS CONTINUE TO OPERATE.**
-  **NOTE: CALIBRATION MODE AUTOMATICALLY TIMES OUT AFTER TEN MINUTES.**

The table below shows the span reading increments that each of the different sensors can be incremented by, for CO₂ only, by pressing and holding the Cycle button, the increment can be changed from 0.01% CO₂ to 0.1% CO₂

Gas type	Minor span gas increment	Major span gas increment (Press & hold Cycle button)	Span range
Carbon dioxide (CO ₂)	0.01%	0.1%	2.50% to 6.00% CO ₂
Oxygen (O ₂)	0.1%	1.0%	20.9% to 25% O ₂
Carbon monoxide (CO)	1ppm	N/A	5ppm to 25ppm CO

To span calibrate a Sensor, follow the procedure below (in both text and example menu map):

- 1] Ensure the Ax60+ is powered on and operating normally.
- 2] Press and hold **Cancel+Cycle** for 6 seconds to display Top-level Menu.
- 3] Press **Cycle** four times to display **Calibration**. Press **Accept/Test** to display **Zero cal**.
- 4] Press **Cycle** to show **Span cal.**, press **Accept/Test** to show the **Select sensor** screen, press **Cycle** to select the sensor you want to calibrate.
- 5] Press **Accept/Test** to show the **Span Cal Value** screen.
- 6] Press **Cycle** repeatedly to enter the span calibration value you want.
- 7] To reset the value and start again, repeatedly press **Cycle** or press and hold **Cycle** until you exceed the relevant span range, this will take the value back to the start of the span range and you can cycle through again until you reach the required value.
- 8] Press **Accept/Test** to confirm the span calibration value.
- 9] Fit the neoprene tubing to the flow adaptor.
- 10] Fit the flow adaptor into the aperture on the Sensor.
- 11] Fit the regulator to the relevant span gas bottle.
- 12] Open the regulator valve and allow the span gas to flow across the sensor for 1 to 2 minutes. Do not block the exit of the flow adaptor.
- 13] The reading on the Span level screen will begin to increase. Wait for the reading to stabilise.
- 14] Press **Accept/Test** to confirm the calibration.
- 15] If span calibration is successful, the **Span msg sent** screen is displayed as per following example.

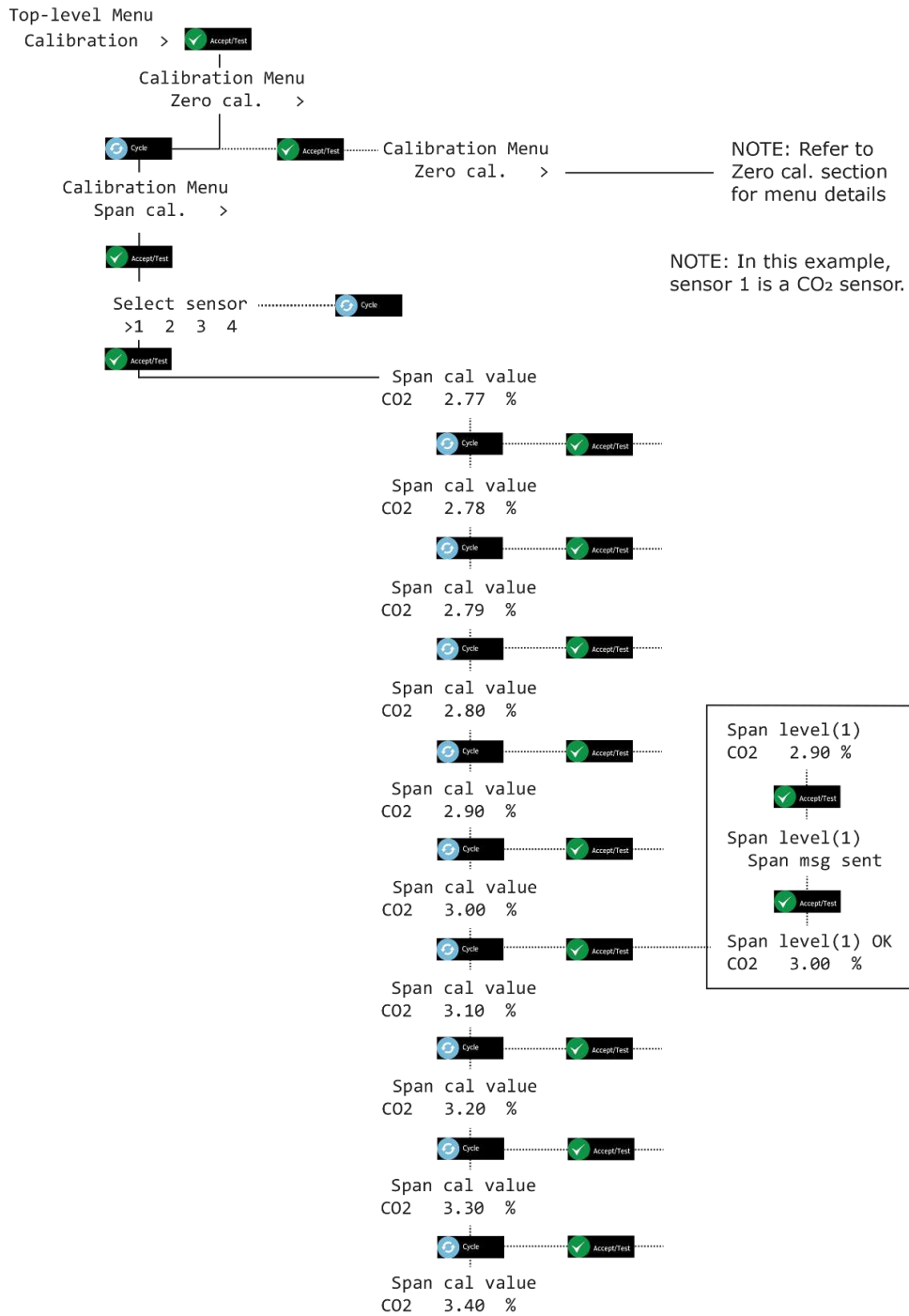

NOTE: IF THE CALIBRATION IS UNSUCCESSFUL, A FAULT CODE MAY BE DISPLAYED. REFER TO SECTION 11 FOR DETAILS.

NOTE: THE VALUE SHOWN DURING A CALIBRATION IS THE 'RAW' SENSOR READING. WHEN YOU EXIT THE MENU AND RETURN TO THE SYSTEM STATUS SCREEN THE VALUE SHOWN IS A SLIGHTLY ELEVATED VALUE.

5.3 Zero calibration adjustment on device



NOTE: THIS PROCEDURE INVOLVES THE USE OF ZERO GAS. ZERO GAS IS ANY GAS CONTAINING NO SENSOR TARGET GAS. PLEASE REFER TO THE TABLE AT THE START OF SECTION 5.2 FOR RELEVANT ZERO GAS.



NOTE: THE UNIT WILL MAKE A BUZZ SOUND ON EACH PRESS OF THE MODE BUTTON.

- 1] Under normal operation, the green light will be flashing, and the red light will be off.
- 2] From normal operation, press the green button three times (each press must be within 1 second of the previous). If this is done successfully, the unit will buzz three times then the green light will begin flashing at a reduced rate and the red light will be off, indicating that technician mode has been selected. If this is done inadvertently, press the green button once to cancel and return to normal operation. Should there be no activity after one minute it will time out and return to normal operation signified by a one-second buzz.
- 3] From technician mode, press the green button four times (each press must be within 1 second of the previous). If this is done successfully, the unit will buzz four times, the green light will continue flashing and the red light will be solid on, indicating that zero calibration adjustment mode has been selected. If this is done inadvertently, or if another mode is selected, press the green button once to cancel and return to technician mode. If there is no activity after five minutes, it will time out and return to normal operation, signified by a one-second buzz.
- 4] Pass a suitable zero gas over the sensor for one minute at a flow rate of between 0.2 and 1 litre per minute (LPM).
- 5] From zero calibration adjustment mode, press the green button twice (each press must be within 1 second of the previous). If this is done successfully, the unit will buzz twice, the green light will continue flashing and the red light will begin flashing at the same rate. The instrument will then monitor the gas sample for a period of one minute.
- 6] After the one-minute sample period ends, the unit will show if the calibration has passed or failed.
 - a) **If the calibration has passed, the unit will buzz once, the green light will be solid on and the red light will be off**
 - b) **If the calibration has failed, the unit will buzz twice, the green light will be off and the red light will be solid on.**
- 7] If the calibration fails, check that:
 - a) **The gas cylinder contains the correct gas for the sensor type.**
 - b) **The calibration gas adaptor is held over the sensor properly.**
 - c) **The calibration gas pipework is not damaged or pinched.**
 - d) **The calibration gas flow rate is between 0.2 and 1 litre per minute (LPM).**
- 8] Press the green button once to return to technician mode and repeat the process to correct a failed calibration adjustment. If there is no activity after one minute, it will time out and return to normal operation, signified by a one-second buzz.



NOTE: IF THE ZERO CALIBRATION ADJUSTMENT FAILED, THE PROCEDURE SHOULD BE PERFORMED AGAIN, AND IF STILL FAULTY, CONTACT YOUR SUPPLIER.

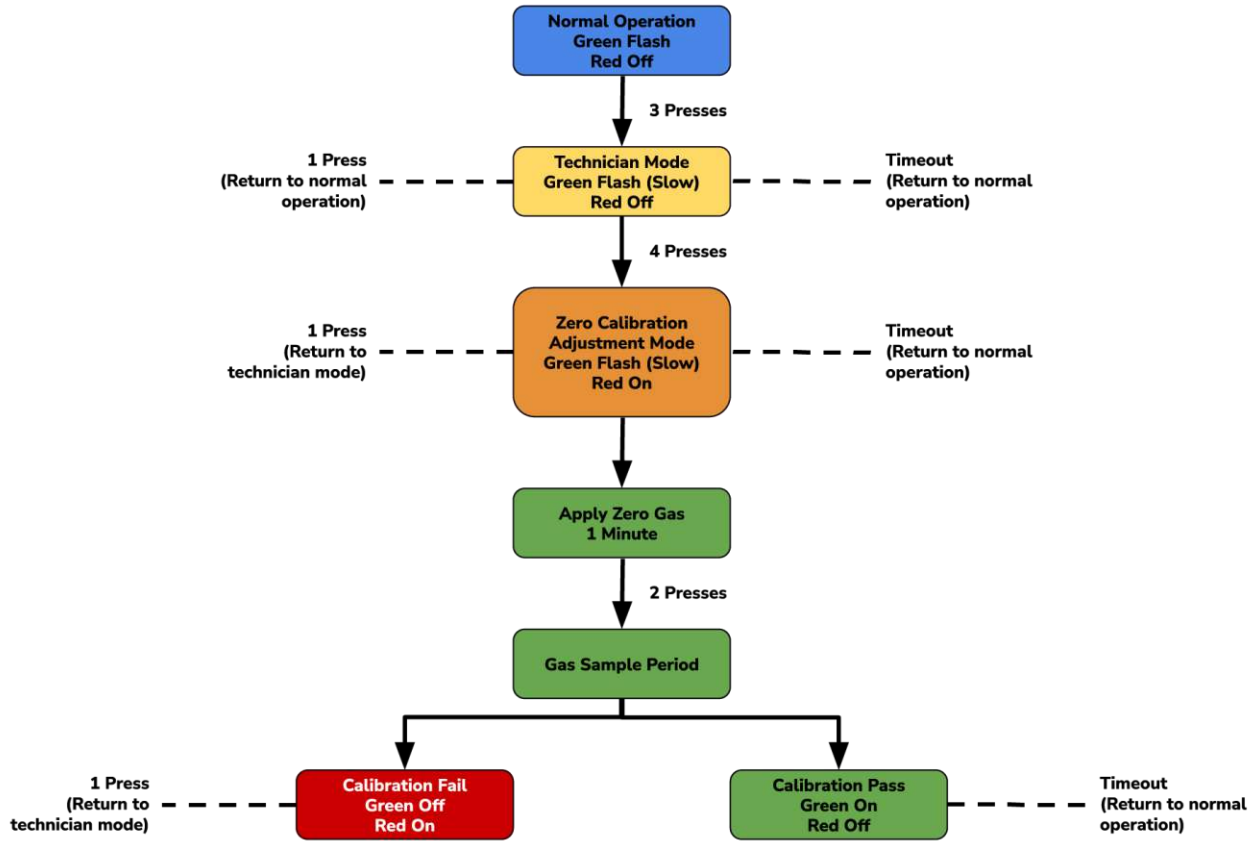

6 Calibrating Ax60+ Kiosk sensors



NOTE: THIS SECTION DETAILS THE ZERO AND SPAN CALIBRATION OF AN AX60+ KIOSK SENSOR UNIT USING A CENTRAL UNIT. IF YOU DO NOT HAVE A CENTRAL UNIT, ZERO CALIBRATION ADJUSTMENT CAN BE DONE ON THE DEVICE. SEE SECTION 6.3

6.1 CO₂ sensor calibration proof test

The Ax60+ CO₂ Sensors can be checked to ensure that they accurately measure carbon dioxide and trigger the alarms correctly.

 **NOTE:** A PROOF TEST SHOULD BE CARRIED OUT AT LEAST EVERY 12 MONTHS*.

*Typical performance, with fixed temperature, humidity and pressure. Adjustment may be required.

Ax60+ CO ₂ Check Kit comprising:	
Part number	Description
Contact Analox or source locally	1.6% carbon dioxide, balance nitrogen (low alarm check gas)
Contact Analox or source locally	3.2% carbon dioxide, balance nitrogen (high alarm check gas)
Contact Analox or source locally	Suitable 0.5-litre/minute regulator to fit calibration gas bottle
1817-5000	2-metre neoprene tubing
8000-0910A	Push-in flow adaptor

Checking CO₂ Sensors is an easy task that does not require software input. This procedure is suitable for the Ax60+ Kiosk option only. Follow the procedure below:

 **NOTE:** IF THE OPTIONAL SENSOR SPLASHGUARD IS FITTED, REMOVE IT BEFORE CHECKING AND/OR CALIBRATING THE SENSORS.

- 1] Ensure the Ax60+/Ax60+ Kiosk is powered on and operating normally.
- 2] Fit the neoprene tubing (1817-5000) to the flow adaptor (8000-0910A).

3] Fit the flow adaptor into the aperture on the CO₂ Sensor (see below, left).



Step [3] Fit the flow adaptor into the aperture on the CO₂ Sensor



Step [4] Fit the regulator to the 1.6% CO₂ gas bottle

- 4] Fit the regulator to the 1.6% CO₂ gas bottle (see above, right).
- 5] Carefully open the regulator valve and allow the 1.6% CO₂ gas to flow across the sensor. Do not block the exit of the flow adaptor.
- 6] Ensure that the Ax60+/Ax60+ Kiosk low alarm (1.5% CO₂) operates.
- 7] Close the regulator valve, acknowledge the alarm and ventilate the area.
- 8] Repeat the procedure using 3.2% CO₂ gas to check the high alarm (3% CO₂).

6.2 CO₂ sensor calibration adjustment

The Ax60+ CO₂ Sensor(s) can be recalibrated to ensure they accurately measure carbon dioxide at the specified levels. Analox can supply the following calibration kit:

Ax60+ CO₂ Calibration Kit comprising:	
Part number	Description
Contact Analox or source locally	100% nitrogen (zero gas)
Contact Analox or source locally	3% carbon dioxide, balance nitrogen (span gas)
Contact Analox or source locally	Suitable 0.5-litre/minute regulator to fit calibration gas bottle
1817-5000	2-metre neoprene tubing
8000-0910A	Push-in flow adaptor

Recalibrating CO₂ Sensors is a similar task to checking but it also requires software input. The recalibration procedure is the same for both the standard Ax60+ and the Ax60+ Kiosk. However, before you adjust the Ax60+ Kiosk you must temporarily fit the portable calibration unit, part number AX60CNQNXA (see section 10 for further details).

Calibration adjustment is a two-point process: a 'zero calibration adjustment' and a 'span calibration adjustment'.

 **NOTE: ZERO CALIBRATION ADJUSTMENT MUST BE PERFORMED BEFORE SPAN CALIBRATION ADJUSTMENT.**

6.2.1 CO₂ sensor zero calibration (Displayed as Zero cal.)

 **NOTE: THE SENSOR THAT IS BEING CALIBRATED IS AUTOMATICALLY DISABLED DURING CALIBRATION. THE OTHER SENSORS CONTINUE TO OPERATE.**

 **NOTE: CALIBRATION MODE AUTOMATICALLY TIMES OUT AFTER TEN MINUTES.**

To zero calibrate a CO₂ Sensor, follow the procedure below (in both text and menu map):

- 1] Ensure the Ax60+/Ax60+ Kiosk is powered on and operating normally.
- 2] Press and hold **Cancel+Cycle** for 6 seconds to display Top-level Menu.
- 3] Press **Cycle** four times to display **Calibration**. Press **Accept/Test** to display Zero cal.
- 4] Press **Accept/Test** to show the **Select sensor** screen, press **Cycle** to select the Sensor you want to calibrate.
- 5] Press **Accept/Test** to select the sensor. The **Zero level (#)** screen displays.
- 6] Fit the neoprene tubing (1817-5000) to the flow adaptor (8000-0910A).
- 7] Fit the flow adaptor into the aperture on the CO₂ sensor.
- 8] Fit the regulator to the 100% nitrogen zero gas.
- 9] Carefully open the regulator valve and allow the zero gas to flow across the sensor for 1 to 2 minutes. Do not block the exit of the flow adaptor.
- 10] The CO₂ reading on the **Zero level** screen will begin to reduce. Wait for the reading to stabilise at around 0.0%.

 **NOTE: THE READING MAY NOT RETURN EXACTLY TO ZERO. THIS IS NORMAL DURING THE CALIBRATION PROCESS.**

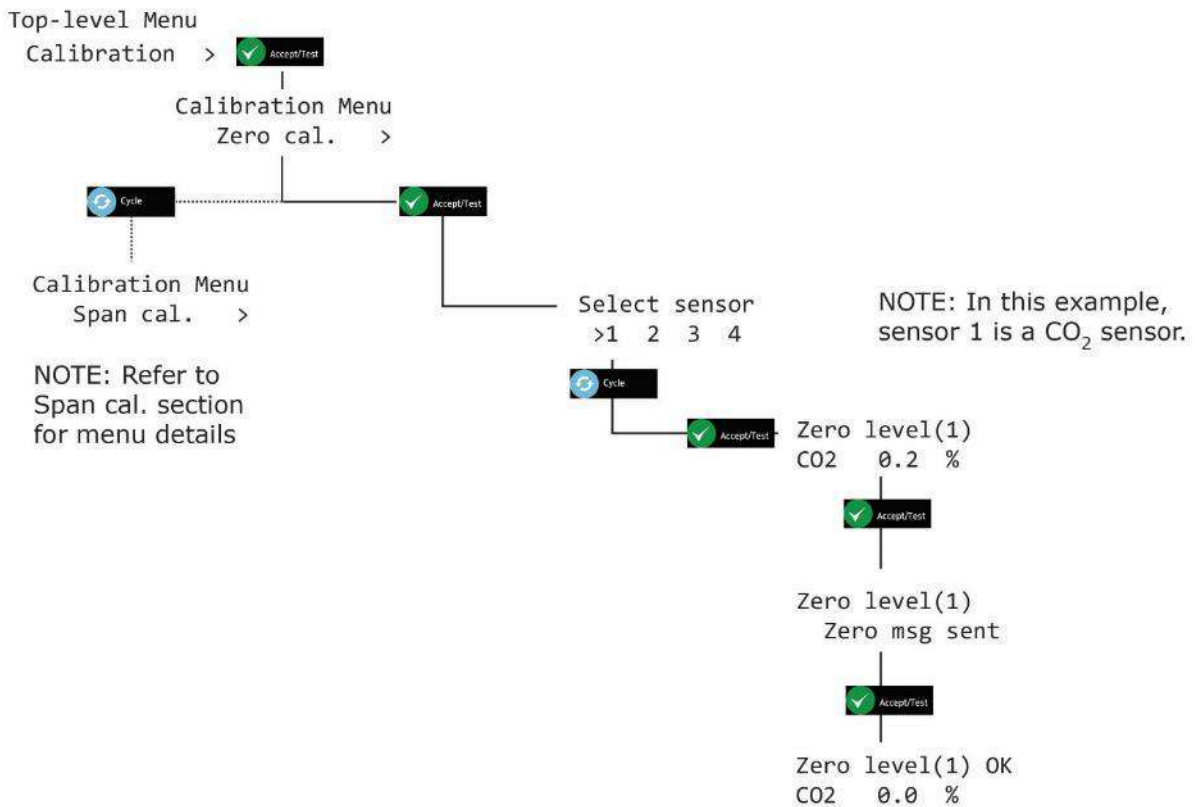

- 11] Press **Accept/Test** to confirm the zero calibration.
- 12] If zero calibration is successful, the **Zero msg sent** screen is displayed.



13] Press **Cancel** repeatedly to return to system status screen.

- NOTE:** IF THE CALIBRATION IS UNSUCCESSFUL, A FAULT CODE MAY BE DISPLAYED. REFER TO SECTION 11 FOR DETAILS.
- NOTE:** THE VALUE SHOWN DURING A CALIBRATION IS THE 'RAW' SENSOR READING. WHEN YOU EXIT THE MENU AND RETURN TO THE SYSTEM STATUS SCREEN THE VALUE SHOWN IS A SLIGHTLY ELEVATED VALUE.
- CAUTION:** ONLY ONE SENSOR CAN BE CALIBRATED AT A TIME. THIS IS BECAUSE A SENSOR IS REMOVED FROM CALIBRATION MODE ONLY WHEN YOU EXIT FROM THE MENUS. TO CALIBRATE ANOTHER SENSOR, EXIT THE MENUS BACK TO THE SYSTEM STATUS SCREEN THEN REPEAT THE CALIBRATION PROCESS FOR THE NEXT SENSOR.

6.2.2 CO₂ sensor span calibration (Displayed as Span cal.)

-  **NOTE: THE SENSOR THAT IS BEING CALIBRATED IS AUTOMATICALLY DISABLED DURING CALIBRATION. THE OTHER SENSORS CONTINUE TO OPERATE.**
-  **NOTE: CALIBRATION MODE AUTOMATICALLY TIMES OUT AFTER TEN MINUTES.**

Standard increments for calibration are factory set at 0.01 %, however, by pressing and holding the Cycle button this increases the increment value x 10 (0.10 %)

To span calibrate a CO₂ Sensor, follow the procedure below (in both text and menu map):

- 1]** Ensure the Ax60+/Ax60+ Kiosk is powered on and operating normally.
- 2]** Press and hold **Cancel+Cycle** for 6 seconds to display Top-level Menu.
- 3]** Press **Cycle** four times to display **Calibration**. Press **Accept/Test** to display Zero cal.
- 4]** Press **Cycle** to show **Span cal.**, press **Accept/Test** to show the **Select sensor** screen, press **Cycle** to select the sensor you want to calibrate.
- 5]** Press **Accept/Test** to show the **Span Cal Value** screen.
- 6]** Press **Cycle** repeatedly to enter the span calibration value you want in 0.01% increments or press and hold **Cycle** to increment the value at 0.10% increments.
- 7]** To reset the value and start again, repeatedly press **Cycle** or press and hold **Cycle** until you exceed 6.00 %, this will take the value back to 2.50 % and you can cycle through again until you reach the required value.
- 8]** Press **Accept/Test** to confirm the span calibration value (for example, 3.00 %).
- 9]** Fit the neoprene tubing (1817-5000) to the flow adaptor (8000-0910A).
- 10]** Fit the flow adaptor into the aperture on the CO₂ sensor.
- 11]** Fit the regulator to the 3% CO₂ span gas.
- 12]** Carefully open the regulator valve and allow the span gas to flow across the sensor for 1 to 2 minutes. Do not block the exit of the flow adaptor.
- 13]** The CO₂ reading on the **Span level** screen will begin to increase. Wait for the reading to stabilise at (or close to) 3.00 %.
- 14]** Press **Accept/Test** to confirm the calibration.
- 15]** If span calibration is successful, the **Span msg sent** screen is displayed.

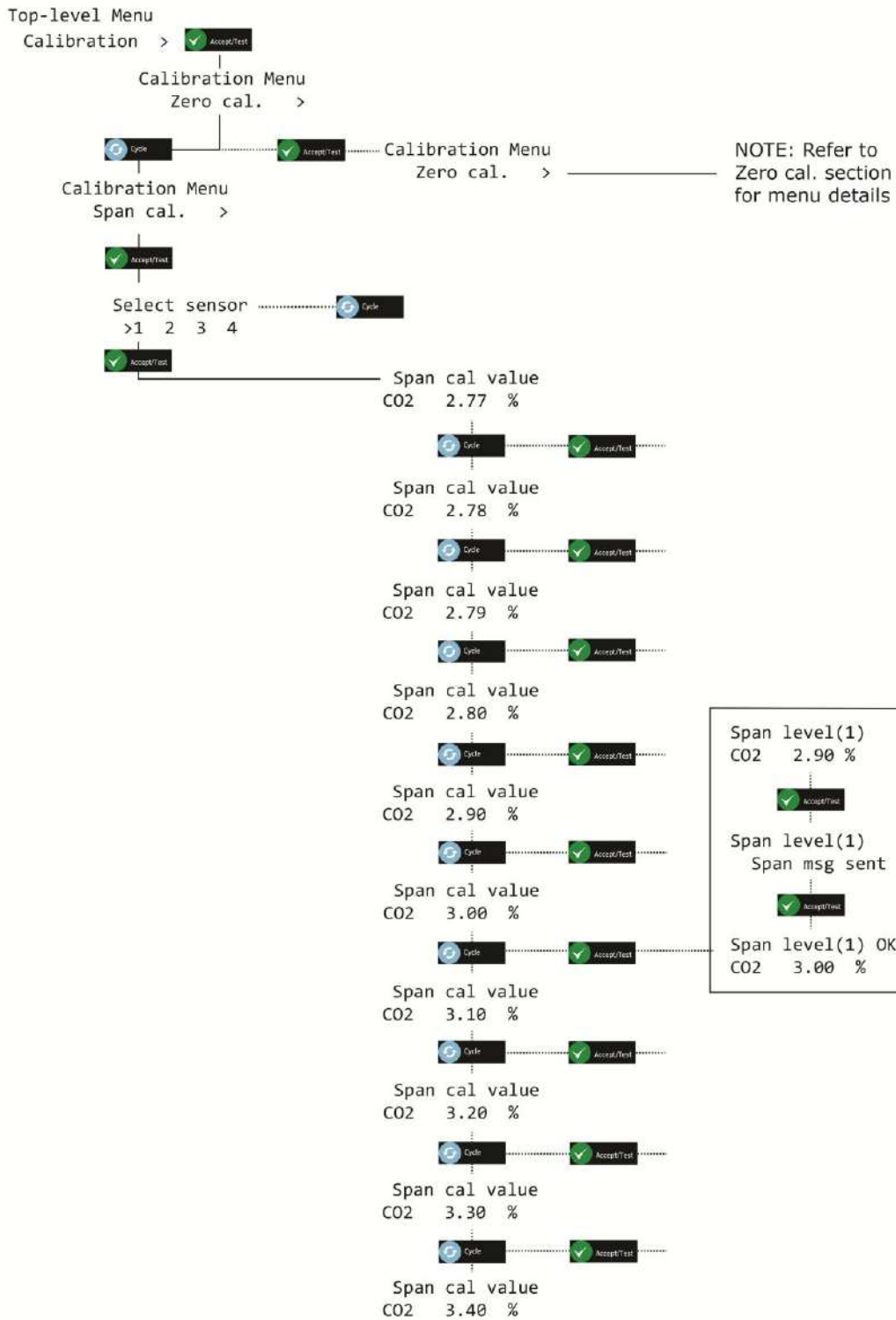

- NOTE:** IF THE CALIBRATION IS UNSUCCESSFUL, A FAULT CODE MAY BE DISPLAYED. REFER TO SECTION 11 FOR DETAILS.
- NOTE:** THE VALUE SHOWN DURING A CALIBRATION IS THE 'RAW' SENSOR READING. WHEN YOU EXIT THE MENU AND RETURN TO THE SYSTEM STATUS SCREEN THE VALUE SHOWN IS A SLIGHTLY ELEVATED VALUE.

6.3 Zero calibration adjustment on device



NOTE: THIS PROCEDURE INVOLVES THE USE OF ZERO GAS. ZERO GAS IS ANY GAS CONTAINING NO SENSOR TARGET GAS. PURE NITROGEN IS SUITABLE FOR ZERO CALIBRATION OF ANY AX60+ SENSOR UNIT.



NOTE: THE UNIT WILL MAKE A BUZZ SOUND ON EACH PRESS OF THE MODE BUTTON.

- 1] Under normal operation, the green light will be flashing, and the red light will be off.
- 2] From normal operation, press the green button three times (each press must be within 1 second of the previous). If this is done successfully, the unit will buzz three times then the green light will begin flashing at a reduced rate and the red light will be off, indicating that technician mode has been selected. If this is done inadvertently, press the green button once to cancel and return to normal operation. Should there be no activity after one minute it will time out and return to normal operation signified by a one-second buzz.
- 3] From technician mode, press the green button four times (each press must be within 1 second of the previous). If this is done successfully, the unit will buzz four times, the green light will continue flashing and the red light will be solid on, indicating that zero calibration adjustment mode has been selected. If this is done inadvertently, or if another mode is selected, press the green button once to cancel and return to technician mode. If there is no activity after five minutes, it will time out and return to normal operation, signified by a one-second buzz.
- 4] Pass a suitable zero gas over the sensor for one minute at a flow rate of between 0.2 and 1 litre per minute (LPM).
- 5] From zero calibration adjustment mode, press the green button twice (each press must be within 1 second of the previous). If this is done successfully, the unit will buzz twice, the green light will continue flashing and the red light will begin flashing at the same rate. The instrument will then monitor the gas sample for a period of one minute.
- 6] After the one-minute sample period ends, the unit will show if the calibration has passed or failed.
 - c) **If the calibration has passed, the unit will buzz once, the green light will be solid on and the red light will be off**
 - d) **If the calibration has failed, the unit will buzz twice, the green light will be off and the red light will be solid on.**
- 7] If the calibration fails, check that:
 - e) **The gas cylinder contains the correct gas for the sensor type.**
 - f) **The calibration gas adaptor is held over the sensor properly.**
 - g) **The calibration gas pipework is not damaged or pinched.**
 - h) **The calibration gas flow rate is between 0.2 and 1 litre per minute (LPM).**

- 8] Press the green button once to return to technician mode and repeat the process to correct a failed calibration adjustment. If there is no activity after one minute, it will time out and return to normal operation, signified by a one-second buzz.



NOTE: IF THE ZERO CALIBRATION ADJUSTMENT FAILED, THE PROCEDURE SHOULD BE PERFORMED AGAIN, AND IF STILL FAULTY, CONTACT YOUR SUPPLIER.

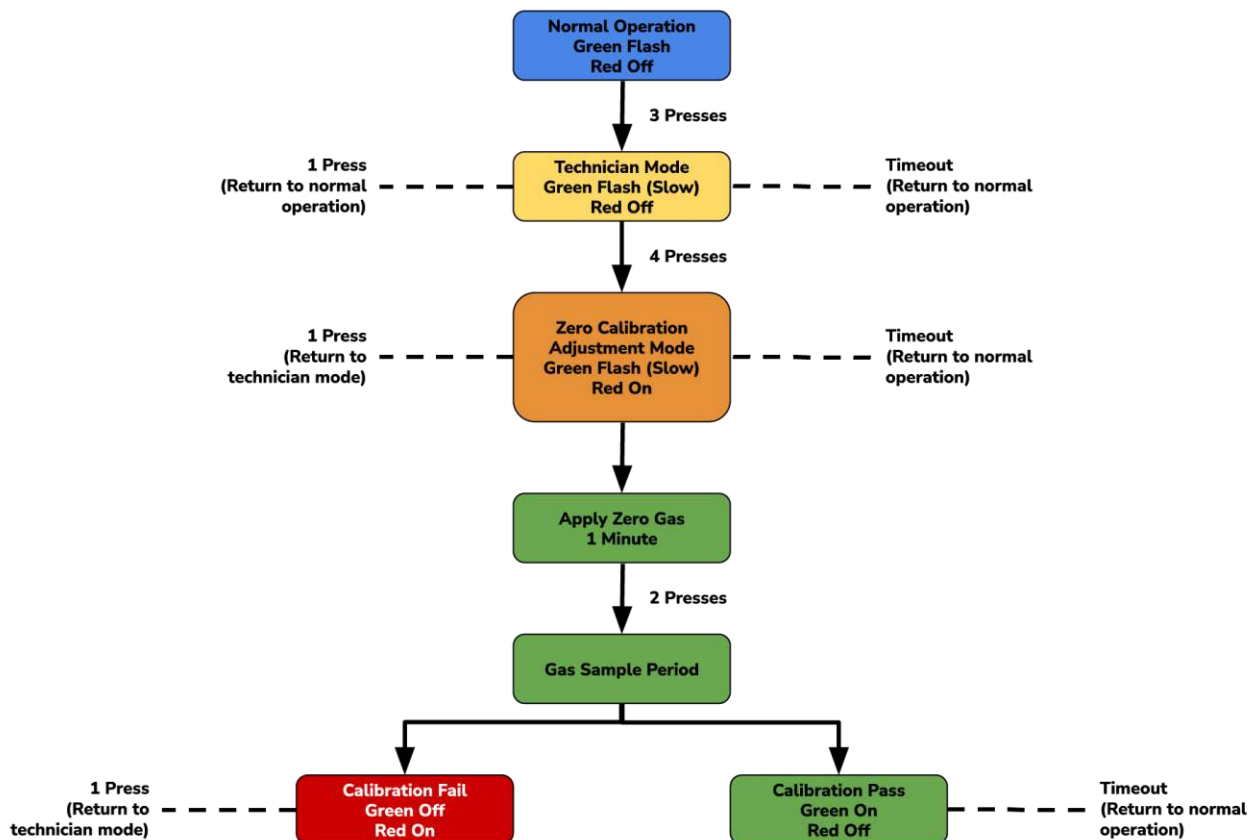

7 Electrochemical sensor replacement

7.1 Replacing a standard O₂ sensor

To replace an exhausted O₂ electrochemical sensor module, a new sensor module (Quick Connect or Direct Connect) should be ordered, contact Analox for further information.

NOTE: **ONCE A NEW O₂ SENSOR MODULE IS FITTED, A FULL CALIBRATION SHOULD BE PERFORMED, SEE SECTION 5 FOR THE RELEVANT SENSOR CALIBRATION PROCEDURE.**

7.2 Replacing a SAFE-OX O₂ cell

- 1] Remove the screws (1) from the lid and remove the lid assembly (2) from the base.

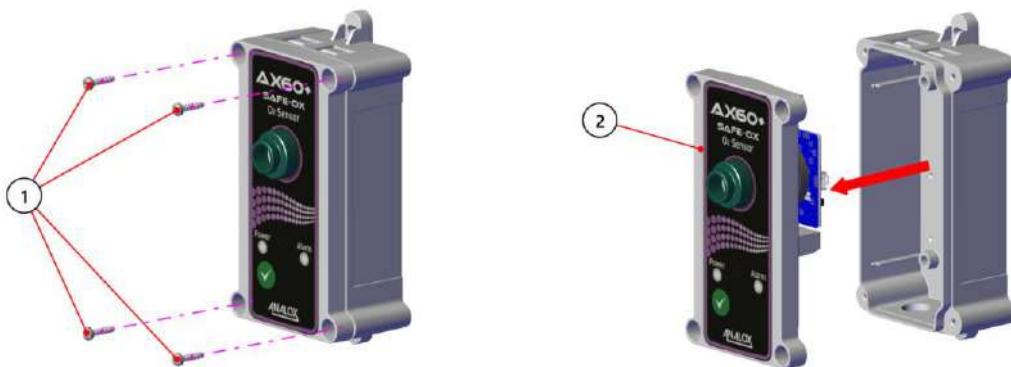

- 2] Remove the connector (3) from the O₂ sensor PCB.

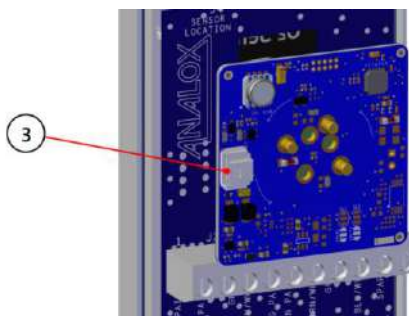

- 3] Rotate the port connector anti clockwise (4) and remove.

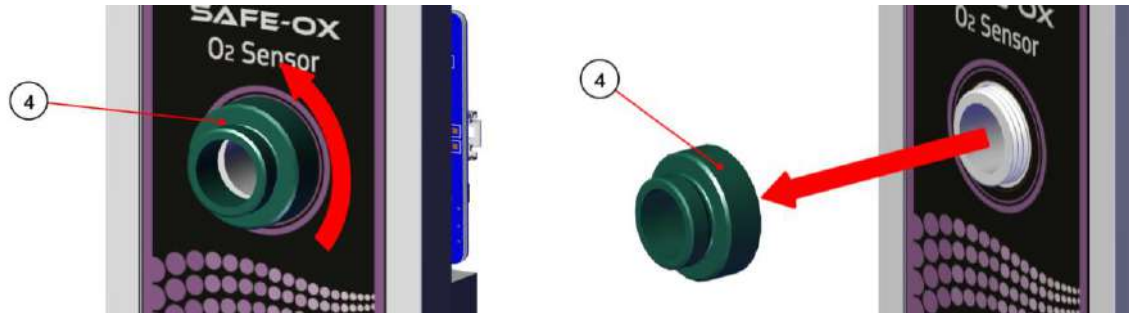

- 4] Remove the O2 cell and PCB assembly (6) from the lid.

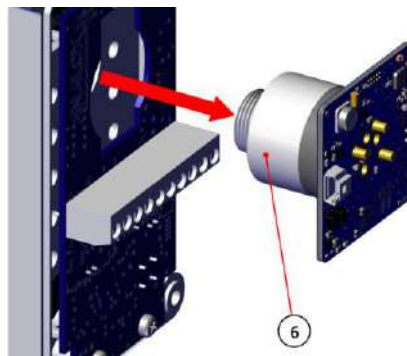

- 5] Remove the O2 cell from the PCB (7).

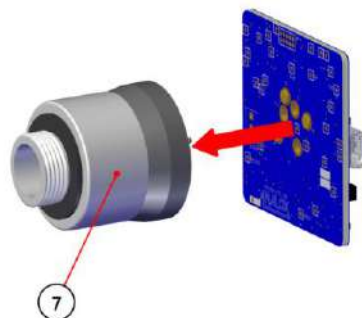

- 6] To fit a new O2 cell, repeat steps 1 to 6 in opposite sequence.

NOTE: **ONCE A NEW O₂ CELL IS FITTED, A FULL CALIBRATION SHOULD BE PERFORMED, SEE SECTION 5 FOR THE RELEVANT SENSOR CALIBRATION PROCEDURE.**

7.3 Replacing a CO cell

- 1] Remove the four M3 x 12mm Pozi Plastech screws securing the lid, remove the lid assembly from the base.



- 2] Disconnect the cable loom from the CO sensor interface PCB.

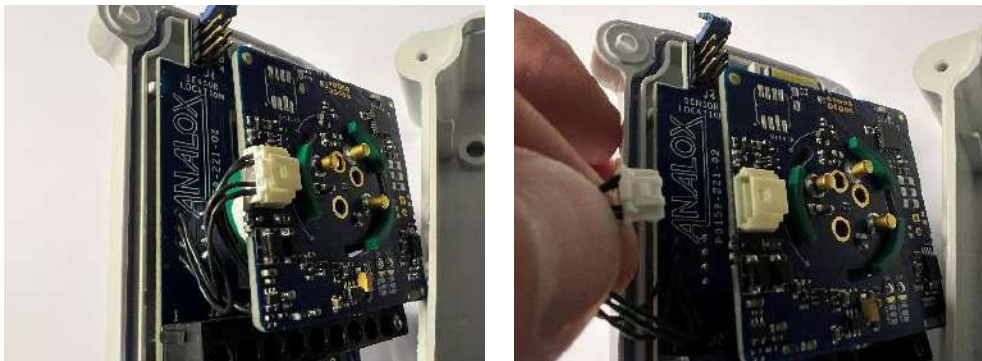

- 3] Rotate the PCB anti-clockwise until the PCB and CO cell can be removed from the housing.



- 4] Pull the CO cell away from the interface PCB.

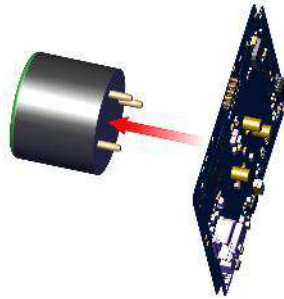

- 5] Fit a new CO cell to the interface PCB (Cell can only be fitted in one orientation).
- 6] Refit the cell and interface PCB to the housing and rotate the PCB clockwise until locked in place.
- 7] Refit the cable loom to the interface PCB and refit the lid assembly to the base, securing in place with the four M3 x 12 Pozi Plastech screws previously removed.

NOTE: **ONCE A NEW CO CELL IS FITTED, A FULL CALIBRATION SHOULD BE PERFORMED, SEE SECTION 5 FOR THE RELEVANT SENSOR CALIBRATION PROCEDURE.**

8 Central Configuration (Displayed as Central Config)

8.1 Attached snrs

The Central Display software is factory configured for a system that has one sensor. If there are two, three, or four sensors the software must be reconfigured. This is done by using the Top-level Menu, Central Config, Attached snrs option.

- 1] Press and hold **Cancel + Cycle** for at least 6 seconds. Then press **Cycle** five times to display **Central Config**.
- 2] Press **Accept/Test** to display the **Attached snrs** screen.
- 3] Press **Accept/Test** again to select the **Num. of sensors?** Screen.
- 4] Press **Cycle** to toggle the number of sensors then press **Accept/Test** to confirm.

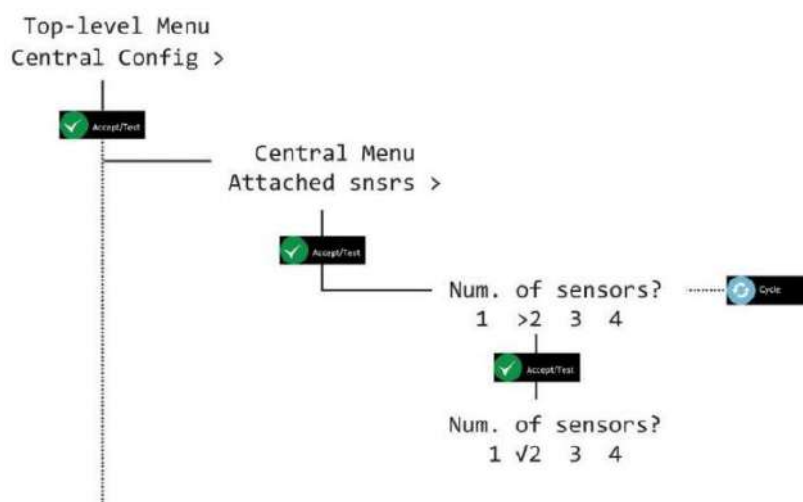
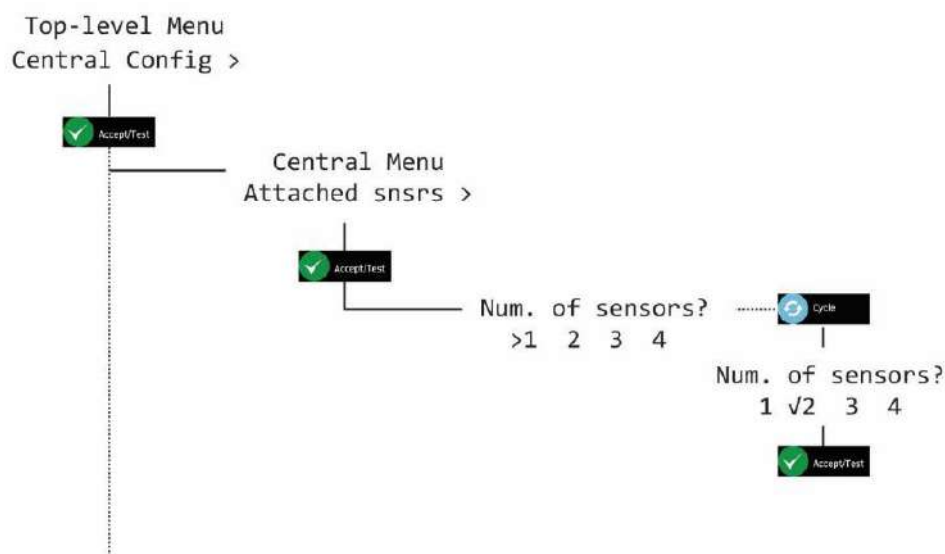

- 5] Press **Cancel** repeatedly to return to **system status** screen.

8.2 Sensor Display Option (Displayed as Snr Display Opt)

- 1] Press and hold **Cancel + Cycle** for at least 6 seconds. Then press **Cycle** five times to display **Central Config**.
- 2] Press **Accept/Test**, then press **Cycle** six times, press **Accept/Test** to display the **Set as Ax60?** Screen.
- 3] Press **Cycle** to toggle Y or N, then press **Accept/Test** to confirm.

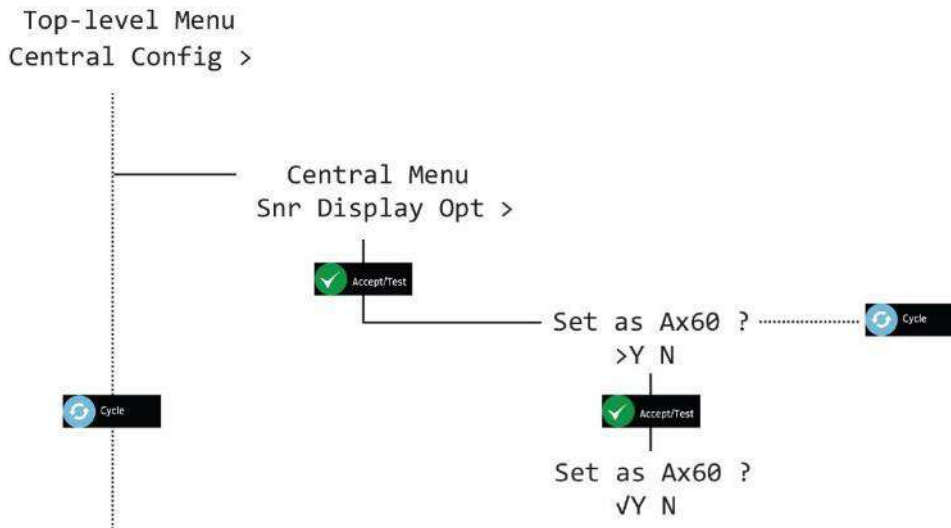

- 4] Press **Cancel** repeatedly to return to **system status** screen.

8.3 Set Evacuation

- 1] Press and hold **Cancel + Cycle** for at least 6 seconds. Then press **Cycle** five times to display **Central Config**.
- 2] Press **Accept/Test**, then press **Cycle** once to display the **Set Evacuation** screen.
- 3] Press **Accept/Test** to display the **Enable Evac ?** screen, press **Cycle** to toggle Y or N, then press **Accept/Test** to confirm.

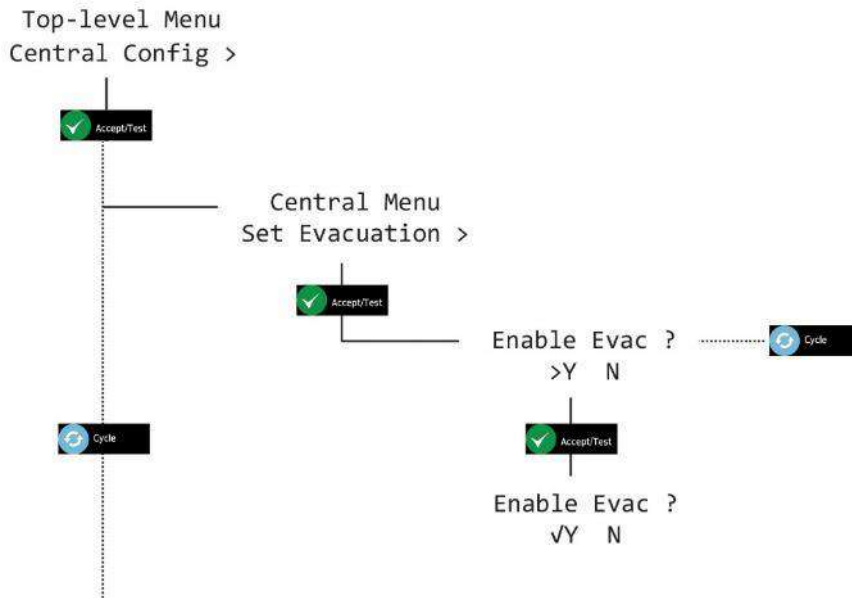

- 4] Press **Cancel** repeatedly to return to **system status** screen.

8.4 Relay configuration

Two relays are installed in the Central Display, R1 and R2. These can be independently configured to be triggered by any alarm or fault raised in the system. The installer is responsible for any connections from R1 and R2 to external devices such as mains relays or control systems.

8.4.1 Fail safe relays

The Ax60+ central unit is fitted with two relays which operate in conjunction with the sensor alarms. The relays have single pole change-over contact arrangements, rated to switch up to 3 Amp at 250V AC/30V DC. The default configuration has the relays set in a Fail-Safe state.

The relays may be configured to be energised or de-energised, when the instrument is in a non-alarm state. If the relays are configured to be in a normally energised state, this will provide a 'Fail-Safe' facility in that a total power failure will cause the relays to release and signal an alarm condition. Contact arrangement is shown on the PCB for a non-Fail-Safe or normally de-energised relay.

8.4.2 Hardware overview

R1 and R2 are single pole double throw (SPDT) rated for 250V AC/30V DC 3A Max. They have volt-free contacts, normally open (NO) or normally closed (NC), to switch external systems such as fire alarms, building management systems or ventilation via an external mains relay.

NOTE: R1 AND R2 PROVIDE VOLT-FREE SWITCH CONTACTS, NOT A POWER SUPPLY.

The connecting cables to Relays 1 and 2 can be installed either through a cable gland (supplied) on the underside of the Central Display or via a knockout on the rear of the enclosure.

Central Display PCB showing the screw terminals for connecting to Relay 1 and Relay 2



Relay 2 Relay 1

WARNING: TO COMPLY WITH THE APPROPRIATE SAFETY STANDARDS, ANY CIRCUITS CONNECTED TO RELAYS 1 AND 2 MUST BE PROTECTED WITH DOUBLE/REINFORCED INSULATION FROM THE MAINS.

8.4.3 Relay 1 fail-safe (Displayed as Rly 1 fail-safe)

- 1] Press and hold **Cancel + Cycle** for at least 6 seconds. Then press **Cycle** five times to display **Central Config**.
- 2] Press **Accept/Test**, then press **Cycle** twice, press **Accept/Test** to display the **Rly 1 fail-safe** screen.
- 3] Press **Cycle** to toggle Y or N, then press **Accept/Test** to confirm.

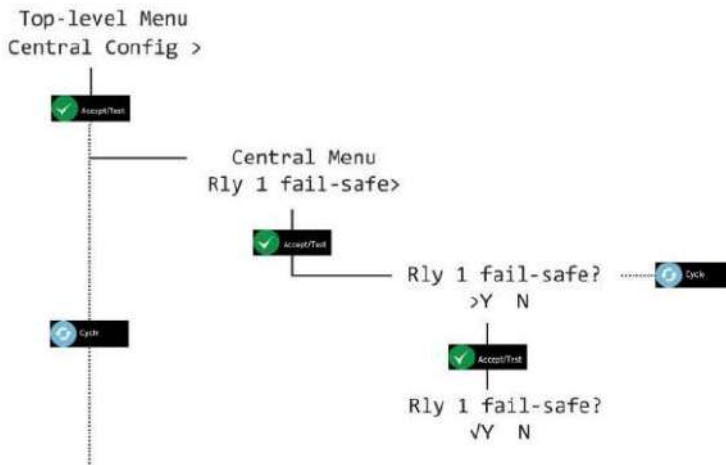

- 4] Press **Cancel** repeatedly to return to **system status** screen

8.4.4 Relay 2 fail-safe (Displayed as Rly 2 fail-safe)

- 1] Press and hold **Cancel + Cycle** for at least 6 seconds. Then press **Cycle** five times to display **Central Config**.
- 2] Press **Accept/Test**, then press **Cycle** three times, press **Accept/Test** to display the **Rly 2 fail-safe** screen.
- 3] Press **Cycle** to toggle Y or N, then press **Accept/Test** to confirm.

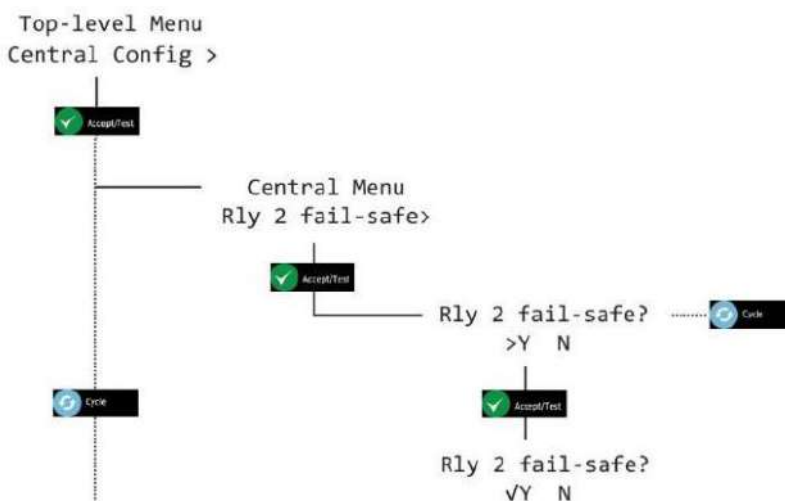

- 4] Press **Cancel** repeatedly to return to **system status** screen.

8.4.5 Relay 1 on fault (Displayed as Rly 1 on fault)

- 1] Press and hold **Cancel + Cycle** for at least 6 seconds. Then press **Cycle** five times to display **Central Config**.
- 2] Press **Accept/Test**, then press **Cycle** four times, press **Accept/Test** to display the **Rly 1 on fault ?** screen.
- 3] Press **Cycle** to toggle Y or N, then press **Accept/Test** to confirm.

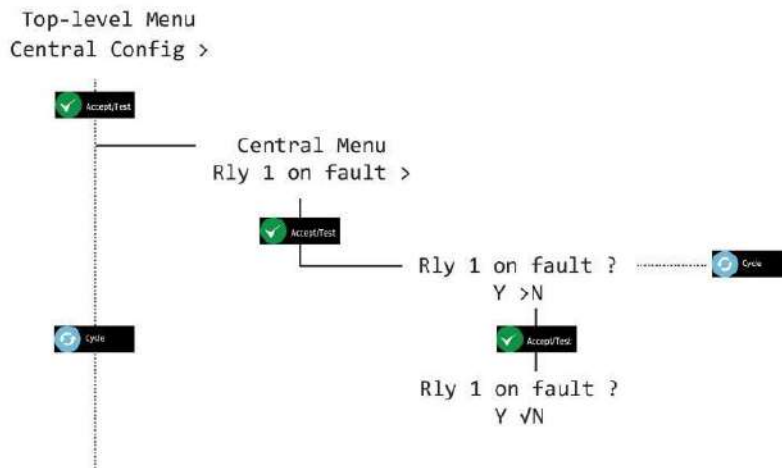

- 4] Press **Cancel** repeatedly to return to **system status** screen

8.4.6 Relay 2 on fault (Displayed as Rly 2 on fault)

- 1] Press and hold **Cancel + Cycle** for at least 6 seconds. Then press **Cycle** five times to display **Central Config**.
- 2] Press **Accept/Test**, then press **Cycle** five times, press **Accept/Test** to display the **Rly 2 on fault ?** screen.
- 3] Press **Cycle** to toggle Y or N, then press **Accept/Test** to confirm.

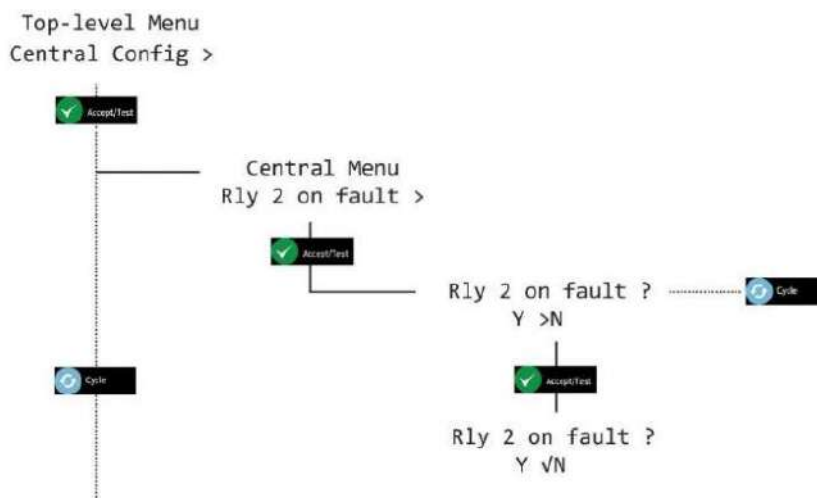

- 4] Press **Cancel** repeatedly to return to **system status** screen.

8.4.7 Relay 1 on alarms (Displayed as Rly 1 on alarms)

- 1] Press and hold **Cancel + Cycle** for at least 6 seconds. Then press **Cycle** five times to display **Central Config**.
- 2] Press **Accept/Test**, then press **Cycle** seven times, press **Accept/Test** to display the **Rly 1 on alarms** option.
- 3] Press **Accept/Test** to display the **Select sensor** screen, press **Cycle** to toggle to chosen sensor, then press **Accept/Test** to display the **Select alarm** screen.
- 4] Press **Cycle** to toggle to chosen alarm, press **Accept/Test** to display the **Set on Alarm** option, press **Cycle** to toggle Y or N, then press **Accept/Test** to confirm.

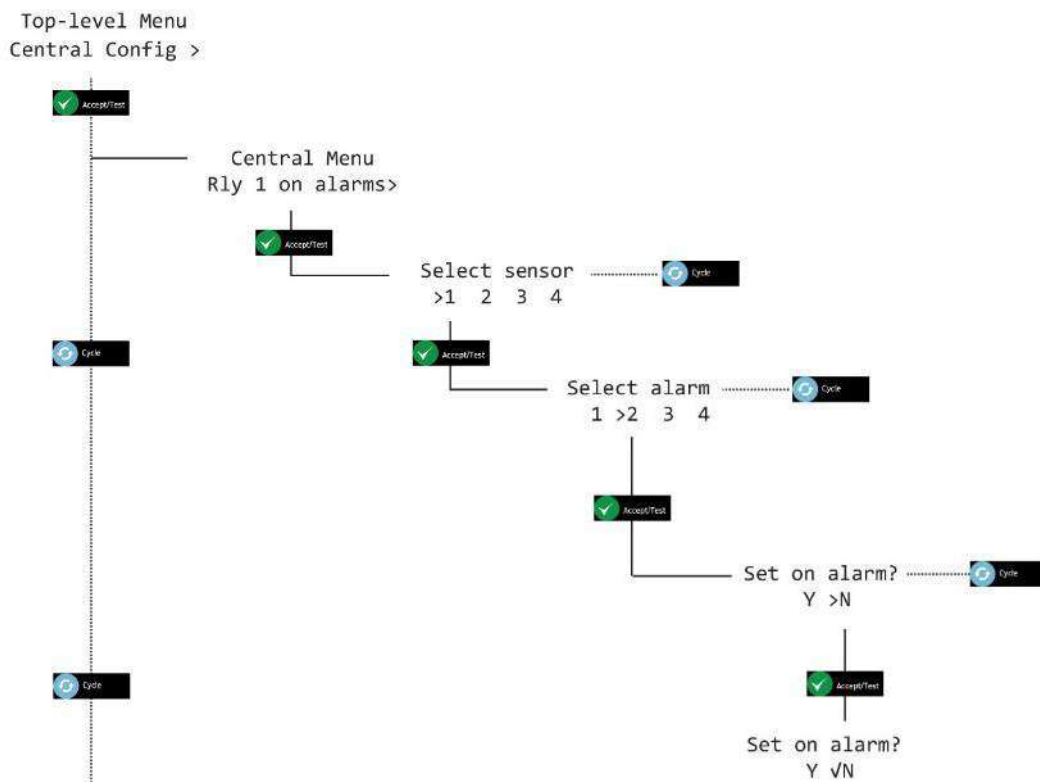

- 5] Press **Cancel** repeatedly to return to **system status** screen.

8.4.8 Relay 2 on alarms (Displayed as Rly 2 on alarms)

- 1] Press and hold **Cancel + Cycle** for at least 6 seconds. Then press **Cycle** five times to display **Central Config**.
- 2] Press **Accept/Test**, then press **Cycle** eight times, press **Accept/Test** to display the **Rly 2 on alarms** option.
- 3] Press **Accept/Test** to display the **Select sensor** screen, press **Cycle** to toggle to chosen sensor, then press **Accept/Test** to display the **Select alarm** screen.
- 4] Press **Cycle** to toggle to chosen alarm, press **Accept/Test** to display the **Set on Alarm** option, press **Cycle** to toggle Y or N, then press **Accept/Test** to confirm.

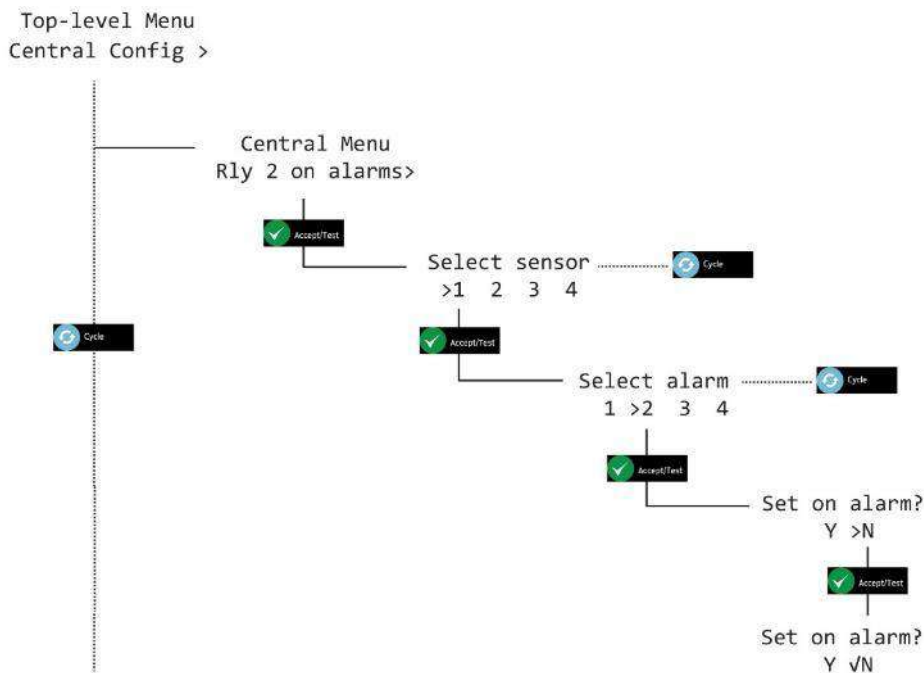

- 5] Press **Cancel** repeatedly to return to **system status** screen.

8.5 Set elevation level

- 1] Press and hold **Cancel + Cycle** for at least 6 seconds. Then press **Cycle** five times to display **Central Config**.
- 2] Press **Accept/Test**, then press Cycle nine times to display Central Menu **Elevation lvl**.
- 3] Press **Accept/Test** to display Elevation level OFF.
- 4] Press **Accept/Test** to display elevation level 82ft 25 m
- 5] Press **Cycle** to increment the elevation level. A single press will increment the elevation level by 25m. Press and hold **Cycle** to increment the elevation level by 100m.
- 6] Press **Accept/Test** to confirm the selected elevation level. This is confirmed by the ✓ symbol.
- 7] Press **Accept/Test** to set the selected elevation level or press **Cycle** to return to elevation level OFF.
- 8] Press **Accept/Test** to set elevation level OFF. This is confirmed by the ✓ symbol.
- 9] Press Accept/Test.

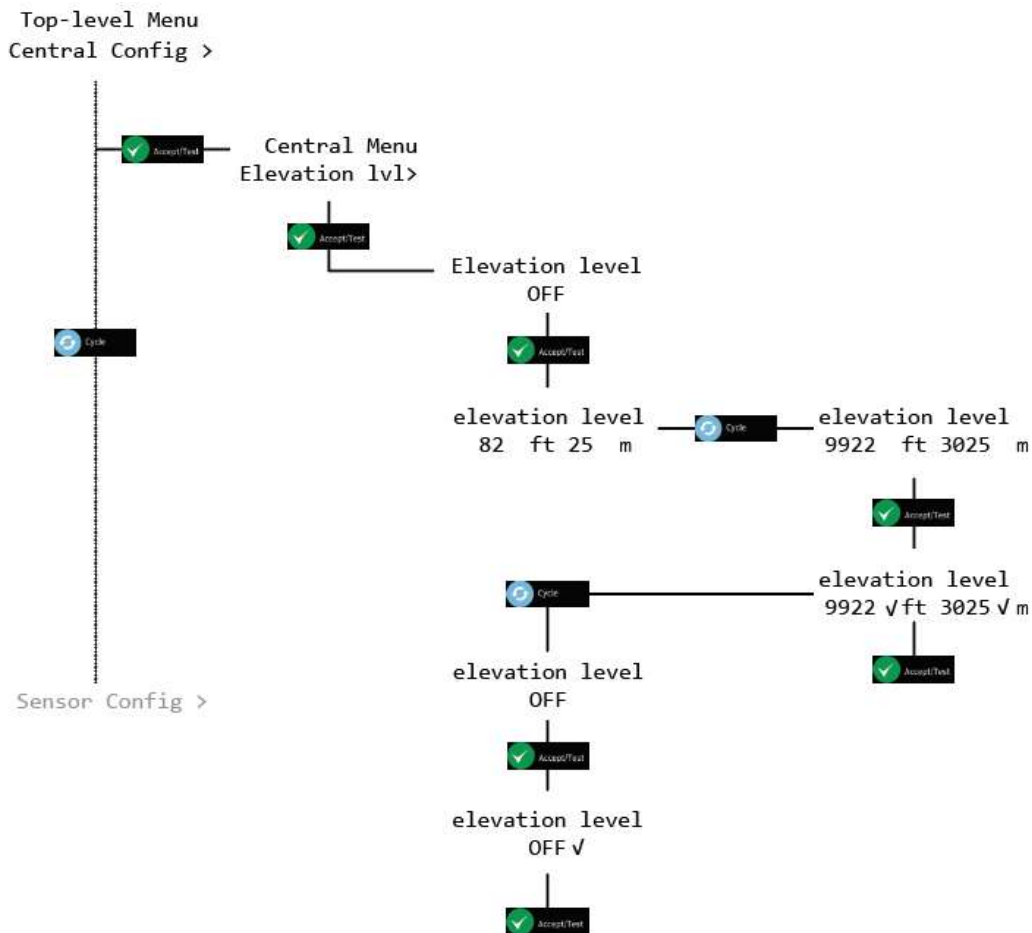

- 10] Press **Cancel** repeatedly to return to **system status** screen.

9 Sensor Configuration (Displayed as Sensor Config)

9.1 Enable alarms

- 1] Press and hold **Cancel + Cycle** for at least 6 seconds. Then press **Cycle** six times to display **Sensor Config**.
- 2] Press **Accept/Test** to display the **Select sensor** screen, press **Cycle** to toggle to chosen sensor, then press **Accept/Test** to display the **Select alarm** screen.
- 3] Press **Cycle** to toggle through the alarms, then press **Accept/Test** display the **Set alarm** screen.
- 4] Press **Cycle** to toggle Y or N, then press **Accept/Test** to confirm.

Top-level Menu
Sensor Config >

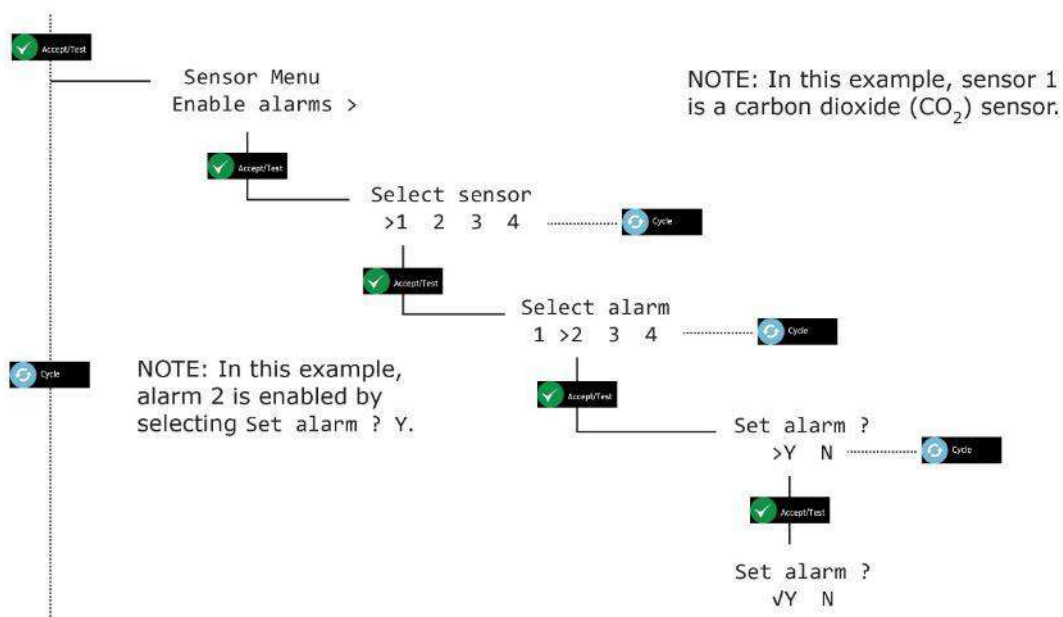

- 5] Press **Cancel** repeatedly to return to **system status** screen.

9.2 Enable Evacuation (Displayed as Enable Evac)

NOTE: TAKE CARE WHEN ADJUSTING SENSOR OPTIONS TO ENSURE THAT SETTINGS ALIGN

- 1] Press and hold **Cancel + Cycle** for at least 6 seconds. Then press **Cycle** six times to display **Sensor Config**.
- 2] Press **Cycle** once to display the **Enable Evac** screen.
- 3] Press **Accept/Test** to display the **Select sensor** screen, press **Cycle** to toggle to chosen sensor, then press **Accept/Test** to display the **Select alarm** screen.
- 4] Press **Cycle** to toggle through the alarms, then press **Accept/Test** to display the **Set Evac** screen, press **Cycle** to toggle Y or N, then press **Accept/Test** to confirm.

Top-level Menu
Sensor Config >

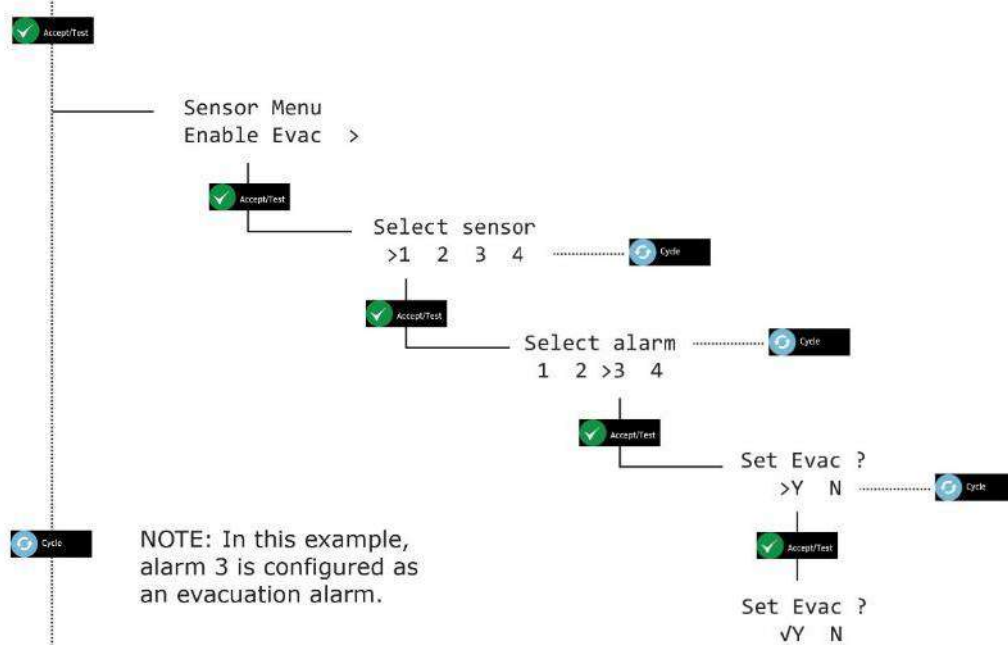

- 5] Press **Cancel** repeatedly to return to **system status** screen.

9.3 Alarm Direction

- 1] Press and hold **Cancel + Cycle** for at least 6 seconds. Then press **Cycle** six times to display **Sensor Config**.
- 2] Press **Cycle** twice to display the **Alarm Direction** screen.
- 3] Press **Accept/Test** to display the **Select sensor** screen, press **Cycle** to toggle to chosen sensor, then press **Accept/Test** to display the **Select alarm** screen.
- 4] Press **Cycle** to toggle through the alarms, then press **Accept/Test** to display the **Alarm direction?** screen, press **Cycle** to toggle ↑ or ↓, then press **Accept/Test** to confirm.

Top-level Menu
Sensor Config >

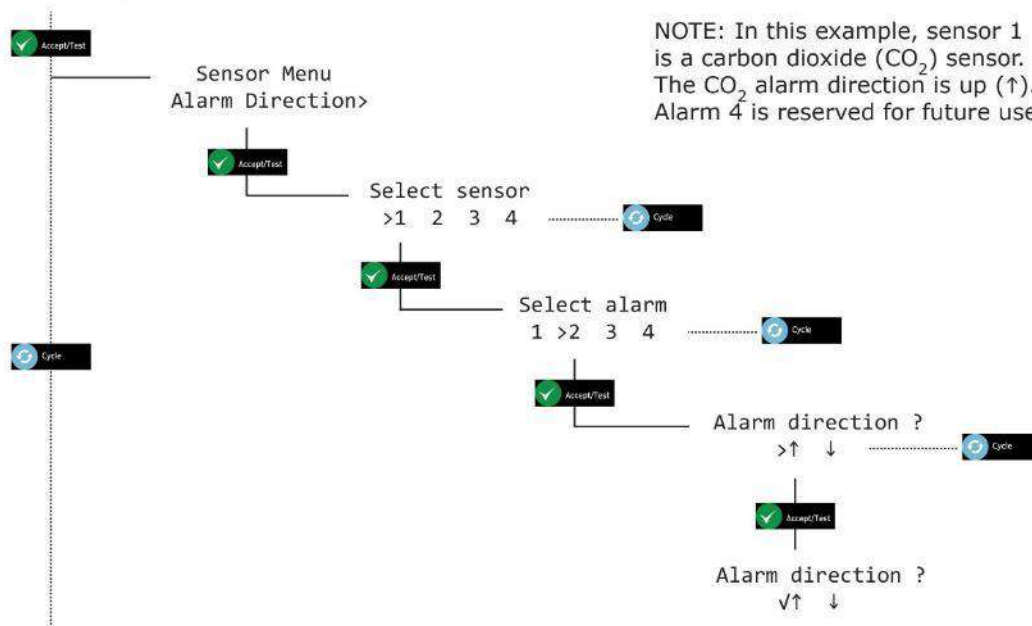

- 5] Press **Cancel** to return Press **Cancel** repeatedly to return to **system status** screen.

9.4 Enable Sounder

- 1] Press and hold **Cancel + Cycle** for at least 6 seconds. Then press **Cycle** six times to display **Sensor Config**.
- 2] Press **Cycle** three times to display the **Enable Sounder** screen.
- 3] Press **Accept/Test** to display the **Select sensor** screen, press **Cycle** to toggle to chosen sensor, then press **Accept/Test** to display the **Select alarm** screen.
- 4] Press **Cycle** to toggle through the alarms, then press **Accept/Test** to display the **Enable Sounder** screen, press **Cycle** to toggle Y or N, then press **Accept/Test** to confirm.

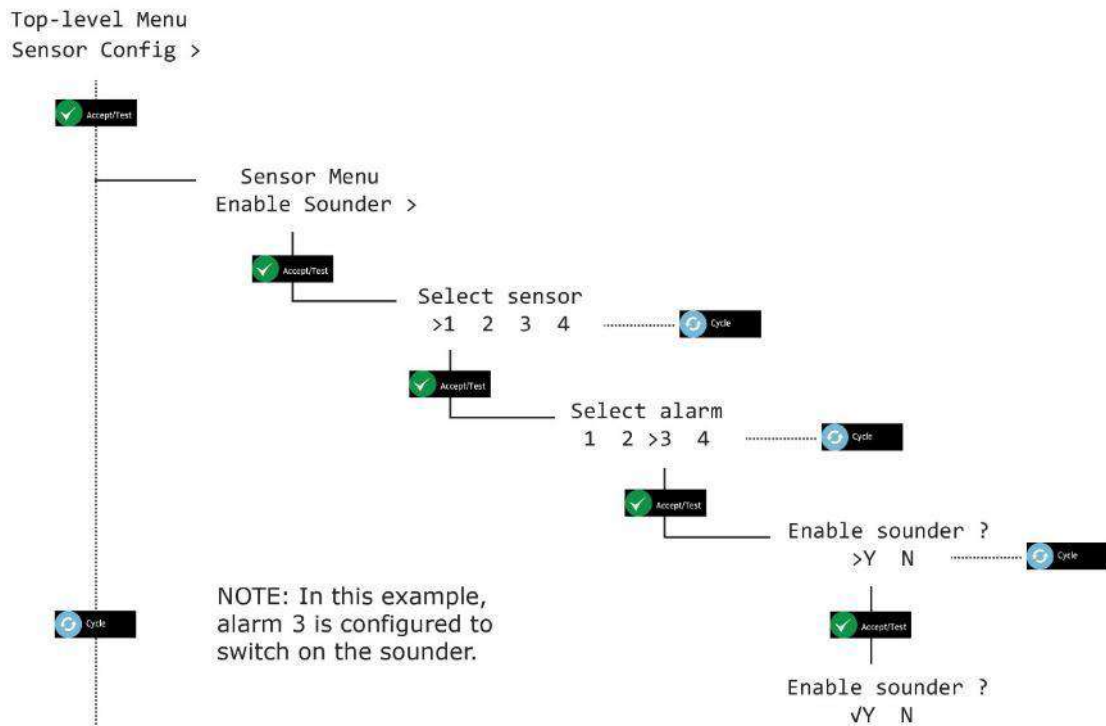

- 5] Press **Cancel** repeatedly to return to **system status** screen.

9.5 Enable Strobe

- 1] Press and hold **Cancel + Cycle** for at least 6 seconds. Then press **Cycle** six times to display **Sensor Config**.
- 2] Press **Cycle** four times to display the **Enable Strobe** screen.
- 3] Press **Accept/Test** to display the **Select sensor** screen, press **Cycle** to toggle to chosen sensor, then press **Accept/Test** to display the **Select alarm** screen.
- 4] Press **Cycle** to toggle through the alarms, then press **Accept/Test** to display the **Enable Strobe** screen, press **Cycle** to toggle Y or N, then press **Accept/Test** to confirm.

Top-level Menu
Sensor Config >

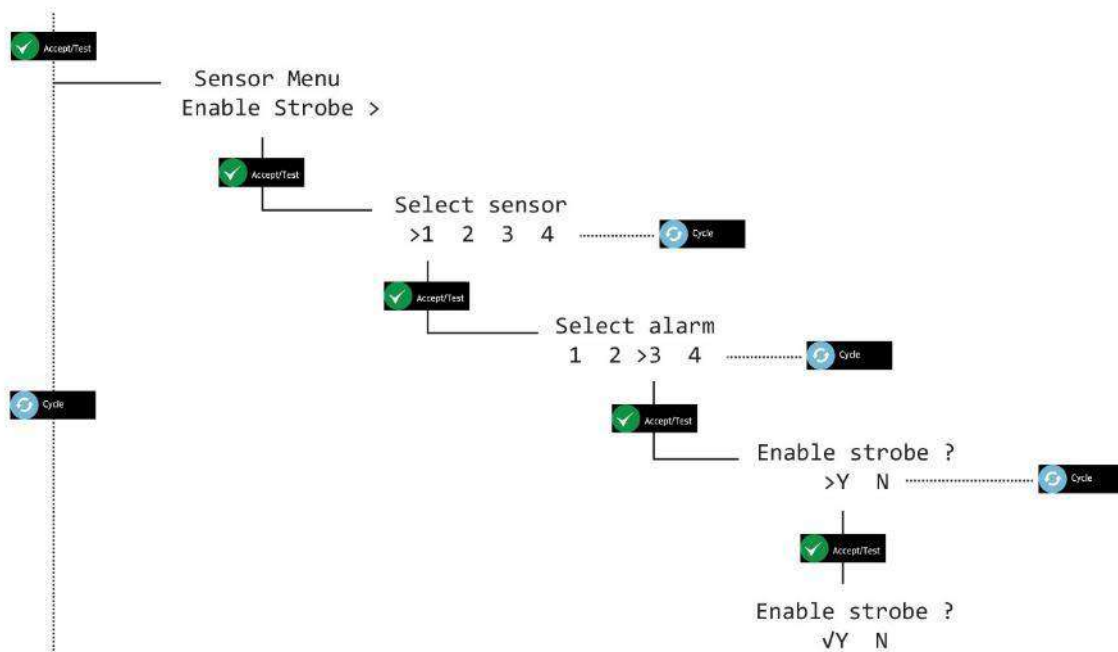

- 5] Press **Cancel** repeatedly to return to **system status** screen.

9.6 Alarms Latching/Non Latching (Displayed as Alarms Latching)

 **NOTE: ALARMS ARE SET BY DEFAULT TO LATCHED**

- 1] Press and hold **Cancel + Cycle** for at least 6 seconds. Then press **Cycle** six times to display **Sensor Config**.
- 2] Press **Cycle** five times to display the **Alarms Latching** screen.
- 3] Press **Accept/Test** to display the **Select sensor** screen, press **Cycle** to toggle to chosen sensor, then press **Accept/Test** to display the **Select alarm** screen.
- 4] Press **Cycle** to toggle through the alarms, then press **Accept/Test** to display the **Alarm Latching** screen, press **Cycle** to toggle Y or N, then press **Accept/Test** to confirm.

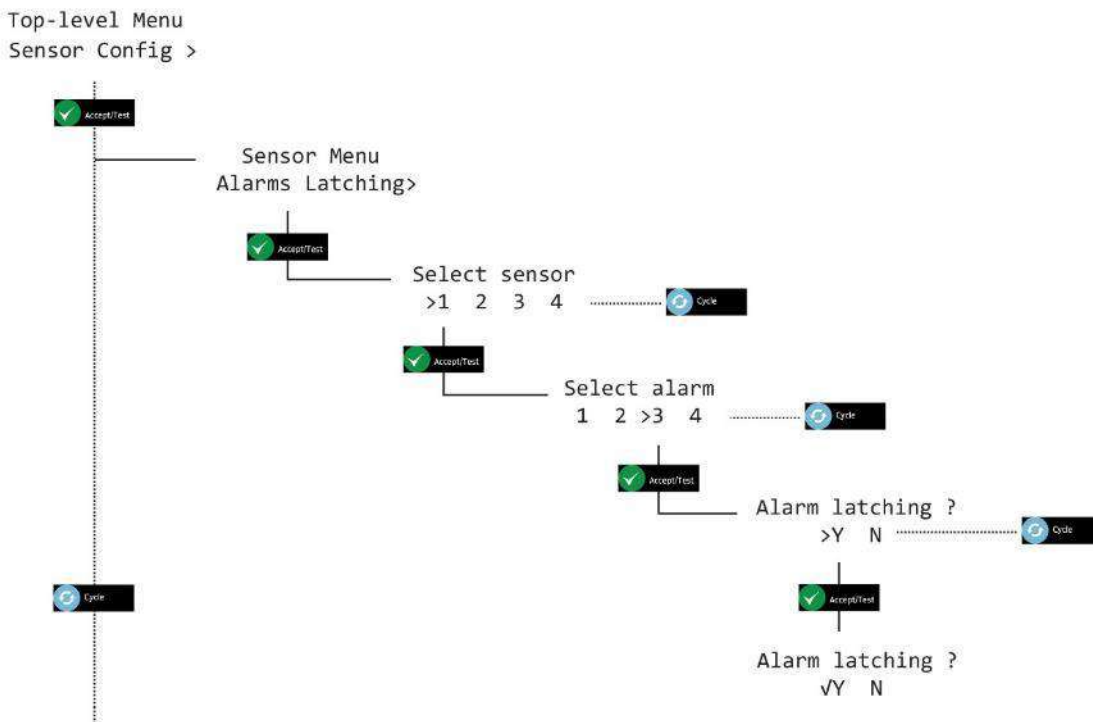

- 5] Press **Cancel** repeatedly to return to **system status** screen.

9.7 Alarm set-points (Displayed as Alarm set-pnts)

⚠ **CAUTION: ALARMS ARE LATCHING. THIS MEANS THE SENSORS ALWAYS REMEMBER THEIR CURRENT ALARM STATE, EVEN AFTER A POWER OUTAGE. FOR EXAMPLE, IF A SENSOR IS EXPOSED TO 3% CO₂ BUT THE ALARM IS NOT ACKNOWLEDGED AND THE POWER IS REMOVED, WHEN POWER IS RESTORED, IT GOES STRAIGHT INTO ALARM.**

⚠ **CAUTION: DEFAULT ALARM LEVELS SHOULD BE CHANGED ONLY BY AN AUTHORISED AX60+ INSTALLER OR SERVICE ENGINEER.**

📌 **NOTE: ALARM LEVELS ARE STORED IN EACH SENSOR UNIT, THESE WILL NEED TO BE SET AT SENSOR INSTALLATION IF THE REQUIRED LEVELS DIFFER FROM DEFAULT.**

- 1] Press and hold **Cancel + Cycle** for at least 6 seconds. Then press **Cycle** six times to display **Sensor Config**.
- 2] Standard increments for alarm setpoints is factory set at 0.10 %, however, by pressing and holding the **Cycle** button this increases the increment value x 10 (1.00 %).
- 3] Press **Cycle** six times to display the **Alarm set-pnts** screen.
- 4] Press **Accept/Test** to display the **Select sensor** screen, press **Cycle** to toggle to chosen sensor, then press **Accept/Test** to display the **Select alarm** screen.
- 5] Press **Cycle** to toggle through the alarms, then press **Accept/Test** to display the **Set alarm AL?** screen (Where ? could be AL1, AL2, AL3 or AL4).
- 6] Press **Cycle** repeatedly to enter the alarm value you want in 0.10% increments or press and hold **Cycle** to increase the value at 1.00% increments.
- 7] To reset the value and start again, repeatedly press **Cycle** or press and hold **Cycle** until you exceed 6.00 %, this will take the value back to 0.00 % and you can cycle through again until you reach the required value.
- 8] Press **Accept/Test** to accept the alarm set point.

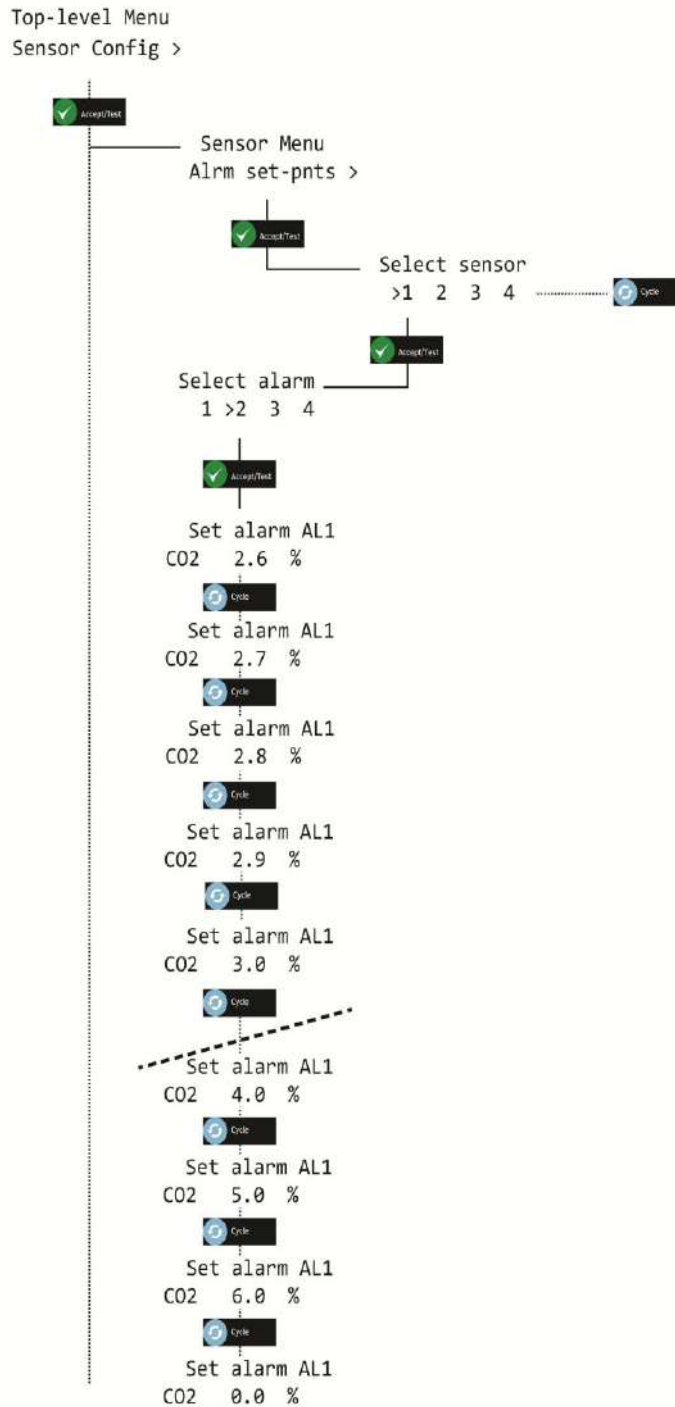

9] Press **Cancel** repeatedly to return to **system status** screen.

10 Ax60+ Kiosk Option

The Ax60+ Kiosk can be serviced in the same way as the standard Ax60+ by temporarily fitting a portable calibration unit (part no. AX60CNQNXA). This is supplied with a pre-fitted cable terminating in an RJ45 plug, an RJ45 cable coupler and a length of cable:



AX60CNQNXA portable calibration unit

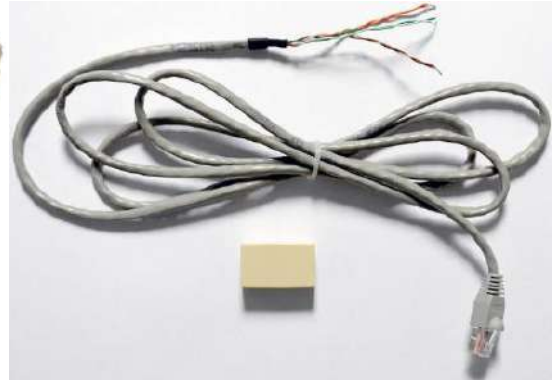

AX60CNQXA temporary cable and coupler

To connect the AX60CNQNXA calibration unit to the Ax60+ Kiosk Sensor, follow this procedure:

⚠ WARNING: DISCONNECT AND ISOLATE THE AX60+ KIOSK FROM THE MAINS POWER SUPPLY BEFORE OPENING THE CO₂ SENSOR ENCLOSURE.

- 1] Remove the front cover from the Ax60+ Kiosk Sensor enclosure.



- 2] Install the temporary cable through the cable gland and connect as follows:



- ORG PAIR (temporary cable); Black (existing cable)**
- BRN PAIR (temporary cable); Black (existing cable)**
- GRN (temporary cable)**
- GRN/WHT (temporary cable)**
- ORG PAIR (existing cable)**
- BRN PAIR (existing cable)**
- GRN/WHT (existing cable)**
- GRN (existing cable)**
- BLU/WHT (existing cable)**
- SPARE (not used)**

- 3] Replace the front cover on the Ax60+ Kiosk Sensor enclosure.
- 4] Reconnect the mains supply and power-up the Ax60+ Kiosk.

11 Fault finding

11.1 Fault codes

Faults are announced by the Central Display as follows:

- the internal buzzer will sound
- the Fault indicator will flash
- the fault code will display (see below)
-

Fault type	Fault code	Description	Action
Communications fault	COMMS FAULT	Sensor has a communications fault	May be caused by accidental cable disconnection. To clear a COMMS FAULT press Accept/Test to silence the buzzer then reconnect the cable. Other faults must be reported to Analox
Sensor fault	FLT02 - FLT11, FLT14, FLT15, FLT17, FLT32	The sensor unit is in fault	<ol style="list-style-type: none"> 1. Acknowledge the Fault 2. Power cycle the device
	FLT12 - FLT13, FLT16, FLT23 - FLT24	Calibration required	<ol style="list-style-type: none"> 1. Carry out a zero and span calibration
	FLT31	Sensor unit button fault (only applicable to the Ax60k)	<ol style="list-style-type: none"> 1. Acknowledge the fault 2. Check for correct operation of the sensor unit button 3. Power cycle the device
Central Display fault	FLT51 - FLT55	Central Display unit is in fault	<ol style="list-style-type: none"> 1. Acknowledge the Fault 2. Power cycle the device

11.2 Data Output Module fault indication

The DOM indicates its internal operating condition in one of three ways:

- 1) By its Status and Fault LEDs (see below).
- 2) By setting all of the 4-20mA channels to indicate a fault condition.
- 3) By setting Modbus registers which can be read via the Modbus interface (See Appendix D for more information).

11.2.1 Status and Fault LEDs

The table below shows the combination of LEDs which indicate a specific operating condition:

Status LED	Fault LED	Meaning
Flashing	Off	Normal operation
On	Flashing	Critical Fault (see below)
Off	Flashing	Fault (see below)
On	On	Warm-up (30 seconds)

A Critical Fault is:

- An error has occurred with the internal storage memory of the unit and needs replacing.

A Fault can be one of the following:

- The unit is not receiving data from the Ax60+ system. Check the cabling.
- The unit has not received valid data from the Ax60+ system. Check the cabling and / or power cycle the system.
- If connected to a BMS, an invalid message has been received over the Modbus interface. Check the cabling.
- An internal error has occurred with the unit and will it have to be replaced.

12 Appendix A – Default Central Unit configuration settings

The following table shows the configurable items that can be changed in the Central Unit software menus

Item	Default setting	Comment
Global Evacuation mode	Evacuate	Each alarm has its own evacuation mode.
Number of attached sensors	1	A COMMS fault will occur if the correct number of sensors have not been attached.
Relay fail-safe mode	Fail-safe	Default applies to both relays, but each can be set independently

13 Appendix B – Default CO₂ sensor configuration settings

The following table shows the configurable items that can be changed in the CO₂ Sensor software menus.

Item	Default setting	Comment
Alarm One Enabled	TRUE	Enable alarm
Alarm One Set-point	0.50%	Threshold for the alarm
Alarm One Direction	Hi going	Can be set to either low going or high going
Alarm One Strobe Enable	Off	Activates the strobe on alarm
Alarm One Sounder Enable	Off	Activates the sounder on alarm
Alarm One Evacuation Enabled	Off	Activates the strobe and sounder of connected sensors on alarm
Alarm One Latching Enable	On	Requires the user to mute and acknowledge the alarm before the alarm will clear
Alarm Two Enabled	TRUE	Enable alarm
Alarm Two Set-point	1.50%	Threshold for the alarm
Alarm Two Direction	Hi going	Can be set to either low going or high going
Alarm Two Strobe Enable	On	Activates the strobe on alarm
Alarm Two Sounder Enable	Off	Activates the sounder on alarm
Alarm Two Evacuation Enabled	Off	Activates the strobe and sounder of connected sensors on alarm
Alarm Two Latching Enable	On	Requires the user to mute and acknowledge the alarm before the alarm will clear
Alarm Three Enabled	TRUE	Enable alarm
Alarm Three Set-point	3.00%	Threshold for the alarm
Alarm Three Direction	Hi going	Can be set to either low going or high going
Alarm Three Strobe Enable	On	Activates the strobe on alarm
Alarm Three Sounder Enable	On	Activates the sounder on alarm
Alarm Three Evacuation Enabled	On	Activates the strobe and sounder of connected sensors on alarm
Alarm Three Latching Enable	On	Requires the user to mute and acknowledge the alarm before the alarm will clear
Alarm Four Enabled	FALSE	Enable alarm
Alarm Four Set-point	3.50%	Threshold for the alarm
Alarm Four Direction	Hi going	Can be set to either low going or high going
Alarm Four Strobe Enable	Off	Activates the strobe on alarm
Alarm Four Sounder Enable	Off	Activates the sounder on alarm
Alarm Four Evacuation Enabled	Off	Activates the strobe and sounder of connected sensors on alarm
Alarm Four Latching Enable	On	Requires the user to mute and acknowledge the alarm before the alarm will clear

14 Appendix C – US IFC CO₂ sensor configuration settings

The following table shows the configurable items that can be changed in the CO₂ Sensor software menus.

Item	Default setting	Comment
Alarm One Enabled	TRUE	Enable alarm
Alarm One Set-point	0.50%	Threshold for the alarm
Alarm One Direction	Hi going	Can be set to either low going or high going
Alarm One Strobe Enable	Off	Activates the strobe on alarm
Alarm One Sounder Enable	Off	Activates the sounder on alarm
Alarm One Evacuation Enabled	Off	Activates the strobe and sounder of connected sensors on alarm
Alarm One Latching Enable	Off	Does not require the user to mute and acknowledge the alarm before the alarm will clear
Alarm Two Enabled	TRUE	Enable alarm
Alarm Two Set-point	0.50%	Threshold for the alarm
Alarm Two Direction	Hi going	Can be set to either low going or high going
Alarm Two Strobe Enable	On	Activates the strobe on alarm
Alarm Two Sounder Enable	On	Activates the sounder on alarm
Alarm Two Evacuation Enabled	Off	Activates the strobe and sounder of connected sensors on alarm
Alarm Two Latching Enable	Off	Does not require the user to mute and acknowledge the alarm before the alarm will clear
Alarm Three Enabled	TRUE	Enable alarm
Alarm Three Set-point	1.50%	Threshold for the alarm
Alarm Three Direction	Hi going	Can be set to either low going or high going
Alarm Three Strobe Enable	On	Activates the strobe on alarm
Alarm Three Sounder Enable	On	Activates the sounder on alarm
Alarm Three Evacuation Enabled	Off	Activates the strobe and sounder of connected sensors on alarm
Alarm Three Latching Enable	Off	Does not require the user to mute and acknowledge the alarm before the alarm will clear
Alarm Four Enabled	FALSE	Enable alarm
Alarm Four Set-point	3.00%	Threshold for the alarm
Alarm Four Direction	Hi going	Can be set to either low going or high going
Alarm Four Strobe Enable	On	Activates the strobe on alarm
Alarm Four Sounder Enable	On	Activates the sounder on alarm
Alarm Four Evacuation Enabled	On	Activates the strobe and sounder of connected sensors on alarm
Alarm Four Latching Enable	Off	Does not require the user to mute and acknowledge the alarm before the alarm will clear

15 Appendix D – Default Kiosk CO₂ sensor configuration settings

The following table shows the configurable items that can be changed in the CO₂ Sensor software menus.

Item	Default setting	Comment
Alarm One Enabled	TRUE	Enable alarm
Alarm One Set-point	0.50%	Threshold for the alarm
Alarm One Direction	Hi going	Can be set to either low going or high going
Alarm One Strobe Enable	Off	Activates the strobe on alarm
Alarm One Sounder Enable	Off	Activates the sounder on alarm
Alarm One Evacuation Enabled	Off	Activates the strobe and sounder of connected sensors on alarm
Alarm One Latching Enable	Off	Does not require the user to mute and acknowledge the alarm before the alarm will clear
Alarm Two Enabled	TRUE	Enable alarm
Alarm Two Set-point	1.50%	Threshold for the alarm
Alarm Two Direction	Hi going	Can be set to either low going or high going
Alarm Two Strobe Enable	On	Activates the strobe on alarm
Alarm Two Sounder Enable	Off	Activates the sounder on alarm
Alarm Two Evacuation Enabled	Off	Activates the strobe and sounder of connected sensors on alarm
Alarm Two Latching Enable	Off	Does not require the user to mute and acknowledge the alarm before the alarm will clear
Alarm Three Enabled	TRUE	Enable alarm
Alarm Three Set-point	3.00%	Threshold for the alarm
Alarm Three Direction	Hi going	Can be set to either low going or high going
Alarm Three Strobe Enable	On	Activates the strobe on alarm
Alarm Three Sounder Enable	On	Activates the sounder on alarm
Alarm Three Evacuation Enabled	On	Activates the strobe and sounder of connected sensors on alarm
Alarm Three Latching Enable	Off	Does not require the user to mute and acknowledge the alarm before the alarm will clear
Alarm Four Enabled	FALSE	Enable alarm
Alarm Four Set-point	3.50%	Threshold for the alarm
Alarm Four Direction	Hi going	Can be set to either low going or high going
Alarm Four Strobe Enable	Off	Activates the strobe on alarm
Alarm Four Sounder Enable	Off	Activates the sounder on alarm
Alarm Four Evacuation Enabled	Off	Activates the strobe and sounder of connected sensors on alarm
Alarm Four Latching Enable	Off	Does not require the user to mute and acknowledge the alarm before the alarm will clear

16 Appendix E – US IFC Kiosk CO₂ sensor configuration settings

The following table shows the configurable items that can be changed in the CO₂ Sensor software menus.

Item	Default setting	Comment
Alarm One Enabled	TRUE	Enable alarm
Alarm One Set-point	0.50%	Threshold for the alarm
Alarm One Direction	Hi going	Can be set to either low going or high going
Alarm One Strobe Enable	FALSE	Activates the strobe on alarm
Alarm One Sounder Enable	Off	Activates the sounder on alarm
Alarm One Evacuation Enabled	Off	Activates the strobe and sounder of connected sensors on alarm
Alarm One Latching Enable	Off	Does not require the user to mute and acknowledge the alarm before the alarm will clear
Alarm Two Enabled	TRUE	Enable alarm
Alarm Two Set-point	0.50%	Threshold for the alarm
Alarm Two Direction	Hi going	Can be set to either low going or high going
Alarm Two Strobe Enable	On	Activates the strobe on alarm
Alarm Two Sounder Enable	On	Activates the sounder on alarm
Alarm Two Evacuation Enabled	Off	Activates the strobe and sounder of connected sensors on alarm
Alarm Two Latching Enable	Off	Does not require the user to mute and acknowledge the alarm before the alarm will clear
Alarm Three Enabled	TRUE	Enable alarm
Alarm Three Set-point	1.50%	Threshold for the alarm
Alarm Three Direction	Hi going	Can be set to either low going or high going
Alarm Three Strobe Enable	On	Activates the strobe on alarm
Alarm Three Sounder Enable	On	Activates the sounder on alarm
Alarm Three Evacuation Enabled	Off	Activates the strobe and sounder of connected sensors on alarm
Alarm Three Latching Enable	Off	Does not require the user to mute and acknowledge the alarm before the alarm will clear
Alarm Four Enabled	FALSE	Enable alarm
Alarm Four Set-point	3.00%	Threshold for the alarm
Alarm Four Direction	Hi going	Can be set to either low going or high going
Alarm Four Strobe Enable	On	Activates the strobe on alarm
Alarm Four Sounder Enable	On	Activates the sounder on alarm
Alarm Four Evacuation Enabled	On	Activates the strobe and sounder of connected sensors on alarm
Alarm Four Latching Enable	Off	Does not require the user to mute and acknowledge the alarm before the alarm will clear

17 Appendix F – Default O₂ sensor configuration settings

The following table shows the configurable items that can be changed in the O₂ Sensor software menus.

Item	Default setting	Comment
Alarm One Enabled	FALSE	Enable alarm
Alarm One Set-point	19.50%	Threshold for the alarm
Alarm One Direction	Low Going	Can be set to either low going or high going
Alarm One Strobe Enable	Off	Activates the strobe on alarm
Alarm One Sounder Enable	Off	Activates the sounder on alarm
Alarm One Evacuation Enabled	Off	Activates the strobe and sounder of connected sensors on alarm
Alarm One Latching Enable	Off	Requires the user to mute and acknowledge the alarm before the alarm will clear
Alarm Two Enabled	TRUE	Enable alarm
Alarm Two Set-point	19.50%	Threshold for the alarm
Alarm Two Direction	Low Going	Can be set to either low going or high going
Alarm Two Strobe Enable	On	Activates the strobe on alarm
Alarm Two Sounder Enable	Off	Activates the sounder on alarm
Alarm Two Evacuation Enabled	Off	Activates the strobe and sounder of connected sensors on alarm
Alarm Two Latching Enable	Off	Requires the user to mute and acknowledge the alarm before the alarm will clear
Alarm Three Enabled	TRUE	Enable alarm
Alarm Three Set-point	23.00%	Threshold for the alarm
Alarm Three Direction	High Going	Can be set to either low going or high going
Alarm Three Strobe Enable	On	Activates the strobe on alarm
Alarm Three Sounder Enable	On	Activates the sounder on alarm
Alarm Three Evacuation Enabled	FALSE	Activates the strobe and sounder of connected sensors on alarm
Alarm Three Latching Enable	Off	Requires the user to mute and acknowledge the alarm before the alarm will clear
Alarm Four Enabled	TRUE	Enable alarm
Alarm Four Set-point	18.00%	Threshold for the alarm
Alarm Four Direction	Low Going	Can be set to either low going or high going
Alarm Four Strobe Enable	On	Activates the strobe on alarm
Alarm Four Sounder Enable	On	Activates the sounder on alarm
Alarm Four Evacuation Enabled	Off	Activates the strobe and sounder of connected sensors on alarm
Alarm Four Latching Enable	Off	Requires the user to mute and acknowledge the alarm before the alarm will clear

18 Appendix G – US IFC O₂ sensor configuration settings

The following table shows the configurable items that can be changed in the O₂ Sensor software menus.

Item	Default setting	Comment
Alarm One Enabled	FALSE	Enable alarm
Alarm One Set-point	19.50%	Threshold for the alarm
Alarm One Direction	Low Going	Can be set to either low going or high going
Alarm One Strobe Enable	Off	Activates the strobe on alarm
Alarm One Sounder Enable	Off	Activates the sounder on alarm
Alarm One Evacuation Enabled	Off	Activates the strobe and sounder of connected sensors on alarm
Alarm One Latching Enable	Off	Does not require the user to mute and acknowledge the alarm before the alarm will clear
Alarm Two Enabled	TRUE	Enable alarm
Alarm Two Set-point	19.50%	Threshold for the alarm
Alarm Two Direction	Low Going	Can be set to either low going or high going
Alarm Two Strobe Enable	On	Activates the strobe on alarm
Alarm Two Sounder Enable	Off	Activates the sounder on alarm
Alarm Two Evacuation Enabled	Off	Activates the strobe and sounder of connected sensors on alarm
Alarm Two Latching Enable	Off	Does not require the user to mute and acknowledge the alarm before the alarm will clear
Alarm Three Enabled	TRUE	Enable alarm
Alarm Three Set-point	23.00%	Threshold for the alarm
Alarm Three Direction	High Going	Can be set to either low going or high going
Alarm Three Strobe Enable	On	Activates the strobe on alarm
Alarm Three Sounder Enable	On	Activates the sounder on alarm
Alarm Three Evacuation Enabled	Off	Activates the strobe and sounder of connected sensors on alarm
Alarm Three Latching Enable	Off	Does not require the user to mute and acknowledge the alarm before the alarm will clear
Alarm Four Enabled	TRUE	Enable alarm
Alarm Four Set-point	18.00%	Threshold for the alarm
Alarm Four Direction	Low Going	Can be set to either low going or high going
Alarm Four Strobe Enable	On	Activates the strobe on alarm
Alarm Four Sounder Enable	On	Activates the sounder on alarm
Alarm Four Evacuation Enabled	Off	Activates the strobe and sounder of connected sensors on alarm
Alarm Four Latching Enable	Off	Does not require the user to mute and acknowledge the alarm before the alarm will clear

19 Appendix H – Default CO sensor configuration settings

The following table shows the configurable items that can be changed in the CO Sensor software menus.

Item	Default setting	Comment
Alarm One Enabled	FALSE	Enable alarm
Alarm One Set-point	N/A	Threshold for the alarm
Alarm One Direction	Hi going	Can be set to either low going or high going
Alarm One Strobe Enable	Off	Activates the strobe on alarm
Alarm One Sounder Enable	Off	Activates the sounder on alarm
Alarm One Evacuation Enabled	Off	Activates the strobe and sounder of connected sensors on alarm
Alarm One Latching Enable	Off	Requires the user to mute and acknowledge the alarm before the alarm will clear
Alarm Two Enabled	TRUE	Enable alarm
Alarm Two Set-point	3ppm	Threshold for the alarm
Alarm Two Direction	Hi going	Can be set to either low going or high going
Alarm Two Strobe Enable	On	Activates the strobe on alarm
Alarm Two Sounder Enable	Off	Activates the sounder on alarm
Alarm Two Evacuation Enabled	Off	Activates the strobe and sounder of connected sensors on alarm
Alarm Two Latching Enable	Off	Requires the user to mute and acknowledge the alarm before the alarm will clear
Alarm Three Enabled	TRUE	Enable alarm
Alarm Three Set-point	5ppm	Threshold for the alarm
Alarm Three Direction	Hi going	Can be set to either low going or high going
Alarm Three Strobe Enable	On	Activates the strobe on alarm
Alarm Three Sounder Enable	On	Activates the sounder on alarm
Alarm Three Evacuation Enabled	Off	Activates the strobe and sounder of connected sensors on alarm
Alarm Three Latching Enable	Off	Requires the user to mute and acknowledge the alarm before the alarm will clear
Alarm Four Enabled	TRUE	Enable alarm
Alarm Four Set-point	10ppm	Threshold for the alarm
Alarm Four Direction	Hi going	Can be set to either low going or high going
Alarm Four Strobe Enable	On	Activates the strobe on alarm
Alarm Four Sounder Enable	On	Activates the sounder on alarm
Alarm Four Evacuation Enabled	Off	Activates the strobe and sounder of connected sensors on alarm
Alarm Four Latching Enable	Off	Requires the user to mute and acknowledge the alarm before the alarm will clear

20 Appendix I – Data Output Module MODBUS detail

The tables below show port and register configurations for interfacing to the DOM via Modbus.

20.1 MODBUS communications protocol

The table below lists the port settings and communications protocol required to interface to the DOM.

Parameter	Setting
Baud rate	19200
Data length	8 bits
Parity	Even
Stop bits	One
Protocol	Modbus RTU
Transfer	Half-duplex
Hardware protocol	RS485

20.2 MODBUS register map

The following table shows which Modbus registers hold additional information about the operation of the DOM and Ax60+ system. **Data is sent in big-endian format on the wire.**

Important restriction: the DOM only supports the requesting of one item at-a-time. For example, to request the contents of Read Input register 1 (Sensor Unit 1's gas reading) the request message will be for only two registers (1 & 2). If a request is made for multiple items, then exception code "Illegal Function" will be returned.

The table below lists the Read Input Status.

Function	Register	Type	Length	Comment
Read Input Status (02)	10001	Bit	1	Sensor Unit 1 fault condition
Read Input Status (02)	10002	Bit	1	Sensor Unit 2 fault condition
Read Input Status (02)	10003	Bit	1	Sensor Unit 3 fault condition
Read Input Status (02)	10004	Bit	1	Sensor Unit 4 fault condition
Read Input Status (02)	10005	Bit	1	Sensor Unit 1 alarm level 1 active
Read Input Status (02)	10006	Bit	1	Sensor Unit 2 alarm level 1 active
Read Input Status (02)	10007	Bit	1	Sensor Unit 3 alarm level 1 active
Read Input Status (02)	10008	Bit	1	Sensor Unit 4 alarm level 1 active
Read Input Status (02)	10009	Bit	1	Sensor Unit 1 alarm level 2 active
Read Input Status (02)	10010	Bit	1	Sensor Unit 2 alarm level 2 active
Read Input Status (02)	10011	Bit	1	Sensor Unit 3 alarm level 2 active
Read Input Status (02)	10012	Bit	1	Sensor Unit 4 alarm level 2 active
Read Input Status (02)	10013	Bit	1	Sensor Unit 1 alarm level 3 active
Read Input Status (02)	10014	Bit	1	Sensor Unit 2 alarm level 3 active
Read Input Status (02)	10015	Bit	1	Sensor Unit 3 alarm level 3 active
Read Input Status (02)	10016	Bit	1	Sensor Unit 4 alarm level 3 active
Read Input Status (02)	10017	Bit	1	Sensor Unit 1 alarm level 4 active
Read Input Status (02)	10018	Bit	1	Sensor Unit 2 alarm level 4 active
Read Input Status (02)	10019	Bit	1	Sensor Unit 3 alarm level 4 active
Read Input Status (02)	10020	Bit	1	Sensor Unit 4 alarm level 4 active
Read Input Status (02)	10021	Bit	1	DOM fault condition

The table below lists the Read Input Registers.

Function	Register	Type	Length	Comment
Read Input Register (04)	30001	Float	2	Sensor Unit 1 live reading
Read Input Register (04)	30003	Float	2	Sensor Unit 2 live reading
Read Input Register (04)	30005	Float	2	Sensor Unit 3 live reading
Read Input Register (04)	30007	Float	2	Sensor Unit 4 live reading
Read Input Register (04)	30009	UInt16	1	Sensor Unit 1 measurement display units
Read Input Register (04)	30010	UInt16	1	Sensor Unit 2 measurement display units
Read Input Register (04)	30011	UInt16	1	Sensor Unit 3 measurement display units
Read Input Register (04)	30012	UInt16	1	Sensor Unit 4 measurement display units
Read Input Register (04)	30013	String8	4	Sensor Unit 1 short description
Read Input Register (04)	30017	String8	4	Sensor Unit 2 short description
Read Input Register (04)	30021	String8	4	Sensor Unit 3 short description
Read Input Register (04)	30025	String8	4	Sensor Unit 4 short description
Read Input Register (04)	30029	UInt16	4	DOM status flags (see below)
Read Input Register (04)	30030	UInt16	4	Modbus address encoder raw output – 0 to 15 (for final test)
Read Input Register (04)	30031	UInt16	4	Ax60 message received. 0 indicates no message received. >=1 message(s) received (for final test)

The table below lists the DOM status flags.

Register value (HEX)	DOM status
0 (00)	No fault
1 (01)	DOM firmware corrupt
2, 4 or 6 (02, 04 or 06)	No / corrupt Ax60+ comms
8 (08)	No Ax60 configuration
16 (10)	Corrupt Modbus comms
32 (20)	DAC convertor failed
64 (40)	Corrupt DOM configuration
128 (80)	Corrupt DAC configuration

20.3 Changing DOM Node Addresses

The rotary encoder on the PCB can be used to change the node address of the data output modules if required when using the MODBUS output.

The factory setting of the node address is 1 (position 0).

For instance, if there are multiple systems in the building and all of the data output modules are connected to the building management system, then each of the data output module will require their node address changing so the building management system can communicate correctly with them via MODBUS.

Encoder position	Node address
0	1
1	2
2	3
3	4
4	5
5	6
6	7
7	8
8	9
9	10
A	30
B	45
C	87
D	100
E	151
F	246



MODBUS RTU CONNECTIONS



MODBUS connections to a building management system can be made via a RS485 link to the COM, A & B.

NOTE: J3 IS USED TO LINK IN THE BUS TERMINATION RESISTOR. THIS LINK IS TO BE FITTED IF THIS MODULE IS THE END NODE ON THE RS485 BUS.

21 Appendix J - Sensor characteristics and helium effect

The carbon monoxide sensor is a capillary type sensor. Capillary sensors are affected by helium (He). When He is present in large amounts, it causes the cell to read higher than expected. This is because He molecules are very small, allowing them to pass through the capillary quickly. The fast passage also permits carbon monoxide (CO) molecules, which are significantly larger, to diffuse more rapidly. Consequently, when He levels are high, more CO enters the sensor, this results in an output that exceeds the actual amount.

He causes capillary CO sensors to read incorrectly. So, the Ax60+ CO is modified to work properly with He. So, the Ax60+ CO must have precise calibration when used with a high-concentration of He.

He in the sample gas makes the CO cell more sensitive. When He is at its max (usually 99% for saturation-diving), the sensitivity increases about 1.3 times.

So, in 99% He, the cell's sensitivity is higher. This elevates the measurement signal to:

$$\begin{aligned} 5.0\text{ppm} / 1.3 &= 3.85\text{ppm CO} \\ &\approx 3.9\text{ppm CO} \end{aligned}$$

In a gas with 99% He, if the real CO concentration is 3.9ppm, the instrument displays 5.0ppm.

In saturation-diving, the oxygen (O₂) and He ratio varies. It typically ranges from 21% O₂/79% He to 1% O₂/99% He. The He level changes the CO cell sensitivity, so the user must properly calibrate the instrument. When they use a typical O₂/He mix, it causes an increase in sensitivity. The increase ranges from 1.0 to 1.3 times, therefore, it is mandatory for users to calibrate with 21% O₂ in He gas.

If the instrument is calibrated as specified, the anticipated typical performance is outlined below:

He in gas mix (%)	Alarm 1			Alarm 2		
	Set point	Actual CO (ppm)	Displayed CO (ppm)	Set point	Actual CO (ppm)	Displayed CO (ppm)
79	3	3.0	3.0	5	5.0	5.0
99	3	2.3	3.0	5	3.9	5.0

The table illustrates that as the percentage of helium (% of He) increases, there are cases where, even though the instrument indicates that the Alarm level is reached, the actual CO level present is lower. This arrangement ensures that any inaccuracies are 'fail-safe'.

The chart below shows the typical system performance with the influence of He. It shows how the actual CO level needed to activate the 5.0ppm alarm threshold changes as the He percentage changes.

The dark blue plot shows the typical performance with 0% He (Air diving). As the He percentage increases, the CO amount needed to trigger the 5.0ppm alarm decreases.

At 79% He, 2.42ppm CO is needed to trigger the alarm. At 99% He, 2.14ppm CO is needed to trigger it.

The pink plot shows the typical performance with 79% He. This is recommended for diving. In diving, He is usually 79% to 99%.

As the percentage increases, the CO amount needed to trigger the 5.0ppm alarm decreases.

At 99% He, 3.94ppm CO is needed to trigger it. This gives a 1.06ppm reading error. This configuration ensures fail-safe operation, addressing any potential inaccuracies.

The yellow plot shows the typical system performance when calibrated with calibration gas containing 99% He.

In saturation diving applications, He concentration typically ranges between 79% and 99%. As the He concentration decreases, the required CO level to trigger the 5.0ppm alarm increases.

At the 79% He level, about 6.35ppm of CO is necessary to activate the alarm.

This situation could be hazardous because the instrument may indicate less CO than is actually present. Hence, in saturation diving applications, it is crucial to calibrate the instrument with 79% He-balanced calibration gases, as outlined in the calibration procedure section.

