



SDA

User Manual

Commercial in Confidence

UK Office
15 Ellerbeck Court,
Stokesley Business Park,
North Yorkshire, TS9 5PT, UK

US Office
15121 Graham Street #B106,
Huntington Beach, California,
92649

UK / Global
info@analoxgroup.com
+44 (0)1642 711 400

US Office
ussales@analox.biz
(714) 891 4478
Toll Free: (877) 723 3247

List of Contents

1	Safety warnings	6
1.1	Electrochemical Sensors (O ₂ /CO) – Caustic Electrolyte	6
1.2	Pressurised gas	7
1.3	Helium Ingress	7
1.4	ESD and Electric Shock	7
2	Introduction	8
3	Overview	9
3.1	Packing Overview	9
3.2	Networking Capability	12
3.3	System Overviews	15
3.4	Accessories	31
3.5	Operation in the Bridge Zone	32
3.6	Monitor Controls Overview	33
4	Installation	34
4.1	Mounting	34
4.2	Monitor and Sensor Wiring	38
4.3	Output Module Wiring	44
4.4	Brackets	46
4.5	Pipe work	50
5	Operation	52
5.1	Start-up	52
5.2	Display	53
5.3	Sensor readings	55
5.4	Alarms	57
5.5	Adjusting the backlight	71
5.6	Viewing device information	71
5.7	Data-logging	72
5.8	Changing network parameters	73
5.9	Serial data output	73
5.10	Output module	75
5.11	Power modes	77
5.12	Cell replacement reminder	77
6	Configuration	79
6.1	Software installation	79
6.2	Making a connection	85
6.3	Changing options	87
6.4	Downloading data logs	90
6.5	Setting the time	92
7	Troubleshooting	93
7.1	Fault conditions	93
7.2	Fault logging	93
7.3	Problems and actions	94
7.4	Unhandled exceptions	94
8	Maintenance	95
8.1	Oxygen cell replacement	95
8.2	Carbon monoxide cell replacement	97

SDA

User Manual

Int. Approved

8.3	Helium cell replacement	101
8.4	Reconfiguring a unit	102
9	Spares and accessories.....	103
9.1	Spares	103
9.2	Accessories	103
9.3	Recommended calibration gases	104
9.4	Servicing.....	105
10	Specifications	106
10.1	SDA monitor	106
10.2	MEC oxygen sensor	107
10.3	Carbon dioxide sensor	108
10.4	MEC carbon monoxide sensor (For SDA CO)	109
10.5	TEC carbon monoxide sensor (For SDA CO+)	110
10.6	Temperature & humidity probe	111
10.7	Pressure sensor & 4-20mA MEC.....	111
10.8	Pressure sensor & APT RS485 module	112
10.9	MEC helium sensor	113
10.10	SDA Output Module	113
10.11	IP rating and general care.....	114
11	Warranty information	115
12	Fault reporting To Analox.....	116
13	UK Declaration of Conformity	117
14	Declaration of Conformity	118
15	Disposal	119
15.1	WEEE statement	119

Warnings, Cautions and Notes

Warnings and Cautions are used in this manual to highlight potential hazards and safety risks. Notes are used to provide supplementary information that is not hazard related.



WARNING: THIS INDICATES A POTENTIALLY HAZARDOUS SITUATION THAT, IF NOT AVOIDED, COULD RESULT IN DEATH OR SERIOUS INJURY.



CAUTION: THIS INDICATES A POTENTIALLY HAZARDOUS SITUATION THAT, IF NOT AVOIDED, COULD RESULT IN EQUIPMENT DAMAGE OR LOSS OF DATA.



NOTE: THIS INDICATES INFORMATION THAT IS CONSIDERED IMPORTANT BUT IS NOT HAZARD RELATED.

1 Safety warnings

1.1 Electrochemical Sensors (O₂/CO) – Caustic Electrolyte

Electrochemical sensors contain caustic compounds. Under normal conditions the sensor will be safely sealed. To prevent leakage, the unit must not be exposed to temperatures outside the specified range, or be exposed to organic vapours, which may cause physical damage to the body of the sensor. The unit must not be stored in areas containing organic solvents or in flammable liquid stores.

When the life of the sensor has expired, or it is leaking or otherwise damaged it must be disposed of safely in accordance with local regulations.

The carbon monoxide cell contains an acidic electrolyte (sulphuric acid) whilst the oxygen cell contains alkaline electrolyte (potassium hydroxide). In the event of an accident, use the following first aid procedures:

Body Part	Effect	First Aid Procedures
Skin	Contact could result in a chemical burn. Persons with pre-existing skin disorders may be more susceptible to the effects of the substance.	Immediately flush the skin thoroughly with water for at least 15 minutes. Remove contaminated clothing and wash before re-use. Obtain medical advice if continued irritation.
Ingestion	Corrosive. May cause sore throat, abdominal pain, nausea, and severe burns of the mouth, throat, and stomach, and may be fatal.	If swallowed DO NOT INDUCE VOMITING. Wash out mouth thoroughly with water and give plenty of water to drink. Obtain medical advice immediately
Eye	Persons with pre-existing eye problems may be more susceptible to the effects of the substance. Corrosive. May cause redness, pain, blurred vision, and eye burns. Contact can result in the permanent loss of sight.	Irrigate thoroughly with water for at least 15 minutes. Obtain medical advice immediately.
Inhalation	Persons with pre-existing impaired respiratory function may be more susceptible to the effects of the substance. Inhalation is not an expected hazard unless heated to high temperatures. Mist or vapour inhalation can cause irritation to the nose, throat, and upper respiratory tract.	Remove to fresh air. Rest and keep warm. Obtain medical advice if applicable.

1.2 Pressurised gas

- 1) Do not exceed the specified maximum pressures. Failure to do so may result in damage to the equipment and to personnel.
- 2) Users of this equipment **MUST** be familiar with the handling of pressurised gas.
- 3) Take particular care when handling toxic or flammable gases. In such cases ensure that all exhausts are vented into well ventilated areas.
- 4) For systems with exhaust outlets, do not block the exhaust outlet.

1.3 Helium Ingress

Care must be taken when choosing the location for the SDA sensor modules that include atmospheric pressure compensation. These include the MEC O₂ % (MECO2ABB) and SDA CO₂ modules. Helium can diffuse into the pressure sensing components in the sensor housing and affect the overall sensor accuracy.

To avoid helium ingress issue with the sensor modules, they should be fitted into well-ventilated panels or racks where the content in the atmosphere is ideally less than 1% helium. Levels exceeding this will degrade sensor performance and levels greater than 5% will reduce sensor life expectancy. Note that this does not affect the MEC O₂ partial pressure sensor (MECO2ABAP) as this does not include automatic pressure compensation.

1.4 ESD and Electric Shock

To prevent damage to the SDA units they must not be operated with any casework removed to prevent the likelihood of damage to the electronic components and accidental electric shock. The rear USB and Ethernet connectors are connected to chassis earth (enclosure). The stud on the rear of the case provides the main connection to protective earth which must be connected to maintain EMC performance.

2 Introduction

The SDA range is composed of a family of atmospheric analysis systems which are suitable for applications where continuous monitoring of atmospheres is required. Each type of system in the range will provide independent measurement and display of atmospheric variables with clear audible and visual alarms to warn when potentially dangerous levels are reached.

The SDA range is designed to be highly modular and flexible so that it can be easily integrated into custom atmospheric monitoring solutions.

The core of each analyser is a compact monitor unit which provides the display and user interface for the system. A full colour display gives clear reading and status information and is suitable for a wide range of lighting and mounting positions. The controls present quick and simple access to the most common system functions such as calibration and alarm adjustment, with more detailed setup and diagnostic information accessed through an easy-to-use menu system.

The communication ports on the rear of the monitor provide connections to a range of Analox gas and environmental sensors and peripherals. These provide the flexibility to mount sensors and peripherals alongside the monitor or up to hundreds of metres away without affecting performance.

The SDA range is compliant with the type approval specifications from the major classification societies in the marine industry for both the general power distribution and bridge zones (refer to section 3.5 for more details).

3 Overview

3.1 Packing Overview

Oxygen system (Inc. Dual Display O₂)

- 1) Oxygen monitor (rack or panel mount)
- 2) MEC oxygen sensor
- 3) Push in flow adaptor
- 4) 2-way Phoenix connector (DC power)
- 5) 5-way Phoenix connector (sensor communications & power)
- 6) 5-way Phoenix connector (output module communications & power)
- 7) USB lead
- 8) User manual
- 9) Test certificate

Carbon dioxide system (separates)

- 1) Carbon dioxide monitor (rack or panel mount)
- 2) Carbon dioxide sensor module (rack or panel mount)
- 3) 2-way Phoenix connector (DC power)
- 4) 5-way Phoenix connector (sensor communications & power)
- 5) 5-way Phoenix connector (output module communications & power)
- 6) USB lead
- 7) User manual
- 8) Test certificate

Carbon dioxide system (combined panel mount)

- 1) Combined carbon dioxide monitor and sensor module
- 2) 2-way Phoenix connector (DC power)
- 3) 5-way Phoenix connector (sensor communications & power)
- 4) 5-way Phoenix connector (output module communications & power)
- 5) USB lead
- 6) User manual
- 7) Test certificate

Carbon monoxide system (Standard SDA CO & SDA CO+)

- 1) Carbon monoxide monitor (rack or panel mount)
- 2) MEC carbon monoxide sensor (For standard SDA CO)
or TEC carbon monoxide sensor (For SDA CO+)
- 3) Push in flow adaptor
- 4) 2-way Phoenix connector (DC power)
- 5) 5-way Phoenix connector (sensor communications & power)
- 6) 5-way Phoenix connector (output module communications & power)
- 7) USB lead
- 8) User manual
- 9) Test certificate

Temperature & Humidity system

- 1) Temperature & Humidity monitor (rack or panel mount)
- 2) Temperature & Humidity probe (Chamber or In-line variant)
- 3) 2-way Phoenix connector (DC power)
- 4) 5-way Phoenix connector (sensor communications & power)
- 5) 5-way Phoenix connector (output module communications & power)
- 6) USB lead
- 7) User manual
- 8) Test certificate

Helium system

- 1) Helium monitor (rack or panel mount)
- 2) MEC helium sensor
- 3) Push in flow adaptor
- 4) 2-way Phoenix connector (DC power)
- 5) 5-way Phoenix connector (sensor communications & power)
- 6) 5-way Phoenix connector (output module communications & power)
- 7) USB lead
- 8) User manual
- 9) Test certificate

Depth system

- 1) Depth monitor (rack or panel mount)
- 2) MEC 4-20mA module
- 3) Pressure sensor (If specified at time of order, own pressure sensor can be used)
- 4) Pressure sensor 4-20mA cable
- 5) 2-way Phoenix connector (DC power)
- 6) 5-way Phoenix connector (sensor communications & power)
- 7) 5-way Phoenix connector (output module communications & power)
- 8) USB lead
- 9) User manual
- 10) Test certificate

Depth system (With RoC)

- 1) Depth monitor (rack or panel mount)
- 2) APT RS485 module
- 3) Pressure sensor (If specified at time of order, own pressure sensor can be used)
- 4) 2-way Phoenix connector (DC power)
- 5) 5-way Phoenix connector (sensor communications & power)
- 6) 5-way Phoenix connector (output module communications & power)
- 7) USB lead
- 8) User manual
- 9) Test certificate

Accessories (optional)

- 1) AC to DC +24VDC power supply unit (PSU)
- 2) MEC/APT sensor only mounting plate
- 3) Combined mounting plate (SDA output module and MEC oxygen sensor)
- 4) SDA output module (bracket / panel mount)
- 5) SDA flow meter plate (rack or panel mount)

3.2 Networking Capability



NOTE: THE SDA NETWORKING CAPABILITY IS ONLY RECOMMENDED FOR USE ON A LOCAL AREA NETWORK

The SDA system is capable of sharing data across Ethernet networks, either for communications between SDA Units for conversion and compensation, or with an active host, or passive listening device for external communications via the RJ45 socket that can be found at the rear of the SDA Unit. Multiple SDA Units can be linked together, or on a host network, via an Ethernet Switch Unit.

There are currently 2 core transport protocol methods used in the SDA:

1. User Datagram Protocol (UDP). Using this core protocol, each SDA, when configured, will transmit data, in a pre-determined format, which can then be utilized by other SDA's, or an external PC for the following purposes:
 - a. Intra-SDA sharing of data for cross-compensation purposes. For example, SDA Units can be configured to share pressure data across the network; sensor value readings in 'listening' SDA Units can be manipulated to show pressure-compensated values on the display.
 - b. External data access can be achieved where an external device, such as a monitoring PC, could be used to listen to individual SDA's on the network for monitoring or data-logging purposes. Each SDA can be configured to broadcast data on a range of base ports, configurable in the Networking Menu.
2. Transmission Control Protocol (TCP). Using this core protocol, external devices can send requests to SDA Units for data, using a pre-determined format. A host device, such as a PC, would send a request for data to one or more SDA Units on a network, on an individual request basis, to specific IP addresses. The SDA Units can be user-configured to specific IP addresses via the Networking Menu, so the user can specify which addresses to use, where required.

For UDP communications, SDA Units are allocated a base port address, with an offset which is determined by sensor type. There is an additional offset available to allow for multiple types of the same gas sensor on the same network. Any device wishing to 'listen' to data transmissions from the SDA Unit, must listen out on the specific Port Address for that SDA and Sensor.

The following tables can be used to verify that the correct UDP address is set in your SDA:

Base Port = 900

Sensor Type	Offset Value
None	0
Carbon Dioxide	+1
Oxygen	+2
Carbon Monoxide	+3
Dew point	+5
Hydrogen	+6
Helium	+7
Pressure (Depth)	+8
Temperature	+9
Humidity	+10
Nitric Oxide	+11
Nitrogen Dioxide	+12
Hydrogen Sulphide	+13
Sulphur Dioxide	+14
Ozone	+15

Same sensor-type offsets can be calculated using the following table:

Base Port = 900

Same Type Sensor Number	Offset Value
1	+0
2	+100
3	+200
4	+300
5	+400
6	+500
7	+600
8	+700
9	+800
10	+900
11	+1000
12	+1100
13	+1200
14	+1300
15	+1400
16	+1500

Example 1

When using a single Oxygen SDA Unit, and a single Pressure SDA Unit, the UDP Port Addresses should be configured as follows:

Oxygen = 900 (Base Port) + 2 (Oxygen Offset) = 902

Pressure = 900 (Base Port) + 8 (Pressure Offset) = 908

Example 2

When using 2 Oxygen SDA Units, and a single Pressure SDA Unit on the network, the UDP base port will need to be changed to avoid network conflicts:

Oxygen 1 = 900 (Base Port) + 2 (Oxygen Offset) = 902

Oxygen 2 = 1000 (Base Port) + 2 (Oxygen Offset) = 1002

Pressure = 900 (Base Port) + 8 (Pressure Offset) = 908



NOTE:

SDA UNITS THAT ARE LISTENING TO OTHER SENSOR TYPES ON THE NETWORK, WILL AUTOMATICALLY BE CONFIGURED TO LOOK ON THE APPROPRIATE PORT FOR THE SENSOR TYPE AND THE CONFIGURED BASE PORT.

FOR EXAMPLE, IF THERE ARE MULTIPLE PRESSURE SDA UNITS BROADCASTING DATA ON THE NETWORK, ANY SDA WISHING TO USE PRESSURE DATA FROM THE UDP BROADCASTS, CAN ONLY SUBSCRIBE TO THE PRESSURE SENSOR ON ITS OWN BASE PORT.

FOR TCP COMMUNICATIONS, THE HOST PC WOULD SEND DATA REQUESTS TO SDA UNITS ON AN INDIVIDUAL BASIS, AND THE SDA UNITS WILL RESPOND INDIVIDUALLY; THE IP ADDRESS AND SERVER PORT ARE CONFIGURABLE IN THE NETWORKING MENU.

THE UDP AND TCP DATAGRAMS FOR SDA COMMUNICATIONS ARE AVAILABLE ON THE ANALOX WEBSITE, AND ARE ALSO INCLUDED ON THE SDA SOFTWARE DISC.

3.3 System Overviews

3.3.1 SDA O₂

There are two types of oxygen monitoring system arrangement based on a SDA Monitor and MEC O₂ sensor, depending on which monitoring application is required. The MEC O₂ sensor is designed to operate in either atmospheric or hyperbaric environments, to depths of 350 msw.

The atmospheric version of the sensor is ranged to 100% O₂ and has inbuilt pressure compensation which will automatically adjust to changes in the ambient atmospheric pressure. This enables accurate measurement and adjustment when operating in atmospheres between 700 mbara and 1100 mbara. When fitted with a flow adaptor, as shown in the figure below, the 100% O₂ version of the sensor can monitor a sample line from a remote source or chamber (refer to section 4.5 for pipe work detail). When used without a flow adaptor the MEC O₂ sensor will measure oxygen in the surrounding ambient atmosphere diffusing across the sensor membrane.



CAUTION: ENSURE THAT WHEN USED WITH A FLOW ADAPTOR THAT SAMPLE PRESSURE IS REDUCED DOWN TO ALMOST ATMOSPHERIC PRESSURE BEFORE PASSING TO THE SENSOR. THIS WILL PREVENT POTENTIAL DAMAGE TO THE SENSOR AND AFFECTS THAT CAN CAUSE ELEVATED SENSOR READINGS. A FLOW RATE BETWEEN 0.2 AND 1.0 L/MIN IS ACCEPTABLE, 0.5 L/MIN IS RECOMMENDED.

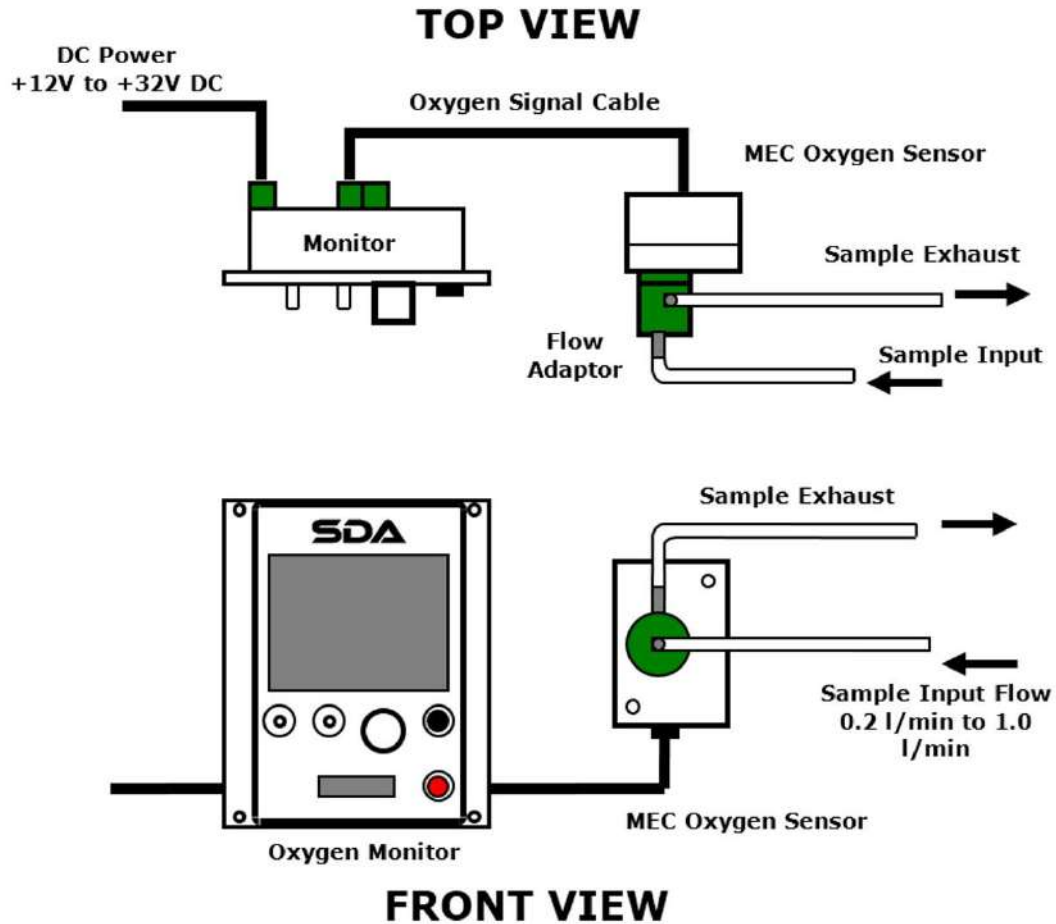

Figure 1 SDA oxygen system overview

The hyperbaric version of the O₂ sensor will measure partial pressures up to 3000 mbar O₂ and operate in pressures up to 36 bara. In this application a longer cable must be fitted to provide the connection to the monitor, which remains outside of the hyperbaric atmosphere (see figure below).

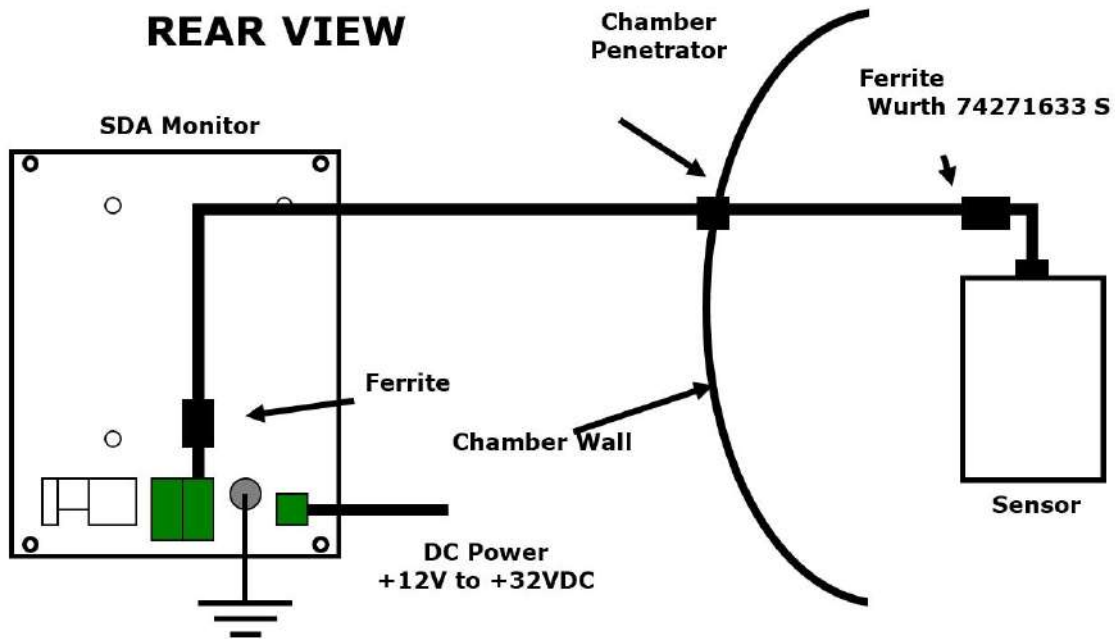

Figure 2 Sensor inside a saturation dive chamber



CAUTION: LONG SIGNAL AND POWER CABLES CAN INCREASE EMC EMISSIONS AND BE MORE SUSCEPTIBLE TO EMC INTERFERENCE. FOR SIGNAL CABLE LENGTHS GREATER THAN 1.5 METRES, SIGNAL FERRITES ARE RECOMMENDED TO BE FITTED (SEE ABOVE).

3.3.2 SDA Dual Display O₂

The dual display O₂ variant of the SDA is physically identical to the standard O₂ SDA but requires a pressure input to convert the mbar units from the O₂ sensor to a percent value and shows both mbar and percent values on the display screen as shown below.

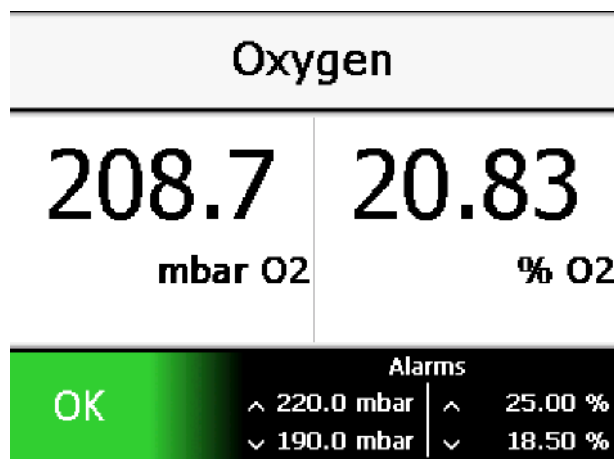

Figure 3 Dual Display O₂ screen

One option is that the sensor can be located outside of the chamber and use a pressure sensor located within the chamber to give the sensor the hyperbaric pressure reading from the chamber.



CAUTION: ENSURE THAT WHEN USED WITH A FLOW ADAPTOR THAT THE SAMPLE PRESSURE IS REDUCED DOWN TO ALMOST ATMOSPHERIC PRESSURE BEFORE PASSING TO THE SENSOR. THIS WILL PREVENT POTENTIAL DAMAGE TO THE SENSOR AND AFFECTS THAT CAN CAUSE ELEVATED SENSOR READINGS. A FLOW RATE BETWEEN 0.2 AND 1.0 L/MIN IS ACCEPTABLE, 0.5 L/MIN IS RECOMMENDED.

Another option would be to locate the O₂ sensor within the chamber, 2 options are available:

- A low-pressure variant (Up to 10bara) where the pressure reading is taken from the O₂ sensors on-board pressure sensor to give the hyperbaric pressure for conversion
- A high-pressure variant (Up to 40bara) where the pressure reading can be taken from a pressure sensor located within the chamber to give the sensor the hyperbaric pressure reading.



NOTE: CALIBRATION IS PERFORMED DIFFERENTLY TO A STANDARD O₂ SDA, CALIBRATION CAN BE PERFORMED AS PER SECTION 5.4.9

3.3.3 SDA CO₂

The SDA CO₂ is composed of an SDA Monitor and a CO₂ module with a 220mm signal cable. The module contains the carbon dioxide sensor and is designed to fit alongside the monitor in a rack or panel (depending on which type is supplied). Where longer distances are required between the CO₂ module and the monitor, the cable connection can be extended with the use of a terminal block with a cable of 2 twisted pairs with an outer shield.

The sample lines are compatible with 6mm OD, 4mm ID flexible tubing. The input sample passes through the flow meter first and can take a maximum input pressure of 6 bara.



CAUTION: THE FLOW MUST BE REGULATED ON THE FLOW METER TO BE GREATER THAN 0.2 L/MIN AND LESS THAN 1.0 L/MIN, A FLOW OF 0.5 L/MIN IS RECOMMENDED. WHEN BOTH SDA O₂ AND SDA CO₂ SYSTEMS ARE FITTED IN THE SAME RACK OR PANEL, THE EXHAUST LINE FROM THE CO₂ SYSTEM MAY BE CONNECTED TO INPUT OF THE O₂ FLOW ADAPTOR TO IF IT IS REQUIRED TO MONITOR THE SAME SAMPLE LINE.



NOTE: WHEN CALIBRATING THE CO₂ SENSOR, CARE SHOULD BE TAKEN WHEN SELECTING THE CALIBRATION GAS USED. THE BALANCE OR BACKGROUND GAS CAN HAVE AN EFFECT ON THE SENSOR READING, IF CALIBRATING WITH A NITROGEN BALANCE GAS AND THE SENSOR IS THEN SHOWN A HELIUM BALANCE GAS AFTER CALIBRATION, THE SENSOR WILL READ CONSIDERABLY LOWER. IF CALIBRATED WITH A HELIUM BALANCE GAS AND THE SENSOR IS THEN SHOWN A NITROGEN BALANCE GAS AFTER CALIBRATION, THE SENSOR WILL READ CONSIDERABLY HIGHER.

Select the calibration balance gas to match the intended background gas to be measured. See section 4.5.2 for fitting details.

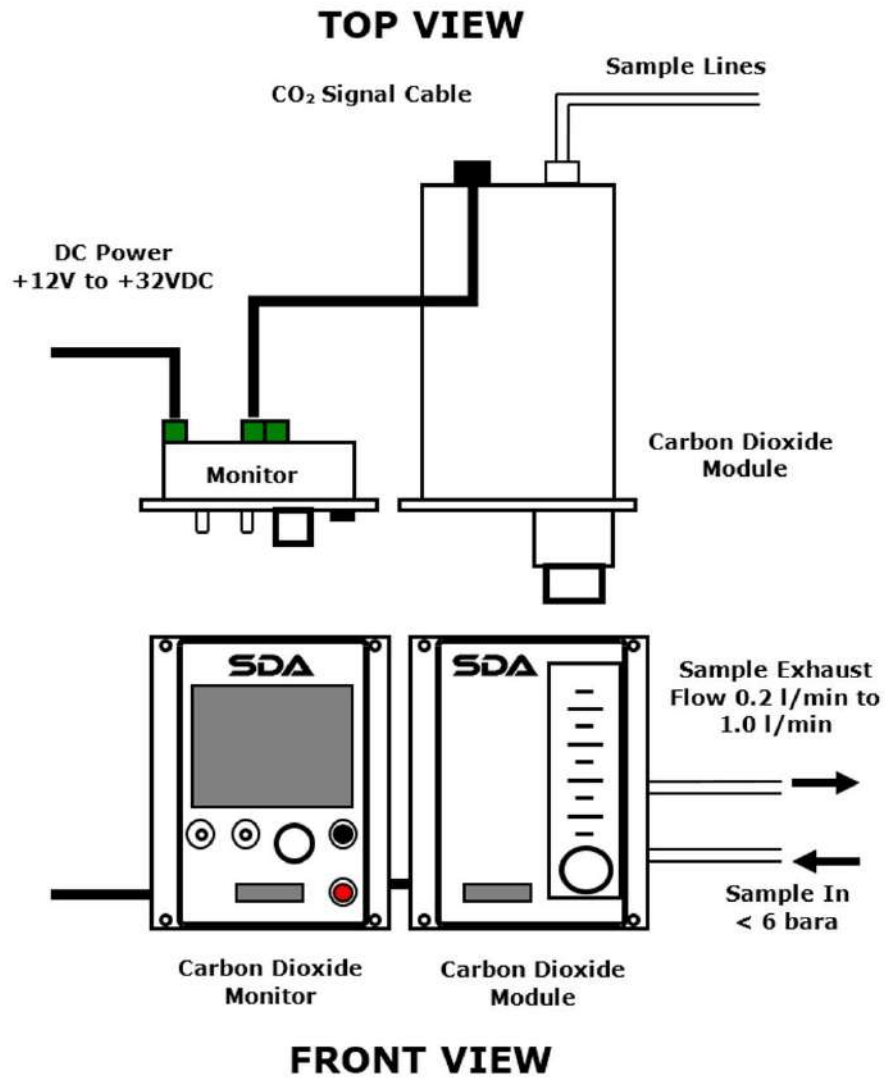

Figure 4 SDA carbon dioxide system overview

3.3.4 SDA CO & SDA CO+

The SDA CO is composed of an SDA Monitor and MEC CO sensor module with a 150mm signal cable. The SDA CO+ is composed of an SDA Monitor and TEC CO sensor module with a 200mm signal cable. The SDA CO+ meets the accuracy requirements to detect CO gas outlined in NORSOK U-100, Section 5.2.3.6.3, Table 4 and BS 8478, Section 4.7, Table 5

Both variants of sensors are ranged to 20ppm CO and have inbuilt temperature compensation, which will automatically adjust to changes in the ambient temperature. When fitted with a flow adaptor, as shown in the figure below, the 20ppm CO version of the sensor can monitor a sample line from a remote source or chamber (refer to section 4.5 for pipe work detail). When used without a flow adaptor the MEC or TEC CO sensors will measure carbon monoxide in the surrounding ambient atmosphere diffusing across the sensor membrane.



CAUTION: ENSURE THAT WHEN USED WITH A FLOW ADAPTOR THAT SAMPLE PRESSURE IS REDUCED DOWN TO ALMOST ATMOSPHERIC PRESSURE BEFORE PASSING TO THE SENSOR. THIS WILL PREVENT POTENTIAL DAMAGE TO THE SENSOR AND AFFECTS THAT CAN CAUSE ELEVATED SENSOR READINGS. A FLOW RATE BETWEEN 0.2 AND 1.0 L/MIN IS ACCEPTABLE, 0.5 L/MIN IS RECOMMENDED.



NOTE: WHEN CALIBRATING THE CO SENSOR, CARE SHOULD BE TAKEN WHEN SELECTING THE CALIBRATION GAS USED. THE BALANCE OR BACKGROUND GAS CAN HAVE AN EFFECT ON THE SENSOR READING AS EXPLAINED IN SECTION 3.3.4.1.

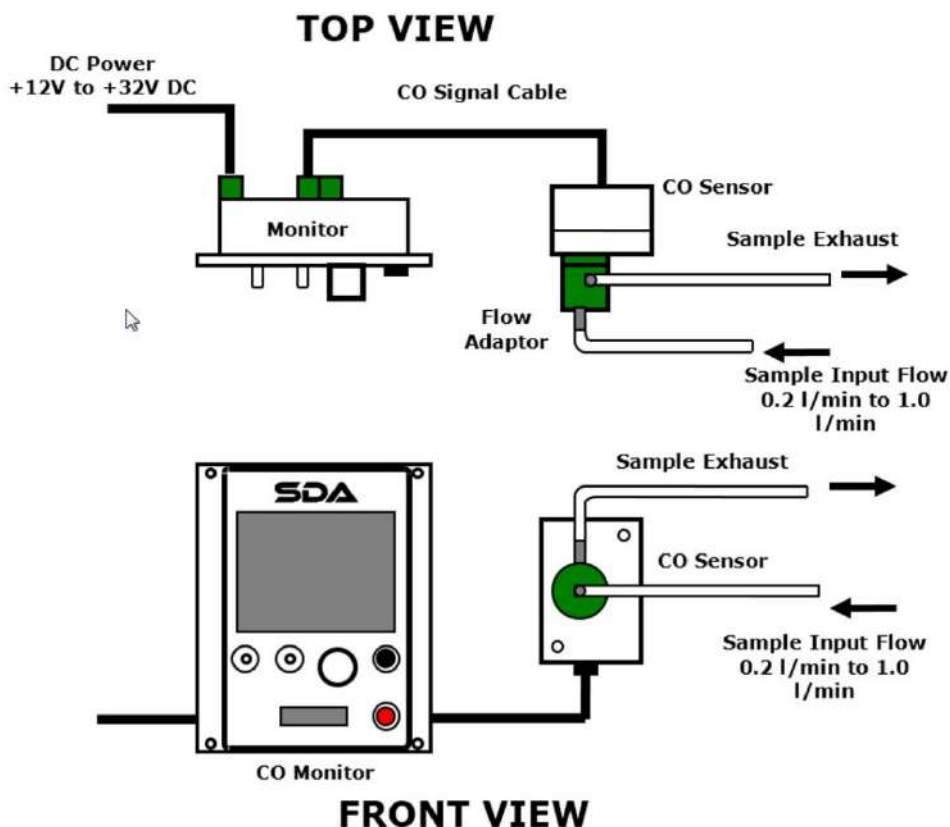

Figure 5 SDA carbon monoxide system overview

3.3.4.1 Sensor characteristics in the presence of helium



NOTE: WHEN CALIBRATING THE CO SENSOR, CARE SHOULD BE TAKEN WHEN SELECTING THE CALIBRATION GAS USED. THE BALANCE OR BACKGROUND GAS CAN HAVE AN EFFECT ON THE SENSOR READING AS EXPLAINED IN THE FOLLOWING TEXT.

Select the calibration balance gas to match the intended background gas to be measured.

The carbon monoxide sensor is a capillary type sensor. This type of sensor is affected by the presence of helium. When exposed to a gas containing significant amounts of helium the sensor will over-read.

The reason for this phenomenon, is down to the small size of the helium molecule compared to other molecules present (mostly nitrogen and oxygen molecules). The helium molecules diffuse more rapidly through the capillary into the sensor, allowing more capacity for the larger carbon monoxide (CO) molecules to enter the sensor. More CO molecules in the sensor results in a stronger electrochemical reaction and an artificially high reading.

The size of the over reading is dependent upon the amount of helium present. As a worst case, an instrument calibrated on an air balanced gas, will over-read by a factor of 2.3 if exposed to a helium balanced gas. This means that the instrument will read 4.6ppm when exposed to 2ppm CO gas.

The following graph approximately shows how the over-read factor varies with Helium concentration:

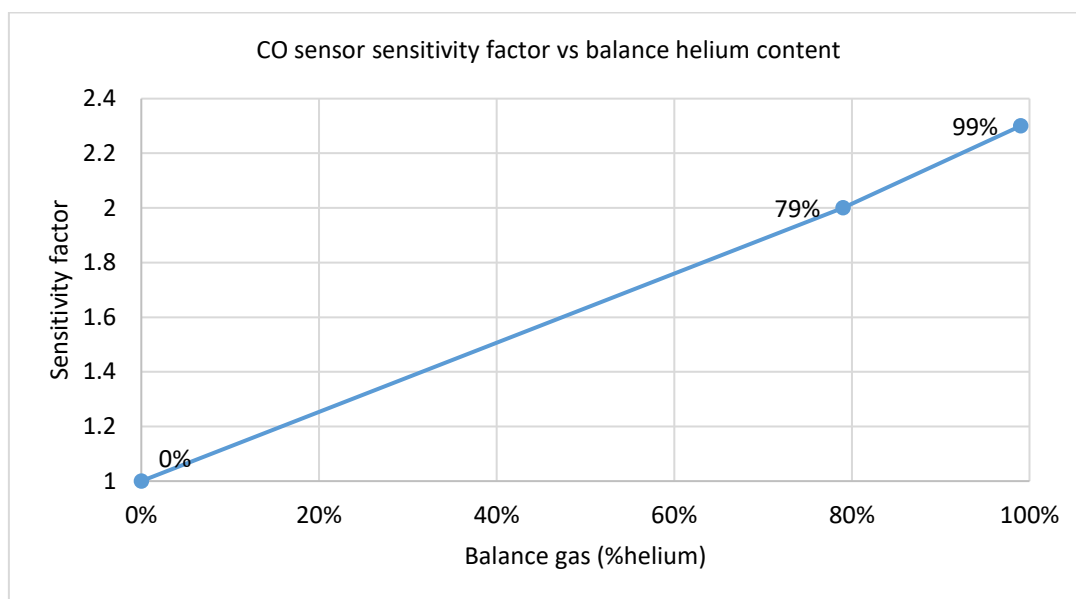

This over-reading can be removed by calibration. For the best accuracy of CO measurement, calibrate the instrument with gases that closely match the balance gas that will be measured in your application. I.e. if the measured gas contains 99% Helium and 1% O₂, a calibration gas containing 18ppm CO, 1% O₂ and helium balance will give the greatest accuracy of measurement. It should be noted that this correction only works while the measured balance gas remains the same as the calibration gas



WARNING: IN THE SAME WAY AS A SENSOR OVER-READS WHEN CALIBRATED IN AIR AND EXPOSED TO HELIUM. AN INSTRUMENT CALIBRATED IN HELIUM WILL UNDER-READ WHEN EXPOSED TO AIR. IN SOME APPLICATIONS IT IS NORMAL FOR THE BALANCE GAS TO CHANGE DURING OPERATION. CARE MUST BE TAKEN TO ENSURE THAT THE ALARMS WILL TRIGGER AT THE CORRECT LEVEL OF CO FOR ALL LEVELS OF BALANCE GAS EXPECTED. THIS IS TO ENSURE THE SAFETY OF THOSE BREATHING THE GASES. FOR EXAMPLE, IF THE INSTRUMENT IS CALIBRATED ON A HELIUM BALANCE GAS, A SIGNIFICANTLY HIGHER CONCENTRATION OF CO WILL BE REQUIRED TO TRIGGER THE ALARMS IF THE BALANCE GAS MEASURED IS AIR.

For this reason Analox recommend, that a gas that is air balanced (18ppm CO, air balance) is best, as this offers safe triggering of alarms regardless of the gas being measured. The alarms will trigger early when exposed to helium balanced gases, however this normally considered to be a safe situation.

3.3.5 SDA He

The SDA He is composed of an SDA Monitor and MEC He module with a 150mm signal cable. The sensor is ranged to 100% He. When fitted with a flow adaptor, as shown in the figure below, the sensor can monitor a sample line from a remote source or chamber (refer to section 4.5 for pipe work detail). When used without a flow adaptor the MEC He sensor will measure helium in the surrounding ambient atmosphere diffusing across the sensor membrane.



CAUTION: ENSURE THAT WHEN USED WITH A FLOW ADAPTOR THAT SAMPLE PRESSURE IS REDUCED DOWN TO ALMOST ATMOSPHERIC PRESSURE BEFORE PASSING TO THE SENSOR. THIS WILL PREVENT POTENTIAL DAMAGE TO THE SENSOR AND AFFECTS THAT CAN CAUSE ELEVATED SENSOR READINGS. A FLOW RATE BETWEEN 0.2 AND 1.0 L/MIN IS ACCEPTABLE, 0.5 L/MIN IS RECOMMENDED.



NOTE: ZERO & SPAN CALIBRATIONS MUST CONTAIN 0% OXYGEN, IF O₂ IS PRESENT IN THE GAS USED FOR CALIBRATION IT WILL GIVE A NEGATIVE OFFSET. E.G. (100% O₂ = -4%He, 20.9% O₂/N₂ = -1% He)



NOTE: PLEASE NOTE THE ACCURACIES IN SECTION 10.9 DEPENDING ON WHETHER IT IS BEING USED AS A STAND-ALONE SENSOR OR NETWORKED TO AND COMPENSATED BY AN O₂ SDA

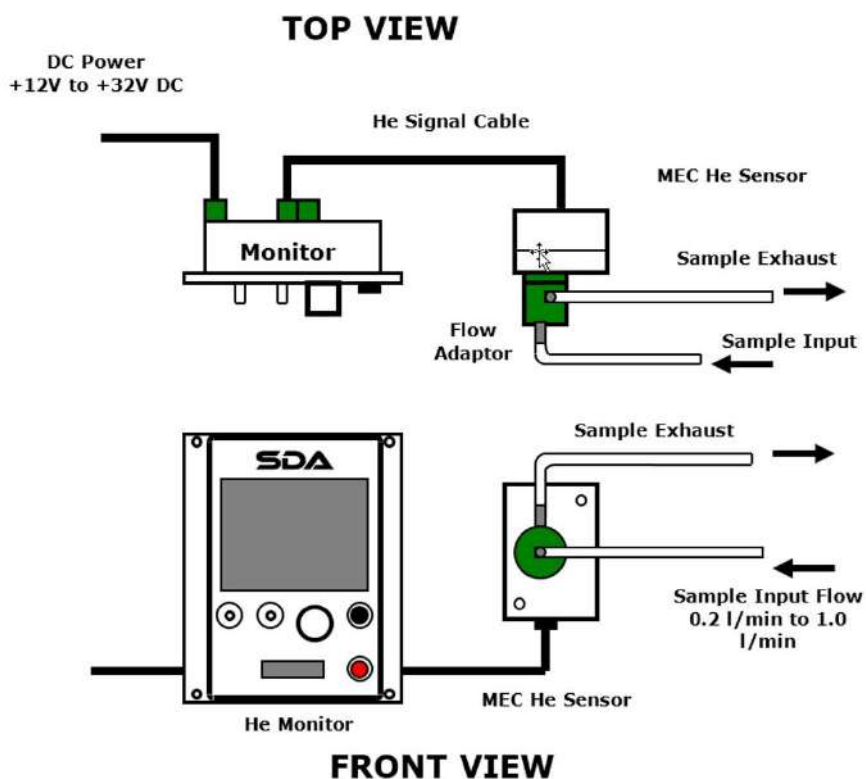

Figure 6 SDA helium system overview

3.3.6 SDA Temperature & Humidity

The SDA T&H is composed of an SDA Monitor and a Temperature & Humidity Probe, which can be used either in a chamber or in-line. The probe is ranged from 0 to 100 °C (32 to 212 °F) and 0 to 100%RH. When fitted in a chamber, the probe will measure temperature and relative humidity in the surrounding ambient atmosphere (Figure 7 SDA Temperature & Humidity **chamber system** overview

up to pressures of 35bara. When fitted in-line, the probe will measure temperature and relative humidity in the piped air supply (**Figure 8**) up to a maximum pressure of 100bara. Connection can be made to the in-line probe using a G½ female fitting.

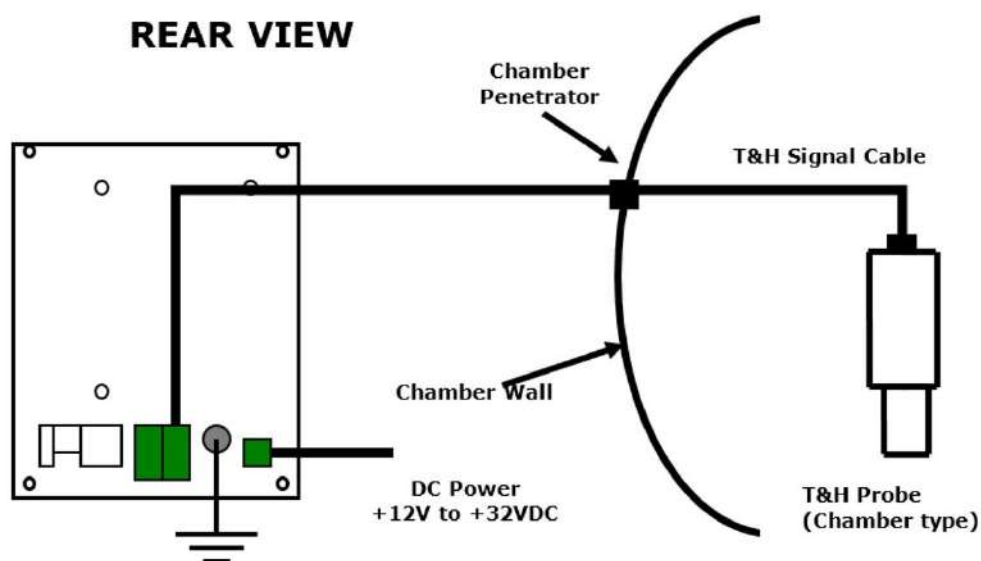

Figure 7 SDA Temperature & Humidity chamber system overview

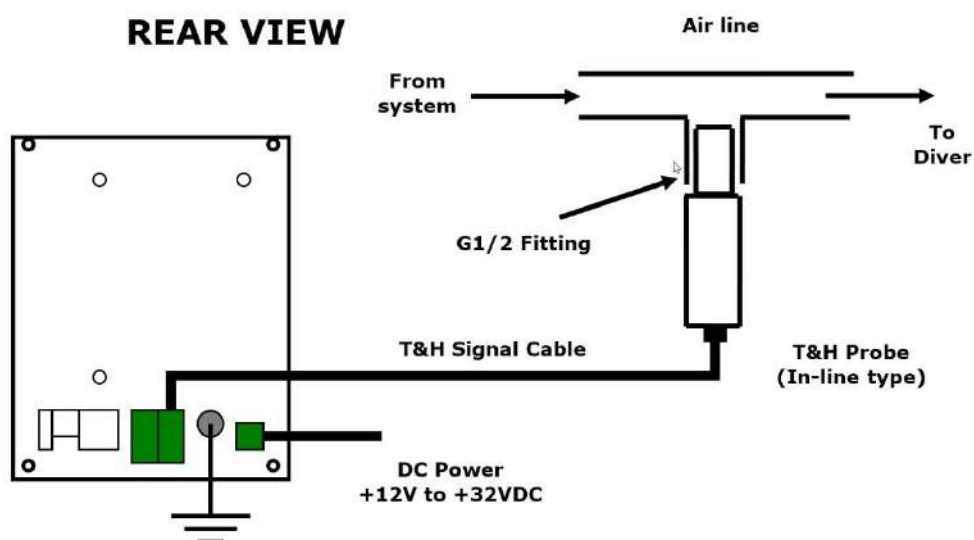

Figure 8 SDA Temperature & Humidity In-line system overview

3.3.7 SDA Depth

The SDA Depth is composed of an SDA Monitor and MEC 4-20mA module with a 150mm signal cable. The sensors can be ranged up to 100 bar (The correct range should be calibrated at time of installation according to the target sensor range).

When connected the sensor can monitor an analogue signal from a remote 4-20mA pressure sensor either inside or outside chamber. The mating connector cable is 2m in length as standard, this can be extended by the end user.

User calibration can be done by using the controls on the front of the monitor (See section 5.4.10)

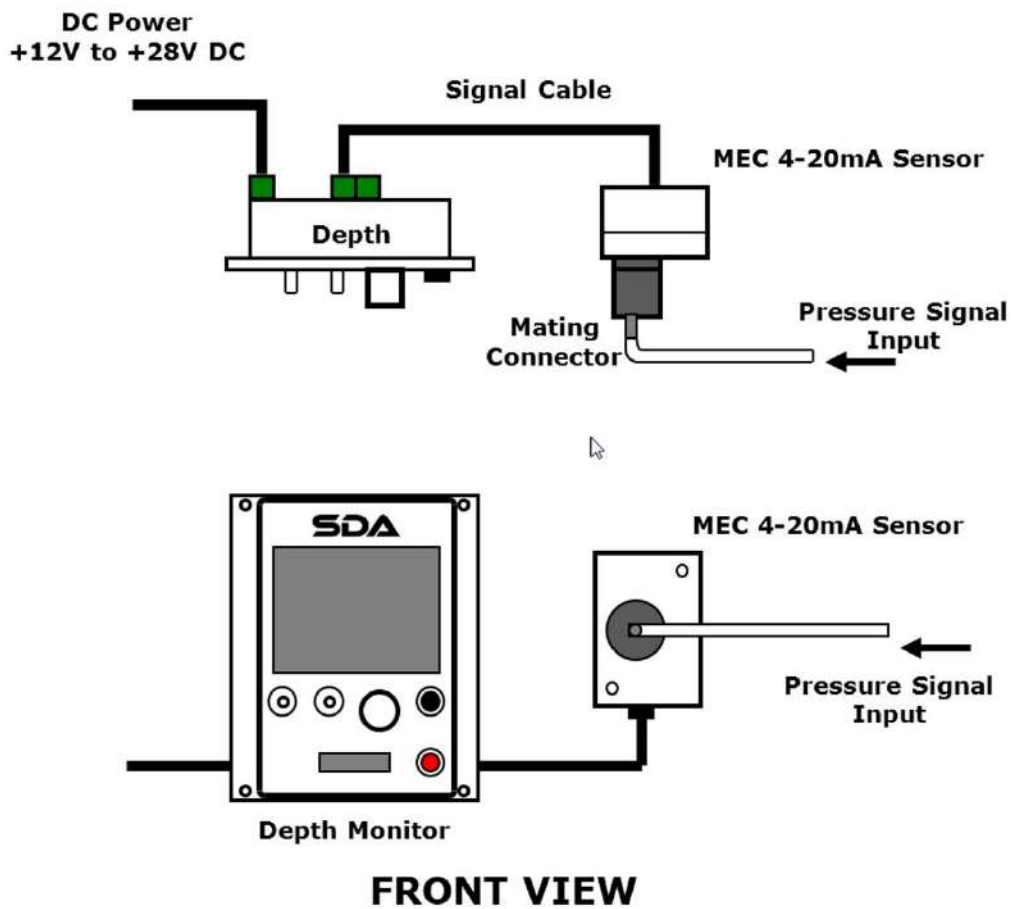

Figure 9 SDA depth system overview

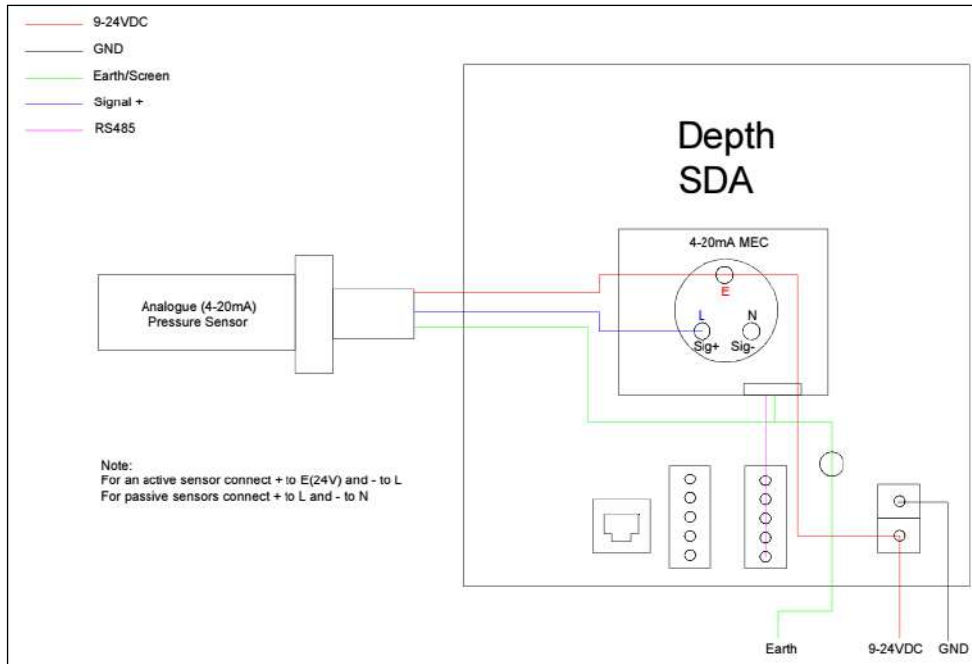

Figure 10 SDA depth sensor connection

3.3.8 SDA Depth with Rate of Change alarms (RoC)

The SDA Depth (RoC) is composed of an SDA Monitor and APT RS485 module with a 150mm signal cable and a 550mm RS485 sensor cable with flying leads. The sensors can be ranged up to 100 bar (The correct range should be calibrated at time of installation according to the target sensor range). When connected the sensor can monitor a digital signal from a remote RS485 pressure sensor either inside or outside chamber. The mating cable is 550m in length as standard, this can be extended by the end user using a junction box termination.

The difference between the standard SDA Depth and the SDA Depth (RoC) is how the alarms work when being in a state of compression or de-compression and that you can meet the accuracy requirements of DNV-OS-E402 (October 2010) using an SDA Depth with RoC.



NOTE:

USER CALIBRATION OF THE PRESSURE SENSOR REMAINS THE SAME ON BOTH THE STANDARD SDA DEPTH AND THE SDA DEPTH (ROC) BY USING THE CONTROLS ON THE FRONT OF THE MONITOR, BUT IF WANTING TO MEET ACCURACY REQUIREMENTS OF DNV-OS-E402 THE SENSOR SHOULD BE CALIBRATED USING A KNOWN CERTIFIED REFERENCE, HAVING A THIRD PARTY CALIBRATE THE SENSOR USING THEIR OWN CERTIFIED EQUIPMENT OR THE SENSOR MUST BE RETURNED FOR CALIBRATION BY A KNOWN CERTIFIED BODY.

The SDA Depth (ROC) alarm detail is detailed in section 5.4.3

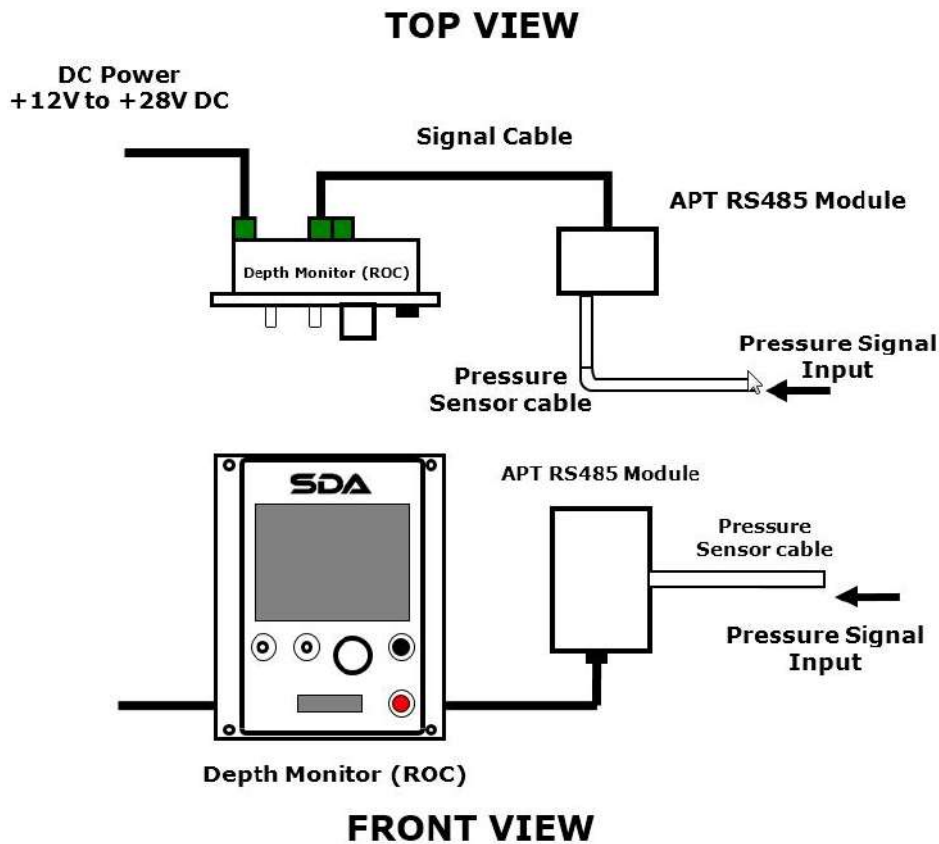

Figure 11 SDA depth (ROC) system overview

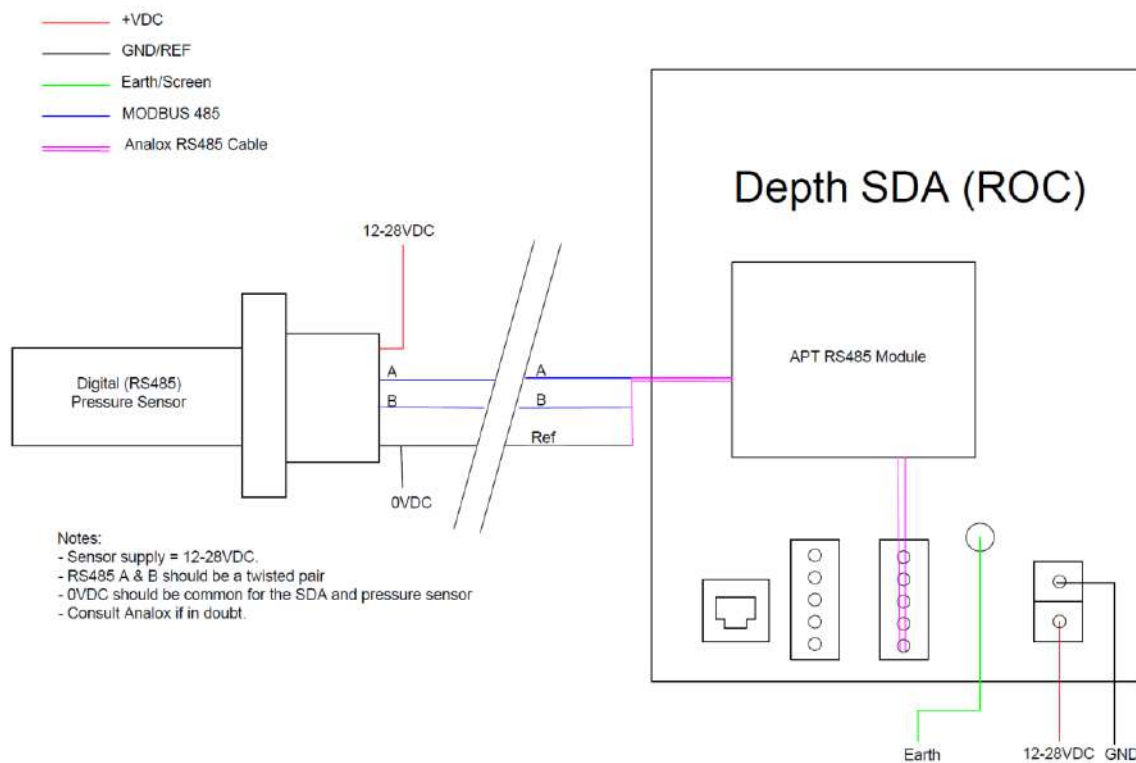

Figure 12 SDA depth (ROC) sensor connection

3.3.8.1 Electrical & pneumatic connection to the Keller Druck PR33X pressure transducer

The Keller Druck PR33X pressure transducer is provided with a Binder 423 cable connector for connection to the APT module.

The below diagrams show an example of the exploded view of the Binder connector and how to wire the Binder connector using the RS485A & RS485B wires from the APT, it also shows how to wire the external 12-28V dc source required to power the pressure transducer.

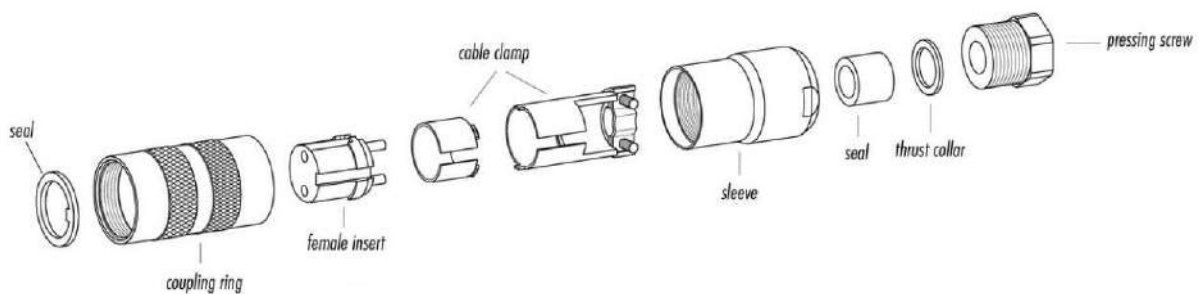

Figure 13 Exploded view of Binder 423 connector

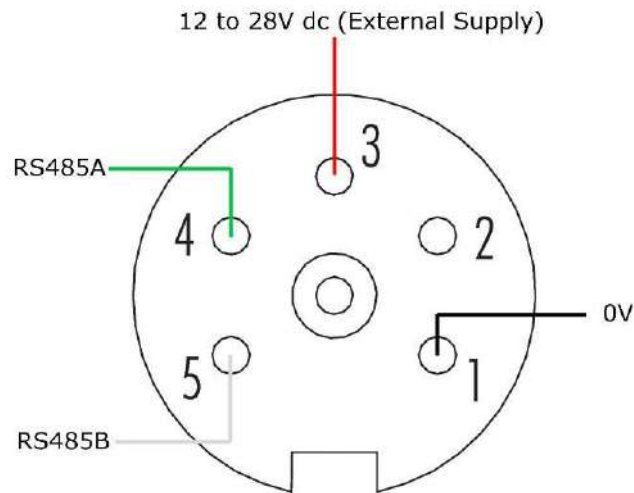

Figure 14 *Rear view (Solder terminals) of the female insert*

The Keller Druck PR33X pressure transducer can be connected directly to the APT using the APT RS485 lead fitted to the APT (Bootlace ferrules may require removing (Green & White wires), or it can be wired through a bulkhead.

Pneumatic connection (If required) to the Keller Druck PR33X pressure transducer should be made using a suitable G1/4" Female compression fitting and suitable tubing suitable for the required pressure.

3.4 Accessories

3.4.1 Mounting plate accessories

Two brackets may be used to mount the MEC sensor to SDA Monitor. If a power supply or SDA Output Module is required, the combined bracket can be fitted. Refer to section 4.4 for more detail.

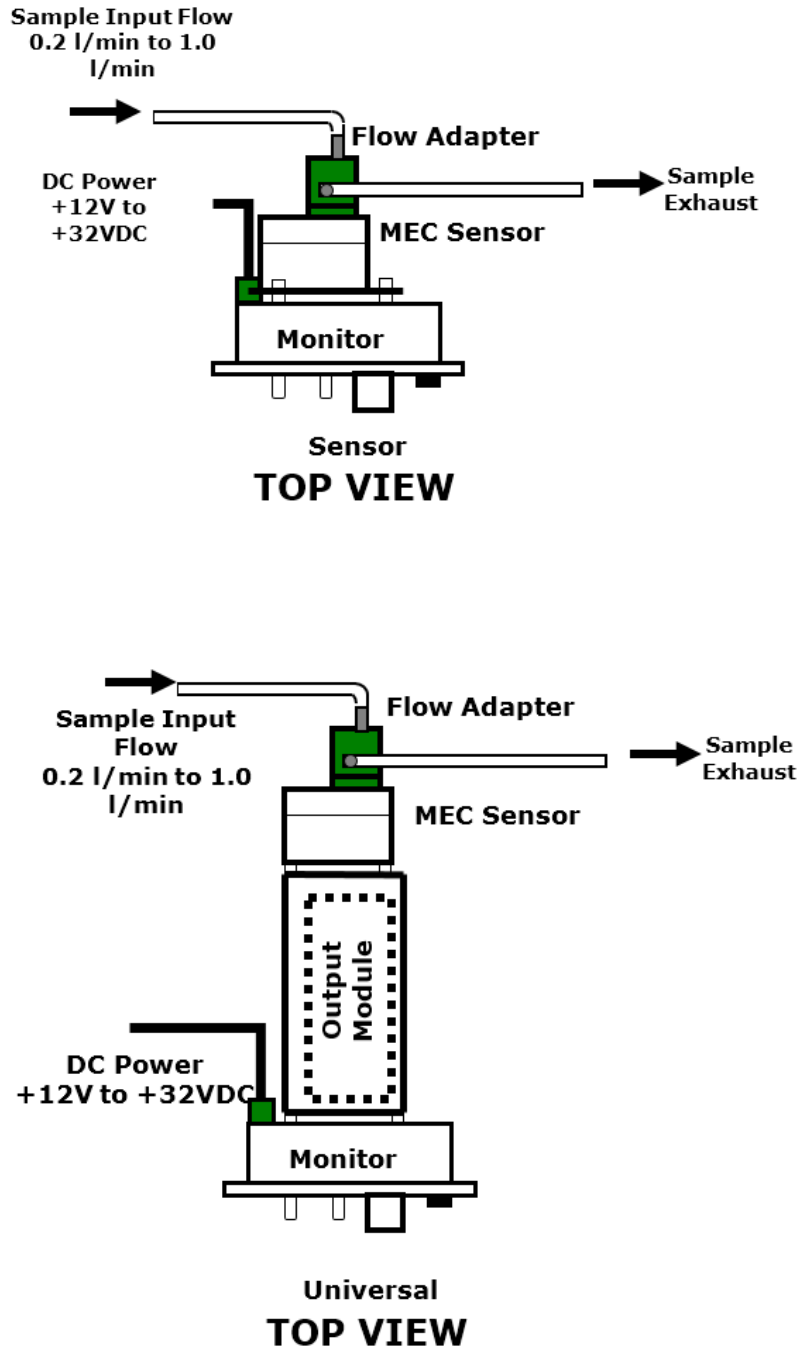

Figure 15 Mounting plates and accessories overview

3.5 Operation in the Bridge Zone

The SDA systems meets EMC requirements for the general power distribution zones defined in type approval specifications for Lloyd's Register, DNV and ABS classification societies. To fit into the bridge zone a filter must be fitted to comply with rules on radio interference, as shown below to the DC supply. Refer to section 4 for detailed system wiring.

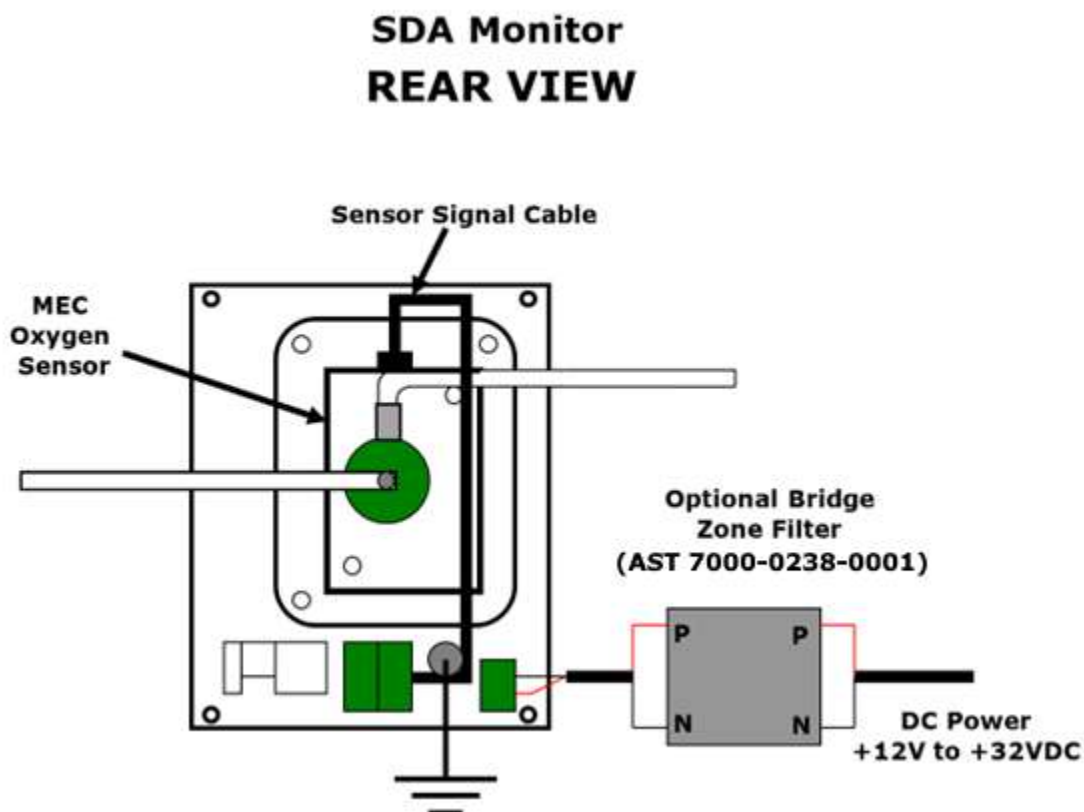

Figure 16 *Bridge distribution zone*



NOTE: THE PREVIOUS DESIGN OF THIS PRODUCT REQUIRES ANALOX PART NUMBER 2533-1005. THIS FILTER REQUIRES A PROTECTIVE EARTH CONNECTION.

3.6 Monitor Controls Overview

The below figure shows an overview of the controls located on the front panel of an SDA.



Figure 17 SDA front panel overview

- 1) Colour TFT LCD display
- 2) Adjustment knob
- 3) Calibration adjustment toggle switch
- 4) Set button
- 5) Alarm adjustment toggle switch
- 6) Mute button

4 Installation



NOTE: PLEASE OBSERVE THE SAFETY INFORMATION IN SECTION 1 BEFORE INSTALLATION.

4.1 Mounting

4.1.1 Rack Mounting

Rack versions are designed to be mounted onto standard 19" mounting rails. The systems are 3U high and 21hp wide so 4 modules will occupy the full width of the standard 84hp wide 19" rail.

4.1.2 Panel Mounting

Panel versions are suitable for direct mounting into instrument panels and they will fit the same apertures used by the older series of Analox 1000 and 5001 analysers. The cut-out aperture should measure as follows:

- Height - 112mm
- Width - 102mm

Mounting centres for panel mount variants should be as follows:

- Holes - 4 x 6mm
- Height - 122.5mm
- Width - 91.4mm
- Centred - On cut out

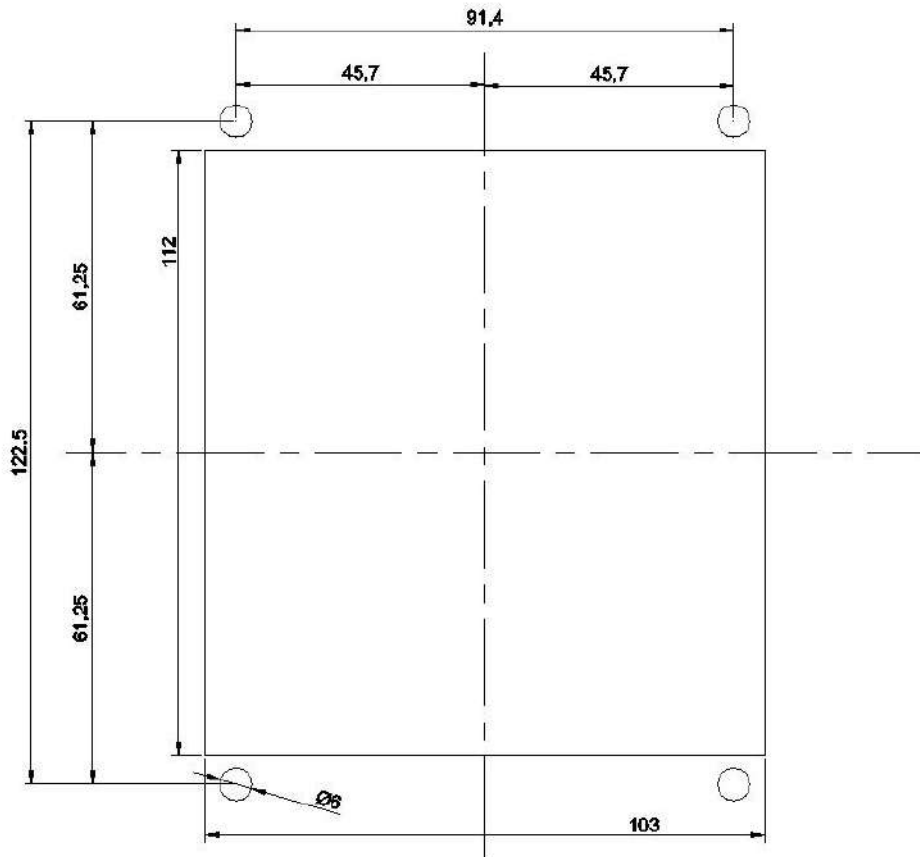
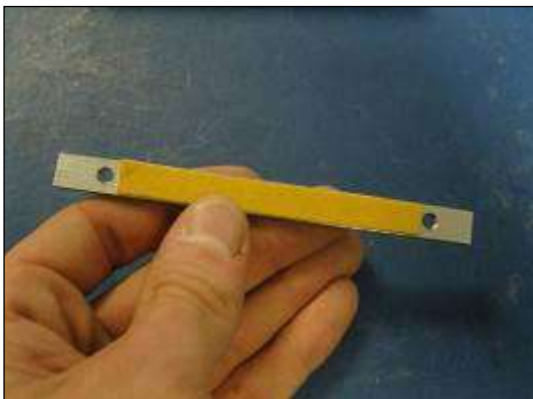

Figure 18 Panel mounting holes

4.1.3 Panel Mounting Procedure

- 1] To mount the panel variant instrument, take the two supplied brackets and remove the backing from the adhesive foam.



- 2] Place the brackets behind the panel and align the M5 holes with the 6mm holes in the panel, adhere the brackets to the rear of the panel with the adhesive foam.

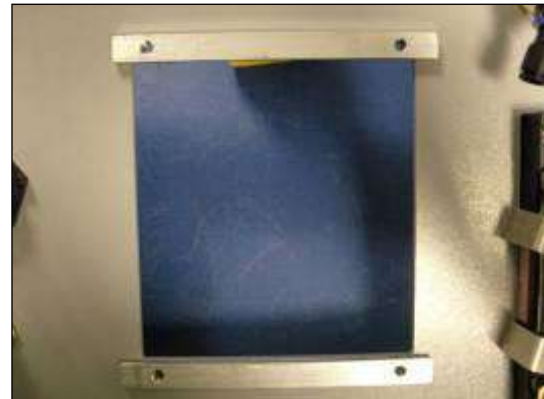

- 3] Align the instrument up to the panel and secure in place with the four provided M5x25mm Pozi-Pan screws.



4.1.4 The Combined Panel Adaptor Mounting Procedure

A combined panel mount adaptor plate kit (XK0-445K) is also available as an accessory to mount a rack mount CO₂ variant into an existing combined panel cut out.

This can be mounted to the panel as per the steps below.

- 1] Remove the rack mount fixings from the monitor and CO₂ module
- 2] Place the monitor into the adaptor plate (left hand side) and align with the four tapped M3 holes
- 3] Secure the monitor in place with four of the provided M3x8mm Pozi-Pan screws and M3 Nordlock washers
- 4] Place the CO₂ module through the remaining space and align with the remaining four tapped M3 holes
- 5] Secure in place with the remaining four M3x8mm Pozi-Pan screws and M3 Nordlock washers
- 6] Finally, secure the assembly into your panel using the provided M5x25mm Pozi-Pan screws and M5 captive nuts.

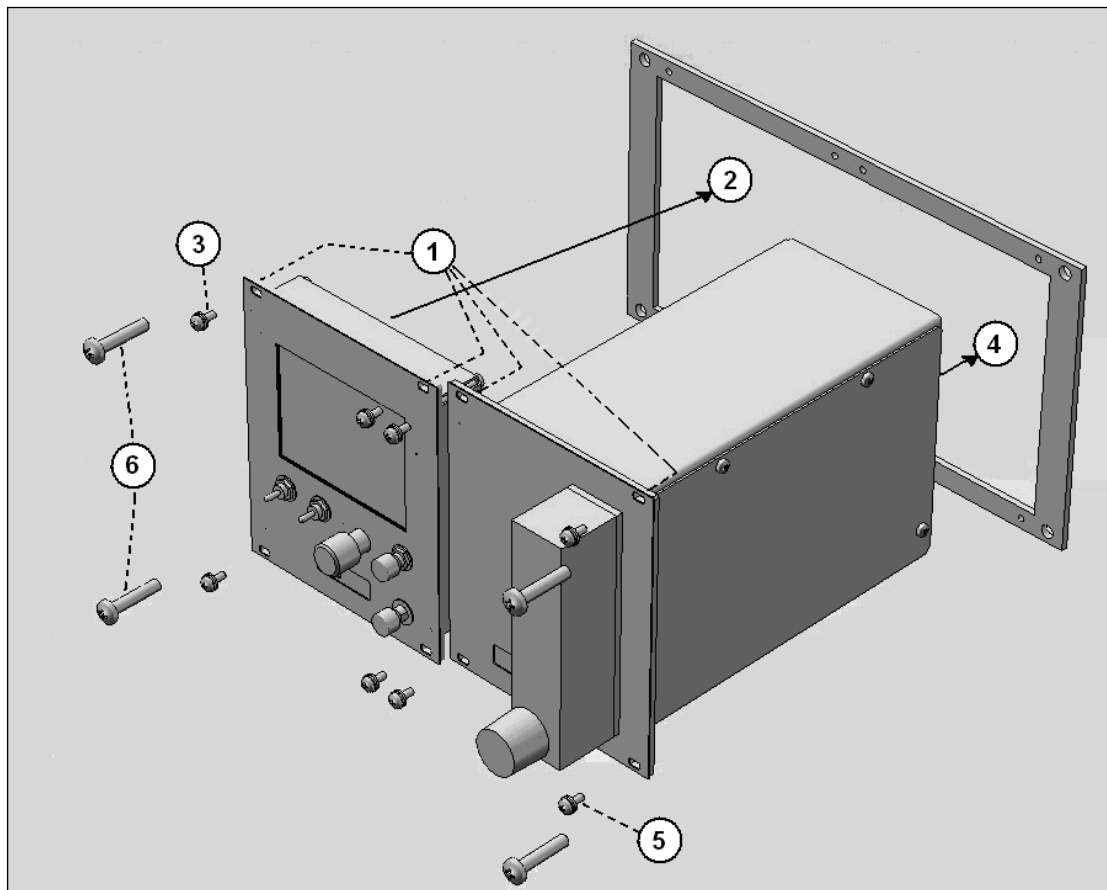

Figure 19 Building the combined panel

4.2 Monitor and Sensor Wiring

4.2.1 Monitor Connectors Overview

The SDA Monitor provides the connectors for all the system interconnections at the rear of the unit as shown in the figure below.

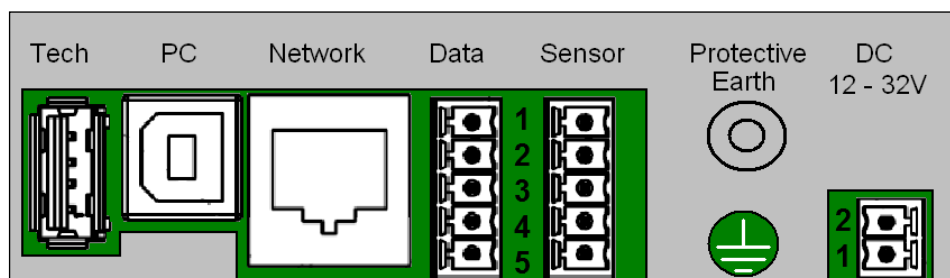

Figure 20 SDA monitor rear connectors

PC Communication

Connector	Description
Tech – USB Type A socket	Reserved
PC – USB Type B socket	USB connection to a PC. Used for configuration and downloading historic data (optional).
Network – RJ45 socket	Ethernet connection for networking functionality.

Sensor and Peripheral Connectors

Connector	Pin	Function	Comments
Monitor Data Phoenix MVC 5 way (3.5mm pitch)	1	V+	+5V DC supply output used to power the SDA Output Module (max 390mA).
	2	RS485 A	Differential TxD-/RxD- aka inverting pin
	3	RS485 B	Differential TxD+/RxD+ aka non-inverting pin
	4	RS485 Ref	Common reference signal to connect to remote RS485 device. If not required, it should be connected to pin 5 (0V).
	5	V-	0V DC connection for the supply output
Monitor Sensor Phoenix MVC 5 way (3.5mm pitch)	1	V+	+5V DC supply output used to power an SDA sensor (max 390mA).
	2	RS485 A	Differential TxD-/RxD- aka inverting pin
	3	RS485 B	Differential TxD+/RxD+ aka non-inverting pin
	4	RS485 Ref	Common reference signal to connect to remote RS485 device. If not required, it should be connected to pin 5 (0V).
	5	V-	0V DC connection for the supply output
Protective Earth	M4 Stud	Chassis Earth	Connects the system casework to the local protective earth. Sensor cable shields are also connected here.
Monitor Power Phoenix MVC 2 way (3.5mm pitch)	1	Vin+	Supply input +12 V DC to +32 V DC. (15 W maximum, 3 W typical)
	2	Vin-	Supply input 0V DC

4.2.2 Sensor and Data Wiring

The Sensor connector provides the power and communication link to any SDA sensor attached. The Data connector will automatically control the SDA Output module if attached otherwise this port will revert to a continuous data output stream that can be utilised by other third-party equipment for data logging purposes. See section 5.8 for detail on connection baud rate and data formats.

The wiring for both sensor and output module should follow the arrangement in the following figure:

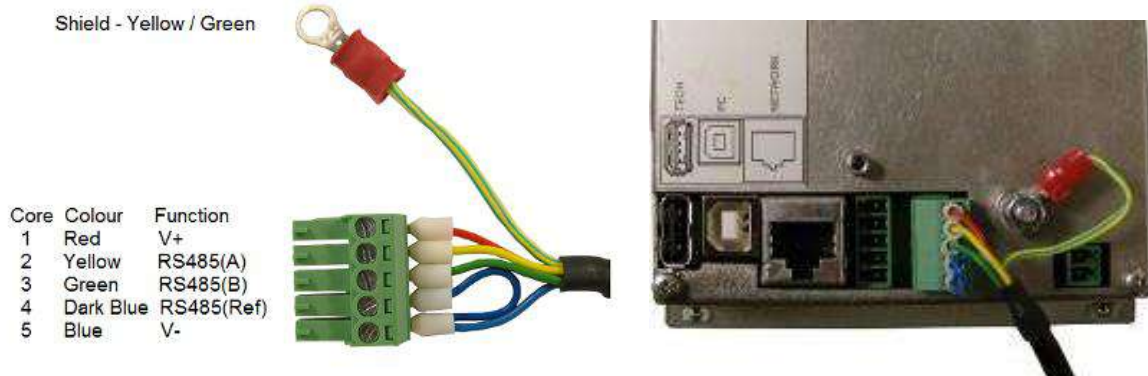

Figure 21 Sensor wiring



NOTE: IF THE APPLICATION REQUIRES THE RS485 TO BE ISOLATED DO NOT FIT THE LOOP CONNECTING "RS485(REF)" AND "V-" E.G. TO PREVENT GROUND LOOP ISSUES.



NOTE: FOR TEMPERATURE & HUMIDITY PROBE WIRING, WIRE COLOURS ARE DIFFERENT AS SHOWN BELOW, BUT THE FUNCTIONS ARE THE SAME.

Core	Colour	Function
1	Green	V+
2	Red	RS485(A)
3	Blue	RS485(B)
4	Grey (White Bootlace)	RS485(REF)
5	Grey (Blue Bootlace)	V-



4.2.3 The Power Connection

The monitor can be directly powered from a DC source, using the supplied two-way Phoenix connector as shown in the steps below.

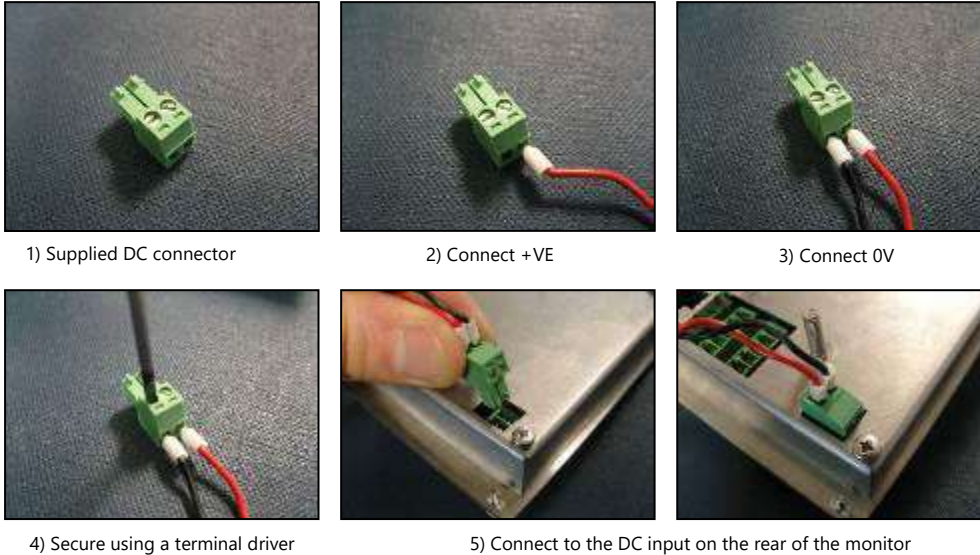

The monitor can also be powered from an AC source. The AC adaptor (XK0-667) can be purchased as an accessory from Analox, this is only suitable for UK 230VAC mains power, this will connect directly into the DC input on the rear of the monitor.

To change plug type on this PSU follow the steps below.



- 1] Select the correct plug head for your location, align the tabs on the rear of the plug head with the slots on the PSU (The plug head will only fit one way), then slide the plug head away from the cable.

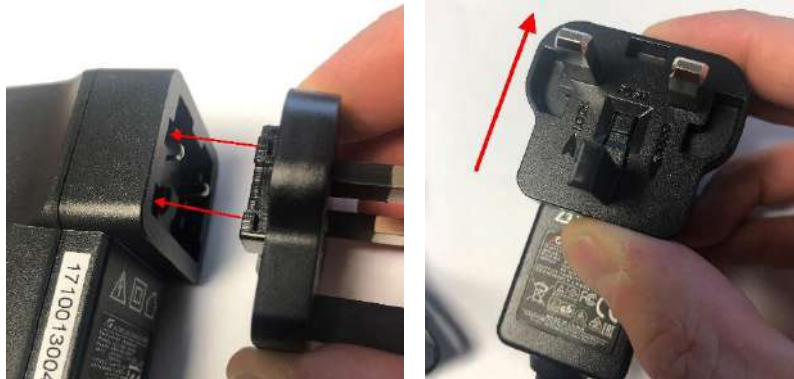

- 2] To swap plug heads, push the button in the centre of the plug head and slide it towards to cable.

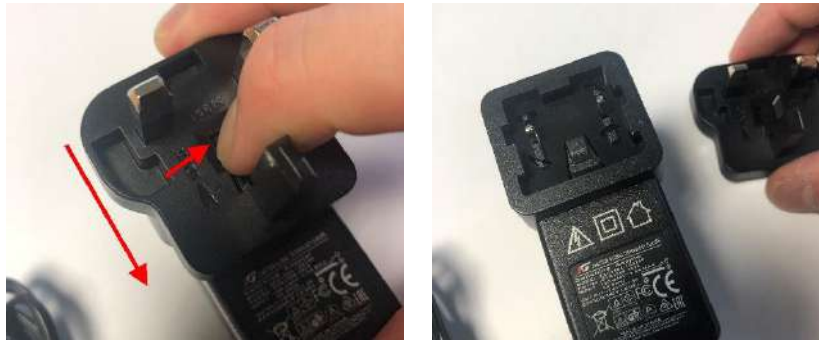

This can now be connected directly into the SDA as shown in section 4.2.3 step 5

To power two SDA monitors from one power supply, the following steps should be followed:



Cut a suitable length of 7/0.2mm red/black twisted wire



Remove the 2 way connector and bootlace ferrules from the cable and strip back 7mm



Twist the red wire with the white wire and then the two black wires together as shown and crimp with red and black 1.5mm bootlace ferrules as shown



Crimp the free end of the red/black twisted wires with red and black 1.5mm bootlace ferrules and connect to the two way connector supplied with the SDA



Connect the linked end to the remaining two way connector as shown



The PSU is now ready and can be connected to two SDA monitors as described in section 2.2.2 step 5

4.2.4 Protective / Chassis Earth



CAUTION: THE M4 STUD NEXT TO THE POWER CONNECTION MUST BE CONNECTED TO THE LOCAL CHASSIS / PROTECTIVE EARTH TO PROVIDE ESD AND SURGE PROTECTION. THIS STUD ALSO PROVIDES THE SHIELD CONNECTION TO THE SENSOR AND DATA PORT CABLES AND IS REQUIRED TO MAINTAIN EMC PERFORMANCE.

4.2.5 Depth SDA pressure sensor power

The pressure sensor (Active type) supplied with a depth SDA requires an external 24VDC supply. This can be powered through the supplied MEC 4-20mA module using the flying lead coming from the module, this should be connected to the same terminal of the 2-way screw terminal block as the 24VDC wire for the system as shown, the earth lead coming from the Bulgin cable connector should be fitted to the M4 stud and secured with the M4 nut as shown.

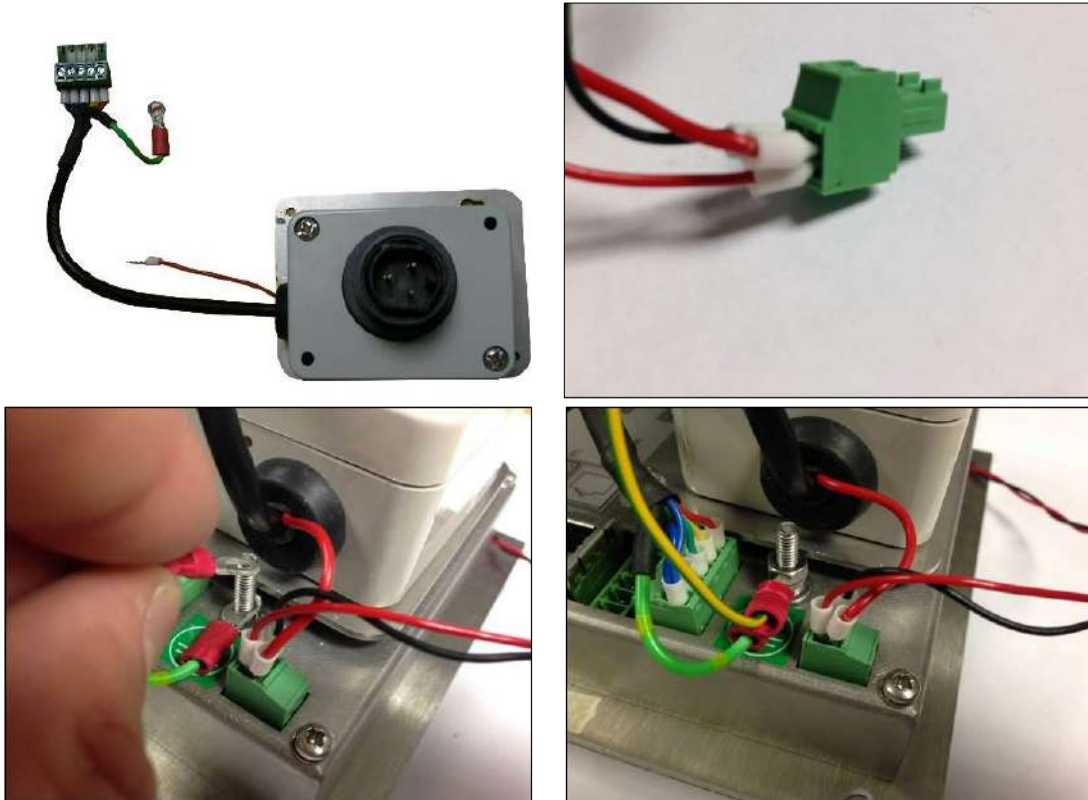

4.3 Output Module Wiring

The SDA output module can be connected to the Data port on the SDA Monitor to provide an analogue output of the sensor reading and the status of the alarms on the volt free contact relays.

4.3.1 Output Module Connections Overview

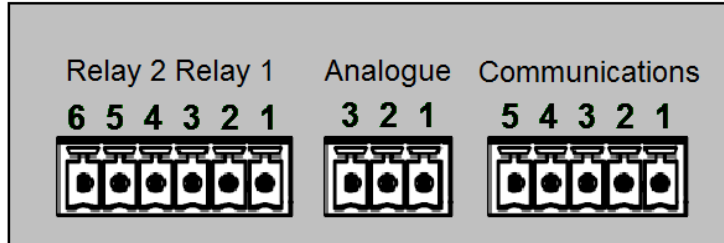

Figure 22 SDA output module connectors

Connector	Pin	Function	Comments
Communications Phoenix 5 way (3.5mm pitch)	1	V+	+5V DC supply input used to power the SDA Output Module (max 300mA).
	2	RS485 A	Differential TxD-/RxD- aka inverting pin
	3	RS485 B	Differential TxD+/RxD+ aka non-inverting pin
	4	RS485 Ref	Common reference signal to connect to SDA Monitor (not used).
	5	V-	0V DC connection for the supply output
Analogue Phoenix 3 way (3.5mm pitch)	1	Sink-	Passive analogue current connection
	2	Com	Common analogue current connection
	3	+Src	Active analogue current connection
Relays Phoenix 6 way (3.5mm pitch)	1	NC	Relay 1 Normally Closed (NC) contact
	2	COM	Relay 1 common
	3	NO	Relay 1 Normally Open (NO) contact
	4	NC	Relay 2 Normally Closed (NC) contact
	5	COM	Relay 2 common
	6	NO	Relay 2 Normally Open (NO) contact



For greater EMI immunity Analox recommend fitting ferrites to the cables (see above).
 Relay and 4-20mA = Wurth 742 712 22S, 1 cable turn
 Power and RS485 = Wurth 742 711 31S, 1 cable turn

4.3.2 Analogue Output

The analogue output may be configured by wiring to either the current sink (passive) or to the current source (active). When configured as an active source the default drive voltage is nominally +13V DC.

By use of a suitable load resistor with the active source connection, the unit may provide a voltage output with full scale output configurable to over +12V DC depending on the value of the resistor used. For 0-1V output, the resistor would be 50R, for 0-2V use 100R etc.

If an external current source is used, the unit should be wired as a current sink using pins 1 and 2, with the negative of the external source connected to pin 1. The drive voltage of the external source should be no more than 48V due to the overvoltage protection diodes, but the unit only requires a compliance voltage of less than 1V to properly control the output current.

If an external current sink is used (e.g., a simple analogue meter), the unit should be wired as a current source using pins 2 and 3. In this case, the positive of the source is on pin 3. The resistance of the external sink must be considered; as standard the unit is configured to drive an external resistance up to at least 550R (greater than 12V compliance voltage).

4.3.3 Relay Outputs

There are two identical controllable relay outputs with a single change-over contact each, with the COM (common) line connected to either NO (normally open) or NC (normally closed).

For true failsafe the NO-COM contact pair can be used to indicate an OK state when closed, so that disconnections or open circuit cable faults will provide the fault state.

For details of the operational states of the relays when connected to an SDA see section 5.10.2.

4.4 Brackets

There are two brackets available for the SDA, one for only mounting the MEC oxygen sensor, the other will fit the sensor and output module as required.

4.4.1 Fitting the MEC-only bracket

The MEC only bracket (XK0-473K) is suitable for mounting the MEC sensor to the rear of the monitor. The MEC sensor must be fitted to the bracket before fitting the bracket to the rear of the monitor. This is detailed in the steps below.



1) Bracket kit (XK0-473K)



2) Remove MEC lid



3) Insert M4 screw Screws



4) Replace MEC lid



5) Secure with 3mm Hex key & M4 Nyloc nuts

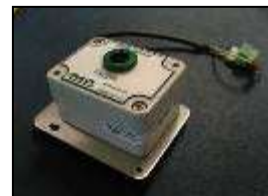

6) Finished assembly

The bracket and the MEC sensor can then be attached to the rear of the monitor as per the steps below.



7) Remove 2 x M3 x 6mm Pozi Pan Screws and Nordlock washers from rear of monitor



8) Align mounting hole with standoff



9) Secure bracket with 2 x M3 x 6mm Pozi-Pan Screws and Nordlock washers



10) Connect MEC sensor



11) Connect MEC sensor earth to earth stud

4.4.2 Fitting the combined MEC and output module mounting bracket

The combined MEC and output module bracket (XK0-472K), can be used to mount the MEC sensor and/or an output module. Mount the bracket to the monitor follow the steps below.



1) Remove 2 x M3 x 6mm Pozi Pan Screws and Nordlock washers from rear of monitor



2) Align mounting hole with standoff



3) Secure in place with the 2 x M3 x 6mm Pozi Pan Screws and Nordlock washers from rear of monitor

4.4.3 Fitting the MEC sensor to the rear of the bracket



1) Remove lid from MEC



2) Insert the supplied M4 cap screws into each mounting hole



3) Replace MEC lid



4) Align M4 cap Screws with standoffs



5) Tighten the M4 cap Screws with a 3mm hex key



6) Connect the MEC sensor



7) Connect MEC sensor earth to earth stud

4.4.4 Fitting the SDA output module to the bracket



1) Remove lid from output module



2) Insert the supplied M4 x 8mm Pozi-Pan Screws into each mounting hole



3) Align screws with standoffs



4) Tighten the M4 Pozi Pan screws



5) Replace lid on output module



6) Connect output module cable



7) Connect output module earth to earth stud

4.4.5 Completed assembly of combined MEC and power supply mounting bracket

Figure 23 shows an overview of the combined bracket fitted with the MEC sensor, AC power supply and SDA output module.

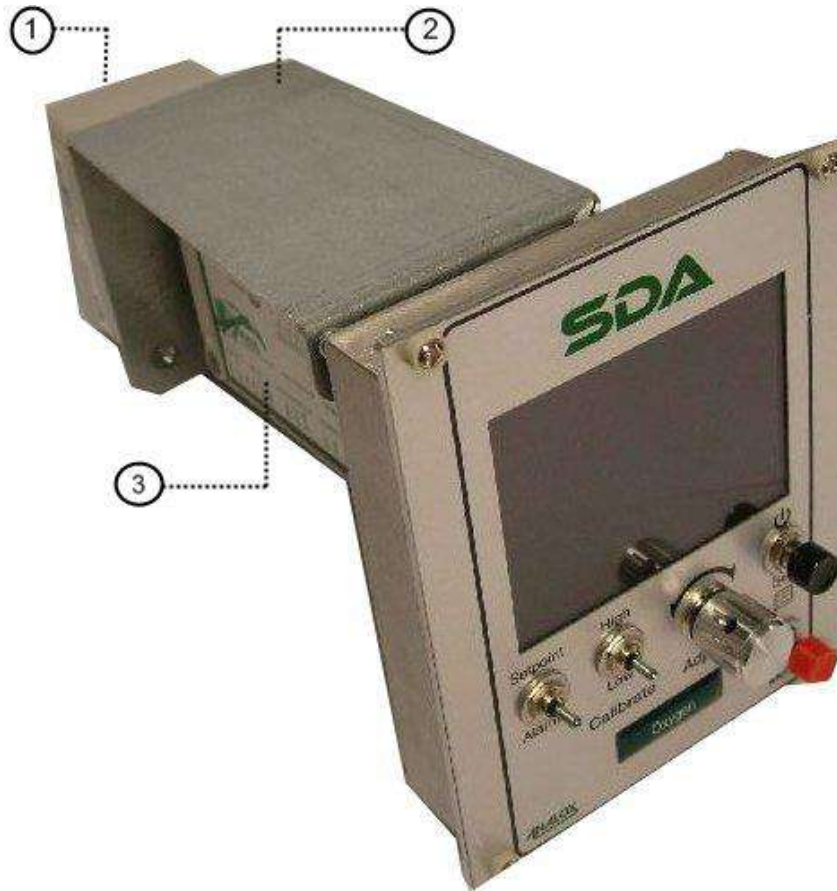

Figure 23 *Assembly with the combined mounting bracket*

- 1) MEC sensor
- 2) Bracket
- 3) Optional output module

4.5 Pipe work



CAUTION: EXHAUST LINES CAN PRODUCE BACK PRESSURE AT THE SENSOR WHICH WILL AFFECT THE SENSOR READING. KEEP THIS LINE AS SHORT AS POSSIBLE, E.G. LESS THAN 150 MM. IT IS ACCEPTABLE TO USE NO EXHAUST TUBE IF IT IS APPROPRIATE FOR THE TYPE OF SAMPLE GAS. THE PRESSURE OF THE SAMPLE GAS MUST BE CLOSE TO THE AMBIENT PRESSURE OTHERWISE DAMAGE MAY OCCUR TO THE SENSORS AND SENSOR ACCURACIES WILL BE AFFECTED. THE INLET FLOW RATE TO THE SENSORS MUST BE BETWEEN 0.2 TO 1.0 L/MIN, 0.5 L/MIN IS RECOMMENDED. WHEN SDA FLOW METERS ARE USED THE INPUT PRESSURES TO THE METER MUST NOT EXCEED 6 BARA.

4.5.1 MEC sensor pipe work

The MEC sensor is supplied with a two-port flow adaptor. The tubing should be trimmed to the correct length then the flow adaptor removed to fit the tubing onto the spigots.



1) Connect pipe work to flow adaptor as shown



2) Connect flow adaptor to the inlet of the MEC sensor



The MEC sensor sample input line can also be piped to a dedicated SDA flow panel or connected to the exhaust of the SDA CO₂ sensor module.

4.5.2 Carbon dioxide sensor module pipe work

The CO₂ sensor module should be connected as per the following steps.



1) Remove bulkhead pipe securing nuts



2) Fit securing nuts to pipes



3) Fit Gas Input and Exhaust pipework to bulkheads



4) Secure pipe work in place with securing nuts



5) Finished connections

5 Operation

5.1 Start-up

An SDA will automatically start up when power is supplied to it. The SDA will display the splash screens shown below. The SDA will show a blank screen during warm prior to displaying the main screen as described in section 5.2.1. Warm-up is normally expected to take up to 15 seconds.

Additionally, upon start-up, an attached sensor may require a short time to warm up as described in section 5.3.2.

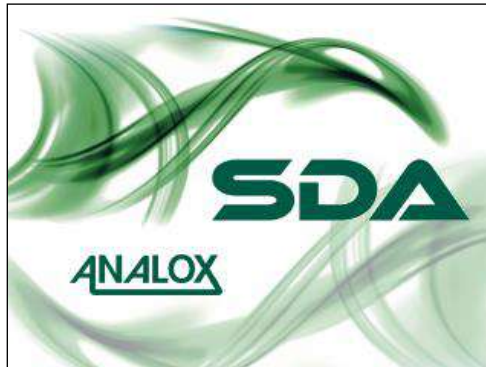

Figure 24 *Start-up splash screen (Pre-February 2017)*



Figure 25 *Start-up splash screen (Post February 2017)*

5.2.1 Main display screen

Under normal operation the SDA will display its main display screen (**Figure 26**) that reveals the elements of the main screen for a single sensor SDA.

Figure 27 explains the elements of a dual sensor SDA.

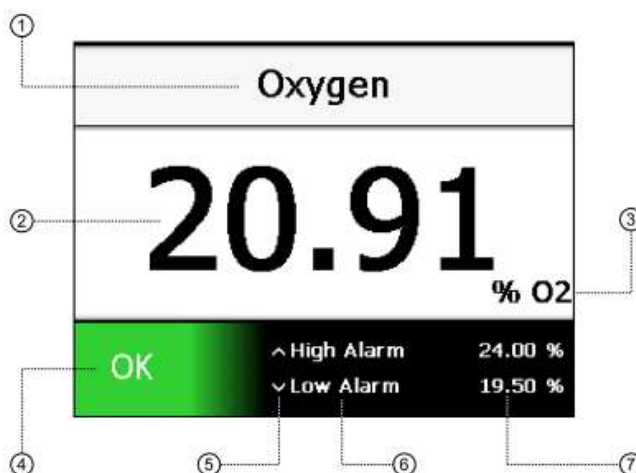

Figure 26 Main display overview (Single sensor)

- 1) Device identification label
- 2) Live sensor reading
- 3) Sensor type and display units
- 4) System status indicator
- 5) Alarm direction indicators
- 6) Alarm names
- 7) Alarm set-points

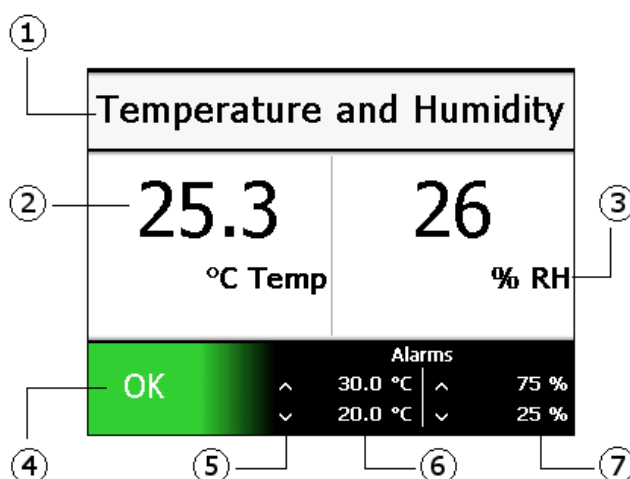

Figure 27 Main display overview (Dual sensor)

- 1) Device identification label
- 2) Live sensor reading

- 3) Sensor type and display units
- 4) System status indicator
- 5) Alarm direction indicators
- 6) Sensor 1 alarm values
- 7) Sensor 2 alarm values

5.2.2 System status indicator

The system status indicator shows the current status of the SDA system. If any alarm condition has been identified, then the system status indicator will turn red and display the word 'Alarm'. If any system fault is identified, then the status indicator will turn yellow and display the word 'Fault'. In no current alarm or fault conditions have been identified then the system status indicator will turn green and display the word 'OK'. **Figure 28** shows the different system status indicator states.



Figure 28 System status indicator

5.2.3 Device identification label

At the top of the main display screen is the device identification label. By default, this label indicates the type of SDA as shown in **Figure 29**

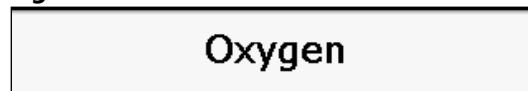

Figure 29 Default device identification label for an SDA – O₂

An SDA can be configured using the SDA software to display a custom identification label. This can be used to help identify individual units in a large panel.

Figure 30 shows an example of a custom identification label. For instructions on how to configure the identification label see section 6.3.1.

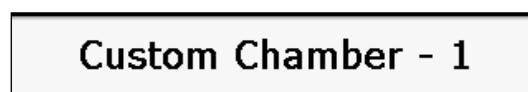

Figure 30 Example of a custom identification label

5.3 Sensor readings

5.3.1 Sensor reading update

When a sensor is attached to an SDA a live reading from the sensor will be displayed in the centre of the main display. This reading will be updated on the display once per second. If no valid sensor reading is currently available, then three dashes ('---') will be shown instead.

5.3.2 Sensor warm-up

Under certain circumstances, when the digital sensor attached to the SDA cannot display a valid reading then the display will show that the sensor is in a warm-up state. Warm-up occurs when the SDA is initially powered up and may last 10 to 60 seconds depending on the sensor type attached. Under certain circumstances the sensor may enter a warm-up state whilst it processes information such as after a calibration adjustment has been attempted or when a sensor is re-connected after being disconnected. Whilst in a warm-up state, the display reading is shown as three dashes ('---') and a warm-up processing animation is displayed (**Figure 31** Example of a sensor that is in a warm-up state

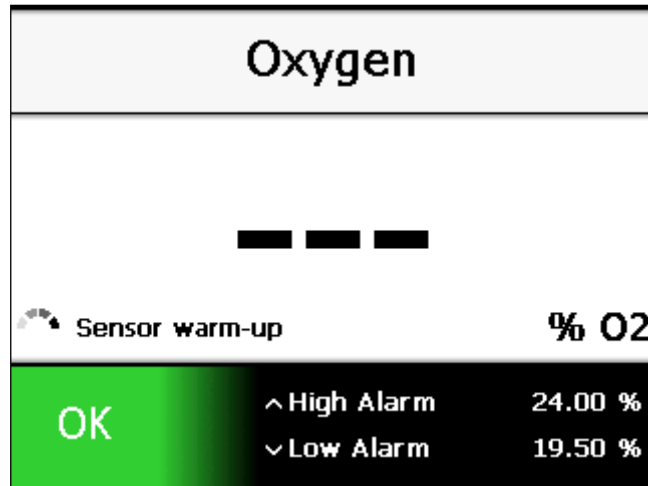

Figure 31 Example of a sensor that is in a warm-up state

5.4 Alarms

Each SDA comes with two alarms defined for each sensor attached. Each alarm is defined by a set-point and a direction. The name, set point and direction of both alarms are shown on the main display screen as shown in **Figure 26** and **Figure 27**. **Figure 27 Main display overview (Dual sensor)** Every second, as the sensor reading is updated, each alarm is checked against the current reading. For high-going direction alarms, an alarm condition will be triggered if the sensor reading is greater than the alarm set-point. Conversely, for low-going direction alarms, an alarm condition will be triggered if the sensor reading is less than the alarm set-point.

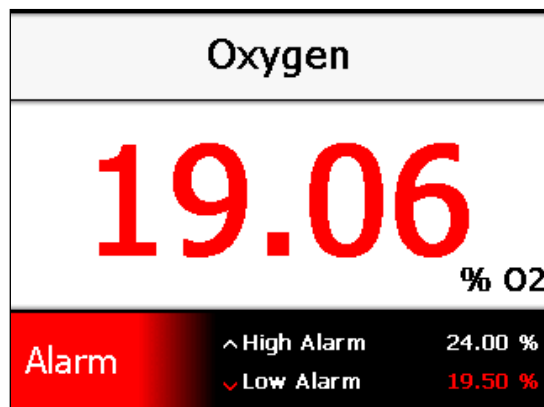

Figure 32 A low-going alarm that has been triggered

When an alarm condition is identified the horn will immediately sound and the system status indicator will flash, coloured red, showing the word 'alarm'. In addition, the sensor reading will be displayed, coloured red, and the set-point for the alarm that has been triggered will be highlighted. **Figure 32** shows an example of a low-going alarm that has been triggered by a low oxygen reading.

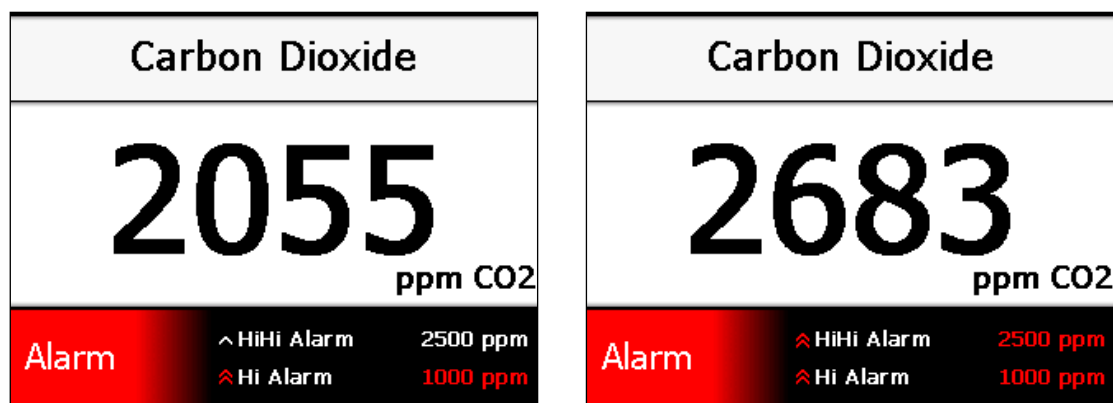

Figure 33 Example of two high-going alarms

In cases where two alarms with the same direction are defined, the horn and alarm status will be triggered when the first alarm condition is met. If the sensor reading continues in the same direction and the second alarm condition is met, then both alarm conditions will be shown as triggered. **Figure 33** shows an example of two high-going carbon dioxide alarms.

If the first alarm is triggered and the horn is subsequently muted, the horn will be re-activated if the second alarm is triggered.

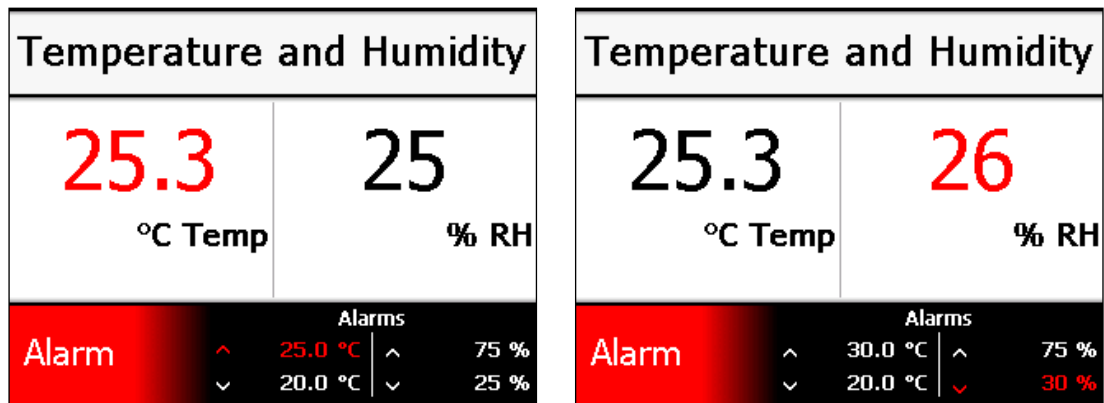

Figure 34 Example of active alarms on dual sensor system

5.4.1 Muting alarms

When an alarm condition is triggered and the horn sounds, the horn can be muted by pressing the red mute button. This will mute the horn on all occasions where the horn is activated. In addition, when an alarm is muted, the system status indicator on the display will stop flashing and will instead be shown in solid red to indicate that the alarm has been acknowledged.

5.4.2 Clearing alarms and hysteresis

To avoid nuisance re-triggering of alarms when a sensor reading is fluctuating around an alarm set-point, each alarm has a hysteresis band applied to it. This hysteresis applies to the clearing of an already triggered alarm. An alarm will always trigger immediately when the sensor reading passes the set-point in the correct direction. However, when the sensor returns in the opposite direction through the same set-point, it must go an amount beyond the set-point before the alarm will clear. This extra amount required to clear an alarm is the alarm's hysteresis. **Figure 35** shows an example of a hysteresis band on a high going alarm.

The hysteresis applied to an alarm is adjusted automatically based on the value of the alarm set-point. Hysteresis for each sensor range is defined by a percentage of set-point and a maximum hysteresis value. The hysteresis applied to the alarm is the smaller of the two values for a particular set-point.

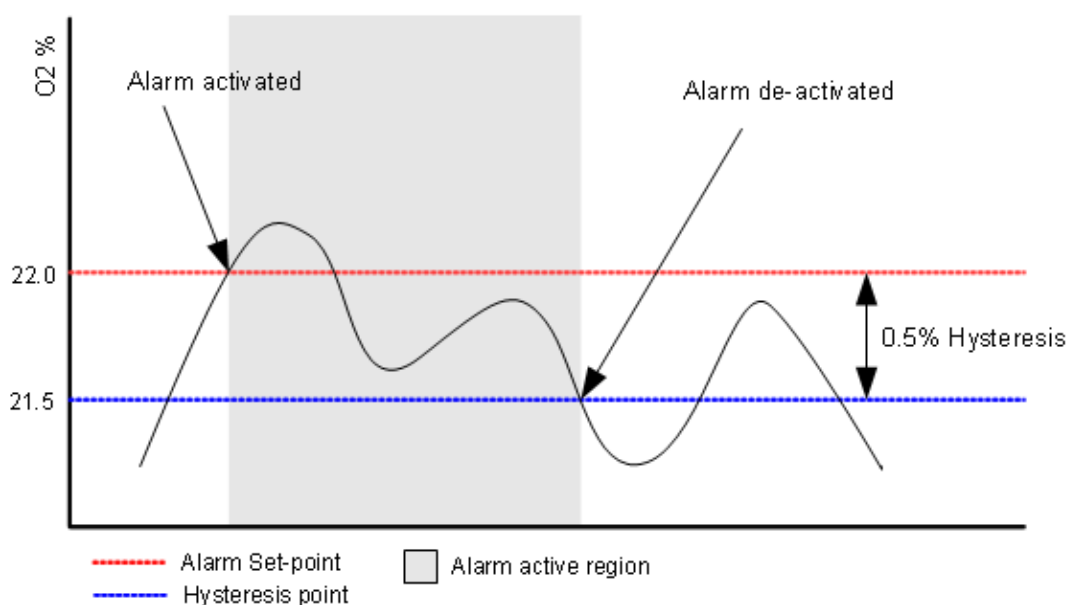

Figure 35 Hysteresis band on a high going oxygen alarm

5.4.3 SDA Depth (ROC) alarms

There are two ROC alarms per SDA, a fast ROC alarm set to activate at a specified msw / minute level and a slow ROC alarm which has a set-point at a specified msw / hour reading. The two alarms annunciate an audio / visual alarm at the monitor.

5.4.4 Latching alarms

Alarms can operate in either latching or non-latching mode.

With latching alarms **disabled**, if an alarm is triggered and sensor reading subsequently returns to a level that would not trigger the alarm, the visual and audio indicators will be cancelled as soon as the reading passes the hysteresis point (see section 5.4.2).

With latching alarms **enabled**, if an alarm is triggered and the sensor reading subsequently returns to a level that would not trigger the alarm, the visual and audio indicators will continue until the mute button is pressed to acknowledge the alarm. Once acknowledged, the visual and audio indicators will be cancelled. Whilst latching is **enabled**, if an alarm is acknowledged by pressing the mute button prior to the sensor reading passing back through the alarm set-point then the visual and audio indicators will be cancelled as soon as the reading passes the hysteresis point (see section 5.4.2).

For instructions on how to set the latching alarms option see section 6.3.1.

5.4.5 Alarm reminders

In situations where it is important that alarm conditions are not missed, the alarm reminder feature can be enabled. Reminders will re-trigger the horn for an alarm condition if the condition is not cleared after a specified time. The horn will be re-triggered even if it has previously been muted. The horn will not be retriggered once the sensor reading reaches a level that no longer triggers the alarm.

For instructions on how to set the alarm reminder option and reminder timeout see section 4.3.2.

5.4.6 Adjusting alarm set-points

Each of the SDA's alarm set-points can be individually adjusted to suit the monitoring application. To adjust a set-point, first select the alarm to adjust by pushing and holding the alarm-adjust toggle switch in the direction of the chosen alarm (up for higher alarm, down for lower alarm - **Figure 36**).



NOTE: FOR DUAL SENSOR DEVICES, THE LEFT TOGGLE SWITCH IS USED TO ADJUST THE FIRST SENSOR'S ALARMS AND THE RIGHT TOGGLE SWITCH IS USED TO ADJUST THE SECOND SENSOR'S ALARMS.



NOTE: THE ALARM-ADJUST TOGGLE SWITCH MUST BE HELD IN THE CHOSEN STATE UNTIL THE NEW SET-POINT IS CONFIRMED. RELEASING THE SWITCH PRIOR TO CONFIRMATION WILL RETURN THE SET-POINT TO ITS ORIGINAL VALUE.

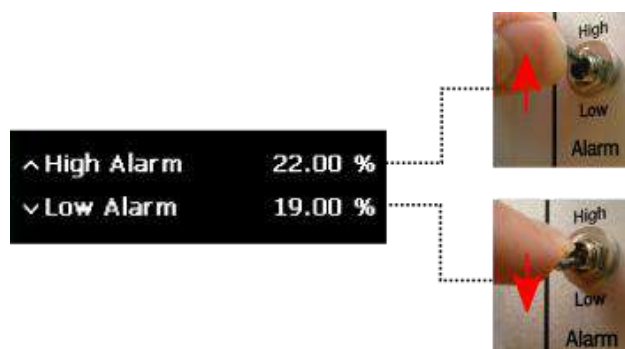

Figure 36 Selecting an alarm to adjust

When the alarm-adjust toggle switch is held in the adjustment position, the alarm adjustment panel will be shown in place of the alarm set-points panel (**Figure 37** ①) showing the name of the alarm to be adjusted and the current alarm set-point, coloured yellow.

Using the adjustment knob, the set-point can be adjusted by rotating the knob clockwise to increase the set-point and anti-clockwise to decrease the set-point (**Figure 37** ②).

Once the desired new set-point is shown, press the set button to confirm the value. Once confirmed the set-point number displayed will turn green (**Figure 37** ③). Once the new set-point is confirmed, alarm-adjust toggle switch can be released. The alarm set-points panel will return to the screen showing the new value for the alarm set-point which was adjusted.



Figure 37 Example of alarm set-point adjustment

5.4.7 Calibration adjustment

Whilst in use, an SDA's sensor should be periodically calibrated at intervals deemed necessary for the monitoring application by exposing the sensor to gas of a known concentration. Calibration adjustments of the sensor's output can be made where necessary as follows.



NOTE: FOR CERTAIN SENSORS (SUCH AS THE TEMPERATURE AND HUMIDITY SENSOR), IT IS NOT POSSIBLE TO PERFORM A USER CALIBRATION ADJUSTMENT. WHERE THIS IS THE CASE, THE CALIBRATION FEATURE WILL NOT BE AVAILABLE FOR THE SENSOR.

Each sensor's output is defined by two calibration points, one low and one high. To perform a successful calibration adjustment, both low and high calibration points should be adjusted.



NOTE: THE HIGH AND LOW CALIBRATIONS PERFORMED ON A SENSOR SHOULD BE SELECTED APPROPRIATELY. SOME SENSORS (E.G. CARBON DIOXIDE) REQUIRE THAT THE LOW CALIBRATION IS A TRUE ZERO CALIBRATION ADJUSTMENT. FOR THESE SENSORS, A GAS WITH A KNOWN ZERO CONCENTRATION OF THE TARGET GAS SHOULD BE USED. FOR OTHER SENSORS WHERE THE LOW CALIBRATION ADJUSTMENT IS NOT RESTRICTED, A HIGH AND LOW CALIBRATION ADJUSTMENT VALUE SHOULD BE SELECTED. THE SELECTED GAS CONCENTRATIONS SHOULD BEST REFLECT THE RANGE OVER WHICH THE SENSOR IS INTENDED TO BE USED FOR GREATER READING ACCURACY.



NOTE: WHEN CALIBRATING THE CO SENSOR, CARE SHOULD BE TAKEN WHEN SELECTING THE CALIBRATION GAS USED. THE BALANCE OR BACKGROUND GAS CAN HAVE AN EFFECT ON THE SENSOR READING. SEE SECTION 3.3.4.1 FOR DETAILS OF CALIBRATION GAS SELECTION FOR CO VERSION.

Typically, a % oxygen sensor (MECO2ABBP) monitoring a sample line in a saturation diving scenario, at a depth of 200msw, and maintaining an oxygen partial pressure of 400mbar ppO₂, the analyser is expected to read 1.90%. Therefore, the high calibration gas in such a case is likely to be chosen between 3 and 5% oxygen in helium, which ensures that the analyser is calibrated close to the point of interest. It is vital that at shallower depths, the analyser is recalibrated, since any errors at this calibration point will be magnified at shallower depths, when the oxygen content is higher. Note that the MEC and the SDA CO₂ sensor modules contain an atmospheric pressure sensor which will automatically compensate for pressure effects on the gas during calibration (observe safety warnings on helium ingress, see section 1.3).

To calibrate the partial pressure oxygen sensor (MECO2ABAP) the operator must enter the correct partial pressure gas value at the SDA Monitor. If the sensor is in a hyperbaric atmosphere, for example in a Saturation Dive Chamber this value may be derived from other sensors monitoring the chamber. If the sensor is at atmospheric pressure and bottled calibration gas is used, then the certified partial pressure value of the calibration gas must be calculated by the operator when the calibration step is

performed. Note that the partial pressure MEC O₂ sensor does not include automatic atmospheric pressure compensation.

A gas containing 50% O₂ would be equivalent to 500mbar at the sensor under exactly 1bar atmosphere. The operator must adjust the calibration value according to the current atmospheric pressure, so for this gas if the pressure is 1017mbar, (1.017bar) then multiplying 500mbar by 1.017 will determine that 508.5mbar of O₂ will be present at the sensor. The operator can enter this compensated value during the calibration step, see below.

5.4.8 Performing a gas calibration adjustment

To perform a calibration adjustment, first expose the sensor to the appropriate calibration gas of known concentration. The sensor should be allowed to settle for a period of time so that the sensor reading can stabilise. This will depend on both the settling time of the sensor and on the length of pipe-work and the flow rate of gas between the gas source and the sensor.

Once the sensor reading has settled for the applied calibration gas, the calibration adjustment can begin by pushing and holding the Calibration toggle switch in the direction of the calibration point to be adjusted (up for high calibration adjustment, down for low calibration adjustment).

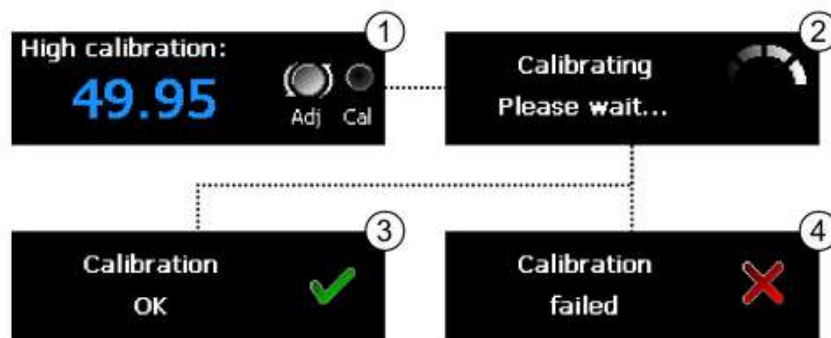

Figure 38 Gas calibration adjustment

With the toggle switch held, the calibration value entry panel will be shown (**Figure 38** ①) with the value coloured blue. Rotating the adjustment knob allows the calibration value to be increased or decreased. The adjustment knob should be rotated until the known concentration of the calibration gas is displayed.



NOTE:

THE CALIBRATION VALUE THAT CAN BE ENTERED IS LIMITED TO ZERO AS A MINIMUM VALUE AND THE MAXIMUM RANGE OF THE SENSOR PLUS 10% FOR THE MAXIMUM CALIBRATION VALUE. FOR CERTAIN SENSORS (E.G. CARBON DIOXIDE) THE LOW CALIBRATION MUST BE PERFORMED WITH ZERO CONCENTRATION OF THE TARGET GAS. IN THESE CASES, THE CALIBRATION ADJUSTMENT VALUE CANNOT BE CHANGED BY ROTATING THE ADJUSTMENT KNOB AND THE DISPLAY WILL SHOW THE WORD 'ZERO'.

To begin the calibration adjustment process, press the set button. If the calibration toggle switch is released at any time before the set button is pressed, then the adjustment will be aborted.

Once an adjustment has begun the sensor will take a moment to process the adjustment request (**Figure 38** ②) and will decide whether the value supplied is reasonable. See troubleshooting (Section 7) for possible invalid calibration conditions.

If a calibration adjustment is accepted, then a 'Calibration OK' message will be shown (**Figure 38** ③).

Should an adjustment request be rejected then a 'Calibration failed' message will be shown instead

(Figure 38 ⁴). Both of these messages can be cleared by pressing the mute button.

After any calibration adjustment request is processed, the sensor may enter a warm-up state for a few seconds during which time the sensor reading will not be available.

**NOTE:**

THE CALIBRATION ADJUSTMENT WINDOW CAN ALSO BE ACCESSED FROM THE MAIN MENU. FOR DUAL SENSOR SYSTEMS WITH SENSORS THAT CAN BE USER CALIBRATED, THIS IS THE ONLY WAY TO ACCESS THE CALIBRATION ADJUSTMENT FEATURE.

5.4.9 Dual Display O₂ sensor calibration adjustment

Calibration of the dual display O₂ variant of SDA's is different to that of the standard O₂ SDA's as the toggle switches on the front of the unit are used to set alarms for each of the readings on the display.

To perform a Dual O₂ Display calibration adjustment, first expose the sensor to the appropriate calibration gas of known concentration. The sensor should be allowed to settle for a period of time so that the sensor reading can stabilise. This will depend on both the settling time of the sensor and on the length of pipework and the flow rate of gas between the gas source and the sensor.

Once the sensor reading has settled for the applied calibration gas, the calibration adjustment can begin by pressing the Set button to enter the menu, then rotating the adjustment knob until Calibrate is highlighted, Press Set again to enter the Calibration menu.

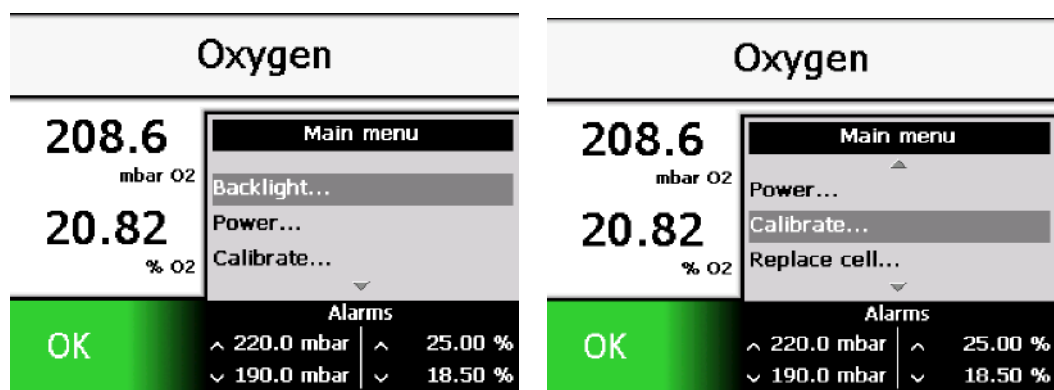

Figure 39 Entering the dual display calibration menu

Once in the calibration menu, there are two options, sensor 1 (mbar) or sensor 2 (%) depending on what values the user requires to calibrate in. Highlight the required sensor and press Set, then select either Low or High calibration (Analox recommend that a Low calibration is performed first).

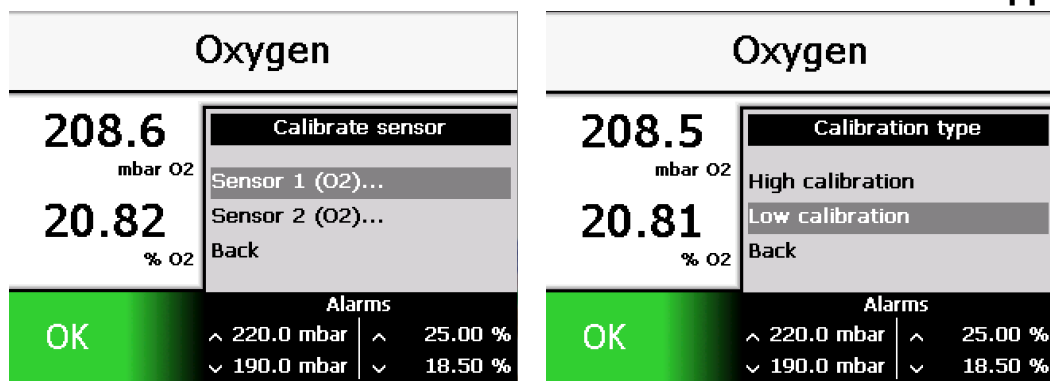

Figure 40 Selecting the sensor and type of calibration

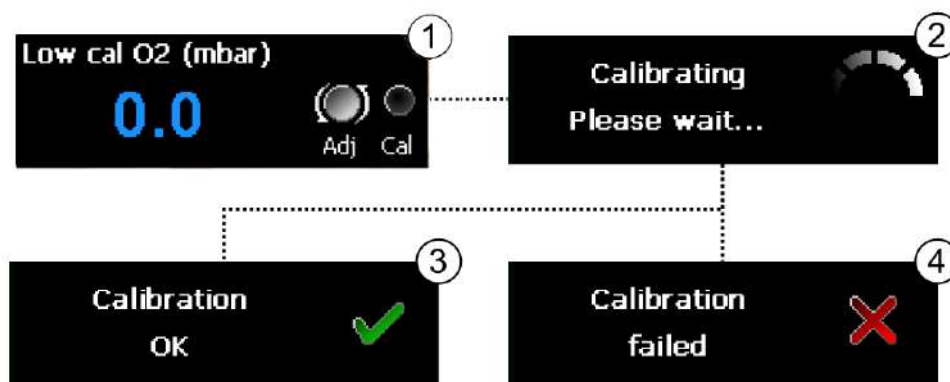

Figure 41 Low calibration gas adjustment (mbar)

With the Low or High calibration selected within the menu, the calibration value entry panel will be shown (Figure 41 ①) and the value coloured blue. Rotating the adjustment knob allows the calibration value to be increased or decreased. The adjustment knob should be rotated until the known concentration of the calibration gas is displayed.



NOTE:

THE CALIBRATION VALUE THAT CAN BE ENTERED IS LIMITED TO ZERO AS A MINIMUM VALUE AND THE MAXIMUM RANGE OF THE SENSOR PLUS 10% FOR THE MAXIMUM CALIBRATION VALUE.

To begin the calibration adjustment process, press the set button. If the mute button is pressed at any time before the set button is pressed, then the adjustment will be aborted.

Once an adjustment has begun the sensor will take a moment to process the adjustment request (Figure 41 ②) and will decide whether the value supplied is reasonable. See troubleshooting (Section 7) for possible invalid calibration conditions.

If a calibration adjustment is accepted, then a 'Calibration OK' message will be shown (Figure 41 ③)

Should an adjustment request be rejected then a 'Calibration failed' message will be shown instead

(**Figure 41** ) Both of these messages can be cleared by pressing the mute button.

After any calibration adjustment request is processed, the sensor may enter a warm-up state for a few seconds during which time the sensor reading will not be available.

5.4.10 Performing a pressure calibration adjustment



NOTE: ANALOX RECOMMEND A 2 POINT PRESSURE CALIBRATION SHOULD BE PERFORMED ON AN ANNUAL BASIS.



NOTE: IF WANTING TO MEET ACCURACY REQUIREMENTS OF DNV-OS-E402 THE SENSOR MUST BE CALIBRATED USING A KNOWN CERTIFIED REFERENCE, HAVING A THIRD PARTY CALIBRATE THE SENSOR USING THEIR OWN CERTIFIED EQUIPMENT OR THE SENSOR MUST BE RETURNED TO A KNOWN CERTIFIED BODY FOR CALIBRATION.

To perform a calibration adjustment, first expose the sensor to a known pressure. The sensor should be allowed to settle for a period so that the sensor reading can stabilise.

Once the sensor reading has settled for the applied pressure, the calibration adjustment can begin by pushing and holding the Calibration toggle switch in the direction of the calibration point to be adjusted (up for high calibration adjustment, down for low calibration adjustment).

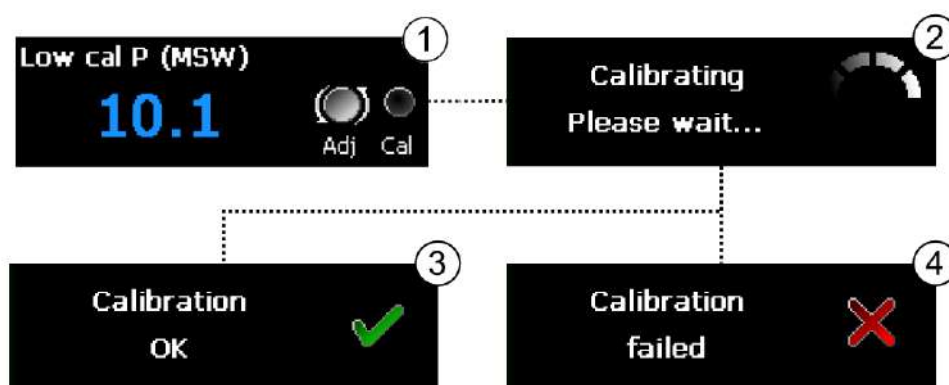

Figure 42 Pressure calibration adjustment

With the toggle switch held, the calibration value entry panel will be shown (**Figure 42** ①) with the value coloured blue. Rotating the adjustment knob allows the calibration value to be increased or decreased. The adjustment knob should be rotated until the known value of the calibration pressure is displayed.



NOTE: THE CALIBRATION VALUE THAT CAN BE ENTERED IS LIMITED TO ZERO AS A MINIMUM VALUE AND THE MAXIMUM RANGE OF THE SENSOR PLUS 10% FOR THE MAXIMUM CALIBRATION VALUE. ANALOX RECOMMEND THAT THE LOW CALIBRATION BE PERFORMED FIRST AT AMBIENT PRESSURE, THEN THE HIGH CALIBRATION BE PERFORMED AT A KNOWN PRESSURE.

To begin the calibration adjustment process, press the set button. If the calibration toggle switch is released at any time before the set button is pressed then the adjustment will be aborted.

Once an adjustment has begun the sensor will take a moment to process the adjustment request

(**Figure 42** ^②). Figure 38 Gas calibration adjustment and will decide whether the value supplied is reasonable. See troubleshooting (Section 7) for possible invalid calibration conditions.

If a calibration adjustment is accepted, then a 'Calibration OK' message will be shown (**Figure 42** ^③).

Should an adjustment request be rejected then a 'Calibration failed' message will be shown instead (**Figure 42** ^④). Both messages can be cleared by pressing the mute button.

After any calibration adjustment request is processed, the sensor may enter a warm-up state for a few seconds during which time the sensor reading will not be available.

5.4.11 Calibration adjustment reminders

For situations where regular calibration adjustments are performed, a useful reminder can be enabled using the SDA software. For instructions on how to enable and configure the calibration adjustment reminder feature see section 6.3.2.

When enabled, the SDA will show a flashing reminder below the sensor reading when a calibration adjustment is due (**Figure 43**). The reminder is displayed when the time since the last full high and low calibration adjustment was performed exceeds the reminder period specified when the feature is enabled. If the feature is disabled, no reminder will be displayed.

A calibration adjustment reminder will only be cleared once both a high and low calibration adjustment have been performed. Both adjustments should be performed with as little time between as possible. If not performed together, the calibration adjustment reminder will be shown based on the time of the earlier of the two adjustments.

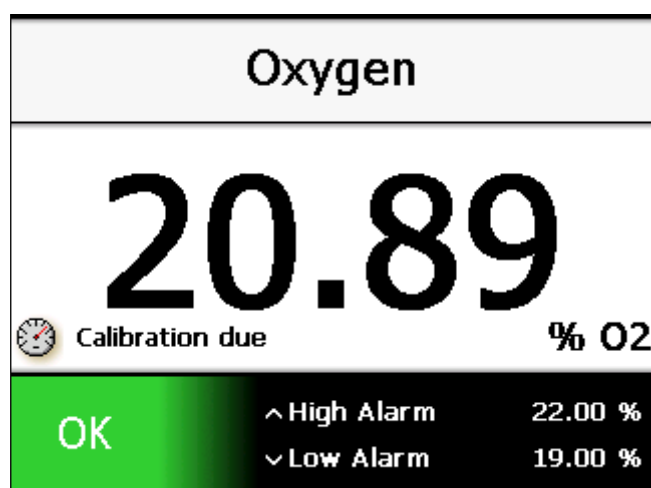

Figure 43 A calibration adjustment reminder

5.4.12 Menu

The device main menu can be accessed from the main screen by pressing the set button. The sensor reading shall remain in screen whilst the menu is display as show in **Figure 44**.

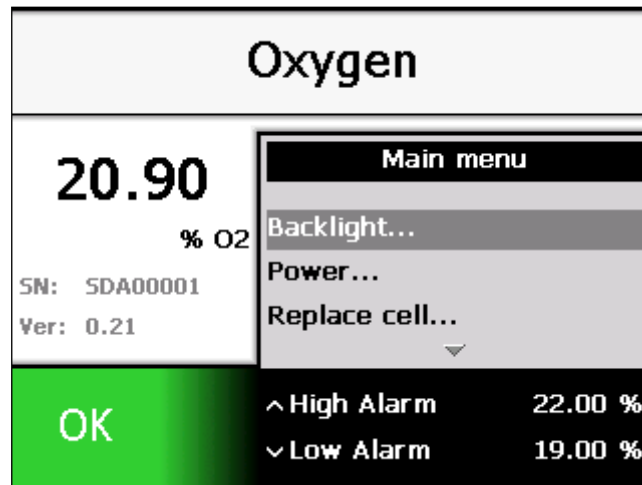

Figure 44 The main menu

The highlighted menu option can be changed by rotating the adjustment knob. Clockwise moves the cursor downwards and anti-clockwise moves it upwards. An arrow at the top or bottom of a menu indicates that there are more menu options above or below those currently shown.

To select a menu item, highlight it and press the set button. Depending on the menu item selected, the selected action will be performed, or a sub-menu will be displayed. **Figure 44** shows the main menu with the backlight menu item highlighted. Pressing set displays the backlight sub-menu as shown in **Figure 45** which shows that a backlight value of 40% has been selected. Pressing the set button will set the display backlight to 40%. The backlight menu will remain on-screen and can be closed by selecting exit or by pressing the mute button.

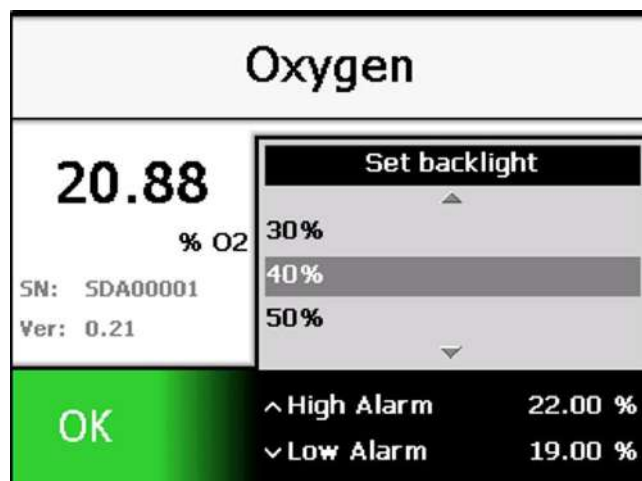

Figure 45 The backlight sub-menu

Selecting the back option from a sub-menu will return to the previous menu level. The mute button can be pressed at any time whilst using the menu to return to the main screen.

5.5 Adjusting the backlight

The brightness of the SDA display can be changed to suit the lighting conditions of its location by adjusting the backlight intensity. To adjust the backlight level, enter the main menu and select 'Backlight'. Next select the desired backlight intensity level (10-100%) from the menu.

NOTE:

DUE TO THE NATURE OF THE DISPLAY TECHNOLOGY, THE MAXIMUM INTENSITY OF THE DISPLAY WILL SLIGHTLY DEGRADE OVER THE LIFESPAN OF THE PRODUCT. FOR NEW SYSTEMS IT IS RECOMMENDED THAT THE BACKLIGHT IS SET TO AN INITIAL INTENSITY LEVEL OF 60% OR LESS TO MAXIMISE THE LIFESPAN OF THE DISPLAY.

5.6 Viewing device information

To view a range of information about an SDA including serial number, enabled options and attached peripherals access the main menu and select the 'Information' option. This will display the device information screen (**Figure 46**). To close the information screen and return to the main screen, press the mute button.

Information		Information	
Version:	2.0	Version:	2.0
Serial no:	SDA-00365	Serial no:	SDA-00123
Date:	2012-12-02	Date:	2012-11-30
Logging:	Yes	Logging:	Yes
Outputs:	No	Outputs:	No
Alarm Settings		Alarm Settings	
Latching:	No	Latching:	No
Repeating:	No	Repeating:	No
		Alarms	
OK	^ High Alarm	25.00 %	
	v Low Alarm	18.50 %	
		Alarms	
OK	^	30.0 °C	^ 75 %
	v	20.0 °C	v 25 %

Figure 46 The device information screen (single and dual sensor systems)

5.7 Data-logging

If the data-logging feature is enabled on an SDA then it will maintain a log of system and sensor data whenever the device is powered up. Data is logged every 10 seconds and includes the system status, average, minimum and maximum readings for the 10 second period. An SDA operates a 90-day rolling log. Once 90 days' worth of data is collected, the oldest day's data will be deleted so only the most recent 90 days are recorded.

Data can be downloaded into daily log files in .CSV (comma-separated values) format for easy import into popular spreadsheet applications. For instructions on downloading data-log files see section 6.4. An example of a typical data log file is shown below.

Date	Time	Status	Units	CO₂ Average	CO₂ Max	CO₂ Min
28/02/2011	14:34:10	OK	ppm	397	399	395
28/02/2011	14:34:20	OK	ppm	398	400	398
28/02/2011	14:34:30	OK	ppm	401	402	400
28/02/2011	14:34:40	Fault	ppm			

5.8 Changing network parameters

From the main menu select the Network menu, then the Parameters sub menu, here the user can change the IP address of the monitor so that they can connect to their own network.



Using the encoder to change the values in each parameter, use the SET button to toggle through each parameter and edit, use the SET button to move through until Save is reached, use the encoder to change to Yes and then press the Mute button to confirm. The system will then reboot with the new IP address.

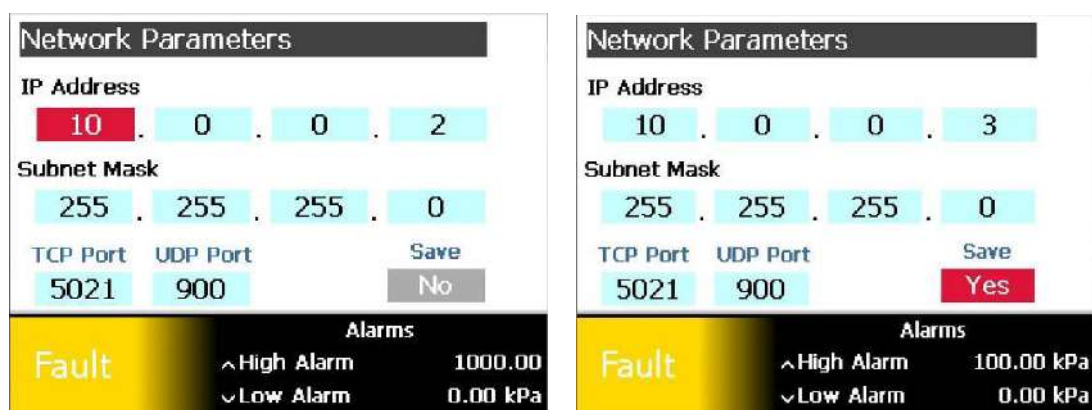

5.9 Serial data output

Under normal operation, without an output module attached to the device (see section 5.10), an SDA will continuously output information about the current system status and sensor reading via the data port. The data is output via an RS485 serial stream in a readable ASCII format. For details of how to make a correct physical connection to the data port in order to collect the output data see section 4.3. The set-up parameters for an external system to correctly receive the output data are as follows.

BAUD rate:	9600
Date bits:	8
Parity:	None
Stop bits:	1
Flow control:	None

The format of the data output stream is a comma-delimited ASCII character string terminated by a carriage return character (0Dh) and a line feed character (0Ah). A terminated character string is output once per second. This stream is designed to be read and displayed by a terminal program, written to a text file for data-logging or captured by a third-party software to be interpreted and used in external applications. The comma delimited nature of the string allows it to be easily logged to a .CSV file for simple import into popular spreadsheet applications.

The content of each terminated string consists of the following:

- Date (YYYY-MM-DD)
- Time (HH:MM:SS)
- System status (OK or Fault)
- The units type of the sensor data to follow (% , ppm, etc.)
- The average sensor reading
- The minimum sensor reading since the last data string
- The maximum sensor reading since the last data string
- The instrument serial number

The following shows two examples of typical data strings, the number at the end of the string is the instrument serial number. The second shows a fault condition in which case the sensor readings are not shown.

```
2011-03-23,09:49:31,OK,ppm,625,625,625,, ,SDA01854↵  
2011-03-24,10:36:12,Fault,% , ,SDA01854↵
```

**NOTE:**

FOR A DUAL SENSOR DEVICE, THE OUTPUT MESSAGE IS EXTENDED WITH THE SECOND SENSOR'S DATA APPENDED. FOR EXAMPLE:

```
2011-03-23,09:49:31,OK,C,25.4,25.3,25.5,%,35,35,36, SDA2003↵  
2011-03-24,10:36:12,Fault,% , , SDA2003↵
```

5.10 Output module

To expand a single sensor SDA to provide relays and an analogue output, an optional Analox output module can be connected to the system.



NOTE:

THE OUTPUT MODULE CAN ONLY PROVIDE ANALOGUE AND RELAY OUTPUT FOR ONE SENSOR. IF ATTACHED TO A DUAL SENSOR UNIT, THE OUTPUT MODULE WILL PROVIDE OUTPUTS FOR THE FIRST SENSOR ONLY.

5.10.1 Connecting an output module

To connect an output module, the SDA should first be disconnected from the DC power supply. The output module communication cable should be connected to the Data port on the rear of the SDA (see section 5.9 for instructions on connecting to the Data port).

When power is applied to an SDA with an output module is connected it will automatically recognise that the module is connected. A few seconds after the main screen is shown on start-up, the output module will begin to reflect the sensor reading and alarm status. The connection status of an output module can be viewed on the information screen (see section 5.6).

5.10.2 Relays

An output module provides two relays. Each relay is mapped to one of the SDA alarms. Relay 1 is mapped to the lower alarm and Relay 2 is mapped to the higher alarm (**Figure 47**). If an alarm is not active, then its corresponding relay will be in the energised state (connection between Com and NO is made). If an alarm is triggered, then the corresponding relay will switch to the de-energised state (connection between Com and NC is made).

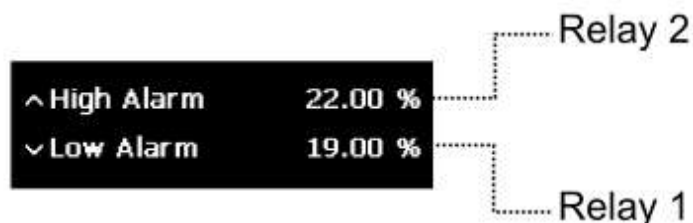

Figure 47 Alarm relay mapping

If any system fault is detected, then both relays will switch to their de-energised alarm states to correspond with the fault alarm that is raised for a system fault.

5.10.3 Analogue output

The output module's analogue output is used to reflect the SDA's sensor reading. The nominal range of the output current is 4-20mA (see section 4.3 for connection details). This range corresponds to the range of the sensor attached. For example, for a 5000ppm ranged carbon dioxide sensor, 0ppm carbon dioxide measured will correspond to an output of 4mA and 5000ppm carbon dioxide measured will correspond to an output of 20mA.

If any system fault is detected, then the analogue output will output a current beyond the 20mA upper range of the sensor range (approx. 22mA) to correspond with the fault alarm that is raised for a system fault.

5.10.4 Communication & power faults

If a faulty or intermittent connection exists between an SDA and an output module whilst the output module remains powered, then the output module will assume a fault and set its relay and analogue output to their fault states as described above.

If power to an output module is lost, the relays will return to a de-energised alarm state and the analogue output will output 0mA.

5.11 Power modes

When connected to a DC power supply the SDA device will start up automatically and remain powered whilst connected.

5.11.1 Sleep mode

An SDA can be switched into a sleep mode which will allow the device to remain powered but silent. No alarms will be raised whilst in sleep mode. Also, in sleep mode, the display will be powered down and any data-logging will be paused. The unit and sensors will remain powered to allow for a quick wake-up from sleep mode. All buttons except for the set button will be disabled whilst in sleep mode.

To switch the device into sleep mode, access the main menu (see 5.4.12) and select "Power..." followed by "Sleep".

To wake the device from sleep mode, press the set button. The display will be switched on, monitoring for alarms will begin again and data-logging will re-commence.

5.11.2 Restarting

To prompt a full reboot of an SDA device, access the main menu (see 5.4.12) and select "Power..." followed by the "Restart..." option. This option will ask for confirmation. Selecting yes will force the system to restart.

5.12 Cell replacement reminder

For SDA sensors which use electrochemical technology, such as the MEC sensor, the electrochemical cell part of the sensor needs to be periodically replaced as the cell depletes. To aid with the timely replacement of cells the SDA provides a cell replacement reminder feature. This feature is only available for sensors which require cell replacement (e.g. oxygen). Sensors which do not use electrochemical technology (e.g. carbon dioxide) do not use this feature.

The cell replacement reminder feature can be enabled or disabled using the SDA software as described in section 6.3.2.

If the cell replacement feature is enabled and the sensor is an electrochemical type, the SDA will show an onscreen warning when the cell is due to be replaced as shown in **Figure 48**. The cell replacement reminder is shown once the number of days that have elapsed since the cell was last replaced exceeds the cell replacement reminder period defined using the SDA software.

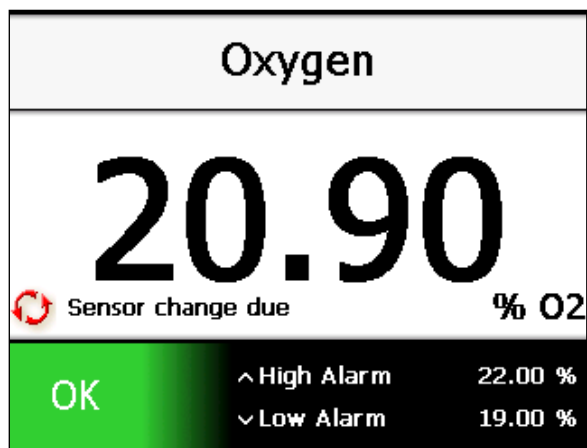

Figure 48 **Sensor change reminder**

The cell reminder period can be adjusted using the SDA software to suit expected sensor usage. For example, some oxygen cells are expected to last for 2 years in atmospheric levels of oxygen. However, oxygen cells will deplete faster if they are exposed to higher levels of oxygen, so if the sensor is expected to be exposed to higher levels of oxygen over its service, then the reminder period can be shortened to serve as a reminder that the cell is expected to age more quickly.



NOTE: **THE CELL REPLACEMENT FEATURE IS INTENDED TO BE USED ONLY AS A GUIDE AND CANNOT ACCURATELY DETERMINE THE LIFESPAN OF A CELL. IF A SENSOR BECOMES DIFFICULT TO CALIBRATE AFTER A PERIOD OF TIME IN SERVICE, THEN IT SHOULD BE REPLACED REGARDLESS OF THE REMINDER STATUS.**

5.12.1 Replacing a cell and resetting the reminder

Once an electrochemical cell has been replaced (see section 8.1), the cell replacement reminder will continue to be shown and needs to be manually reset. For SDAs which use electrochemical sensors, this warning can be reset from the SDA menu. To do this open the main menu and select 'Replace cell...'. Select the sensor to reset and confirm the action. Upon confirmation, this will store the current date as the date on which the cell was last replaced.

6 Configuration

In order to set options on an SDA, the SDA software is provided to allow a device to be configured using a USB connection. The SDA software is designed to run on Microsoft Windows®.

6.1 Software installation



NOTE: BEFORE CONNECTING AN SDA TO A COMPUTER, THE APPROPRIATE SOFTWARE SHOULD BE INSTALLED.



NOTE: DEVICES WITH A SERIAL NUMBER BELOW 06000 WILL REQUIRE ADDITIONAL SETUP AS DETAILED IN DOCUMENT [XKO-845 SDA PC TOOL \(V2.3\) INSTALLATION GUIDE](#) BEFORE INSTALLING THE PC TOOL. THIS CAN BE FOUND ON THE ANALOX WEBSITE, THE 'YELLOW' DRIVER IS REQUIRED TO BE INSTALLED FOR THESE DEVICES TO CONNECT TO THE PC TOOL CORRECTLY.

6.1.1 Software requirements

The SDA software is designed to run on Microsoft Windows® and has the following prerequisites:

- Microsoft Windows XP®, Windows Vista®, Windows 7®, Windows 8.1® or Windows 10®
- Microsoft .NET Framework 3.5 SP1 or later
- Microsoft ActiveSync® 4.5 or later (Windows XP® only)
- Microsoft Windows Mobile Device Centre 6.1 or later (Windows Vista®, Windows 7®, Windows 8.1 & Windows 10® only)

6.1.2 Windows® XP Installation

To install the SDA software on Windows XP®, perform the following steps.

- 1] Download the software from the Analox website using the QR code or copy and paste the address.



https://drive.google.com/file/d/0B_7yOP8oV_zLZ3M3ejVnMFFYUVU/view?usp=sharing&resourcekey=0-4m4WNRBRJSIDNCuAbirfjQ

- 2] Unzip the files into a new folder names SDA software on your desktop.
- 3] Unplug all unnecessary USB devices from the computer.
- 4] If not already installed, install Microsoft ActiveSync® 4.5 or later. This software is available as a free download from the Microsoft Download Centre
- 5] Connect the SDA to the computer using the USB cable and switch on the SDA.

- 6] The device should automatically connect to ActiveSync and may pop up the ActiveSync "Synchronization Setup Wizard" window. This wizard can be cancelled.
- 7] From the SDA software folder, run the installer file called 'Setup'.
- 8] The installer will check that the .NET Framework is installed. If not, you will be prompted to allow the framework to be installed. It is recommended that you allow this. Alternatively, the .NET Framework is available as a free download from the Microsoft Download Centre
- 9] Once the installer is satisfied that the .NET Framework is installed, the SDA installer wizard will be displayed. Follow the on-screen instructions to install the SDA software.

6.1.3 Windows® Vista & Windows® 7 Installation

To install the SDA software on Windows® Vista or Windows7®, perform the following steps.

- 1] Download the software from the Analox website using the QR code or copy and paste the address.



https://drive.google.com/file/d/0B_7yOP8oV_zLZ3M3ejVnMFFYUVU/view?usp=sharing&resourcekey=0-4m4WNrBRJSIDNCuAbirfjQ

- 2] Unzip the files into a new folder names SDA software on your desktop.
- 3] Unplug all unnecessary USB devices from the computer.
- 4] Connect the SDA to your computer via USB. Wait a few moments for drivers to automatically install.
- 5] If Microsoft Windows Mobile Device Centre is installed on your computer, it will open at this point. Otherwise WMDC will now be automatically installed.
- 6] Connect the SDA to the computer using the USB cable and switch on the SDA.
- 7] The Windows Mobile Device Centre main window may pop up. This window can be closed. Accept the Windows Mobile Device Centre user agreement if prompted.
- 8] From the SDA software folder, run the installer file called 'Setup'.
- 9] The SDA installer wizard will be displayed. Follow the on-screen instructions to install the SDA software.

6.1.4 Windows® 8 Installation

6.1.4.1 Installing Windows Mobile Device Centre

To install the SDA software on Windows® 8, perform the following steps.

- 1] Unplug all unnecessary USB devices from the computer keeping the SDA plugged in.
- 2] You will need .NET Framework 3.5 & Windows Mobile Device Centre installed on your computer. If you already have these then jump ahead to 6.1.4.2. Otherwise continue with these steps to install both.
- 3] Click the start button and start typing "programs and features." Windows will present apps with that name, as shown below. Click on "Programs and Features."
- 4] In the dialog box that appears, click "Turn Windows features on or off."

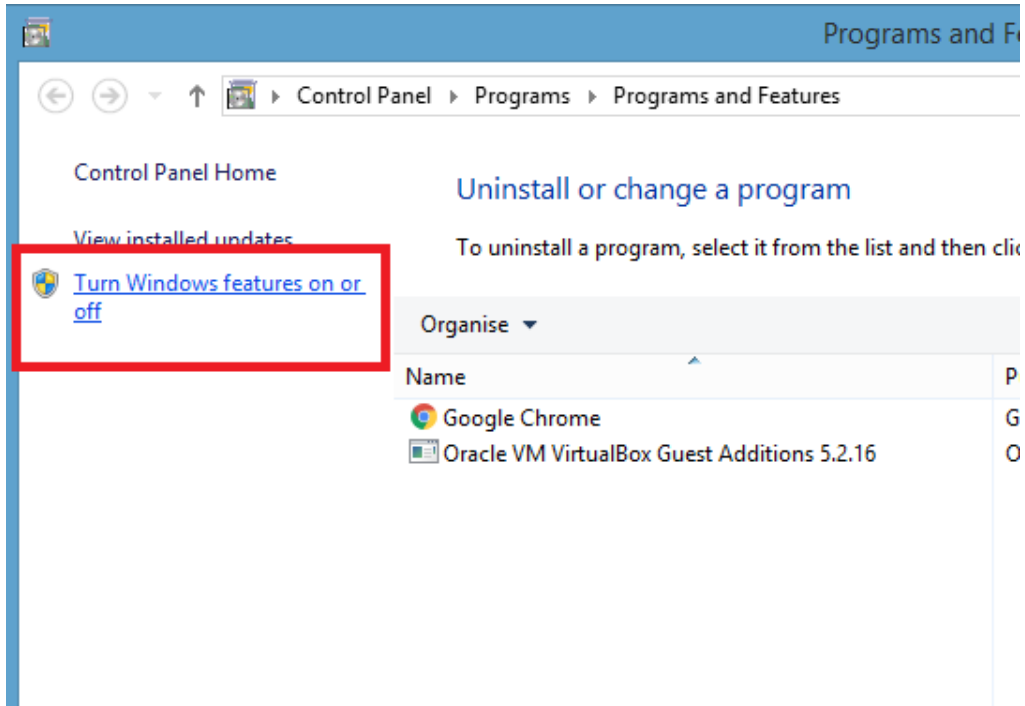

- 5] Check the box next to .NET Framework 3.5 (includes .NET 2.0 and 3.0). If windows asks for permission to download the feature, click to allow this.

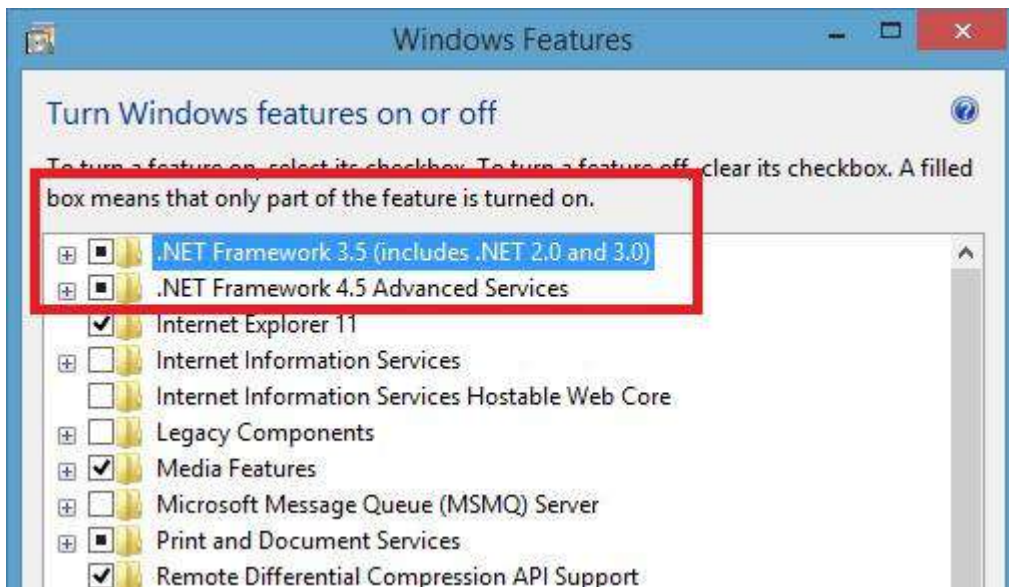

- 6] Connect the SDA to your computer via USB. Wait a few moments for drivers to automatically install. Windows will then automatically install Windows Mobile Device Centre and connect to your SDA.

6.1.4.2 Installing the software

- 1] Download the software from the Analox website using the QR code or copy and paste the address.



https://drive.google.com/file/d/0B_7yOP8oV_zLZ3M3ejVnMFFYUVU/view?usp=sharing&resourcekey=0-4m4WnrBRJSIDNCuAbirfjQ

- 2] Unzip the files into a new folder names SDA software on your desktop.
- 3] If installing from the SDA software CD, insert the disc into the CD drive.
- 4] Ensure that the SDA is connected to the computer using the USB cable.
- 5] The Windows Mobile Device Centre main window may pop up. This window can be closed. Accept the Windows Mobile Device Centre user agreement if prompted.
- 6] From the SDA software folder, run the installer file called 'Setup'.
- 7] The SDA installer wizard will be displayed. Follow the on-screen instructions to install the SDA software.

6.1.5 Windows® 10 Installation

- 1] Download the software from the Analox website using the QR code or copy and paste the address.



https://drive.google.com/file/d/0B_7yOP8oV_zLZ3M3ejVnMFFYUVU/view?usp=sharing&resourcekey=0-4m4WNrBRJSIDNCuAbirfjQ

- 2] Unzip the files into a new folder names SDA software on your desktop.
- 3] Ensure that you have the .NET framework Version 2.0 installed. This can be obtained from the Microsoft Website or via google.
- 4] Run the installer from the SDA software folder (You will need administrator privileges to do this)
- 5] Connect the SDA to your PC by USB cable. If Windows Mobile Device Centre (WMDC) is not already installed on your PC, then Windows 10 will ask your permission to install it. Click 'OK' when prompted and WMDC will automatically be installed.

6.1.6 Running the software

To run the SDA software, select the program from the Windows® start menu, Analox folder. When the software runs without a device connected, the window shown in **Figure 49** will be displayed.



Figure 49 SDA software without device connected

6.2 Making a connection



NOTE: THE SDA SOFTWARE USES MICROSOFT ACTIVESYNC® TO COMMUNICATE WITH AN SDA. BEFORE CONNECTING TO AN SDA, ENSURE THAT ANY OTHER WINDOWS MOBILE DEVICES OR DEVICES WHICH MAKE USE OF ACTIVESYNC® ARE DISCONNECTED FROM THE COMPUTER.

Prior to connecting the SDA to the PC tool, the SDA is required to be put to sleep. To do this, press the Set button to view the main menu, then select the Power option using the rotary encoder, then select Sleep from the Power menu, the screen will go blank, and you can then connect the SDA to the PC tool.

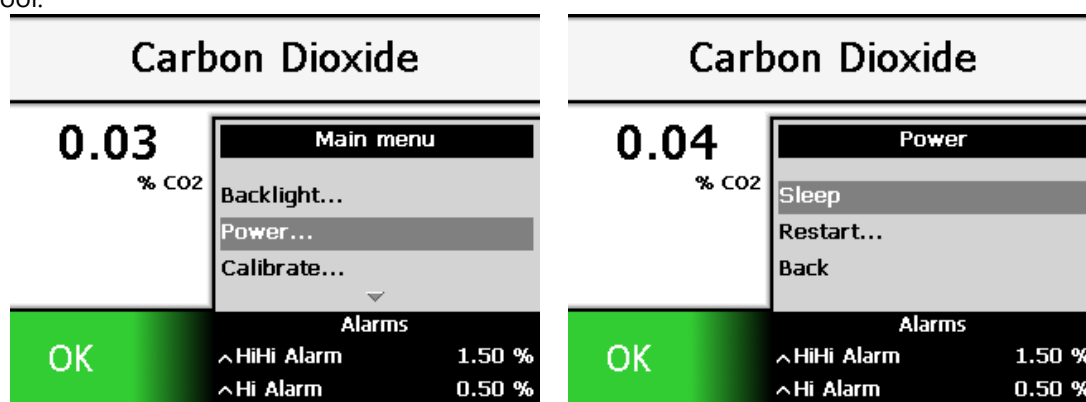

Figure 50 Sleep mode menu

Always connect only one SDA to the computer at a time. To connect an SDA to the computer, connect one end of the USB cable provided to the SDA PC port on the rear panel and connect the other end of the cable to a free USB port on the computer. Power the SDA device and allow it to start up.

Once connected and powered, Windows® should detect the device and display an information bubble confirming the connection. On the first time connecting an SDA to the computer, message bubbles may be shown explaining that device drivers are being installed. This should take a few moments.

When the device connects, on Window XP® systems, the ActiveSync window will pop up. This window should be closed. On Window 7® systems, the Windows Mobile Device Centre window will be shown. This window should be closed.

If not already open, run the SDA software. The SDA software will recognise the device and read the current settings form the device. Once fully connected the window shown in **Figure 51** will be displayed.

6.2.1 Connection troubleshooting

If the SDA fails to connect, try the following:

- 1] Disconnect the SDA from the computer
- 2] Go to the folder C:\Program Files\Microsoft ActiveSync\Drivers and look for the file called wceusbsh.sys
- 3] Select this file, copy it and paste it into the following folder C:\Windows\System32\drivers
- 4] Restart the computer
- 5] When restarted, connect the powered-up SDA to the computer
- 6] Follow the user manual instructions for installation of the device drivers. This time the installer should locate the correct file and install correctly

6.2.2 Disconnecting

To disconnect an SDA from the computer, first wait until all settings have been saved correctly and that any file downloads have completed then remove the USB cable from the computer.



NOTE:

ONCE FINISHED, TO BRING THE SDA OUT OF SLEEP MODE, PRESS THE SET BUTTON ON THE FRONT PANEL.

6.3 Changing options

On connection to an SDA, a copy of all of the device's options is created in the SDA software. The options are presented over a set of tabs. To view the options tabs, click the 'Options' button. Using these tabs the options can be viewed and modified as required. No changes are made to the device's options until the changes are applied to the device. To apply any changes made click the 'Apply Changes' button (shown in **Figure 51**), this will upload the new options to the device. The SDA will confirm that the options have been saved by playing a confirmation sound.

Any changes made to options can be discarded as long as they have not yet been applied to the device. To re-download the current device settings from an SDA, click the 'Read Options' button (shown in Figure 51 SDA software with device **connected showing general options**

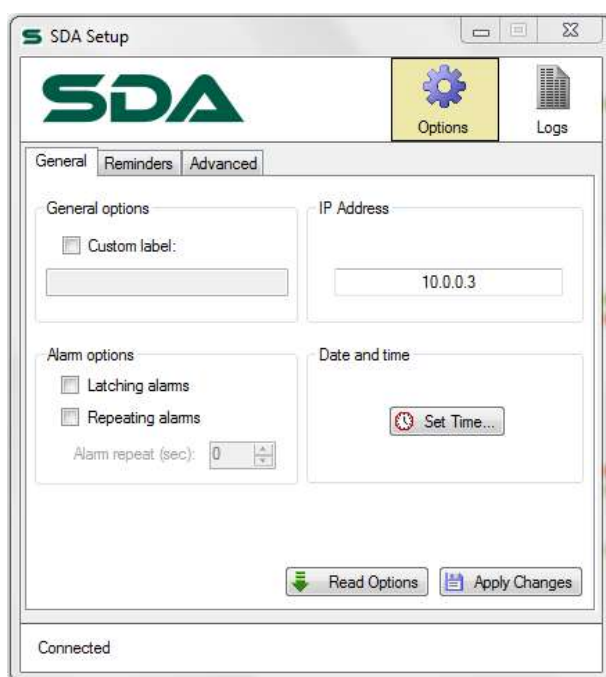

Figure 51 SDA software with device connected showing general options

6.3.1 General options

The general device options are displayed by clicking on the 'General' tab. **Figure 51** shows the general options.

6.3.1.1 Custom label

A custom label can be enabled by checking the 'Custom label' checkbox. If enabled, a custom text label can be added to the text box. This will instruct the SDA to display a custom text label on its main screen as described in section 5.2.3.

If the custom label checkbox is unchecked, then the device will show a default label which will be the configuration type (e.g. 'Oxygen').

6.3.1.2 Latching alarms

The latching alarms checkbox enables or disables latching alarms as described in section 5.4.3.

6.3.1.3 Repeating alarms

The repeating alarms checkbox enables or disables the alarm reminder feature as described in section 5.4.5. If the repeating alarms feature is enabled, an alarm repeat interval should be set. This defines the time in seconds before a muted alarm will be re-triggered. Setting this value to zero will automatically disable the feature.

6.3.1.4 Date and time

The 'Set Time...' button can be used to set the date and time on the device as described in section 6.5.

6.3.1.5 Setting IP address

The IP address can also be changed from within the PC Tool as well as on the instrument itself. Under the General tab, in the IP Address box, enter the new IP address of the instrument, then click Apply Changes.

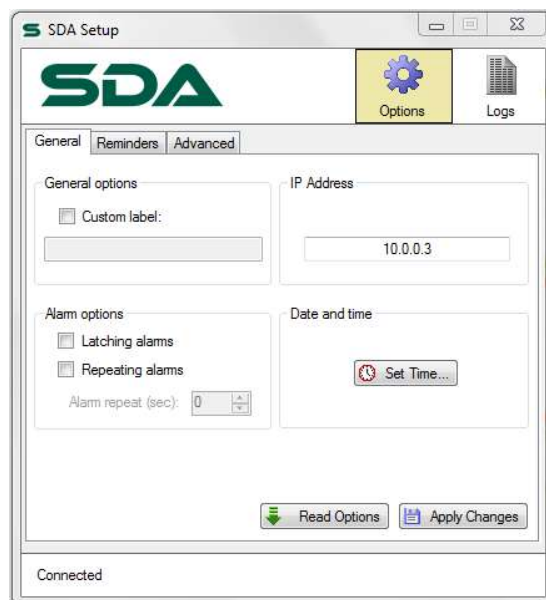

NOTE:

ANY CHANGES MADE TO THE GENERAL OPTIONS WILL NOT COME INTO EFFECT ON AN SDA DEVICE UNTIL THE 'APPLY

CHANGES' BUTTON HAS BEEN CLICKED WITH THE EXCEPTION OF SETTING THE DATE AND TIME (SEE SECTION 6.5).

6.3.2 Reminder options

The reminders options are displayed by clicking on the 'Reminders' tab. **Figure 52** shows the reminders options.

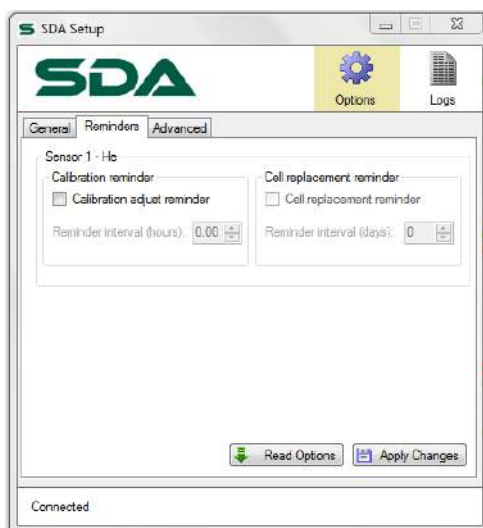

Figure 52 **Reminder options**

6.3.2.1 Calibration reminder

The 'Calibration adjust reminder' checkbox enables or disables the calibration adjust reminder as described in section 5.4.11. If the calibration adjust reminder feature is enabled, a reminder interval should be set. This defines the time in hours since the last full calibration adjust before a calibration adjust reminder will be displayed on the SDA. Setting this value to zero will automatically disable the feature.

6.3.2.2 Cell replacement reminder

The 'Cell replacement reminder' checkbox enables or disables the cell replacement reminder as described in section 5.12. If the cell replacement reminder feature is enabled, a reminder interval should be set. This defines the time in days since the cell was last replaced before a cell replacement reminder will be displayed on the SDA. Setting this value to zero will automatically disable the feature.



NOTE:

FOR SENSORS WHERE THERE IS NO CELL TO REPLACE SUCH AS CARBON DIOXIDE, THIS FEATURE WILL NOT BE AVAILABLE AND CELL REPLACEMENT REMINDERS WILL NOT BE SHOWN ON THE SDA. THIS FEATURE APPLIES ONLY TO SENSORS WITH ELECTROCHEMICAL CELLS WHICH DEplete OVER TIME.

6.4 Downloading data logs

If an SDA is enabled with internal data-logging then the data stored on the device can be downloaded using the SDA software. To view the data-log management controls, click the 'Logs' button (**Figure 53**). If data-logging is enabled on the device, a list of the data-log files available on the device will be shown. This list will be empty if data-logging is not enabled. The data-log files are stored by date. Each date's file contains all of the data logged whilst the device was running during a particular day. This list can be refreshed by pressing the 'Refresh' button.

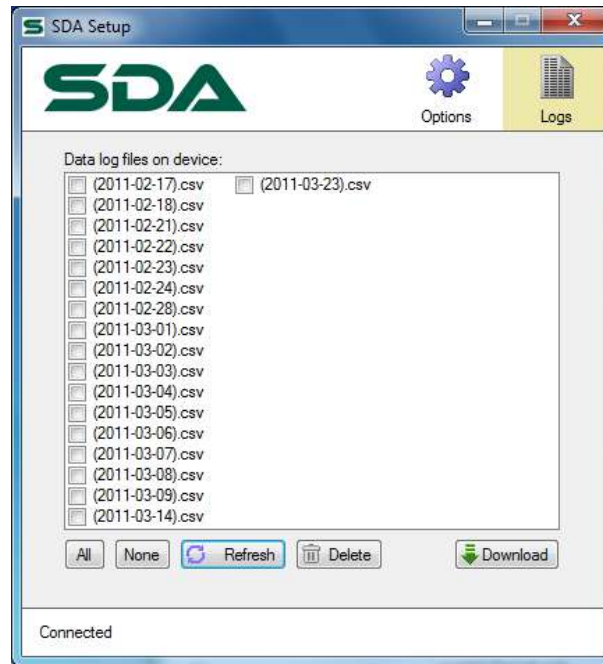

Figure 53 *The data logs available on a connected SDA*

Data-log files can be downloaded individually or in batches. To select the files that are to be downloaded, click on the checkbox next to each of the files of interest. The 'All' and 'None' buttons can be used to select or deselect all of the files respectively. Once a selection has been made, the log file download can be started by clicking the 'Download' button. **Figure 54** shows a selection of files being downloaded.

**NOTE:**

THE TIME TAKEN TO DOWNLOAD DATA LOGS WILL VARY DEPENDING ON THE NUMBER OF LOG FILES SELECTED AND THE AMOUNT OF LOG DATA INSIDE EACH FILE. THIS PROCESS MAY TAKE SEVERAL MINUTES. IT SHOULD ALSO BE NOTED THAT DOWNLOADING A FULL DATA LOG MAY DOWNLOAD UP TO 50MB OF LOG DATA. PLEASE ENSURE THAT THERE IS ENOUGH STORAGE SPACE ON THE TARGET DISK BEFORE BEGINNING A DOWNLOAD.

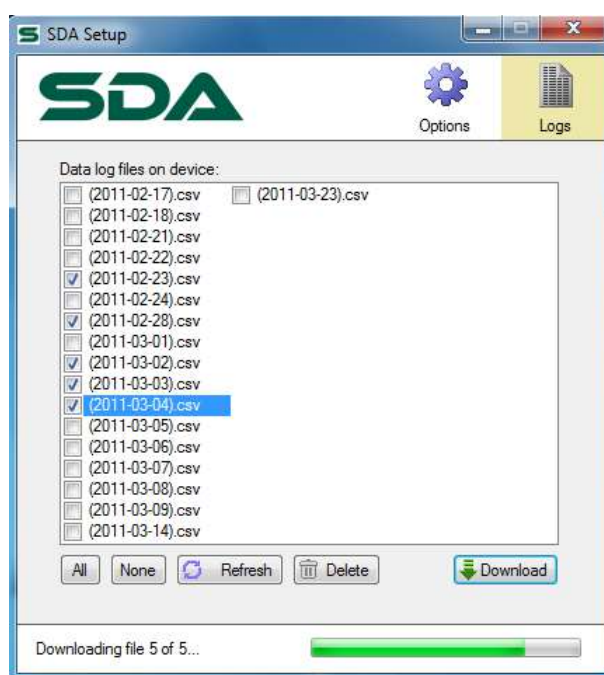

Figure 54 Downloading data logs from an SDA

Although the internal data-logging operates a rolling log with automatic clean-up of older data, the data-logs on the device can be managed manually using the SDA software. To delete unwanted files from a device, select the files for deletion and click the 'Delete' button.

6.5 Setting the time

The SDA's internal date and time is used for data-logging and for issuing various reminders. The internal clock can be set to the appropriate date and time using the SDA software. With an SDA connected to the SDA software, select the 'General' tab. Click the 'Set Time...' button. This we display the window shown in **Figure 55**. The default time shown will be the system date and time of the computer running the software. This date and time can be changed if required. To set the date & time on the device click OK. The SDA will play a sound to acknowledge that the date and time have been set successfully.

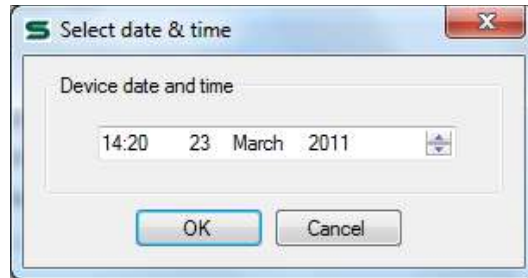

Figure 55 *Setting the date and time on an SDA*

7 Troubleshooting

7.1 Fault conditions

An instrument constantly monitors itself for fault conditions. Any fault conditions that are identified will trigger a fault alarm. When a fault alarm is raised, the horn will sound immediately. Faults will be indicated on the display by flashing the system status indicator in yellow as shown in **Figure 56**. Fault alarms can be muted in the same way as standard alarms by pressing the mute button. When pressed, the horn will deactivate and the system status indicator will be shown as solid yellow to indicate that the fault has been acknowledged.

All fault alarms are latching so if an intermittent fault is identified and subsequently cleared, the alarm will continue to be displayed and sounded until the mute button is pressed to acknowledge the fault.

Information about the fault condition identified is displayed below the sensor reading as shown in **Figure 56** in which a sensor communication fault is shown. In cases where a fault prevents a valid reading from being obtained from a sensor then the reading will not be shown on the display and will instead be replaced by '---'.

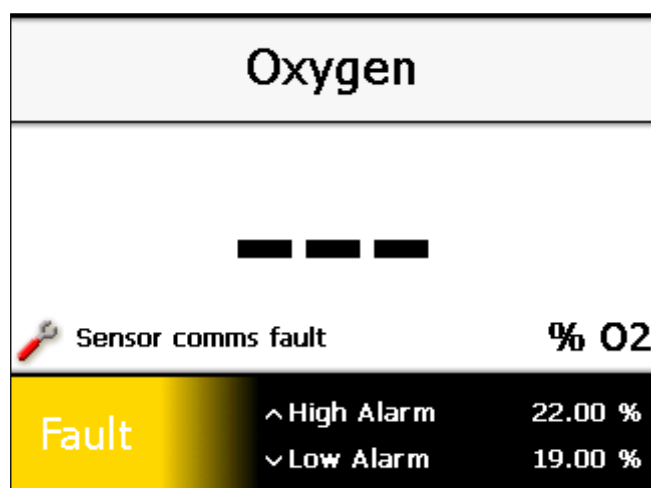

Figure 56 A system showing a fault condition

7.2 Fault logging

All instances of fault conditions that are identified will be logged to the instrument's diagnostics log. Both the point at which the fault is identified and the point at which the fault is cleared will be logged. The diagnostics log can be downloaded using the SDA software. To download the log, connect to the device as described in section 6. Access the 'Advanced' tab and click 'Download diagnostics log...'. This will give the option to specify a save location for the log file.

7.3 Problems and actions

Problem	Action
'Sensor comms fault' shown on the display.	A serial communication link has been lost with the sensor. Check that the sensor connector is firmly connected to the sensor port at the rear of the unit. Check that all screw terminal connections and cable crimps are securely fitted to the sensor connector and that the wires are connected to the correct terminals. Check that the cable that connects to the sensor is not damaged.
'Sensor range fault' shown on the display	The sensor is detecting a condition outside of its effective range. Check that the sensor is not being exposed to conditions outside of its effective range. Re-calibrate the unit. Restart the SDA device. If the problem persists, please contact your supplier.
'Sensor fault' shown on the display	The sensor has detected a fault in its operation. Restart the SDA unit. If the problem persists, please contact your supplier.
'Sensor fatal error' shown on the display	The sensor has detected a fault in its operation. Restart the SDA unit. If the problem persists, please contact your supplier.
'Net Flt: Bad Pressure'	Pressure reading obtained via the network is invalid
'Net Flt: No Pressure'	No pressure reading obtained on the network.
'Net Flt: Bad Oxygen'	Oxygen reading obtained via the network is invalid.
'Net Flt: No Oxygen'	No Oxygen reading obtained on the network.

7.4 Unhandled exceptions

If the SDA reports an unhandled exception as shown in **Figure 57**, the user should record the message displayed and report the incident to Analox by following the fault reporting procedure. The user should include the circumstances in which the unhandled exception occurred.



Figure 57 A system showing an unhandled exception

To return the SDA to normal function, press the Set button on the front panel, this will restart the SDA. Allow the SDA to finish its warm-up cycle.

8 Maintenance

8.1 Oxygen cell replacement

Replacement part number for the cell is: **9100-9212-9HM**

When a replacement cell is received check that the sensor has not leaked. The sensors are themselves sealed and do not under normal circumstances present a health hazard however if leakage of the electrolyte has occurred use rubber gloves and wear chemical splash goggles to handle and clean up. Rinse contaminated surfaces with water. If anybody comes into contact with the electrolyte, please refer to section 1.1 for safety and handling guidelines.

- 1] Ensure all electrical connections between the MEC and monitor equipment are disconnected.
- 2] Loosen the corner screws of the enclosure and remove the lid.

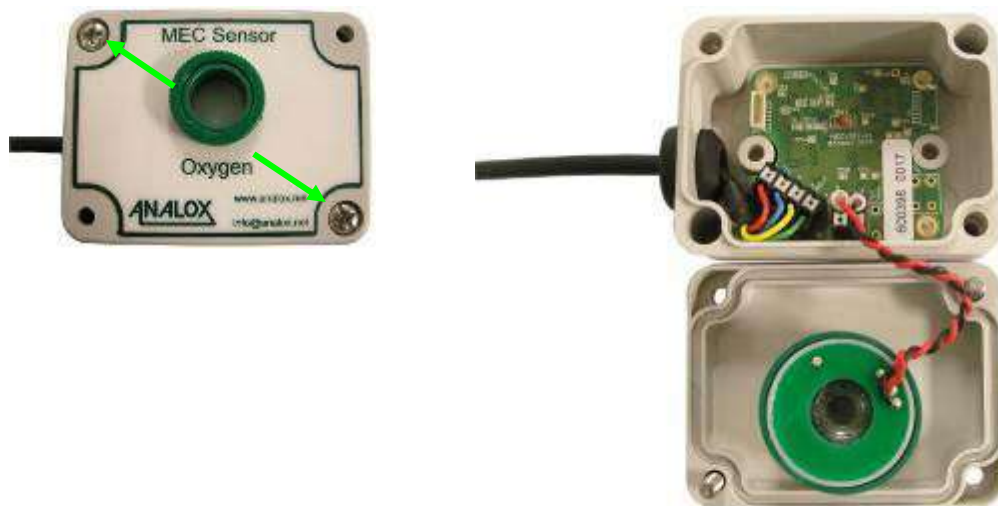

Figure 58 **Removing the MEC lid**

- 3] Using a terminal screwdriver push down the clamp release button to release the clamp and gently pull the cell wire from the clamp. Repeat this for both the red and black wires.



Figure 59 **Disconnecting the cell**

- 4] Unscrew the green lock ring from the chimney of the cell housing and remove from the enclosure lid.



Figure 60 **Removing the cell from the lid**

- 5] Fit the new cell in to the enclosure lid and secure in place using the lock ring.
- 6] Using a terminal screwdriver push down the clamp release button to release the clamp. Push the ferrule of the cell wire into the clamp and remove the screwdriver from the clamp release button. Gently pull on the wire to ensure that the wire is held by the clamp. Repeat this for both the red and black wires, taking note of the correct polarity as shown below.

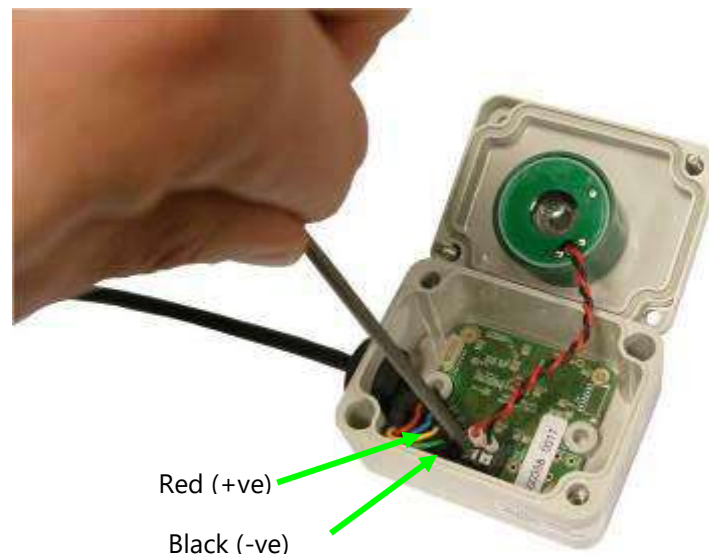

Figure 61 **Connecting a new cell**

- 7] Fit the enclosure lid and secure in place using the corner screws.
- 8] Following an oxygen cell replacement a full calibration MUST be performed, as described in section 5.4.8.
- 9] If the cell replacement reminder option is in use, then the reminder must be manually reset after replacing the cell, as described in section 5.12.1.

8.2 Carbon monoxide cell replacement

8.2.1 SDA CO

The part number for your sensor's replacement cell is: **9100-2030S**

When a replacement cell is received check that the cell has not leaked. The cells are themselves sealed and do not under normal circumstances present a health hazard however if leakage of the electrolyte has occurred use rubber gloves and wear chemical splash goggles to handle and clean up. Rinse contaminated surfaces with water. If contact is made with the electrolyte, please refer to section 1.1 for safety and handling guidelines.

- 1] Ensure all electrical connections between the MEC and monitor equipment are disconnected.
- 2] Use a flat blade screwdriver to pop out the cell holder from the sensor bulkhead fitting.

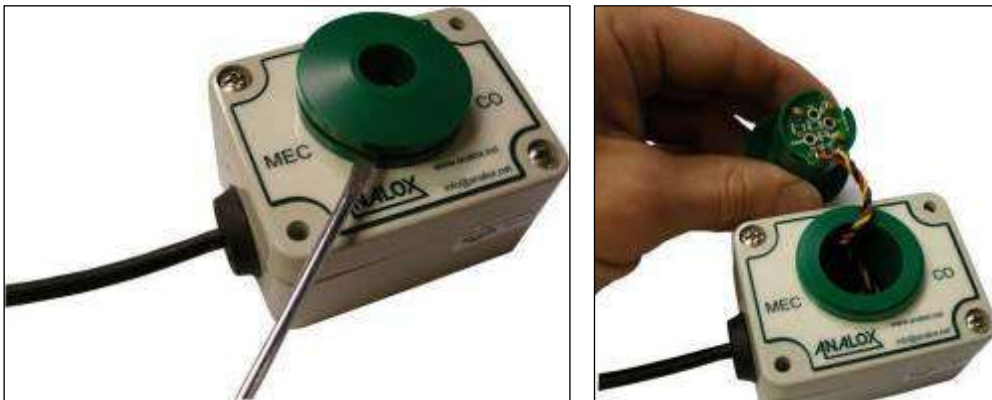

- 3] Rotate the cell PCB connector clockwise to release from the cell holder.

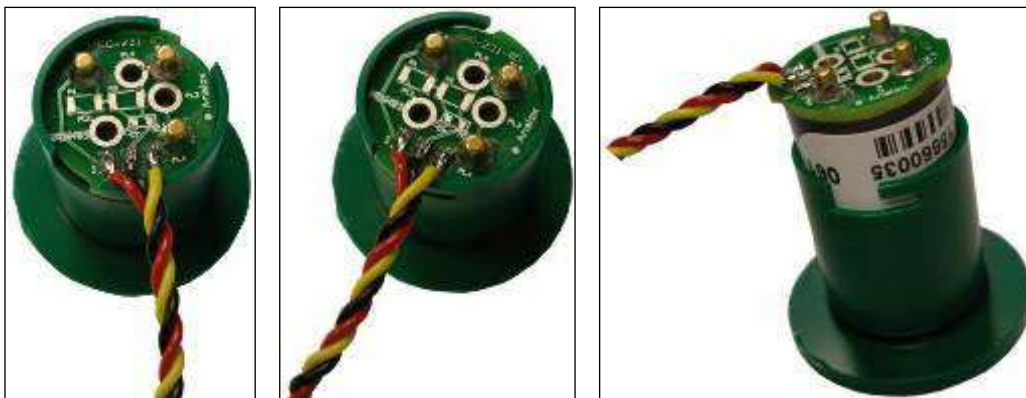

- 4] Disconnect the cell from the PCB connector.

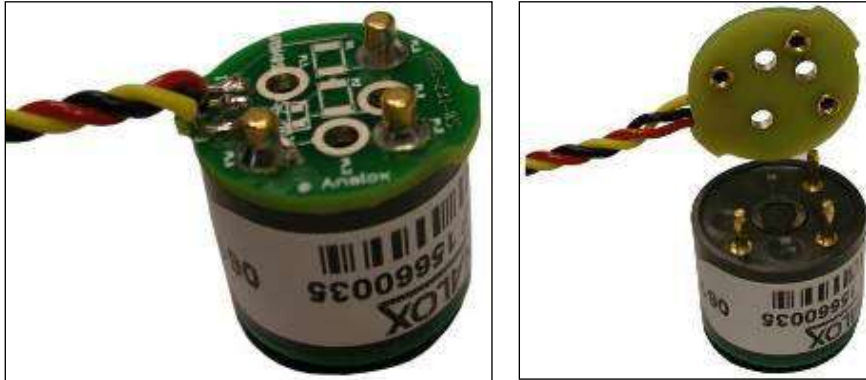

- 5] Connect the new cell to the PCB connector (Note that it will only connect in one orientation).

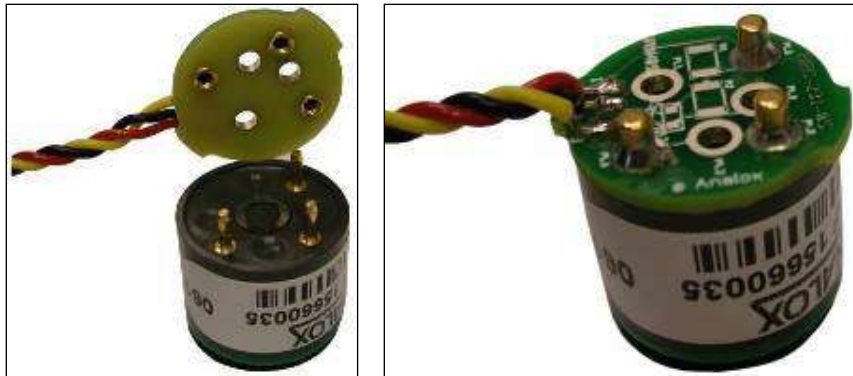

- 6] Fit the cell in to the housing and rotate anti-clockwise to lock in place.



- 7] Refit the cell holder into the sensor bulkhead.
- 8] Following a carbon monoxide cell replacement, a full calibration **MUST** be performed, as described in section 5.4.8.
- 9] If the cell replacement reminder option is in use, then the reminder must be manually reset after replacing the cell, as described in section 3.13.1.

8.2.2 SDA CO+

The part number for your sensor's replacement cell is: **CO-B4**

When a replacement cell is received check that the cell has not leaked. The cells are themselves sealed and do not under normal circumstances present a health hazard however if leakage of the electrolyte has occurred use rubber gloves and wear chemical splash goggles to handle and clean up. Rinse contaminated surfaces with water. If contact is made with the electrolyte, please refer to section 9.1 for safety and handling guidelines.

- 1] Ensure all electrical connections between the TEC and monitor equipment are disconnected.
- 2] Use a Pozi Pan screwdriver unscrew the two corner lid screws to remove the lid.

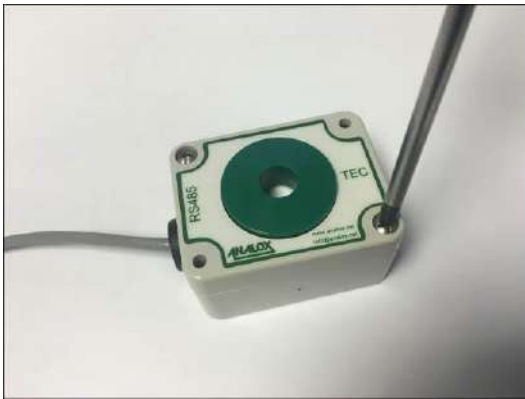

- 3] Pull the sensor from the PCB located in the bottom of the enclosure.

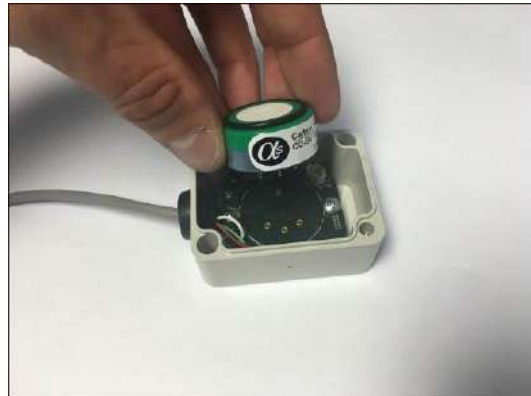
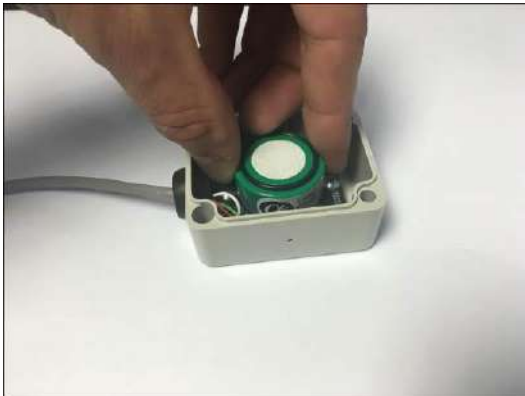

- 4] Take the new carbon monoxide cell and refit to the internal PCB (This can only be fitted one way).

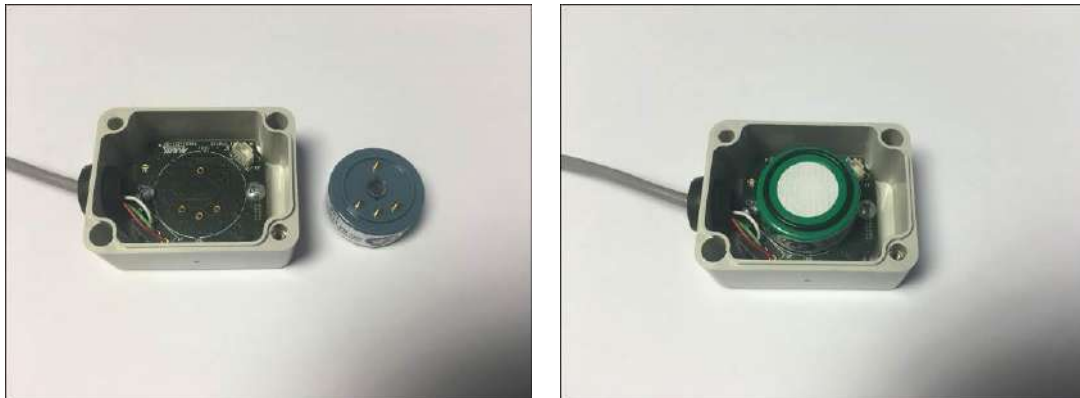

- 5] Refit the lid and secure with the corner lid screws using a Pozi Pan screwdriver.

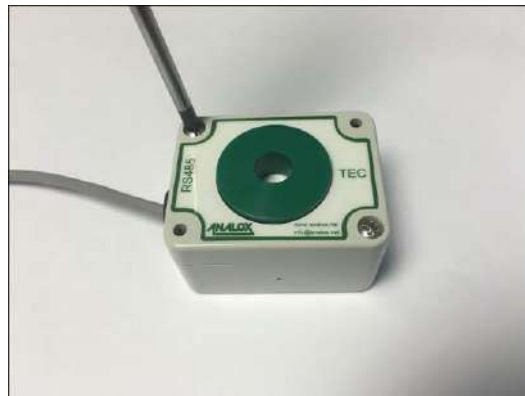

- 6] Following a carbon monoxide cell replacement a full calibration MUST be performed, as described in section 3.5.
- 7] If the cell replacement reminder option is in use then the reminder must be manually reset after replacing the cell, as described in section 3.13.1.

8.3 Helium cell replacement

Replacement part number for your cell is: **VQ546MR**

Helium sensor replacement is done in the same way as shown in section 8.2.1 for the carbon monoxide cell sensor replacement.

- 1] Following a helium sensor cell replacement a full calibration **MUST** be performed, as described in section 5.4.8.
- 2] If the cell replacement reminder option is in use, then the reminder must be manually reset after replacing the cell, as described in section 3.13.1.

8.4 Reconfiguring a unit



CAUTION: THE PROCEDURE FOR RECONFIGURING A UNIT SHOULD BE PERFORMED UNDER THE UNDERSTANDING THAT IT WILL REMOVE ALL CURRENT SETTINGS FROM A UNIT AND WRITE DEFAULT SETTINGS FOR A NEW CONFIGURATION TO THE DEVICE. ONLY PERFORM THIS PROCEDURE IF YOU ARE CERTAIN YOU WISH TO RE-CONFIGURE A DEVICE.

It may occasionally be necessary to change the configuration of a unit to operate with a different sensor or range, for example, when configuring a spare SDA to be swapped out for another unit.

Re-configuration of a unit is performed by using XML configuration files. You may need to contact your supplier to be provided with a set of configuration files. Re-configuration is performed using the SDA software. In order for the configuration files to be available to the SDA software they should be placed in a folder named 'config' within the folder from which the SDA software runs. This will usually be at the location 'C:\Program Files\Analog\SDA Setup\config' but may vary depending on the location chosen on installation of the software. The SDA software should be closed and re-opened once the configuration files are correctly located.

Once the configuration files are available to the software, connect a device as per section 6.2 and access the 'Advanced' tab (**Figure 62**). From the drop down menu under 'Device configuration' select the appropriate configuration file and click 'Configure...'. A warning will be shown explaining the implications of re-configuring a device. Click OK to start the re-configuration.

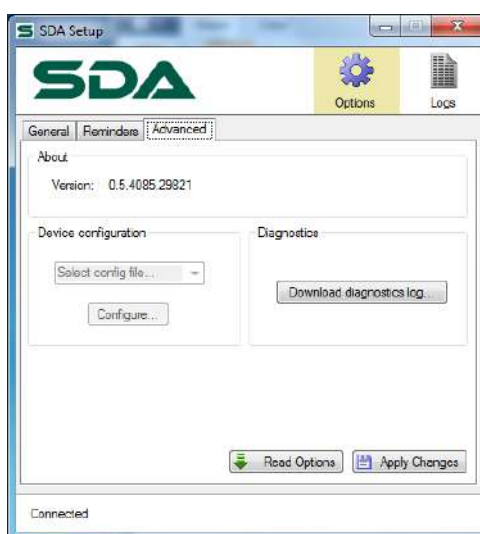

Figure 62 **Advanced options**

The new configuration shall be uploaded to the device and a sound will be played by the SDA when the upload is complete.



NOTE: FOLLOWING A RE-CONFIGURATION, THE DEVICE SHOULD BE POWERED DOWN AND RE-POWERED BEFORE USE.

9 Spares and accessories

9.1 Spares

Description	Part Number	Service / Replacement Intervals
SDA O₂ spares		
9212-9HM for MEC O ₂ Sensor Assembly	9100-9212-9HM	2 years
O ₂ MEC sensor module, 0-3000mbar O ₂	MECO2ABBP	As required
SDA CO spares		
Carbon monoxide sensor only	9100-2030S	2 years
CO MEC sensor module, 0-20ppm	MECCOEBAP	As required
SDA CO+ spares		
Carbon monoxide sensor only	CO-B4	2 years
CO TEC sensor module, 0-20ppm	TECCOBANP	As required
SDA He spares		
Helium sensor only	VQ546MR	5 years
He MEC sensor module, 0-100% in N ₂	MECHEMBDP	As required
Spare CO₂ modules		
CO ₂ Module, Rack, - 0-5000ppm	SDARCO2ASN	5 years
CO ₂ Module, Panel, - 0-5000ppm	SDAPCO2ASN	5 years
CO ₂ Module, Rack, - 0-2%	SDARCO2BBN	5 years
CO ₂ Module, Panel, - 0-2%	SDAPCO2BBN	5 years
Other spares		
Flow Meter for CO ₂ Module/Flow Meter Panel	5981-0502	As required

9.2 Accessories

Description	Part Number
MEC/TEC & OM Bracket Kit	XK0-472K
MEC/TEC Only Bracket Kit	XK0-473K
SDA combined panel mount adaptor plate kit.	XK0-445K
Universal Plug-In Monitor Power Supply	XK0-667
Output Module - Current	SDAOMCURRENT
Flow Meter Panel - Panel Mount	SDAFMPANEL
Flow Meter Panel - Rack Mount	SDAFMRACK
SDA Phoenix connector pack	SDAMONCON
Flow adaptor	8000-0069A
Bridge zone filter (For SDA's ordered after March 2019)	7000-0238-0001
Bridge zone filter (for SDA's ordered prior to March 2019)	2533-1005

9.3 Recommended calibration gases

9.3.1 Oxygen

Item	Description	Part no.
1	0.5LPM 110L bottle regulator	Contact Analox or source locally
2	Zero calibration gas, 100% nitrogen	Contact Analox or source locally
3	Span calibration gas, 100% oxygen	To be sourced locally

9.3.2 Carbon dioxide (N2 background gas)

Item	Description	Part no.
1	0.5LPM 110L bottle regulator	Contact Analox or source locally
2	Zero calibration gas, 100% nitrogen	Contact Analox or source locally
3	Span calibration gas (0.5% CO ₂ balance N ₂) (5000ppm variants)	Contact Analox or source locally

9.3.3 Carbon dioxide (He background gas)

Item	Description	Part no.
1	0.5LPM 110L bottle regulator	Contact Analox or source locally
2	Zero calibration gas, 100% helium	Contact Analox or source locally
3	Span calibration gas (0.5% CO ₂ balance He) (5000ppm variants)	Contact Analox or source locally

9.3.4 Carbon monoxide (N2 background gas)

Item	Description	Part no.
1	0.5LPM 110L bottle regulator	Contact Analox or source locally
2	Zero calibration gas (20.9% oxygen, balance nitrogen)	Contact Analox or source locally
3	Span calibration gas (18ppm carbon monoxide, 20.9% oxygen, balance nitrogen)	Contact Analox or source locally

9.3.5 Carbon monoxide (He background gas)

Item	Description	Part no.
1	0.5LPM 110L bottle regulator	Contact Analox or source locally
2	Zero calibration gas (20.9% oxygen, balance helium)	Contact Analox or source locally
3	Span calibration gas, (18ppm carbon monoxide, 20.9% oxygen, balance helium)	Contact Analox or source locally

9.3.6 Helium (N2 and air variants)

Item	Description	Part no.
1	0.5LPM 110L bottle regulator	Contact Analox or source locally
2	Zero calibration gas (100% nitrogen)	Contact Analox or source locally
3	Span calibration gas, (100% helium)	Contact Analox or source locally

9.4 Servicing

Only the cells of the oxygen sensor, the carbon monoxide sensor, the helium sensor and the VOC sensor are designed to be user replaceable. Please consult Analox if any other parts from a SDA module require replacement.

10 Specifications

10.1 SDA monitor

Power Source	External stabilised 12-32V DC supply, (regulation < $\pm 300\text{mV}$). NOTE: Depth SDA requires 12-28VDC supply (range limited by sensor). External 110-230V AC supply (option only).
	NOTE: FOR CERTAIN INSTALLATIONS A BRIDGE ZONE POWER FILTER WILL BE REQUIRED, SEE SECTION 3.4.2 FOR DETAIL
Operating Current	SDA Monitor: Maximum 640mA at 24V DC supply SDA O ₂ System: Average 200mA at 24V DC supply SDA CO System: Average 200mA at 24V DC supply SDA CO ₂ System: Average 300mA at 24V DC supply SDA He System: Average 300mA at 24V DC supply SDA T&H System: Average 300mA at 24V DC supply SDA Depth System: Average 300mA at 24V DC supply
Fuses	Monitor: Internal resettable fuse. Sensor and data ports: 400mA shutdown protection on +5V DC supply.
Display Panel	320 x 240 TFT colour graphic display with 10 brightness levels. Displays current values of measured parameters using 14mm high large characters.
Alarm Indicators	Onscreen visual indication of faults and 2 fully adjustable alarm levels. (optional volt free contacts for individual alarms with SDA Output Module)
Operator Controls	2 x momentary action toggle switches for alarm and calibration functions 2 x momentary action push buttons for mute and function selection 1 x rotary encoder for value adjustment and menu navigation
Environmental Conditions	Rating: IP22 Operating temperature: -5 to +55°C Storage temperature: -10 to +70°C Humidity: 0 to 95% RH at +55°C non-condensing
Dimensions	Rack: 106(w) x 129(h) x 60(d)mm (Depth includes encoder and earth stud) Panel: 120(w) x 133(h) x 60(d)mm (Depth includes encoder and earth stud)
Weights	Rack: 595g Panel: 665g
Audio	Speaker: 1W, used for user interface navigation. Buzzer: 88dB at 10cm, frequency 2400 \pm 400Hz, alarm and fault indication.
Operational life	The product is expected to achieve an operational life of at least 10 years with anticipated continuous usage for periods of 30 days in typical applications.

10.2 MEC oxygen sensor

Power Source	+5V DC \pm 500mV
Operating Current	Maximum 20mA at +5V DC supply
Detection Mode	Electrochemical
Range and Accuracies	100% O₂ : \pm 0.035% O ₂ , \pm 1% of reading, \pm 0.5% of reading / °C 3000mbar ppO₂ : \pm 0.35mbar ppO ₂ , \pm 1% of reading, \pm 0.5% of reading / °C
Response Time	T90 in <15seconds
Communication Link	RS485 serial data, 9600bps, no parity, 1 stop bit. Distance up to 500m
Environmental Conditions	Rating: IP65 Operating temperature: -5 to +55°C *Storage temperature: -10 to +70°C Operating pressure: Atmospheric variant: 700 to 1100 mbar absolute Air diving variant: 0 to 10bar gauge Saturation diving variant: Remote pressure up to 40bar gauge Humidity: 0 to 99% RH at +55°C non-condensing
Dimensions	65 x 50 x 35 mm
Weights	99g
Sensor Life	2 years for the electrochemical cell in atmospheric air
Remote sensor gas flow rate	0.2 to 1.0 litres/minute

* Note that if the sensor is to be stored below -10°C or above 55°C then the electrochemical cell should be removed from the unit and stored in a warmer environment so as to prevent the electrolyte from freezing and causing damage to the cell.

10.3 Carbon dioxide sensor

Power Source	+5V DC \pm 500mV
Operating Current	CO ₂ Sensor: Maximum 390mA at +5V DC supply
Detection Mode	Infra-red
Range and Accuracies	5000ppm CO₂ : \pm 25ppm CO ₂ , \pm 1% of reading, \pm 2.5ppm CO ₂ / °C
Response Time	T90 in <30seconds
Warm Up Time	40 seconds
Communication Link	RS485 serial data, 9600bps, no parity, 1 stop bit. Distance up to 500m
Environmental Conditions	Rating: IP22 Operating temperature: -5 to +55°C Storage temperature: -10 to +70°C Operating pressure: 700 to 1100 mbar absolute Humidity: 0 to 95% RH at +55°C non-condensing
Dimensions	Rack: 106 x 129 x 194mm Panel: 120 x 133 x 194mm
Weights	Rack: 1393g Panel: 2081g
Sensor Life	5 years in operation
Remote sensor gas flow rate	0.2 to 1.0 litres/minute Maximum sample input pressure 6bara

10.4 MEC carbon monoxide sensor (For SDA CO)

Power Source	+5V DC \pm 500mV
Operating Current	Maximum 20mA at +5V DC supply
Detection Mode	Electrochemical
Range and Accuracies	20ppm CO: \pm 1ppm CO, \pm 5% of reading, \pm 0.5ppm of reading / °C
Response Time	T90 in <25seconds
Communication Link	RS485 serial data, 9600bps, no parity, 1 stop bit. Distance up to 500m
Environmental Conditions	Rating: IP65 Operating temperature: -5 to +55°C *Storage temperature: -10 to +70°C Operating pressure: 800 to 1100 mbar absolute Humidity: 0 to 99% RH at +55°C non-condensing
Dimensions	65 x 50 x 35 mm
Weights	99g
Sensor Life	2 years for the electrochemical cell in atmospheric air
Remote sensor gas flow rate	0.2 to 1.0 litres/minute

* Note that if the sensor is to be stored below -10°C or above 55°C then the electrochemical cell should be removed from the unit and stored in a warmer environment so as to prevent the electrolyte from freezing and causing damage to the cell.

10.5 TEC carbon monoxide sensor (For SDA CO+)

Power Source	+5V DC \pm 500mV
Operating Current	Maximum 20mA at +5V DC supply
Detection Mode	Electrochemical
Range and Accuracies	20ppm CO: \pm 0.1ppm CO, \pm 3% of reading, \pm 0.7ppm of reading / °C
Response Time	T90 in <25seconds
Communication Link	RS485 serial data, 9600bps, no parity, 1 stop bit. Distance up to 500m
Environmental Conditions	Rating: IP65 Operating temperature: -5 to +55°C *Storage temperature: -10 to +70°C Operating pressure: 800 to 1100 mbar absolute Humidity: 0 to 99% RH at +55°C non-condensing
Dimensions	65 x 50 x 35 mm
Weights	99g
Sensor Life	2 years for the electrochemical cell in atmospheric air
Remote sensor gas flow rate	0.2 to 1.0 litres/minute
The SDA CO+ meets the accuracy requirements to detect CO gas outlined in NORSOK U-100, Section 5.2.3.6.3, Table 4 and BS 8478, Section 4.7, Table 5	

* Note that if the sensor is to be stored below -10°C or above 55°C then the electrochemical cell should be removed from the unit and stored in a warmer environment so as to prevent the electrolyte from freezing and causing damage to the cell.

10.6 Temperature & humidity probe

Power Source	+5V DC \pm 500mV
Range and Accuracies	0 to 100°C (32 to 212 °F) and 0 to 100%RH \pm 3°C (temperature) \pm 10% RH (humidity)
Response Time	τ_{63} : 3 to 12 seconds
Communication Link	RS485 serial data, 19200bps, no parity, 1 stop bit. Distance up to 500m
Environmental Conditions	Rating: IP22 Operating temperature: -5 to +55°C Storage temperature: -10 to +70°C Operating pressure (Chamber version): 35 bar absolute Operating pressure (In-line version): 100 bar absolute Humidity: 0 to 95% RH at +55°C non-condensing
Sensor Life	5 years in operation

10.7 Pressure sensor & 4-20mA MEC

Power Source	Pressure sensor – 12-28V DC (Supplied by SDA via 4-20mA MEC) 4-20mA MEC - +5V DC \pm 500mV
Operating Current	Pressure sensor – 30mA Maximum 4-20mA MEC - 20mA Maximum
Range and Accuracies	600MSW max \pm 0.30%FS
Communication Link	Pressure sensor - 4-20mA, 2 wire (Active) 4-20mA MEC - RS485 serial data, 9600bps, no parity, 1 stop bit.
Environmental Conditions	Rating: IP65 Operating temperature: -5 to +55°C Storage temperature: -10 to +70°C Humidity: 0 to 95% RH at +55°C non-condensing
Dimensions	Diameter = 30mm, Length = 120mm
Weights	240g

10.8 Pressure sensor & APT RS485 module

Power Source	Pressure sensor – 12-28V DC (Supplied by local DC supply) APT RS485 module - +5V DC ±500mV
Operating Current	Pressure sensor – 30mA Maximum APT RS485 module - 30mA Maximum
Range and Accuracies	Low pressure system – 10bara High pressure system – 40bara DNV-OS-E402 (October 2010) 0 to 30msw = ±0.25msw 30msw to FS = ±0.30%FS <i>*To meet DNV accuracies a yearly calibration is required</i>
Communication Link	Pressure sensor – RS485, 2 wire APT RS485 module - RS485 serial data, 9600bps, no parity, 1 stop bit.
Environmental Conditions	Rating: IP65 Operating temperature: -5 to +55°C Storage temperature: -10 to +70°C Humidity: 0 to 95% RH at +55°C non-condensing
Dimensions	Diameter = 30mm, Length = 120mm
Weights	240g

10.9 MEC helium sensor

Power Source	+5V DC \pm 500mV
Operating Current	Maximum 80mA at +5V DC supply
Detection Mode	Pellistor
Range and Accuracies	<p>0 to 100% He</p> <p>\pm 3%FS + (Temp coefficient) if operating as a stand-alone sensor</p> <p>\pm 2%FS + (Temp coefficient) when networked to and compensated by an O2 SDA</p> <p>Temperature coefficient = 0.05 %FS/°C or 0.028 %FS/°F</p>
Response Time	T50 in <10seconds
Communication Link	RS485 serial data, 9600bps, no parity, 1 stop bit. Distance up to 500m
Environmental Conditions	<p>Rating: IP65</p> <p>Operating temperature: -5 to +55°C</p> <p>*Storage temperature: -10 to +70°C</p> <p>Operating pressure: 700 to 1100 mbar absolute</p> <p>Humidity: 0 to 99% RH at +55°C non-condensing</p>
Dimensions	65 x 50 x 35 mm
Weights	99g
Sensor Life	Up to 5 years
Remote sensor gas flow rate	0.2 to 1.0 litres/minute

10.10 SDA Output Module

Power Source	+5V DC \pm 500mV
Operating Current	Maximum 300mA at +5V DC supply
Range and resolution	0 to 23mA FS, 0.023mA
Communication Link	RS485 serial data, 9600bps, no parity, 1 stop bit. Distance up to 500m
Outputs	<p>2 x relays (1 per alarm), volts free, changeover contacts</p> <p>- Maximum ratings: 125 VAC, 60 VDC, 1 A, 62.5 VA, 30 W</p> <p>1 x 4 to 20mA Isolated output (short circuit protected)</p> <p>- Maximum load resistance 500Ω standard, 1k Ω high compliance.</p> <p>1 x status LED</p>
Environmental Conditions	<p>Rating: IP22</p> <p>Operating temperature: -5 to +55°C</p> <p>Storage temperature: -10 to +70°C</p> <p>Humidity: 0 to 95% RH at +55°C non-condensing</p>
Dimensions	98 x 64 x 38 mm
Weights	118g without cables

10.11 IP rating and general care

The SDA Monitor is designed to provide an IP22 rating for the front panel of the SDA Monitor. The Monitor should be fitted into a suitable rack or panel to cover the rear of the unit to provide protection over the rear connectors to at least IP22.

Although designed to be water resistant the MEC oxygen sensors should not be intentionally immersed in liquid or left outside unprotected.

To clean the user interface of the SDA equipment, use a damp soft cloth.

11 Warranty information

We provide the following Warranties for the SDA and associated accessories

- A 1 year electronics warranty.
- A 2 year graded O2 sensor warranty.
- A 2 year CO2 sensor warranty.
- For all other sensors the warranty is 1 year.

In both cases the warranty period runs from the date of our invoice.

We warrant that the equipment will be free from defects in workmanship and materials.

The warranty does not extend to and we will not be liable for defects caused by the effects of normal wear and tear, erosion, corrosion, fire, explosion, misuse, use in any context or application for which the equipment is not designed or recommended, or unauthorised modification.

Following a valid warranty claim in accordance with the above, the equipment, upon return to us, would be repaired or replaced without cost or charge but in our discretion we may elect instead to provide to you whichever is the lesser of the cost of replacement or a refund of net purchase price paid as per our Invoice on initial purchase from us. We shall have no liability for losses, damages, costs or delays whatsoever. We shall have no liability for any incidental or consequential losses or damages. All express or implied warranties as to satisfactory or merchantable quality, fitness for a particular or general purpose or otherwise are excluded and no such Warranties are made or provided, save as set out in this clause.

In order to effectively notify a warranty claim, the claim with all relevant information and documentation should be sent in writing to:

Analox Ltd
15 Ellerbeck Court
Stokesley Business Park
Stokesley
North Yorkshire
TS9 5PT

Or by e-mail to : info@analoxgroup.com

We reserve the right to require from you proof of dispatch to us of the notification of warranty claim by any of the above alternative means.

The equipment should not be sent to us without our prior written authority. All shipping and Insurance costs of returned equipment are to be borne by you and at your risk. All returned items must be properly and sufficiently packed.

12 Fault reporting To Analox

Date	
-------------	--

Customer Details

Customer Contact	
Address	
Country	
Telephone	
Fax	
Email	

Equipment Details (where applicable)

Monitor Serial No	
Sensor Serial No	
Output Module Serial No	
Others	

System Operating Voltage	
---------------------------------	--

Customer's Description of Fault

To be completed by Analox

Date Manufactured	
Monitor SW Version	
Monitor BSP Version	
Design Change Note Ref (if applicable)	
Comments	

13 UK Declaration of Conformity

UK Declaration of Conformity

Declaration number: XK0-C003-02

Manufacturer's name: Analox Limited

Manufacturer's address: 15 Ellerbeck Court
Stokesley Business Park
Stokesley
North Yorkshire
TS9 5PT

It is declared that the following product:

Product name: SDA
Product code: SDAPxxxxxxxx
SDARxxxxxxxx

Conforms to all applicable requirements of: IACS E10: 2023
IEC 60533:2015
BS EN60945: 2002

- Complies with the Electromagnetic Compatibility Regulations 2016
- Complies with the requirements of UK RoHS Directive 2015/863
- Complies with the requirements of WEEE Regulations 2013

The above product is UKCA-marked and satisfies the relevant legislative requirements of the UK



Signed on behalf of: Analox Limited

Date: 25th July 2024

Signed: 

Name: Paul Branton
Position: Technical Director

14 Declaration of Conformity

Declaration of conformity

Declaration number: XK0-919-06

Manufacturer's name: Analox Limited

Manufacturer's address: 15 Ellerbeck Court
Stokesley Business Park
Stokesley
North Yorkshire
TS9 5PT

It is declared that the following product:

Product name: SDA
Product code: SDAPxxxxxxxx
SDARxxxxxxxx

Conforms to all applicable requirements of: IACS E10: 2023
IEC 60533:2015
EN 60945: 2002

- Complies with the requirements of the EMC Directive 2014/30/EU
- Complies with the requirements of the RoHS Directive 2015/863
- Complies with the requirements of the WEEE Directive 2012/19/EU

The above product complies with IMCA Diving Equipment Systems Inspection Guidance Notes; DO23:2000 Design for Surface Orientated (Air) Diving Systems and DO24:2001 Design for Saturation (Bell) Diving Systems.

The above product complies with the requirements of DNV-OS-E402 Offshore Standard for Diving Systems, October 2010 on the basis of Analox document RM-007-03, which is available on the Analox website.

CE The above product is CE-marked and satisfies the relevant legislative requirements of the European Economic Area (EEA)



Signed on behalf of: Analox Limited

Date: 25th July 2024

Signed:

Name: Paul Branton
Position: Technical Director

15.1 WEEE statement



According to WEEE regulation this electronic product cannot be placed in household waste bins. Please check local regulations for information on the disposal of electronic products in your area.

Analox will provide a disposal service if this is beneficial to the customer. Analox are registered for the disposal of WEEE in the UK through the Environment Agency (2013 Registration number WEE/KE0043SY).

v