



User and Maintenance Manual

EK76

Rev. 11.19

If you have any questions on this equipment please contact Technical Support at:

Nuvair
1600 Beacon Place
Oxnard, CA 93033

Phone: +1 805 815 4044

Fax: +1 805 486 0900

Email: info@nuvair.com

Hours: Monday through Friday
8:00 AM to 5:00 PM PST USA

Warning

This User Manual contains important safety information and should always be available to those personnel operating this equipment. Read, understand, and retain all instructions before operating this equipment to prevent injury or equipment damage.

Every effort was made to ensure the accuracy of the information contained within. Nuvair, however, retains the right to modify its contents without notice. If you have problems or questions after reading the manual, stop and call Nuvair at +1 805 815 4044 for information.

GENERAL INFORMATION

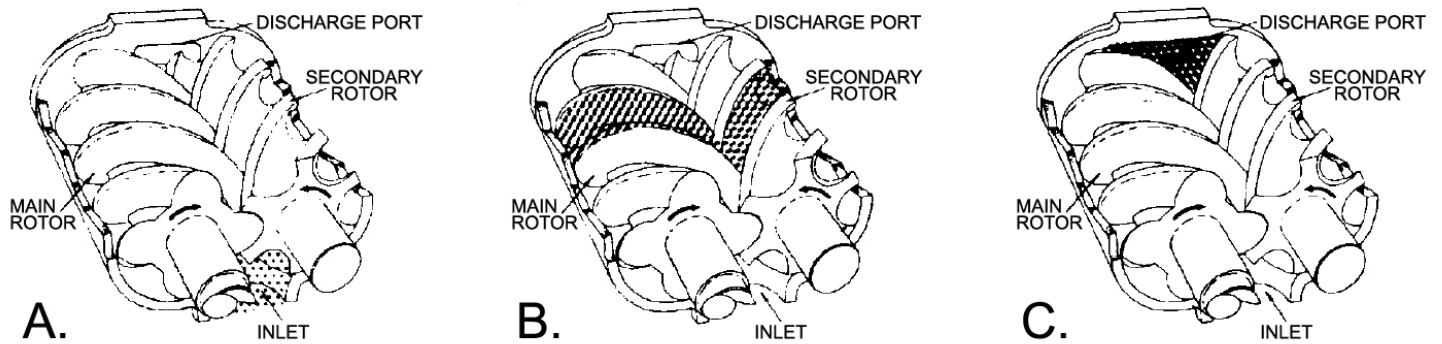

COMPRESSOR - The rotary screw compressor is a single stage, positive displacement rotary machine using meshing helical rotors to effect compression. Both rotors are supported between high capacity antifriction bearings located outside the compression chamber. Roller bearings are used at the inlet end of the rotors to carry part of the radial loads. Angular contact ball and roller bearings at the discharge end locate each rotor axially and carry all thrust loads and the remainder of the radial loads.

COMPRESSION PRINCIPLE - Compression is accomplished by the main and secondary rotors synchronously meshing in a one-piece cylinder. The main rotor has five (5) helical lobes 90° apart. The secondary rotor has six (6) matching helical grooves 72° apart to allow meshing with main rotor lobes.

The air inlet port is located on top of the compressor cylinder near the drive shaft end. The discharge port is near the bottom at the opposite end of the compressor cylinder. *Figure 1-1 is an inverted view to show inlet and discharge ports.* The compression cycle begins as the rotors unmesh at the inlet port and air is drawn into the cavity between the main rotor lobes and the secondary rotor grooves (A). When the rotors pass the inlet port cutoff, air is trapped in the interlobe cavity and flows axially with the meshing rotors (B). As meshing continues, more of the main rotor lobe enters the secondary rotor groove, normal volume is reduced and pressure increases.

Oil is injected into the cylinder to remove the heat of compression and seal internal clearances. Volume reduction and pressure increase continues until the air/oil mixture trapped in the interlobe cavity by the rotors passes the discharge port and is released to the oil reservoir (C). Each rotor cavity follows the same "fill-compress-discharge" cycle in rapid succession to produce a discharge air flow that is continuous, smooth and shock free.

AIR FLOW IN THE COMPRESSOR SYSTEM (Figure 1-3) - Air enters the air filter and passes through the inlet unloader valve and on into the compression chamber where oil is injected into the air. After compression, the air/oil mixture passes into the oil reservoir where most of the entrained oil is removed by velocity change and impingement and drops back into the reservoir. The air and remaining oil then passes through the air/oil separator. The air then passes through the minimum pressure/check valve, the after cooler and the optional moisture separator and into the plant air lines.

LUBRICATION, COOLING AND SEALING - Oil is forced by air pressure from the oil reservoir through the oil cooler, thermostatic mixing valve, and oil filter and discharge into the compressor main oil gallery. A portion of the oil is directed through internal passages to the bearings and shaft oil seal. The balance of the oil is injected directly into the compression chamber to remove heat of compression, seal internal clearances and lubricate the rotors.

OIL COOLER, OIL FILTER & SEPARATOR

COMPRESSOR OIL SYSTEM - Lubricating oil is employed to absorb the heat of compression, lubricate moving parts and seal internal clearances between the rotor and the air cylinder. Pressure differential between the air/oil sump and the final injection point into the compressor is used to move the oil mass through the various oil system components. Refer to Figure 4-8 for the arrangement of the oil system components - they are highlighted in blue for identification ease.

Oil exits the air/oil sump and is delivered to the heat exchange and thermal mixing valve, where cold (oil cooler branch) and hot (oil bypass branch) are mixed to the desired compressor injection temperature. The tempered oil is cleansed via the oil filter before injection into the compressor casing.

RECOMMENDED LUBRICANT – The EK76 compressor is factory filled with Nuvair 546 is an ISO Grade 46 and NSF-registered H1 food grade compressor oil. These lubricants are formulated to the highest quality standards and are factory authorized, tested and approved for use in rotary screw compressors. Nuvair 546 is available at www.nuvair.com.

OIL LEVEL INDICATOR (GAUGE) indicates the amount of oil in the oil reservoir - See below for details. Read oil level when unit is shut off and the foam has settled out. In operation the oil level will fluctuate as the compressor loads and unloads. Adequate oil level falls between the MAX and MIN limits of the sight glass:

- The approximate oil system total capacity is 1.0 Gals (5 L)
- The differential between "MAX" and "MIN" levels on sight glass is 0.7 Gal (2.8 L).

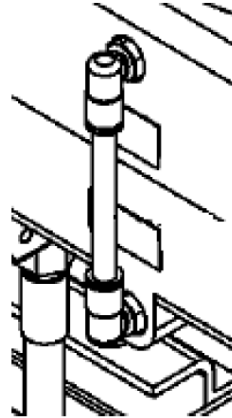

Before draining, adding, or changing the lubricant oil in the compressor, be aware of the following hazards associated with these tasks:

⚠ DANGER



Air/oil under pressure will cause severe personal injury or death. Shut down compressor, relieve system of all pressure, disconnect, lockout and tagout power supply to the starter before removing valves, caps, plugs, fittings, bolts and filters.

⚠ CAUTION

Compressor, air/oil reservoir, separator chamber and all piping and tubing may be at high temperature during and after operation. Use of improper lubricants will cause damage to equipment. Do not mix different types of lubricants or use inferior lubricants.

⚠ CAUTION

Use of improper lubricants will cause damage to equipment. Do not mix different types of lubricants or use inferior lubricants.

⚠ CAUTION

Improper equipment maintenance with use of synthetic lubricants will damage equipment. Oil filter and oil separator change intervals remain the same.



LUBRICANT CHANGE PROCEDURE

1. Be sure the unit is completely off and that no air pressure is in the oil reservoir.
2. Disconnect, tag and lockout the power supply to the starter.
3. Thoroughly drain oil system while hot:
 - Remove the plug and open the drain valve at the lower left hand side of the oil core tank. Once the oil has been drained, close the drain valve and reinstall the plug.
 - Remove and drain oil from the oil filter. Reinstall the used filter.
4. Fill the system with a 50 percent charge of the new lubricant:
 - Start the machine and monitor its operation.
 - Allow the machine to reach a stable discharge temperature (5-7min), then shut down.
5. Thoroughly drain oil system.
 - Replace used oil filter and air/oil separator element with new ones.
6. Fill the system with a full charge of the new lubricant.
7. Machine should then be run normally; however, total run time after the initial change-out should be 50 percent of normal anticipated service life of the new lubricant.
8. Drain all lubricant from the system, change the filter and separator, and replace with a full charge of the new lubricant.
9. Subsequent lubricant change-outs should be at normal intervals. See "Oil Change Interval" for details.

ADDITION OF OIL BETWEEN CHANGES must be made when the oil level is below the minimum level of the sight glass as read while the unit is completely off and blown down, and the foam has settled out.

1. Be sure the unit is completely off and that no air pressure is in the oil reservoir.
2. Disconnect, lockout and tagout the power supply to the starter.
3. Wipe away all dirt around the oil filler plug located on top of the oil sump.
4. Remove the oil filler plug and add oil as required to return the oil level to the middle of the sight gauge.
5. Install oil filler plug, run and check for leaks.

DO NOT OVERFILL (you should see oil slightly above the full line after running fully loaded and then shut down the machine and allow the foam to settle out). Adjust the quantity required to raise the oil level from "ADD" to "FULL". Repeated addition of oil between oil changes may indicate excessive oil carry-over and should be investigated.



Excessive oil carry-over can damage equipment. Never fill oil reservoir above the "FULL" marker.

OIL CHANGE INTERVAL - Recommended oil change intervals are based on oil temperature - see below for typical trends for the lubricant (Nuvair 546).

When operating conditions are severe (very dusty, high humidity, etc.), it will be necessary to change the oil more frequently. Operating conditions and the appearance of the drained oil must be surveyed and the oil change intervals planned accordingly by the user.

Discharge Temperature	Nuvair 546 Change Interval
Up to 180° F (82° C)	2000 hrs
180° to 190° F (82° C to 88° C)	1500 hrs
190° to 200° F (88° C to 93° C)	1000 hrs
200° F+ (93° C)	500 hrs

DRAINING AND REFILLING THE OIL SYSTEM - Always drain the complete system. Draining when the oil is hot will help to prevent varnish deposits and carry away impurities.

1. Be sure the unit is completely off and that no air pressure is in the oil reservoir.
2. Disconnect, lockout and tagout the power supply to the starter.
3. Thoroughly drain oil system while system is hot:
 - Remove the plug and open the drain valve at the lower left hand side of the oil core tank. Once the oil has been drained, close the drain valve and reinstall the plug. Make sure to provide a suitable pan to catch the 1.3 gal. (5 l) oil charge.
 - If the drained oil and/or oil filter element is contaminated, discontinue this procedure and follow instead the "Lubricant Change Procedure" in this Section.
4. Replace both used oil filter and air/oil separator element with new ones.
 - Remove each spin-on element.
 - Clean each gasket face of the filter body.
 - Coat each new element gasket with clean lubricant used in the unit.
 - Screw each new element on the filter body and tighten by hand. Tighten 1/2 turn more after gasket makes contact. **DO NOT OVERTIGHTEN ELEMENT.**
5. Wipe away all dirt around the oil filler plug.
6. Remove the oil filler plug and add oil as required to return the oil level to the full marker on the gauge.
7. Install the oil filler plug and operate the unit for about a minute allowing oil to fill all areas of the system. Check for leaks.
8. Shut down unit, allowing the oil to settle, and be certain all pressure is relieved.
9. Add oil, if necessary, to bring level to "FULL."

Use only CLEAN containers and funnels so no dirt enters the reservoir. Provide for clean storage of oils. Changing the oil will be of little benefit if done in a careless manner.



Use only the replacement element shown on the filter tag or refer to the parts list for the part number.



Excessive oil carry-over can damage equipment. Never fill oil reservoir above the "FULL" marker.

Improper oil filter maintenance will cause damage to equipment. Replace filter element every 2000 hours of operation. More frequent replacement could be required depending on operating conditions. A filter element left in service too long may damage equipment.

MOISTURE IN THE OIL SYSTEM – During periods of low ambient temperatures, light duty cycles, high humidity, or in the event of thermal mixing valve malfunction, the oil charge residing in the sump may not reach a high enough temperature to keep water vapor from condensing as liquid water, a condition that contaminates the oil charge, may cause excessive oil carryover, or result in compressor failure.

To help the end user determine if the compressor package is operating under potential water condensing conditions, the charts below have been provided. To use, find the prevailing ambient temperature along the horizontal scale of the chart, move vertically from this point until intercepting the slanted line corresponding to the operating discharge pressure; and finally, move horizontally from this point to read the corresponding water vapor dew point on the vertical scale. The compressor discharge temperature must be maintained at a minimum of 10° F (5.5° C) above this dew-point temperature to prevent condensation accumulation in the lubricant reservoir. Note that the charts conservatively assume 100% relative humidity for the ambient air.

The presence of water in the oil may be identified by one of the following means:

- Oil drawn from the oil sampling valve attached to the sump.
- Oil volume drained during an oil exchange.
- Periodic (e.g., every 2000hrs) oil sample analyzed by a reputable laboratory.

If water is found in the oil, drain sufficient volume of oil until no visible water is found - the heavier water will collect at the low elevations of the oil system, thus it will likely be expelled first.

THERMOSTATIC MIXING VALVE. This device, housed within the compressor body, mixes hot and cooled oil and delivers a tempered mixture to the oil filter and finally the compressor injection port.

Its thermostatic element expands with heat – it will stroke from just opening to fully open state within a 27°F (15°C) temperature change. Within these two temperature limits the valve gradually mixes hot separator oil with cooled heat exchanger oil to maintain a nearly constant oil injection temperature.

Above this range of oil temperature, the valve blocks all hot oil and only cooled oil is delivered.

The valve's nominal setting is stamped on the valve body. It may be verified by immersing the valve assembly into an open container with lubricating oil, raising its temperature to its nominal setting and checking that the element strokes fully from closed to open.

- Valve opening temp = 158°F (70°C), fully open temp = 185°F (85°C)

OIL SUMP (RESERVOIR) - This device provides the inertial separation of air and oil streams discharged by the compressor - the bulk (98%) of the air/oil separation is done at this step. It also serves as a holding and degassing volume for the major portion of the oil charge. It provides limited air storage for control and gauge actuation.

AIR / OIL SEPARATOR - This device provides the final (2%) of the air/oil separation - typically 2ppm oil content at the final discharge of the compressor package. It is housed in a removable spin-on cartridge.

Its high level of performance may be affected by the following conditions:

- Compromised media (e.g., ruptured).
- Contaminated media (e.g., vanish, moisture, inadequate oil type).
- High oil level in oil sump.
- Blockage of oil return orifice.
- Abnormally frequent or fast depressurization cycles.

Oil separator element life cannot be predicted; it will vary greatly depending on the conditions of operation, the quality of the oil used and the maintenance of the oil and air filters. The condition of the separator can be determined by pressure differential or by inspection.

Separator Pressure Differential - The pressure drop across the separator is equivalent to the difference between the two (2) pressure sensors in use. Use the measured pressure difference to forewarn of a potentially contaminated air-oil separator element:

- The pressure differential value may be calculated by subtracting the system pressure value from the compressor discharge pressure value.
- A pressure differential of 8psi may indicate a moderately dirty element.
- A pressure differential of 15psi may indicate a severely dirty element – replace ASAP.



Using an oil separator element at excessive pressure differential can cause damage to equipment. Replace the separator when the pressure differential has reached 15psi.

OIL FILTER, AIR/OIL SEPARATOR ELEMENT INSPECTION PROCEDURE

1. Remove the spin-on element.
2. Clean the gasket seating surface of the head.
3. Inspect the element internals by shining a light unto the media surface. If signs of contamination (dirt, rust, varnish, etc.) or damage is evident, replace the element.
4. Before reassembly, coat the element gasket with the same lubricant used in the unit.
5. Screw on until gasket makes contact. Hand-tighten 1/3 to 1/2 turn extra.
6. Run the unit and check for leaks.

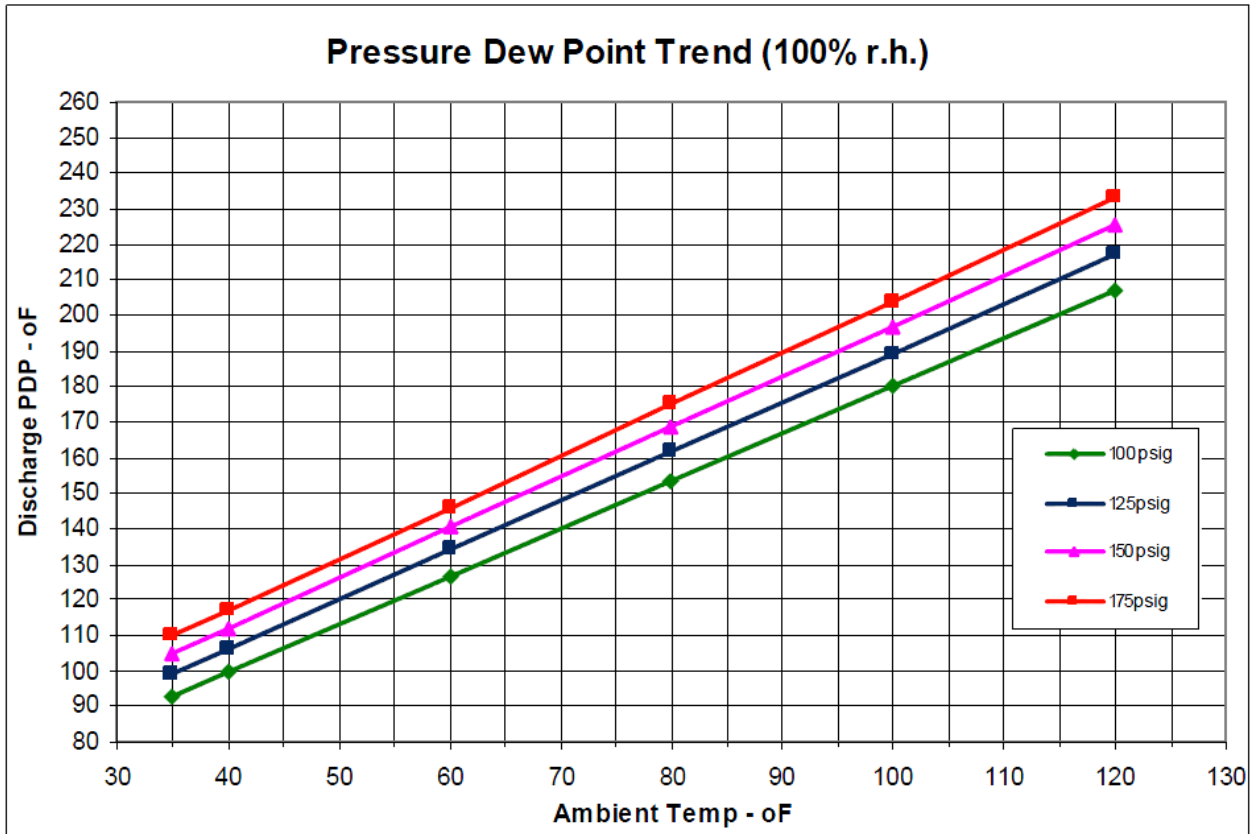

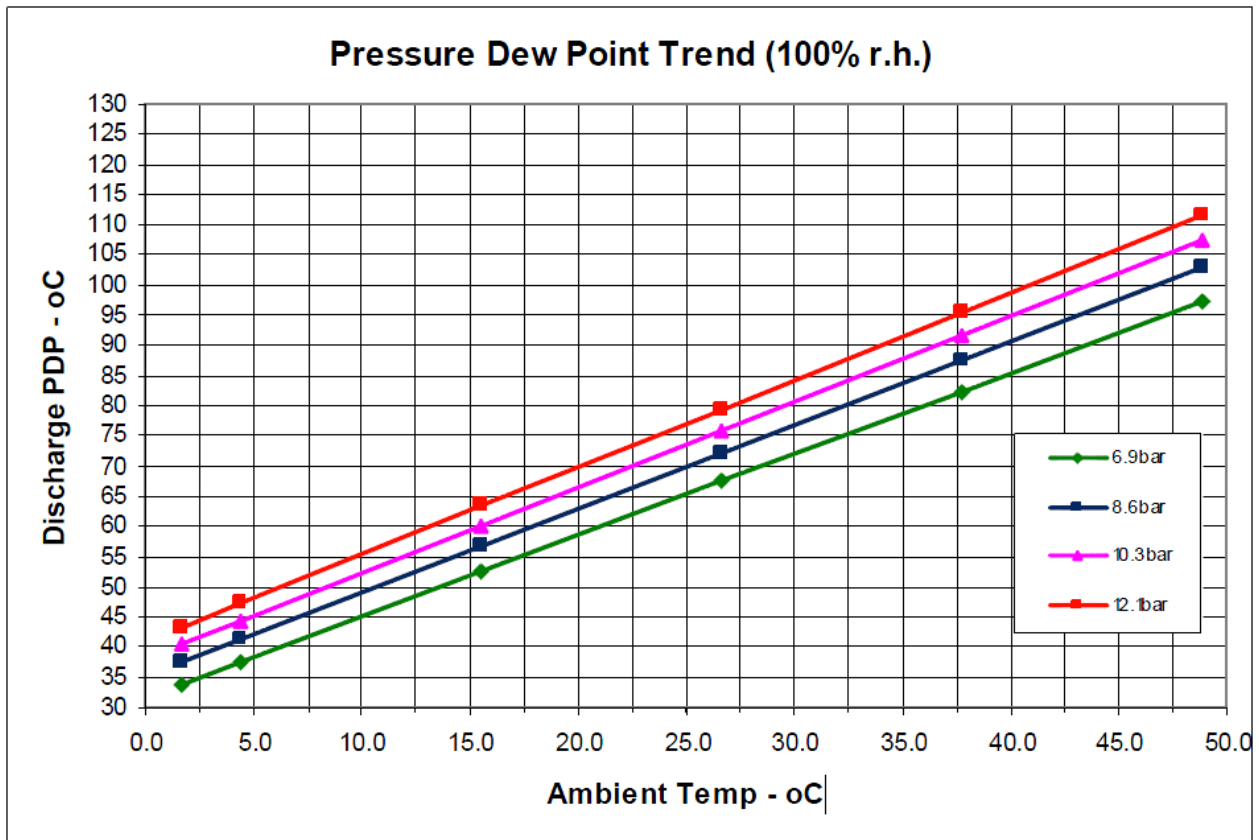

HEAT EXCHANGERS (OIL/AIR)

OIL/AIR HEAT EXCHANGERS – The heat of compression absorbed by the oil injected into the compressors (for cooling and lubrication) is ultimately rejected in a convenient medium such as air – for these air-cooled cores. Proper operation of the heat exchangers is essential for the following processes:

- The oil core maintains a compressor injection temperature 54°F above the ambient temperature while rejecting 9.7kW of heat from the 5.6gpm oil injection stream and operating at 110psig discharge pressure. The standard (Nuvair 546) lubricating and cooling oil must be kept at a normal operating temperature below 225°F in order to preserve its longevity.

AIR FILTERS

COMPRESSOR AIR FILTER - This device cleans the air stream entering the compressor inlet and is furnished as standard equipment on the compressor package. It is a single stage, high efficiency, cellulose media element housed in a non-corrosive housing.

Efficient compressor package operation depends on the unrestricted, clean supply of fresh air delivered by the air filter. In turn, the longevity of the filter element depends on the cleanliness of the local environment.

NOTICE

Use only genuine Gardner Denver air filter elements on Gardner Denver compressor units. Genuine parts are available through your authorized Gardner Denver distributor.



Do not oil this element. Do not wash in inflammable cleaning fluids. Do not use solvents other than water. Improper cleaning may damage the element.



Never operate the unit without the element. Never use elements that are damaged, ruptured or wet. Never use gaskets that won't seal. Keep spare elements and gaskets on hand to reduce downtime. Store elements in a protected area free from damage, dirt and moisture. Handle all parts with care.

FILTER ELEMENT INSPECTION AND/OR REPLACEMENT

1. Loosen and remove the fastening band (2) and remove the filter element.
2. Visually inspect the filter element (1). Replace it if:
 - Flaws (tears in media, damage to sealing surfaces) are evident.
 - Contamination (dirt, grease, etc.) is evident.
 - Recommended replacement period has been achieved – see below for details.
3. Install the air filter element (1) and the fastening band (2) in the reverse order.

SERVICING OF MISCELLANEOUS DEVICES

This section will cover basic maintenance of various control devices used with the compressor package. See below.

INLET CONTROL VALVE ASSEMBLY

Inlet-Valve Assembly - This device is located within and below the intake flange of the compressor – see schematic details.

During the loaded state, the inlet poppet remains open and enables atmospheric air to enter the compressor inlet - this is done by venting to atmosphere the gas trapped underside of the piston via check valve. During the unloaded state, a two-way solenoid valve feeds pressurized air underneath the piston, forcing it and the inlet poppet upward and blocking-off the compressor intake. A small purge check valve, located in the poppet, allows a stream of air to reach (e.g., purge) the rotors and keep them from unstable, noisy operation and producing sufficient pressure to maintain cooling / lubricating oil flow.

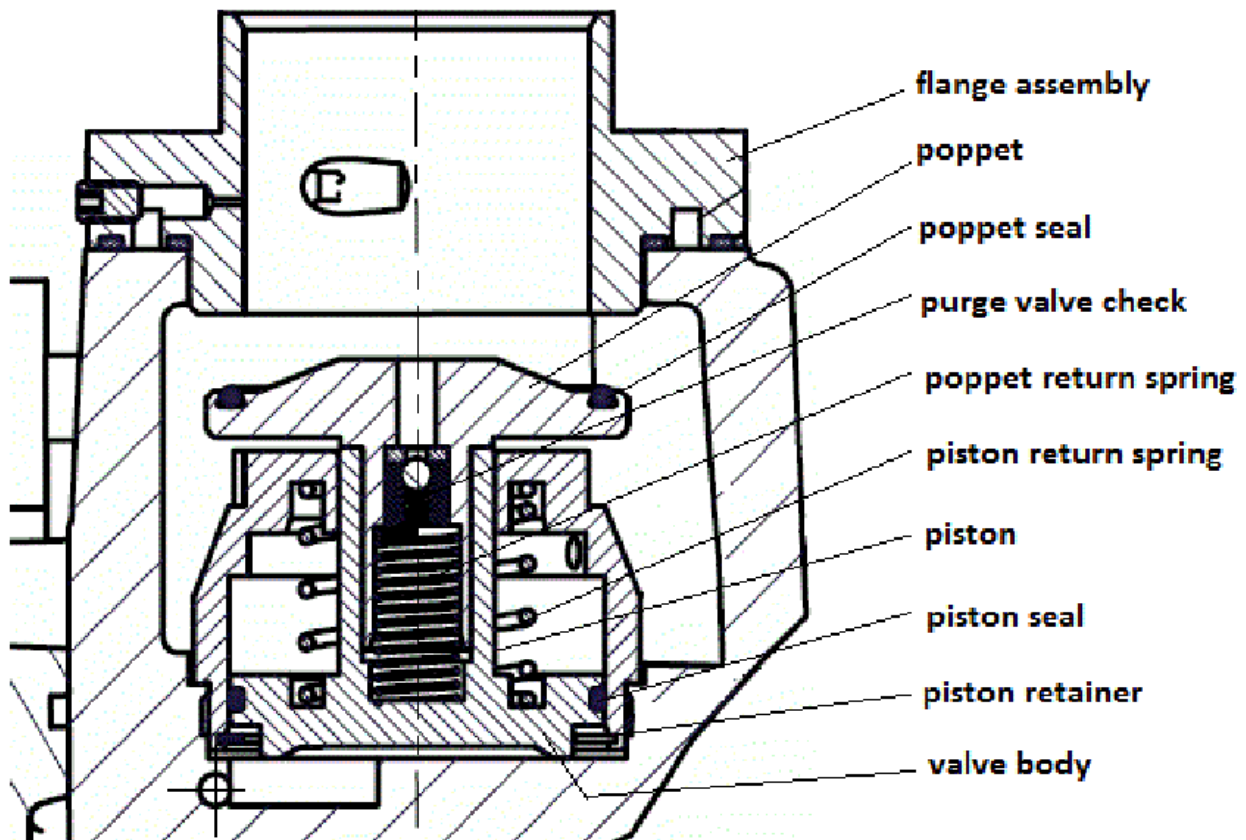

Air/oil pressure will cause severe personal injury or death. Shut down compressor, relieve system of all pressure, disconnect, lockout and tagout power supply to the starter before removing valves, caps, plugs, fittings, bolts and filters.

Inlet Valve (Body) Inspection - The valve does not require maintenance or lubrication. If air/oil leaks develop across the valve disc during pressurized conditions (e.g., machine stopped), valve seals should be inspected for wear and tear signs:

1. Be sure the unit is completely off and oil sump is depressurized.
2. Disconnect, lockout and tag out power supply to the compressor package.
3. Close (when provided) valve isolating compressor package from air system.
4. Loosen and remove the air filter element.
5. Remove four bolts securing inlet flange to the compressor body and remove the flange.
6. Remove the poppet assembly and the poppet return spring.
7. Unscrew the valve body from the compressor housing using the hex pattern provided on the valve body.
8. Inspect poppet seals (O-rings) for wear and tear.
9. In case of noted malfunction (e.g., valve will not open/close properly with good air signal), unless a damaged or worn component can be identified and/or repaired, replace the complete inlet valve assembly.

- Remove retainer ring to release piston assembly free.
- Inspect the piston seal and piston return spring. If any component is found worn or damaged,
- Replace the complete valve.

10. Re-assembly the piston assembly in reverse order.

11. Reinstall inlet valve in reverse order.

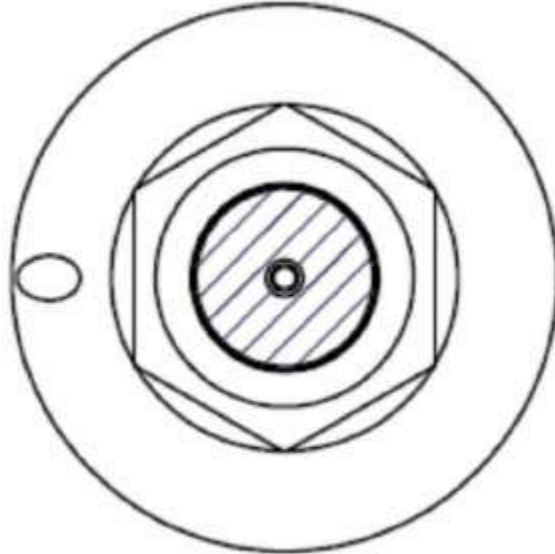

PRESSURE RELIEF VALVE

Pressure Relief Valve - This device protects the pressure-containing components of the compressor package against pressures exceeding 218 psig. It is installed on the wet-side of the oil sump.



Pressure Relief Valve



Before inspecting the pressure relief valve, release air pressure, lockout and tagout the power supply to the compressor package. Failure to release pressure or properly disconnect the power may result in personal injury or death.



Never paint, lubricate or alter a relief valve. Do not plug vent or restrict.



Operation of the unit with improper relief valve setting can result in severe personal injury or machine damage. Ensure properly set valves are installed and maintained.

Pressure Relief Valve Check During Operation - The pressure relief valve has no user-serviceable or repairable components. However, it should be tested for proper operation at least once every year. To test the pressure relief valve:

- Raise the system operating pressure to its normal level
- Pull the stem ring to open valve and let it vent for a few seconds.
- Release the stem ring to close the valve.

MINIMUM PRESSURE VALVE

Minimum Pressure Valve (MPV) Inspection – This device has no user-serviceable or repairable components. If it fails to maintain adequate minimum pressure (70psig) or fails to check the backflow of system compressed air after compressor stoppage, replace it as follows:

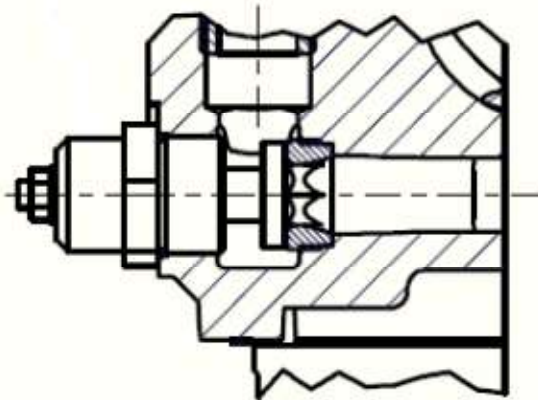

Minimum Pressure Valve and Seat



Air/oil pressure will cause severe personal injury or death. Shut down compressor, relieve system of all pressure, disconnect, lockout and tagout power supply to the starter before removing valves, caps, plugs, fittings, bolts and filters.

1. Be sure the unit is completely off and that no air pressure is in the oil reservoir and in the air cooled after cooler. Close the service valve.
2. Disconnect lockout and tagout the power supply to the starter.
3. Unscrew the minimum pressure valve assembly from compressor housing and remove.
4. Inspect the valve seat surface screwed into the compressor housing. Cleanse or replace – use 14mm hex wrench to unscrew. Note that fitting an O-ring on the hex wrench body helps hold the seat in position during installation.
5. Assemble the MPV assembly into the host manifold.
6. Run the unit and check for leaks.

7. If a new MPV has been fitted, its proper setting must be adjusted:
 - a. Make sure the site pipe system has a means to vent the compressor air to atmosphere with a valve. If this is not available, temporarily fit a 1/2" to 3/4" ball valve to achieve so.
 - b. Open the site vent valve to limit the dry sump pressure to about 40psig (2.8bar)
 - c. Loosen the jam nut on the TMV adjusting stem and screw it in until the wet sump reaches 70psig (4.8bar).
 - d. Tighten the jam nut on the TMV adjusting stem.
 - e. Close the site vent valve.

THERMOSTATIC MIXING VALVE

Thermostatic Mixing Valve (TMV) Inspection – This device has no user-serviceable or repairable components. If it fails to maintain adequate compressor discharge temperature, replace it as follows:

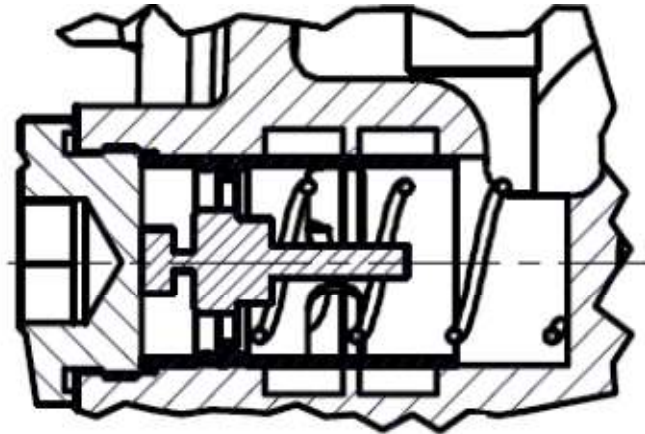

Thermostatic Mixing Valve

1. Be sure the unit is completely off and that no air pressure is in the oil reservoir and in the air cooled after cooler. Close the service valve.
2. Disconnect lockout and tagout the power supply to the starter.
3. Unscrew the hex cap holding the TMV assembly within the manifold block. Retrieve the TMV body and its spring from the compressor housing.
4. Inspect the valve seat surfaces for damage or foreign matter. Note its setting temperature – it is stamped on the valve seat area.
5. Immerse the valve body in a bath of compressor oil; heat the oil slowly and note the temperatures at which seat first starts moving and at it finally stops moving. Replace the device if one of the following conditions is present:
 - a. The valve doesn't start opening at temperature 181°F (98°C)
 - b. The seat fails to stroke fully at the correct temperature.
6. Assemble the TMV assembly into the housing in the reverse order.
7. Run the unit and check for leaks.

INPUT SHAFT SEAL ASSEMBLY

Input Shaft Seal Maintenance – This device has no user-serviceable or repairable components. If oil leaks past its seal and onto the external portion of the shaft, contact Nuair to have it inspected and/or repaired by a trained mechanic.

MAINTENANCE SCHEDULE

SERVICE CHECK LIST –

Air Filter and Pre-Filter - Operating conditions determine frequency of service. See “Air Filter,”

Every 8 Hours Operation

1. Check the reservoir oil level - add oil if required.
2. Observe if the unit loads and unloads properly.

Every 50 Hours Operation

1. Check/Change Package Inlet Filters.

Every 2000 Hours Operation

1. Change the compressor lubricant and oil filter element.. Under adverse conditions, **change more frequently.**

Every Year

Check the pressure relief valve for proper operation.
Change oil separator.

Maintenance Action					
	Every 8 Hours	Every 50 Hours	Every 1000 Hours	Every 2000 Hours	Every Year
Check/Change Air Filter					•
Check/Change Package Inlet Filters		•			
Change Oil Separator				•	
Check Reservoir Oil Level	•				
Check for Proper Load/Unload	•				
Change Oil Filter Element & Clean Oil Return Orifice				•	•
Change Compressor Lubricant (Nuair 546)				•	•
Check Relief Valve					•
Check Condition of Hoses					•
Check Operation of Condensate Removal Drain Valve	•				

INLET VALVE / VÁLVULA DE ENTRADA / SOUPAPE D'ADMISSION / VÁLVULA DE ADMISSÃO

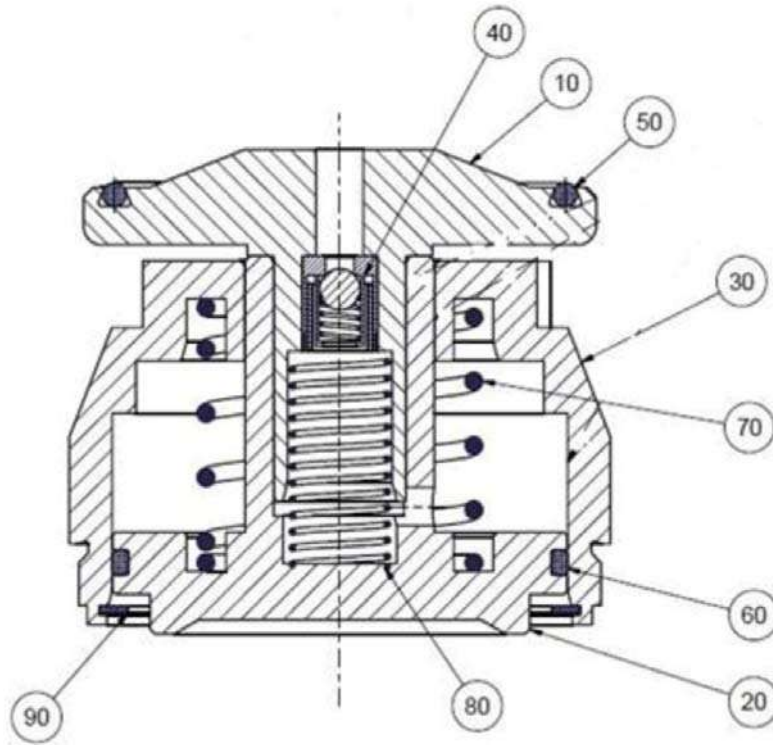

B/M: A11853074

REF. NO.	DESCRIPTION	DESCRIPCIÓN	LA DESCRIPTION	DESCRIÇÃO	QTY.	PART NO.
10	NON RETURN PISTON	PISTON NO DEVOLUCIÓN	PISTON NON RETOUR	PISTÃO NÃO DEVOLVER	1	A11853274
20	PISTON	PISTÓN	PISTON	PISTÃO	1	A11853374
30	CYLINDER	CILINDRO	CYLINDRE	CILINDRO	1	A11853474
40	NON RETURN VALVE	VÁLVULA DE RETENCIÓN	CLAPET ANTI-RETOUR	VÁLVULA DE NÃO RETORNO	1	A07715741
50	O-RING	O-RING	JOINT TORIQUE	O-RING	1	A93191210
60	O-RING	O-RING	JOINT TORIQUE	O-RING	1	A93191590
70	COMPRESSION SPRING	RESORTE DE COMPRESIÓN	RESSORT DE COMPRESSION	MOLA DE COMPRESSÃO	1	A93300530
80	COMPRESSION SPRING	RESORTE DE COMPRESIÓN	RESSORT DE COMPRESSION	MOLA DE COMPRESSÃO	1	A93300510
90	SPRING RING	ANILLO ELÁSTICO	RING RING	ANEL DE PRIMAVERA	1	A93148830

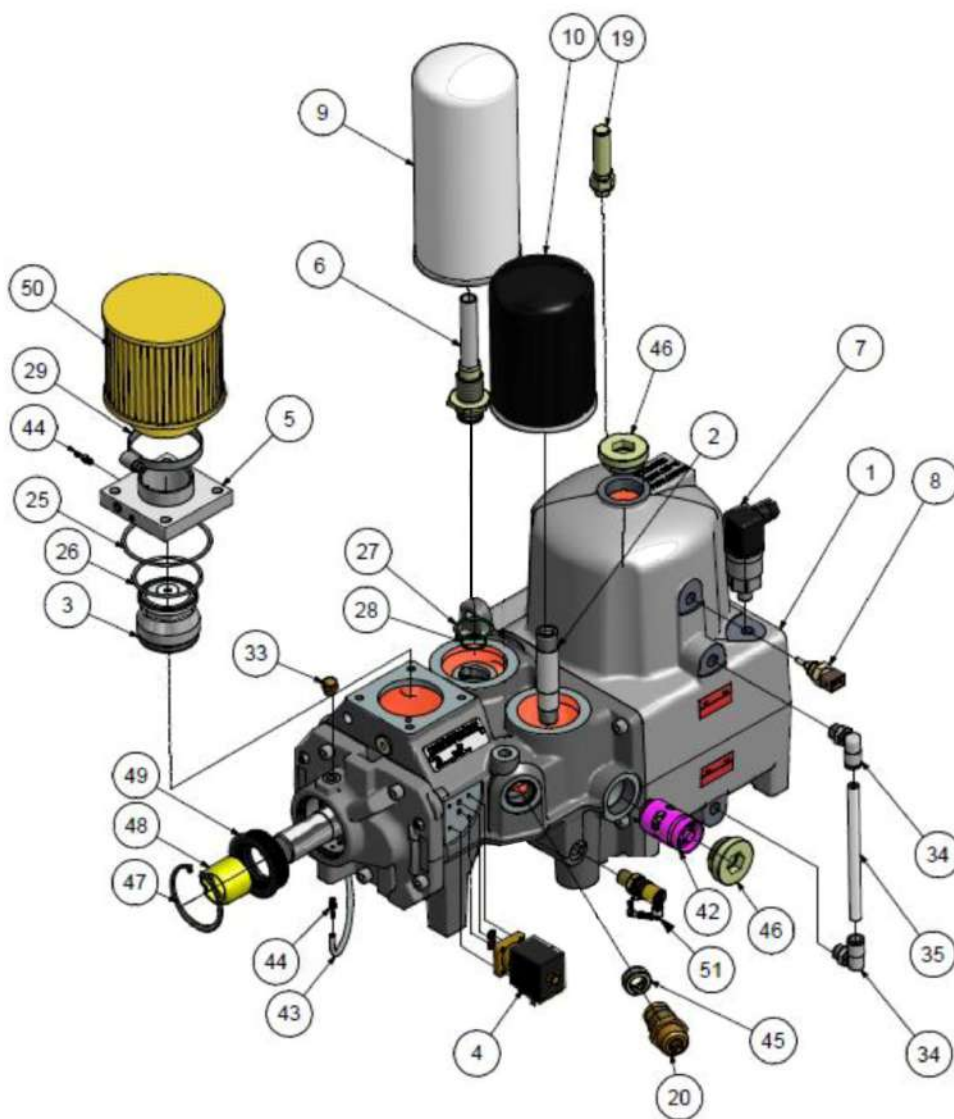

B/M 301KBA1095 • EK76

	DESCRIPTION	DESCRIPCIÓN	LA DESCRIPTION	DESCRIÇÃO	QTY.	PART NO.
1	AIREND EK76	AIREND EK76	AIREND EK76	AIREND EK76	1	A11850074
2	DOUBLE FITTING, OIL FILTER	AJUSTE DOBLE, FILTRO DE ACEITE	DOUBLE RACCORD FILTRE À HUILE	MONTAGEM DUPLA, FILTRO DE ÓLEO	1	ZS1060267
3	INTAKE CONTROLLER	Controlador de entrada	CONTRÔLEUR D'ADMISSION	CONTROLADOR DE ADMISSÃO	1	A11853074
4	SOLENOID VALVE	VÁLVULA DE SOLENOIDE	ELECTROVANNE	VÁLVULA SOLENOIDE	1	100015591
5	SUCTION FLANGE	BRIDA DE SUCCION	BRIDE D'ASPIRATION	FLANÇA DE SUCCÃO	1	ZS1047881
6	DOUBLE FITTING, SEPARATOR	AJUSTE DOBLE, SEPARADOR	DOUBLE FITTING, SEPARATOR	MONTAGEM DUPLA, SEPARADOR	1	ZS1060268
8	TEMPERATURE PROBE	PROBETA DE TEMPERATURA	SONDE DE TEMPÉRATURE	SONDA DE TEMPERATURA	1	103-012-S
9	AIR/OIL SEPARATOR	SEPARADOR DE AIRE/ACEITE	SEPARATEUR AIR / HUILE	SEPARADOR DE AR / ÓLEO	1	300KBA035
10	OIL FILTER	FILTRO DE ACEITE	FILTRE À L'HUILE	FILTRO DE ÓLEO	1	300KBA1446
19	PRESSURE RELIEF VALVE	VÁLVULA DE ALIVIO DE PRESIÓN	SOUPAPE DE LIMITATION DE PRESSION	VÁLVULA DE ALÍVIO DE PRESSÃO	1	100003009
20	MINIMUM PRESSURE VALVE	VÁLVULA DE PRESIÓN MÍNIMA	SOUPAPE DE PRESSION MINIMUM	VÁLVULA DE PRESSÃO MÍNIMA	1	ZS1046882
25	PIPE SEAL	SELLO DE TUBO	JOINT DE TUYAUTERIE	TUBO DE VEDAÇÃO	1	A93191640
26	PIPE SEAL	SELLO DE TUBO	JOINT DE TUYAUTERIE	TUBO DE VEDAÇÃO	1	A93191650
27	O-RING	O-RING	JOINT TORIQUE	O-RING	1	A93191630
28	O-RING	O-RING	JOINT TORIQUE	O-RING	1	A93191620
29	HOSE CLIP	ABRAZADERA	COLLIER DE SERRAGE	MANGUEIRA CLIP	1	A93610200
33	SILENCER	SILENCIADOR	SILENCIEUX	SILENCIADORA	1	A13012774

34	ELBOW	CODO	COUDE	COTOVELO	2	A93581670
35	TUBING (In Meters)	TUBERÍA (EN METROS)	TUYAUTERIE (EN MÈTRES)	TUBULAÇÃO (em metros)	.133	A91801060
42	THERMOSTATIC VALVE 70D C	VÁLVULA TERMOSTÁTICA 70D C	SOUPAPE THERMOSTATIQUE 70D C	VÁLVULA TERMOSTÁTICA 70D C	1	A11484474
43	PLASTIC HOSE (In Meters)	MANGUERA PLÁSTICA (EN METROS)	TUYAU EN PLASTIQUE (EN MÈTRES)	MANGUEIRA DE PLÁSTICO (EM METROS)	0.2	A93643260
44	FITTING	ADECUADO	RACCORD	APROPRIADO	2	A93601310
45	VALVE SEAT	ASIENTO DE VÁLVULA	SIÈGE DE SOUPAPE	ASSENTO DA VÁLVULA	1	A11852674
46	LOCKING SCREW	TORNILLO DE BLOQUEO	VIS DE VERROUILLAGE	PARAFUSO DE BLOQUEIO	2	A11852774
47	SNAP RING	ANILLO DE RETENCIÓN	SNAP RING	ANEL DE SNAP	1	A93147360
48	INTERNAL RING	ANILLO INTERNO	BAGUE INTERNE	ANEL INTERNO	1	100002517
49	SHAFT SEAL	SELLO DE CAÑÓN	JOINT D'ARBRE	VEDAÇÃO DO EIXO	1	A93220090
50	AIR FILTER	FILTRO DE AIRE	FILTRE À AIR	FILTRO DE AR	1	A11207674
51	OIL SAMPLING VALVE	VALVULA DE MUESTREO DE ACEITE	VANNE D'ÉCHANTILLONNAGE D'HUILE	VÁLVULA DE AMOSTRAGEM DE ÓLEO	1	86N345

Notes:

Intentionally left blank



Nuvair
Phone +1 805 815 4044
Fax +1 805 486 0900
1600 Beacon Place
Oxnard, CA 93033 USA
info@nuvair.com
www.nuvair.com