

70-100 Series

NPT Bronze Ball Valve



Job Name:	
Job Location:	
Engineer:	
Contractor:	
Tag:	
PO#:	
Rep:	
Wholesale Dist.:	

DESCRIPTION

The **Apollo® 70 Series** is the most widely used general purpose bronze ball valve on the market today. The 70-100 model is a 2-piece standard port* ball valve featuring female NPT connections. Cast and machined in Apollo's South Carolina manufacturing plants, these valves provide trusted performance and a wide range of options.

FEATURES

- Premium Materials and Heavy Duty Construction
- Adjustable Stem Packing Gland
- Blowout Proof Stem Design
- RPTFE Seats and MPTFE Stem Packing Rings
- Chromium Plated Ball
- 100% Factory Tested
- Wide Range of Options (see page 2)
- **Manufactured in the USA – ARRA Compliant**

MODELS

- 70-100 Series - Standard
- 70-140 Series - 316 SS Ball & Stem
- 70-190 Series - Pinned Retainer
- 70LF Series - Lead Free Option

APPROVALS

- MSS SP-110 - Ball Valves Threaded, Socket-Welding, Solder Joint, Grooved and Flared Ends
- CRN: OC10908.5C

STANDARD MATERIALS LIST

LEVER / GRIP	Steel, Zinc Plated w/ Vinyl
STEM PACKING	MPTFE
STEM BEARING	RPTFE
BALL	B16 or B283, C37700 Chrome Plated
SEAT (2)	RPTFE
RETAINER	B16 or B283, C37700 (1/4" to 1") B584-C84400 (1-1/4" to 4")
GLAND NUT	B16
STEM	B16
LEVER NUT	Steel, Zinc Plated
BODY SEAL (1-1/4"-4")	PTFE
BODY	B584-C84400

PERFORMANCE RATING

- CWP: 600 psi (41.37 Bar)
- SWP: 150 psi (10.34 Bar)
- Maximum Temperature: 500°F
- Vacuum Service to 29 in. Hg

DIMENSIONS

PART NUMBER	SIZE (IN.)	DIMENSIONS (IN.)					WT. (LB.)
		A	B	C	D	E	
70-101-01	1/4"	0.37	1.03	2.06	1.75	3.87	0.60
70-102-01	3/8"	0.37	1.03	2.06	1.75	3.87	0.56
70-103-01	1/2"	0.50	1.12	2.25	1.75	3.87	0.63
70-104-01	3/4"	0.68	1.50	3.00	2.12	4.87	1.39
70-105-01	1"	0.87	1.68	3.37	2.25	4.87	1.72
70-106-01	1-1/4"	1.00	2.00	4.00	2.62	5.50	3.26
70-107-01	1-1/2"	1.25	2.18	4.37	3.06	8.00	4.61
70-108-01	2"	1.50	2.34	4.68	3.25	8.00	6.06
70-109-01A	2-1/2"	2.00	3.12	6.25	3.72	8.00	13.96
70-100-01	3"	2.50	3.37	6.75	4.12	8.00	18.60
70-10A-01	4"	3.12	3.68	7.37	5.25	10.00	25.50

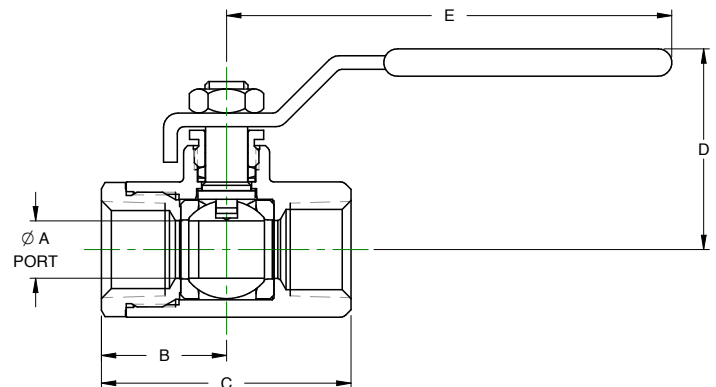

OPTIONS

- (-02) Stem Grounded 1/4" - 4"
- (-04) 2-1/4" CS Stem Extension 1/4" - 3"
- (-05) Plain Ball 1/4" - 3"
- (-07) Steel Tee Handle 1/4" - 2"
- (-08) 90° Reversed Stem 1/4" - 3"
- (-10) SS Lever & Nut 1/4" - 3"
- (-11) Therma-Seal™ Insulating Tee Handle 1/4" - 2"
- (-14) Side Vented Ball (Uni-Directional) 1/4" - 4"
- (-15) Wheel Handle, Steel 1/4" - 2"
- (-16) Chain Lever-Vertical 3/4" - 2"
- (-21) UHMWPE Trim (Non-PTFE) 1/4" - 3"
- (-24) Graphite Packing 1/4" - 3"
- (-27) SS Latch-Lock Lever & Nut 1/4" - 3"
- (-30) Cam-Lock & Grounded 1/4" - 2"
- (-32) SS Tee Handle & Nut 1/4" - 2"
- (-35) VTFE Trim 1/4" - 3"
- (-36) SS Hi-Rise Round Handle, SS Nut 1/4" - 2"
- (-39) SS Hi-Rise Locking Wheel Handle & Nut 1/4" - 2"
- (-40) Cyl-Loc & Grounded 1/4" - 2"
- (-41) Automatic Drain (Bronze Valves Only) 1/4" - 2"
- (-45) Less Lever & Nut 1/4" - 3"
- (-46) Latch Lock Lever-Lock Closed Position Only 1/4" - 3"
- (-47) SS Oval Latch-Lock Handle & Nut 1/4" - 1"
- (-48) SS Oval Handle (No Latch) & Nut 1/4" - 2"
- (-49) Assembled Dry 1/4" - 4"
- (-50) 2-1/4" CS Locking Stem Extension 1/4" - 3"
- (-56) MPTFE Seats and Packing 1/4" - 3"
- (-57) Oxygen Cleaned 1/4" - 4"
- (-58) Chain Lever-Horizontal 3/4" - 2"
- (-60) Static Grounded Ball & Stem 1/4" - 3"
- (-63) NPT x Solder 3/8" - 4"
- (-64) 250# Steam Trim 1/4" - 3"
- (-92) Balancing Stop 1/4" - 3"
- (-94) 2-1/4" Stem Extension & Balancing Stop 3/8" - 3"
- (-HC) Hose Thread w./ Cap & Chain 1/2" - 1"
- (-P01) BSPP (Parallel) Thread Connection 1/4" - 3"
- (-T01) BSPT (Tapered) Thread Connection 1/4" - 3"
- (-BC) Integral Check Cartridge (250psi max) 1/4" - 2"