



SDA
User Manual

Analox Ltd.
15 Ellerbeck Court, Stokesley Business Park
North Yorkshire, TS9 5PT, UK

T: +44 (0)1642 711400 **F:** +44 (0)1642 713900
W: www.analox.net **E:** info@analox.net

List of Contents

1	Introduction.....	2
1.1	Packing Overview	3
1.2	System Overviews	4
1.3	Monitor Controls Overview	9
2	Installation	10
2.1	Mounting	10
2.2	Monitor and Sensor Wiring	13
2.3	Output Module Wiring	16
2.4	Brackets	18
2.5	Pipe work	22
3	Operation.....	23
3.1	Start-up	23
3.2	Display	24
3.3	Sensor readings.....	25
3.4	Alarms.....	26
3.5	Calibration adjustment.....	30
3.6	Menu	32
3.7	Adjusting the backlight.....	33
3.8	Viewing device information.....	33
3.9	Data-logging	34
3.10	Serial data output.....	35
3.11	Output module	35
3.12	Power modes	36
3.13	Cell replacement reminder.....	37
4	Configuration	39
4.1	Software installation.....	39
4.2	Making a connection.....	40
4.3	Changing options.....	40
4.4	Downloading data logs	42
4.5	Setting the time	44
5	Troubleshooting.....	45
5.1	Fault conditions.....	45
5.2	Fault logging	45
5.3	Problems and actions	46
6	Maintenance	47
6.1	Oxygen cell replacement	47
6.2	Reconfiguring a unit.....	49
7	Spares and Accessories.....	50
8	Specifications	51
8.1	SDA Monitor	51
8.2	MEC Oxygen Sensor	51
8.3	Carbon Dioxide Sensor Module.....	52
8.4	SDA Output Module	52
9	Safety warnings.....	53
9.1	Oxygen Sensor – Caustic Electrolyte	53
9.2	Pressurised gas	54
9.3	Helium Ingress.....	54
9.4	ESD and Electric Shock.....	54
9.5	Servicing	54
9.6	IP Rating and General Care	54
9.7	Disposal	55
10	Warranty Information	56
11	Declarations of Conformity	58

1 Introduction

The SDA range is composed of a family of atmospheric analysis systems which are suitable for applications where continuous monitoring of atmospheres is required. Each type of system in the range will provide independent measurement and display of an atmospheric variable with clear audible and visual alarms to warn when potentially dangerous levels are reached.

The SDA range is designed to be highly modular and flexible so that it can be easily integrated into custom atmospheric monitoring solutions.

The core of each analyser is a compact monitor unit which provides the display and user interface for the system. A full colour 3.5" TFT display gives clear reading and status information and is suitable for a wide range of lighting and mounting positions. The controls present quick and simple access to the most common system functions such as calibration and alarm adjustment, with more detailed setup and diagnostic information accessed through an easy to use menu system.

The RS485 communication ports on the rear of a monitor provide connections to a range of Analox gas and environmental sensors and peripherals. These provide the flexibility to mount sensors and peripherals alongside the monitor or up to hundreds of metres away without affecting performance.

The SDA range is compliant with the type approval specifications from the major classification societies in the marine industry for both the general power distribution and bridge zones (refer to section 11 for more details).

1.1 Packing Overview

Oxygen system

- 1) Oxygen monitor (rack or panel mount)
- 2) MEC oxygen sensor
- 3) Push in flow adaptor
- 4) 2 way Phoenix connector (DC power)
- 5) 5 way Phoenix connector (sensor communications & power)
- 6) 5 way Phoenix connector (output module communications & power)
- 7) User manual
- 8) Test certificate

Carbon dioxide system (separates)

- 1) Carbon dioxide monitor (rack or panel mount)
- 2) Carbon dioxide sensor module (rack or panel mount)
- 3) 2 way Phoenix connector (DC power)
- 4) 5 way Phoenix connector (sensor communications & power)
- 5) 5 way Phoenix connector (output module communications & power)
- 6) User manual
- 7) Test certificate

Carbon dioxide system (combined panel mount)

- 1) Combined carbon dioxide monitor and sensor module
- 2) 2 way Phoenix connector (DC power)
- 3) 5 way Phoenix connector (sensor communications & power)
- 4) 5 way Phoenix connector (output module communications & power)
- 5) User manual
- 6) Test certificate

Accessories (optional)

- 1) AC-DC +24VDC panel mounted power supply unit (PSU)
- 2) MEC Oxygen sensor only mounting plate
- 3) Combined mounting plate (PSU, SDA Output module and MEC Oxygen sensor)
- 4) SDA Output module (bracket / panel mount)
- 5) SDA Flow meter plate (rack or panel mount)

1.2 System Overviews

1.2.1 SDA O₂

There are two types of oxygen monitoring system arrangement based on a SDA Monitor and MEC O₂ sensor, depending on which monitoring application is required. The MEC O₂ sensor is designed to operate in either atmospheric or hyperbaric environments, to depths of 350 msw.

The atmospheric version of the sensor is ranged to 100% O₂ and has inbuilt pressure compensation which will automatically adjust to changes in the ambient atmospheric pressure. This enables accurate measurement and adjustment when operating in atmospheres between 700 mbara and 1300 mbara. When fitted with a flow adaptor, as shown in the figure below, the 100% O₂ version of the sensor can monitor a sample line from a remote source or chamber (refer to section 2.5 for pipe work detail). When used without a flow adaptor the MEC O₂ sensor will measure oxygen in the surrounding ambient atmosphere diffusing across the sensor membrane.

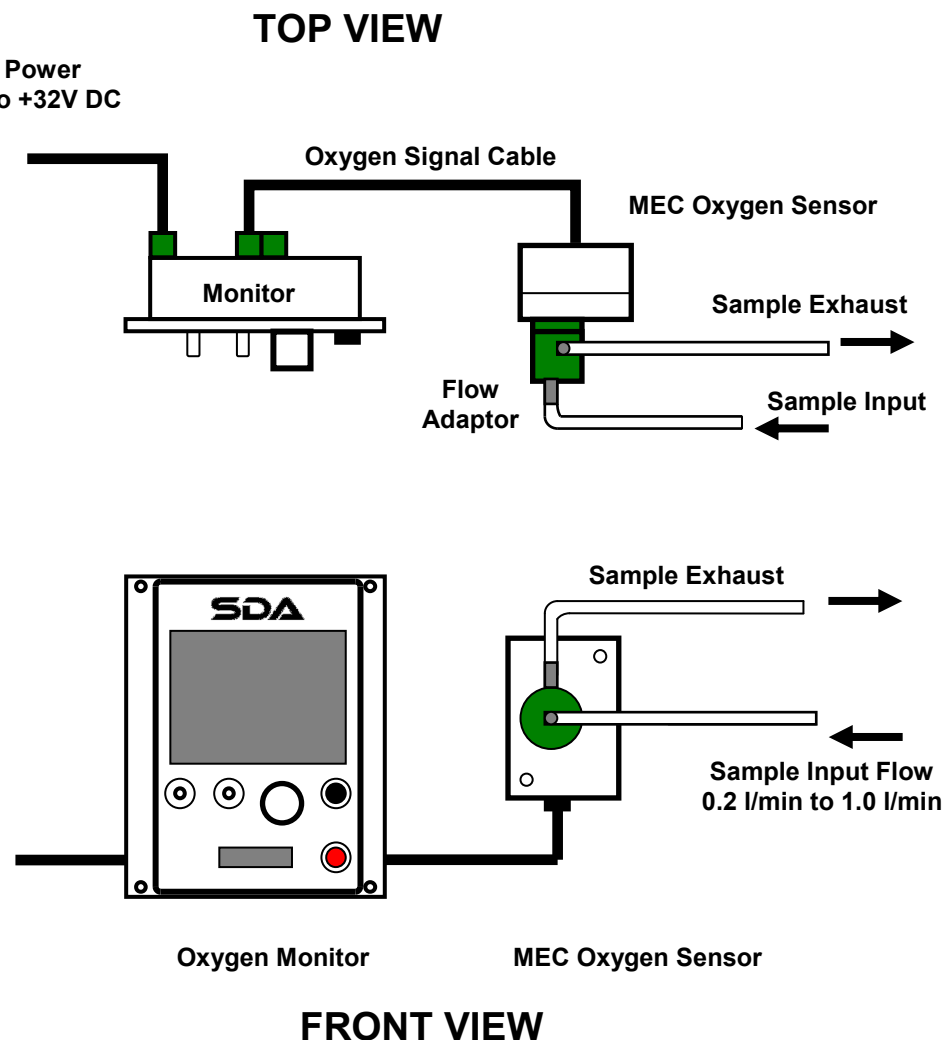

Figure 1 - SDA oxygen system overview

Warning: Ensure that when used with a flow adaptor that sample pressure is reduced down to almost atmospheric pressure before passing to the sensor. This will prevent potential damage to the sensor and affects that can cause elevated sensor readings. A flow rate between 0.2 and 1.0 l/min is acceptable, 0.5 l/min is recommended.

The sensor comes with a 150mm cable and will fit the either of the two mounting bracket accessories (see section 1.2.3). These can be used on both rack and panel mounting versions of the system. Where longer cable distances are required the connection can be extended replacing the connector on the short cable with a terminal block or by replacing the cable from the internal MEC connector block. A cable of 2 twisted pairs with an outer shield is required to maintain communication integrity, enabling distances up to 500m to be achieved between the monitor and sensor.

The hyperbaric version of the sensor will measure partial pressures up to 3000 mbar O₂ and operate in pressures up to 36 bara. In this application a longer cable must be fitted to provide the connection to the monitor, which remains outside of the hyperbaric atmosphere (see figure below).

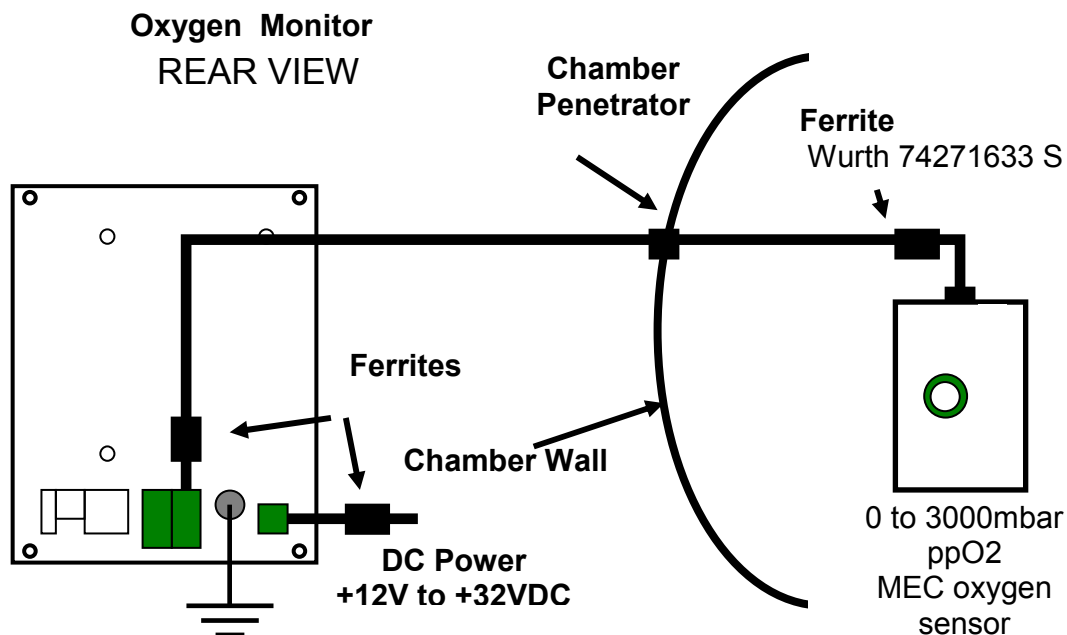

Figure 2 – Sensor inside a saturation dive chamber

Warning: Long signal and power cables can increase EMC emissions and be more susceptible to EMC interference. For power and signal cable lengths greater than 1.5 metres, signal ferrites are recommended to be fitted (see above).

1.2.2 SDA CO₂

The SDA CO₂ is composed of a SDA Monitor and a CO₂ module with a 220mm signal cable. The module contains the carbon dioxide sensor and is designed to fit alongside the monitor in a rack or panel (depending on which type is supplied). Where longer distances are required between the CO₂ module and the monitor, the cable connection can be extended with the use of a terminal block with a cable of 2 twisted pairs with an outer shield.

The sample lines are compatible with 6mm OD, 4mm ID flexible tubing. The input sample passes through the flow meter first and can take a maximum input pressure of 6 bara.

Warning: The flow must be regulated on the flow meter to be greater than 0.2 l/min and less than 1.0 l/min, a flow of 0.5 l/min is recommended. When both SDA O₂ and SDA CO₂ systems are fitted in the same rack or panel, the exhaust line from the CO₂ system may be connected to input of the O₂ flow adaptor to if it is required to monitor the same sample line.

See section 2.5.2 for fitting details.

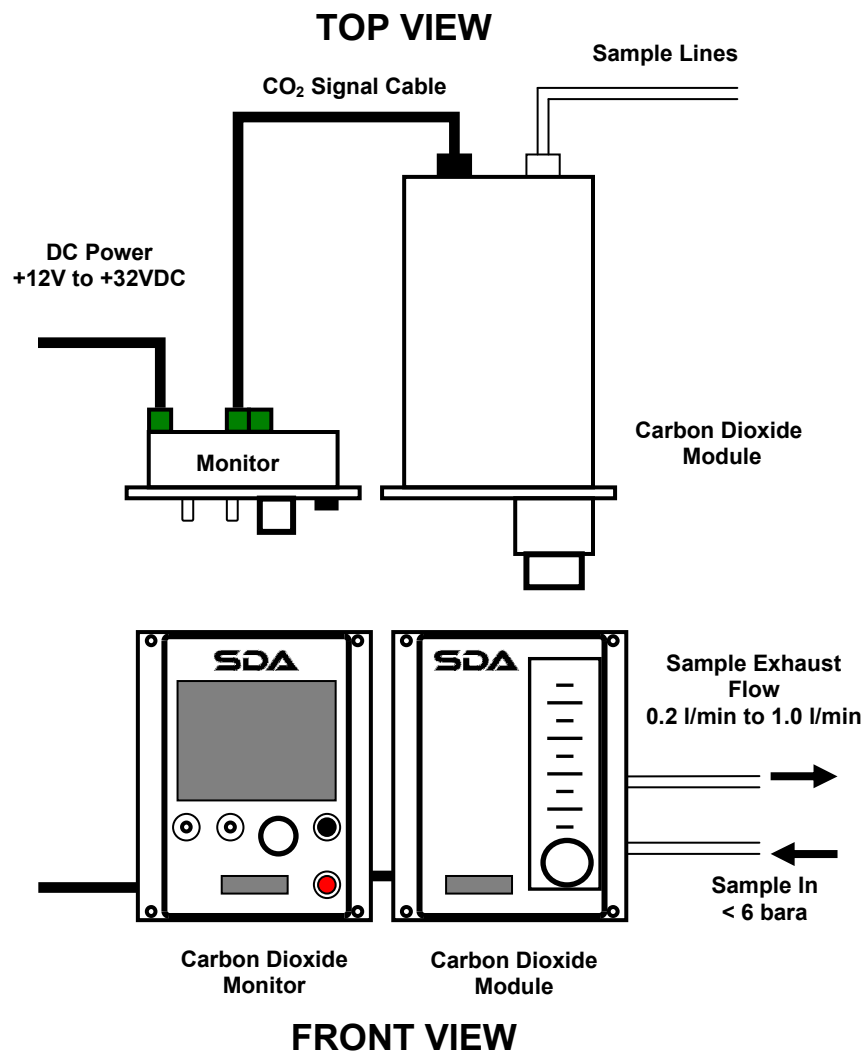

Figure 3 - SDA carbon dioxide system overview

1.2.3 Mounting Plate Accessories

Two brackets may be used to mount the MEC Oxygen sensor to SDA Monitor. If a power supply or SDA Output Module is required the combined bracket can be fitted. Refer to section 2.4 for more detail.

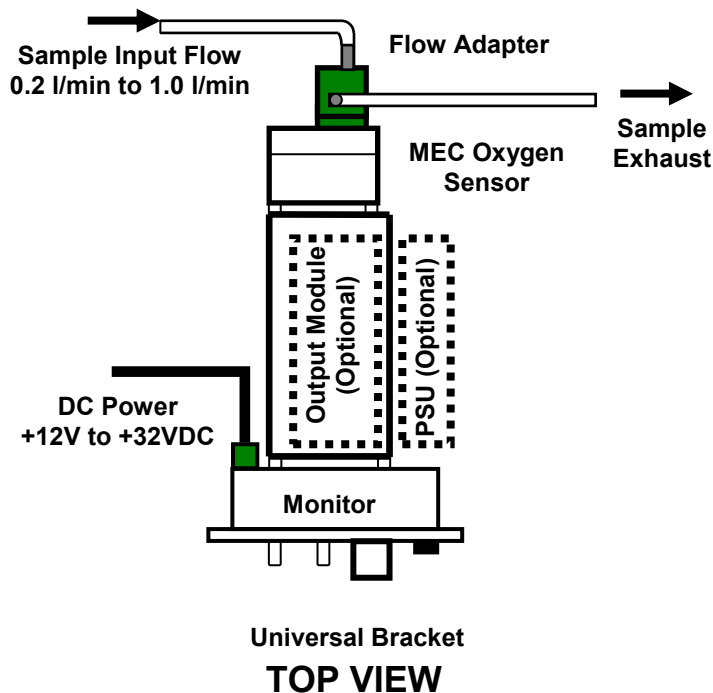
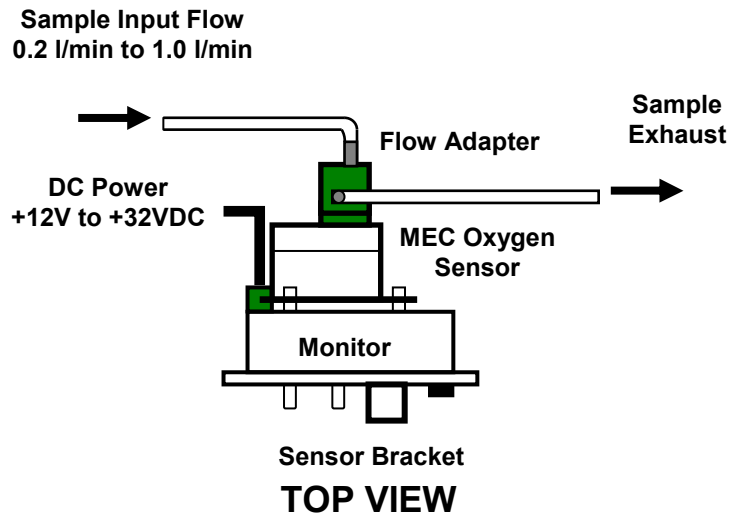

Figure 4 - Mounting plates and accessories overview

1.2.4 Operation in the Bridge Zone

The SDA systems meets EMC requirements for the general power distribution zones defined in type approval specifications for Lloyd's Register, DNV and ABS classification societies. To fit into the bridge zone a filter must be fitted to comply with rules on radio interference, as shown below to the DC supply. Refer to section 2 for detailed system wiring.

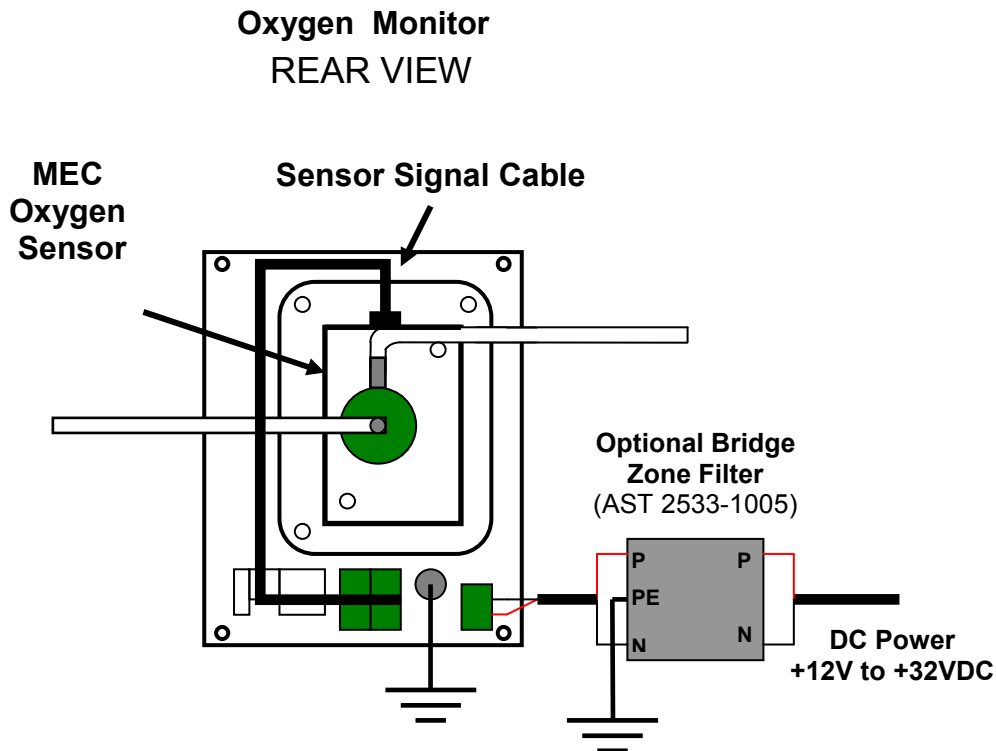

Figure 5 - Bridge distribution zone

1.3 Monitor Controls Overview

Figure 6 shows an overview of the controls located on the front panel of an SDA.



Figure 6 - SDA front panel overview

- 1) Colour TFT LCD display
- 2) Adjustment knob
- 3) Calibration adjustment toggle switch
- 4) Set button
- 5) Alarm adjustment toggle switch
- 6) Mute button

2 Installation

Please observe the safety information in section 9 before installation.

2.1 Mounting

2.1.1 Rack Mounting

Rack versions are designed to be mounted onto standard 19" mounting rails. The systems are 3U high and 21hp wide so 4 modules will occupy the full width of the standard 84hp wide 19" rail.

2.1.2 Panel Mounting

Panel versions are suitable for direct mounting into instrument panels and they will fit the same apertures used by the older series of Analox 1000 and 5001 analysers. The cut-out aperture should measure as follows:

- Height - 112mm
- Width - 102mm

Mounting centres for panel mount variants should be as follows:

- Holes - 4 x 6mm
- Height - 122.5mm
- Width - 91.4mm
- Centred - On cut out

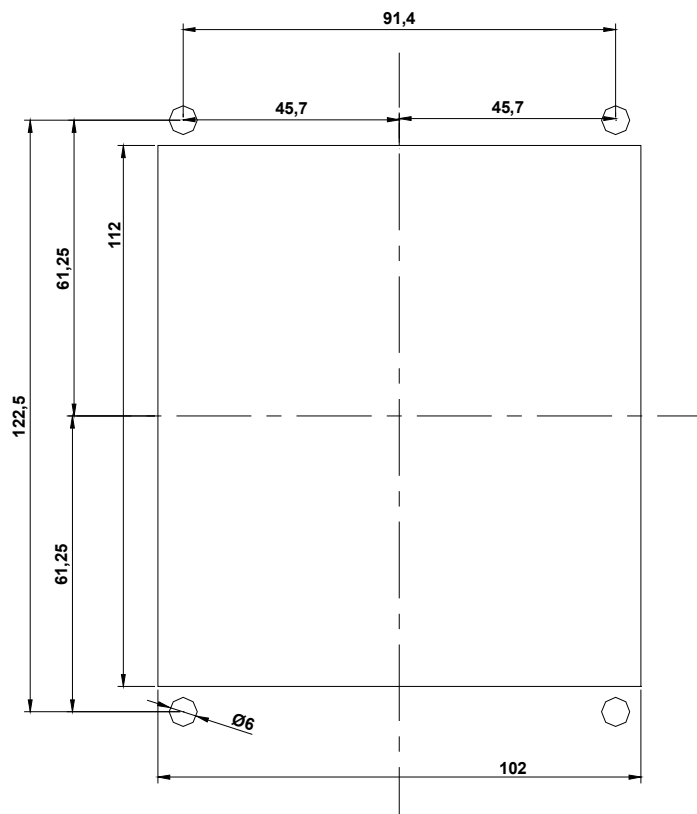
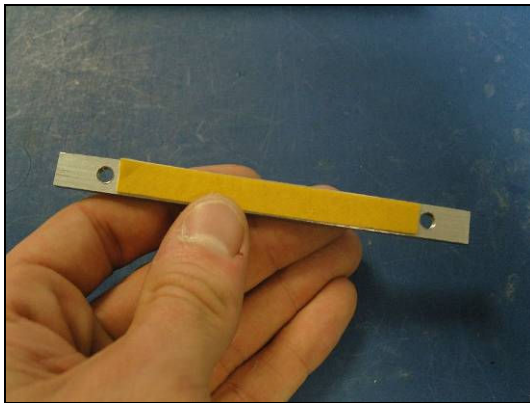
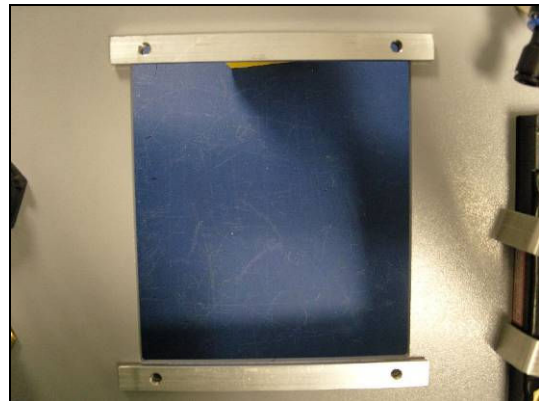

Figure 7 - Panel mounting holes

2.1.3 Panel Mounting Procedure



- 1) To mount the panel variant instrument, take the two supplied brackets and remove the backing from the adhesive foam.



- 2) Place the brackets behind the panel and align the M5 holes with the 6mm holes in the panel, adhere the brackets to the rear of the panel with the adhesive foam.



- 3) Align the instrument up to the panel and secure in place with the four provided M5x25mm Pozi-Pan screws.

2.1.4 The Combined Panel Adaptor Mounting Procedure

A combined panel mount adaptor plate kit (XK0-445K) is also available as an accessory to mount a rack mount CO₂ variant into an existing combined panel cut out.

This can be mounted to the panel as per the steps below.

- 1) Remove the rack mount fixings from the monitor and CO₂ module
- 2) Place the monitor into the adaptor plate (left hand side) and align with the four tapped M3 holes
- 3) Secure the monitor in place with four of the provided M3x8mm Pozi-Pan screws and M3 Nordlock washers
- 4) Place the CO₂ module through the remaining space and align with the remaining four tapped M3 holes
- 5) Secure in place with the remaining four M3x8mm Pozi-Pan screws and M3 Nordlock washers
- 6) Finally, secure the assembly into your panel using the provided M5x25mm Pozi-Pan screws and M5 captive nuts.

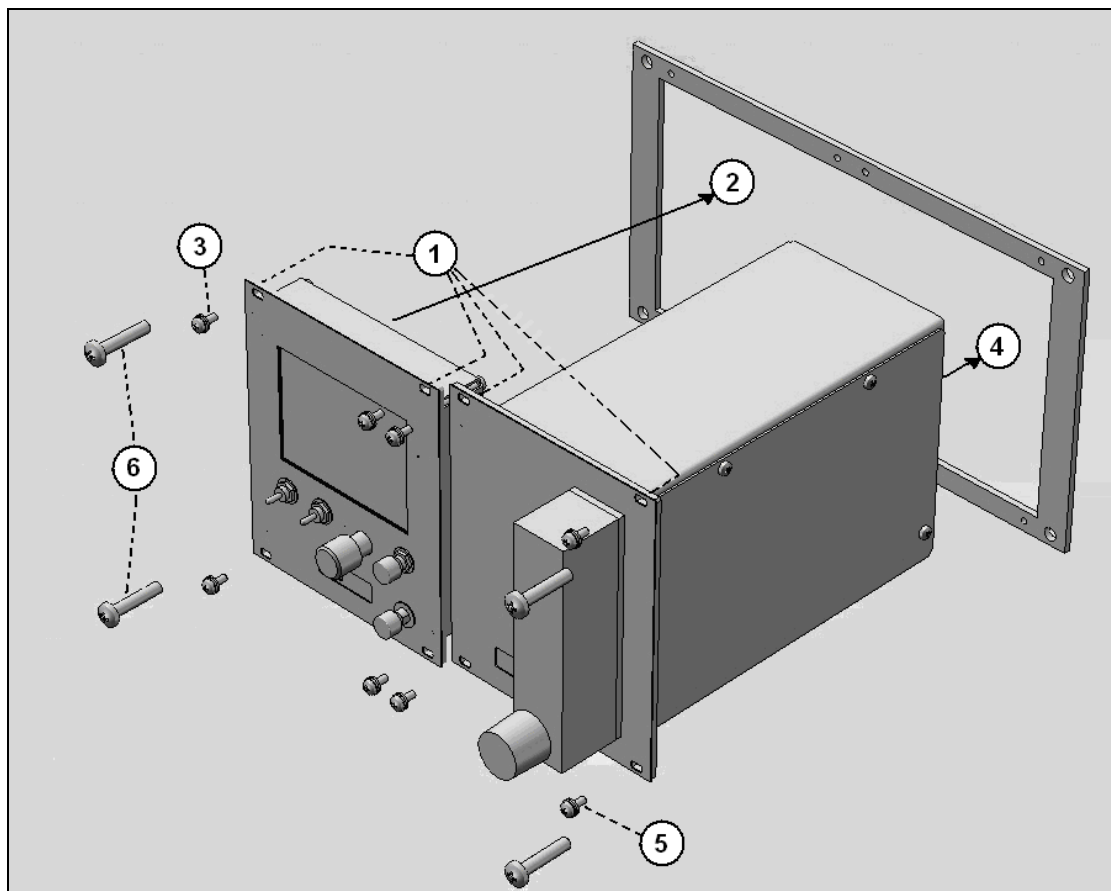

Figure 8 – Building the combined panel

2.2 Monitor and Sensor Wiring

Warning: Long signal and power cables can increase EMC emissions and be more susceptible to EMC interference. For power and signal cable lengths greater than 1.5 metres signal ferrites are recommended to be clipped onto the cable (see section 1.2.1).

2.2.1 Monitor Connectors Overview

The SDA Monitor provides the connectors for all the system interconnections at the rear of the unit as shown in the figure below.

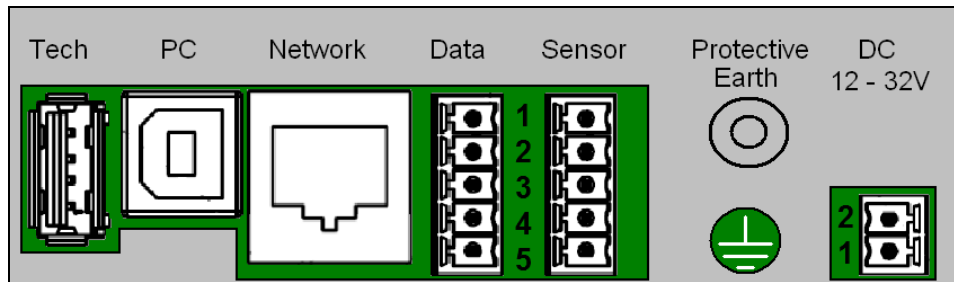

Figure 9 - SDA monitor rear connectors

PC Communication

Connector	Description
Tech - USB Type A socket	Reserved
PC - USB Type B socket	USB connection to a PC. Used for configuration and downloading historic data (optional).
Network - RJ45 socket	Reserved

Sensor and Peripheral Connectors

Connector	Pin	Function	Comments
Monitor Data Phoenix MVC 5 way (3.5mm pitch)	1	V+	+5V DC supply output used to power the SDA Output Module (max 390mA).
	2	RS485 A	Differential TxD-/RxD- aka inverting pin
	3	RS485 B	Differential TxD+/RxD+ aka non-inverting pin
	4	RS485 Ref	Common reference signal to connect to remote RS485 device. If not required it should be looped back to pin 5 (0V).
	5	V-	0V DC connection for the supply output
Monitor Sensor Phoenix MVC 5 way (3.5mm pitch)	1	V+	+5V DC supply output used to power an SDA sensor (max 390mA).
	2	RS485 A	Differential TxD-/RxD- aka inverting pin
	3	RS485 B	Differential TxD+/RxD+ aka non-inverting pin
	4	RS485 Ref	Common reference signal to connect to remote RS485 device. If not required it should be looped back to pin 5 (0V).
	5	V-	0V DC connection for the supply output
Protective Earth	M4 Stud	Chassis Earth	Connects the system casework to the local protective earth. Sensor cable shields are also connected here.
Monitor Power Phoenix MVC 2 way (3.5mm pitch)	1	Vin+	Supply input +12 V DC to +32 V DC. (15 W maximum, 3 W typical)
	2	Vin-	Supply input 0V DC

2.2.2 The Power Connection

The monitor can be directly powered from a DC source, using the supplied two way Phoenix connector as shown in the steps below.



1) Supplied DC connector

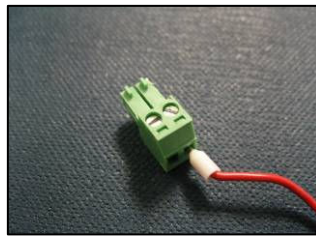

2) Connect +VE

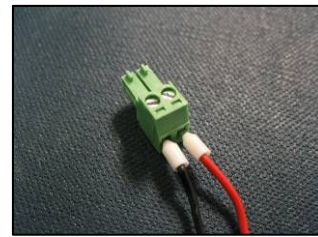

3) Connect 0V

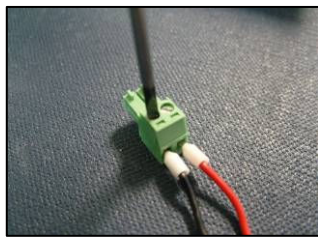

4) Secure using a terminal driver

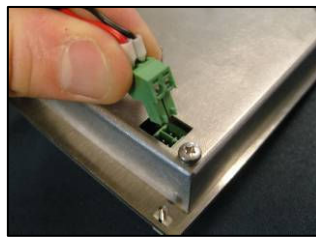

5) Connect to the DC input on the rear of the monitor

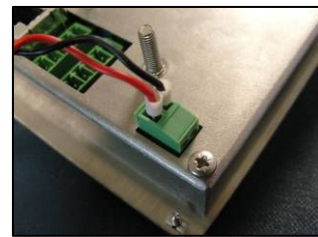

The monitor can also be powered from an AC source. The AC adaptor (XK0-662) can be purchased as an accessory from Analox, this will connect directly into the DC input on the rear of the monitor. This can be mounted in a location of your choice or to the combined mounting bracket (XK0-472K) as detailed in section 2.4

2.2.3 Protective Earth

Warning: The M4 stud next to the power connection must be connected to the local protective earth to provide ESD and surge protection. This stud also provides the shield connection to the sensor and data port cables and is required to maintain EMC performance.

2.2.4 Sensor and Data Wiring

The Sensor connector provides the power and communication link to any SDA sensor attached. The Data connector will automatically control the SDA Output module if attached otherwise this port will revert to a continuous data output stream that can be utilised by other third party equipment for data logging purposes. See section 3.10 for detail on connection baud rate and data formats.

The wiring for both sensor and output module follow the arrangement in the figure below:

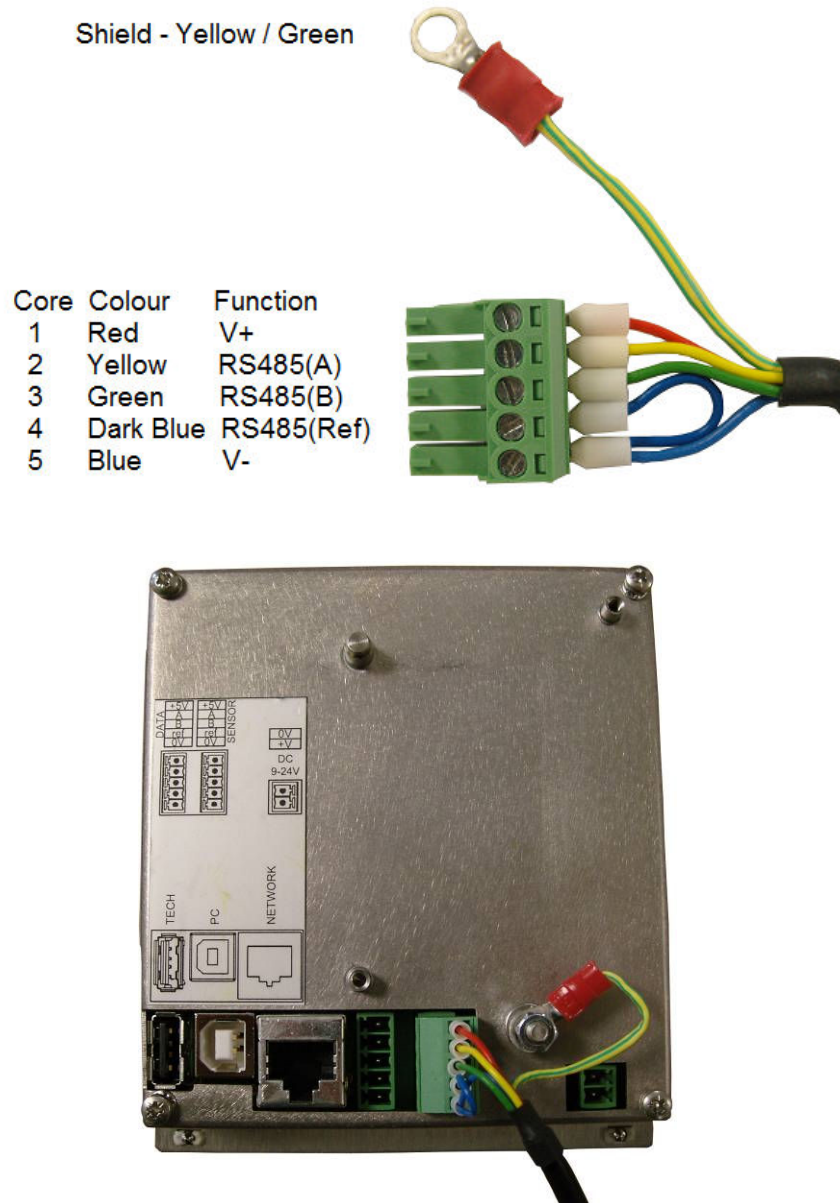

Figure 10 - Sensor wiring

2.3 Output Module Wiring

The SDA output module can be connected to the Data port on the SDA Monitor to provide an analogue output of the sensor reading and the status of the alarms on the volt free contact relays.

2.3.1 Output Module Connections Overview

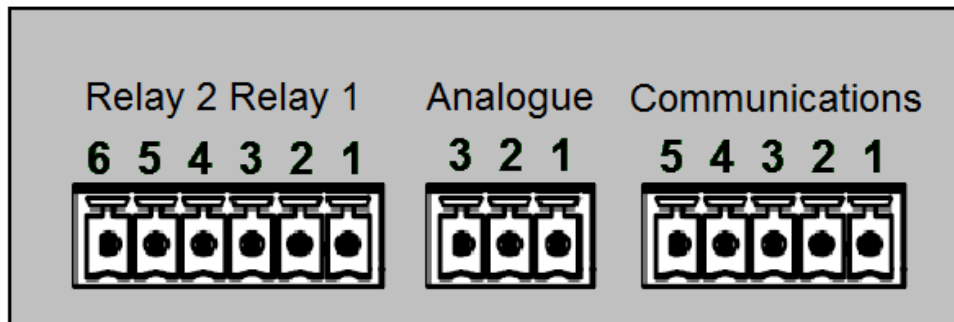

Figure 11 - SDA output module connectors

Connector	Pin	Function	Comments
Communications Phoenix 5 way (3.5mm pitch)	1	V+	+5V DC supply input used to power the SDA Output Module (max 300mA).
	2	RS485 A	Differential TxD-/RxD- aka inverting pin
	3	RS485 B	Differential TxD+/RxD+ aka non-inverting pin
	4	RS485 Ref	Common reference signal to connect to SDA Monitor (not used).
	5	V-	0V DC connection for the supply output
Analogue Phoenix 3 way (3.5mm pitch)	1	Sink-	Passive analogue current connection
	2	Com	Common analogue current connection
	3	+Src	Active analogue current connection
Relays Phoenix 6 way (3.5mm pitch)	1	NC	Relay 1 Normally Closed (NC) contact
	2	COM	Relay 1 common
	3	NO	Relay 1 Normally Open (NO) contact
	4	NC	Relay 2 Normally Closed (NC) contact
	5	COM	Relay 2 common
	6	NO	Relay 2 Normally Open (NO) contact

2.3.2 Analogue Output

The analogue output may be configured by wiring to either the current sink (passive) or to the current source (active). When configured as an active source the default drive voltage is nominally +13V DC.

By use of a suitable load resistor with the active source connection, the unit may provide a voltage output with full scale output configurable to over +12V DC depending on the value of the resistor used. For 0-1V output, the resistor would be 50R, for 0-2V use 100R etc.

If an external current source is used, the unit should be wired as a current sink using pins 1 and 2, with the negative of the external source connected to pin 1. The drive voltage of the external source should be no more than 48V due to the overvoltage protection diodes, but the unit only requires a compliance voltage of less than 1V to properly control the output current.

If an external current sink is used (e.g., a simple analogue meter), the unit should be wired as a current source using pins 2 and 3. In this case, the positive of the source is on pin 3. The resistance of the external sink must be considered; as standard the unit is configured to drive an external resistance up to at least 550R (greater than 12V compliance voltage).

2.3.3 Relay Outputs

There are two identical controllable relay outputs with a single change-over contact each, with the COM (common) line connected to either NO (normally open) or NC (normally closed).

For true failsafe the NO-COM contact pair can be used to indicate an OK state when closed, so that disconnections or open circuit cable faults will provide the fault state.

For details of the operational states of the relays when connected to an SDA see section 3.11.2.

2.4 Brackets

There are two brackets available for the SDA, one for only mounting the MEC oxygen sensor, the other will fit the sensor, power supply and output module as required.

2.4.1 Fitting the oxygen-only bracket

The oxygen only bracket (XK0-473K) is suitable for mounting the MEC oxygen sensor to the rear of the monitor. The MEC oxygen sensor must be fitted to the bracket before fitting the bracket to the rear of the monitor. This is detailed in the steps below.



1) Bracket kit (XK0-

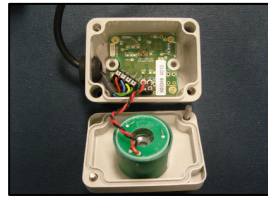

2) Remove MEC lid

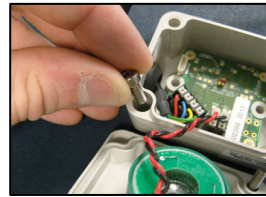

3) Insert M4 screw



4) Replace MEC lid



5) Secure with 3mm Hex key & M4 Nyloc nuts



6) Finished assembly

The bracket and the MEC oxygen sensor can then be attached to the rear of the monitor as per the steps below.

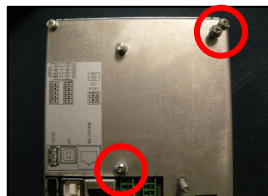

7) Remove 2 x M3 x 6mm Pozi Pan Screws and Nordlock washers from rear of monitor



8) Align mounting hole with standoff



9) Secure bracket with 2 x M3 x 6mm Pozi-Pan Screws and Nordlock washers

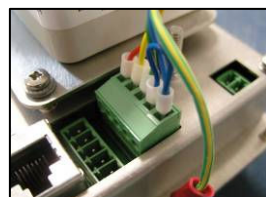

10) Connect MEC oxygen sensor



11) Connect MEC oxygen sensor earth to earth stud

2.4.2 Fitting the combined oxygen and power supply mounting bracket

The combined oxygen and power supply bracket (XK0-472K), can be used to mount the optional AC power supply, MEC oxygen sensor and/or an output module. Mount the bracket to the monitor follow the steps below.



1) Remove 2 x M3 x 6mm Pozi Pan Screws and Nordlock washers from rear of monitor



2) Align mounting hole with standoff

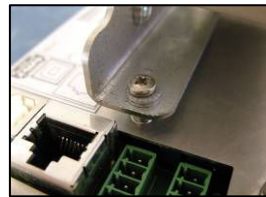

3) Secure in place with the 2 x M3 x 6mm Pozi Pan Screws and Nordlock washers from rear of monitor

2.4.3 Fitting the MEC oxygen sensor to the rear of the bracket

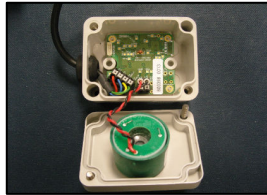

1) Remove lid from MEC



2) Insert the supplied M4 cap screws into each mounting hole



3) Replace MEC lid



4) Align M4 cap Screws with standoffs



5) Tighten the M4 cap Screws with a 3mm hex key

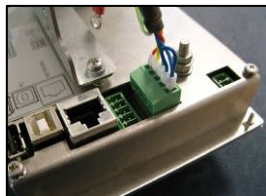

6) Connect the MEC oxygen sensor



7) Connect MEC oxygen sensor earth to earth stud

2.4.4 Fitting the SDA output module to the bracket



1) Remove lid from output module

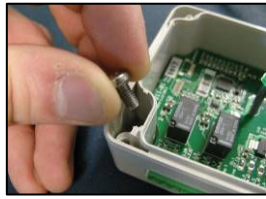

2) Insert the supplied M4 x 8mm Pozi-Pan Screws into each mounting hole

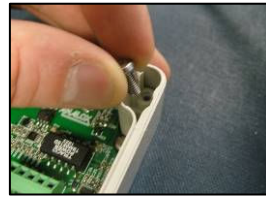

3) Align screws with standoffs



4) Tighten the M4 Pozi Pan screws



5) Replace lid on output module



6) Connect output module cable

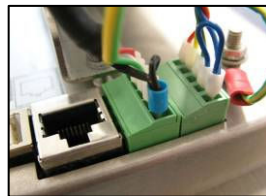

7) Connect output module earth to earth

2.4.5 Fitting the external DC adaptor



1) Align the PSU mounting holes with the four outer M4 threaded inserts on the bracket



2) Secure in place with the supplied M4 x 8mm Pozi Pan screws

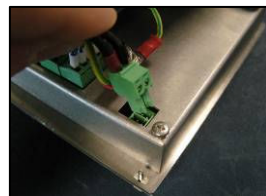

3) Connect to the DC input on the rear of the monitor



2.4.6 Completed assembly of combined oxygen and power supply mounting bracket

Figure 12 shows an overview of the combined bracket fitted with the MEC oxygen sensor, AC power supply and SDA output module.



Figure 12 - Assembly with the combined mounting bracket

- 1) MEC oxygen sensor
- 2) Bracket
- 3) Optional AC power supply
- 4) Optional output module

2.5 Pipe work

Warning: Exhaust lines can produce back pressure at the sensor which will affect the sensor reading. Keep this line as short as possible, e.g. less than 150 mm. It is acceptable to use no exhaust tube if it is appropriate for the type of sample gas. The pressure of the sample gas must be close to the ambient pressure otherwise damage may occur to the sensors and sensor accuracies will be affected. The inlet flow rate to the sensors must be between 0.2 to 1.0 l/min, 0.5 l/min is recommended. When SDA flow meters are used the input pressures to the meter must not exceed 6 bara.

2.5.1 MEC oxygen sensor pipe work

The MEC oxygen sensor is supplied with a two port flow adaptor. The tubing should be trimmed to the correct length then the flow adaptor removed to fit the tubing onto the spigots.

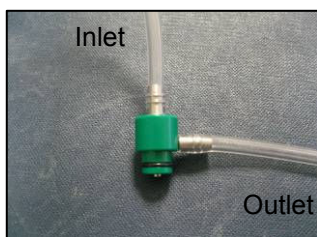

1) Connect pipe work to flow adaptor



2) Connect flow adaptor to the inlet of the MEC O2 sensor



The MEC oxygen sensor sample input line can also be piped to a dedicated SDA flow adaptor unit or connected to the exhaust of the SDA CO₂ sensor module.

2.5.2 Carbon dioxide sensor module pipe work

The CO₂ sensor module should be connected as per the following steps.



1) Remove bulkhead pipe securing nuts



2) Fit securing nuts to pipes



3) Fit Gas Input and Exhaust pipe-work to bulkheads



4) Secure pipe work in place with securing nuts



5) Finished connections

3 Operation

3.1 Start-up

An SDA will automatically start up when power is supplied to it. Initially, the SDA will display a splash screen which will be displayed for a few seconds after which the display will go blank for up to 15 seconds. The SDA will then show the main display as described in section 3.2.1.

Upon start-up, an attached sensor may require a short time to warm up as described in section 3.3.2.



Figure 13 - Start-up splash screen

3.2 Display

3.2.1 Main display screen

Under normal operation the SDA will display its main display screen. Figure 14 explains the elements of the main screen.

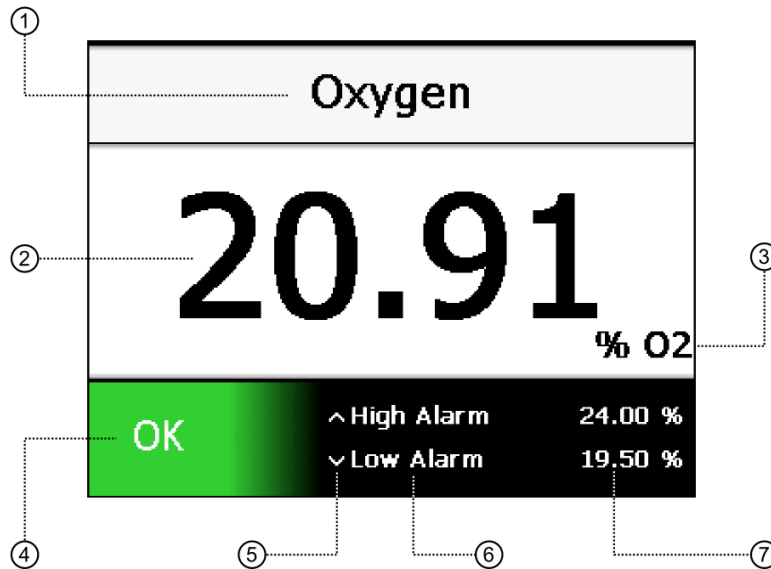

Figure 14 - Main display overview

- 1) Device identification label
- 2) Live sensor reading
- 3) Sensor type and display units
- 4) System status indicator
- 5) Alarm direction indicators
- 6) Alarm names
- 7) Alarm set-points

3.2.2 System status indicator

The system status indicator shows the current status of the SDA system. If any alarm condition has been identified then the system status indicator will turn red and display the word 'Alarm'. If any system fault is identified then the status indicator will turn yellow and display the word 'Fault'. In no current alarm or fault conditions have been identified then the system status indicator will turn green and display the word 'OK'. Figure 15 shows the different system status indicator states.



Figure 15 - System status indicator

3.2.3 Device identification label

At the top of the main display screen is the device identification label. By default this label indicates the type of SDA as shown in Figure 16. An SDA can be configured using the SDA software to display a custom identification label. This can be used to help identify individual units in a large panel. Figure 17 shows an example of a custom identification label. For instructions on how to configure the identification label see section 4.3.1.

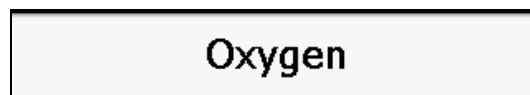

Figure 16 - Default device identification label for an SDA - O₂

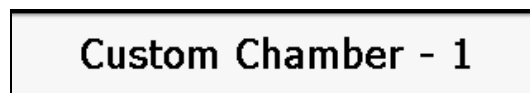

Figure 17 - Example of a custom identification label

3.3 Sensor readings

3.3.1 Sensor reading update

When a sensor is attached to an SDA a live reading from the sensor will be displayed in the centre of the main display. This reading will be updated on the display once per second. If no valid sensor reading is currently available then three dashes ('---') will be shown instead.

3.3.2 Sensor warm-up

Under certain circumstances, when the digital sensor attached to the SDA cannot display a valid reading then the display will show that the sensor is in a warm-up state. Warm-up occurs when the SDA is initially powered up and may last 10 to 60 seconds depending on the sensor type attached. Under certain circumstances the sensor may enter a warm-up state whilst it processes information such as after a calibration adjustment has been attempted or when a sensor is re-connected after being disconnected. Whilst in a warm-up state, the display reading is shown as three dashes ('---') and a warm-up processing animation is displayed (Figure 18).

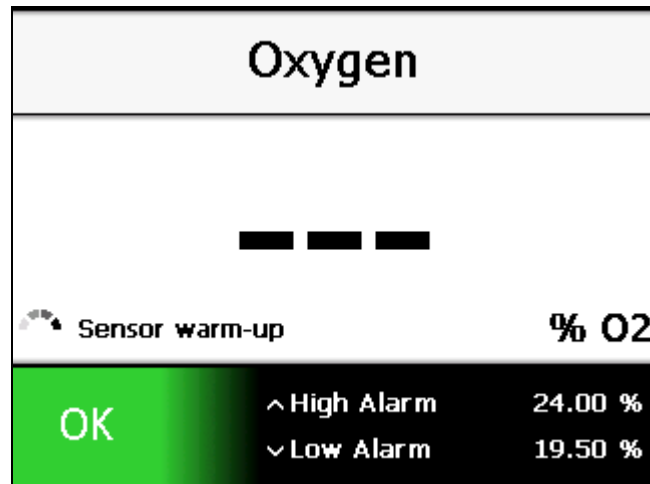

Figure 18 - Example of a sensor that is in a warm-up state

3.4 Alarms

Each SDA comes with two alarms defined. Each alarm is defined by a set-point and a direction. The name, set-point and direction of both alarms are shown on the main display screen as shown in Figure 14. Every second, as the sensor reading is updated, each alarm is checked against the current reading. For high-going direction alarms, an alarm condition will be triggered if the sensor reading is greater than the alarm set-point. Conversely, for low-going direction alarms, an alarm condition will be triggered if the sensor reading is less than the alarm set-point.

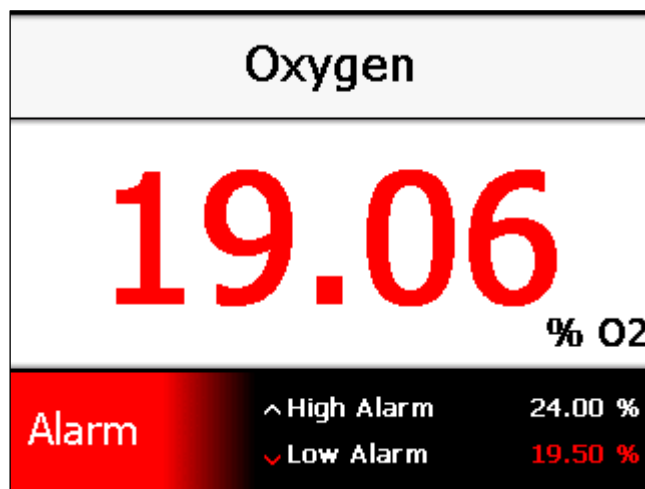

Figure 19 - A low-going alarm that has been triggered

When an alarm condition is identified the horn will immediately sound and the system status indicator will flash, coloured red, showing the word 'alarm'. In addition the sensor reading will be displayed, coloured red, and the set-point for the alarm that has been triggered will be highlighted. Figure 19 shows an example of a low-going alarm that has been triggered by a low oxygen reading.

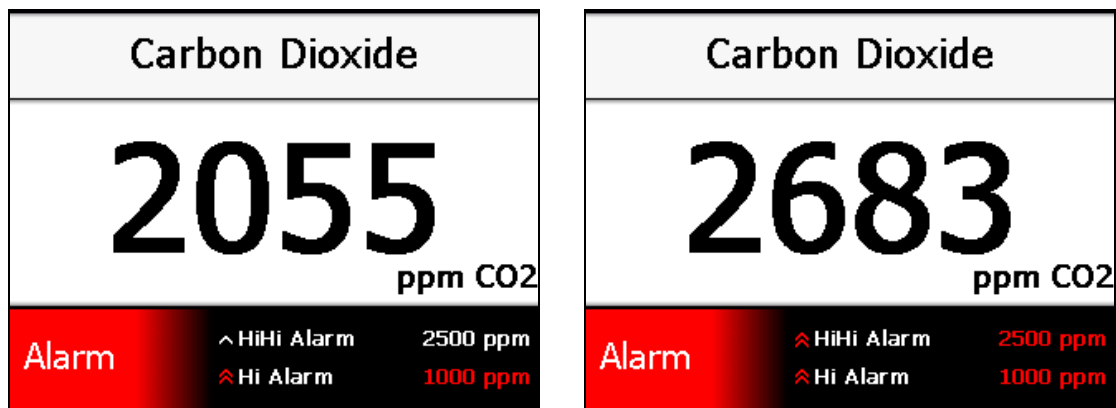

Figure 20 - Example of two high-going alarms

In cases where two alarms with the same direction are defined, the horn and alarm status will be triggered when the first alarm condition is met. If the sensor reading continues in the same direction and the second alarm condition is met then both alarm conditions will be shown as triggered. Figure 20 shows an example of two high-going carbon dioxide alarms.

If the first alarm is triggered and the horn is subsequently muted, the horn will be re-activated if the second alarm is triggered.

3.4.1 Muting alarms

When an alarm condition is triggered and the horn sounds, the horn can be muted by pressing the red mute button. This will mute the horn in all occasions where the horn is activated. In addition, when an alarm is muted, the system status indicator on the display will stop flashing and will instead be shown in solid red to indicate that the alarm has been acknowledged.

3.4.2 Clearing alarms and hysteresis

To avoid nuisance re-triggering of alarms when a sensor reading is fluctuating around an alarm set-point, each alarm has a hysteresis band applied to it. This hysteresis applies to the clearing of an already triggered alarm. An alarm will always trigger immediately when the sensor reading passes the set-point in the correct direction. However, when the sensor returns in the opposite direction through the same set-point, it must go an amount beyond the set-point before the alarm will clear. This extra amount required to clear an alarm is the alarm's hysteresis. Figure 21 shows an example of a hysteresis band on a high going alarm.

The hysteresis applied to an alarm is adjusted automatically based on the value of the alarm set-point. Hysteresis for each sensor range is defined by a percentage of set-point and a maximum hysteresis value. The hysteresis applied to the alarm is the smaller of the two values for a particular set-point. Table 1 shows the hysteresis applied to each of the current sensor ranges.

Sensor range	Percent of set-point hysteresis	Maximum hysteresis
0-100% oxygen	5	0.5 %
0-3000 mbar oxygen	5	5 mbar
0-5000ppm carbon dioxide	5	100 ppm
0-10000ppm carbon dioxide	5	100 ppm

Table 1 - Scaled hysteresis values

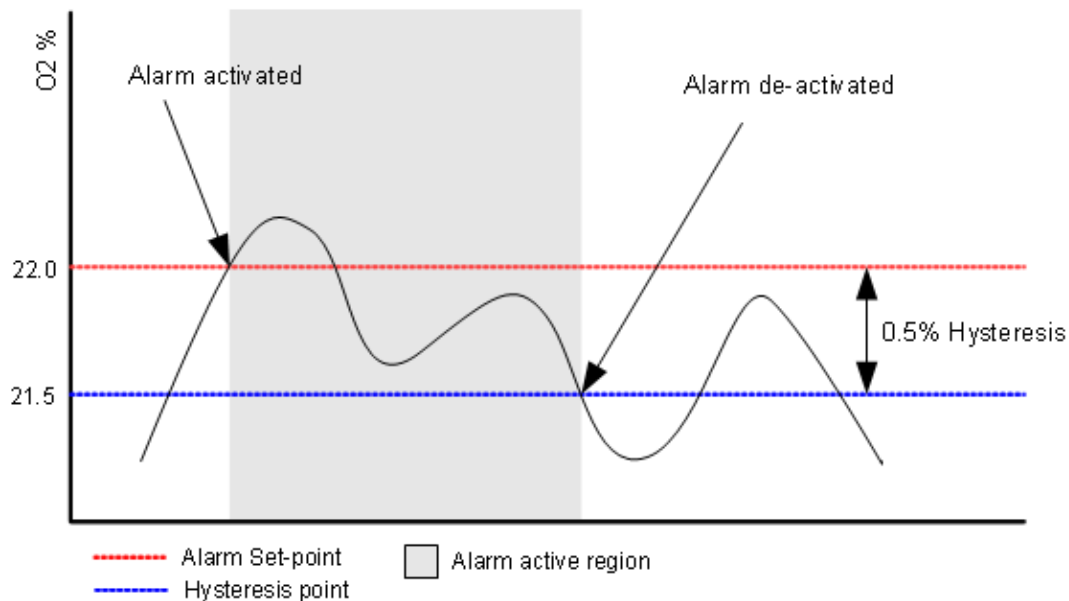

Figure 21 - Hysteresis band on a high going oxygen alarm

3.4.3 Latching alarms

Alarms can operate in either latching or non-latching mode.

With latching alarms **disabled**, if an alarm is triggered and sensor reading subsequently returns to a level that would not trigger the alarm, the visual and audio indicators will be cancelled as soon as the reading passes the hysteresis point (see section 3.4.2).

With latching alarms **enabled**, if an alarm is triggered and the sensor reading subsequently returns to a level that would not trigger the alarm, the visual and audio indicators will continue until the mute button is pressed to acknowledge the alarm. Once acknowledged, the visual and audio indicators will be cancelled. Whilst latching is **enabled**, if an alarm is acknowledged by pressing the mute button prior to the sensor reading passing back through the alarm set-point then the visual and audio indicators will be cancelled as soon as the reading passes the hysteresis point (see section 3.4.2).

For instructions on how to set the latching alarms option see section 4.3.1.

3.4.4 Alarm reminders

In situations where it is important that alarm conditions are not missed, the alarm reminder feature can be enabled. Reminders will re-trigger the horn for an alarm condition if the condition is not cleared after a specified time. The horn will be re-triggered even if it has previously been muted. The horn will not be re-triggered once the sensor reading reaches a level that no longer triggers the alarm.

For instructions on how to set the alarm reminder option and reminder timeout see section 4.3.2.

3.4.5 Adjusting alarm set-points

Each of the SDA's two alarm set-points can be individually adjusted to suit the monitoring application. To adjust a set-point, first select the alarm to adjust by pushing and holding the alarm-adjust toggle switch in the direction of the chosen alarm (up for higher alarm, down for lower alarm - Figure 22).

Note: The alarm-adjust toggle switch must be held in the chosen state until the new set-point is confirmed. Releasing the switch prior to confirmation will return the set-point to its original value.

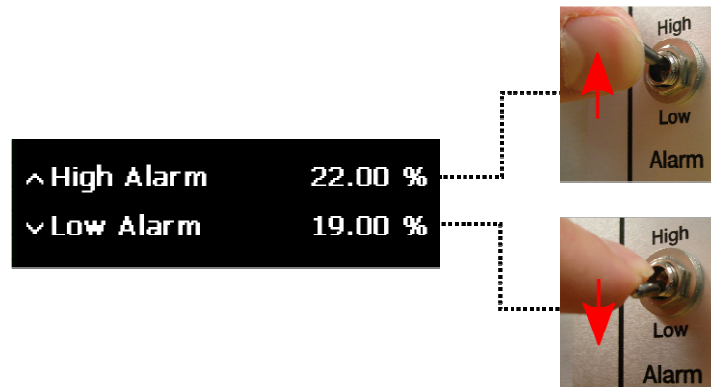

Figure 22 - Selecting an alarm to adjust

When the alarm-adjust toggle switch is held in the adjustment position, the alarm adjustment panel will be shown in place of the alarm set-points panel (Figure 23 - 1) showing the name of the alarm to be adjusted and the current alarm set-point, coloured yellow.

Using the adjustment knob, the set-point can be adjusted by rotating the knob clockwise to increase the set-point and anti-clockwise to decrease the set-point (Figure 23 - 2).

Once the desired new set-point is shown, press the set button to confirm the value. Once confirmed the set-point number displayed will turn green (Figure 23 - 3). Once the new set-point is confirmed, alarm-adjust toggle switch can be released. The alarm set-points panel will return to the screen showing the new value for the alarm set-point which was adjusted.



Figure 23 - Example of alarm set-point adjustment

3.5 Calibration adjustment

Whilst in use, an SDA's sensor should be periodically calibrated at intervals deemed necessary for the monitoring application by exposing the sensor to gas of a known concentration. Calibration adjustments of the sensor's output can be made where necessary as follows.

Each sensor's output is defined by two calibration points, one low and one high. To perform a successful calibration adjustment, both low and high calibration points should be adjusted.

Note: The high and low calibrations performed on a sensor should be selected appropriately. Some sensors (e.g. carbon dioxide) require that the low calibration is a true zero calibration adjustment. For these sensors, a gas with a known zero concentration of the target gas should be used. For other sensors where the low calibration adjustment is not restricted, a high and low calibration adjustment value should be selected. The selected gas concentrations should best reflect the range over which the sensor is intended to be used for greater reading accuracy.

Typically, a % oxygen sensor (MECO2ABB) monitoring a sample line in a saturation diving scenario, at a depth of 200msw, and maintaining an oxygen partial pressure of 400mbar ppO₂, the analyser is expected to read 1.90%. Therefore the high calibration gas in such a case is likely to be chosen between 3 and 5% oxygen in helium, which ensures that the analyser is calibrated close to the point of interest. It is vital that at shallower depths, the analyser is recalibrated, since any errors at this calibration point will be magnified at shallower depths, when the oxygen content is higher. Note that the MEC O₂ % and the SDA CO₂ sensor modules contain an atmospheric pressure sensor which will automatically compensate for pressure effects on the gas during calibration (observe safety warnings on helium ingress, see section 9.3).

To calibrate the partial pressure oxygen sensor (MECO2AABP) the operator must enter the correct partial pressure gas value at the SDA Monitor. If the sensor is in a hyperbaric atmosphere, for example in a Saturation Dive Chamber this value may be derived from other sensors monitoring the chamber. If the sensor is at atmospheric pressure and bottled calibration gas is used then the certified partial pressure value of the calibration gas must be calculated by the operator when the calibration step is performed. Note that the partial pressure MEC O₂ sensor does not include automatic atmospheric pressure compensation.

A gas containing 50% O₂ would be equivalent to 500mbar at the sensor under exactly 1bara atmosphere. The operator must adjust the calibration value according to the current atmospheric pressure, so for this gas if the pressure is 1017mbara, (1.017bara) then multiplying 500mbar by 1.017 will determine that 508.5mbar of O₂ will be present at the sensor. The operator can enter this compensated value during the calibration step, see below.

3.5.1 Performing an adjustment

To perform a calibration adjustment, first expose the sensor to the appropriate calibration gas of known concentration. The sensor should be allowed to settle for a period of time so that the sensor reading can stabilise. This will depend on both the settling time of the sensor and on the length of pipe-work and the flow rate of gas between the gas source and the sensor.

Once the sensor reading has settled for the applied calibration gas, the calibration adjustment can begin by pushing and holding the Calibration toggle switch in the direction of the calibration point to be adjusted (up for high calibration adjustment, down for low calibration adjustment).

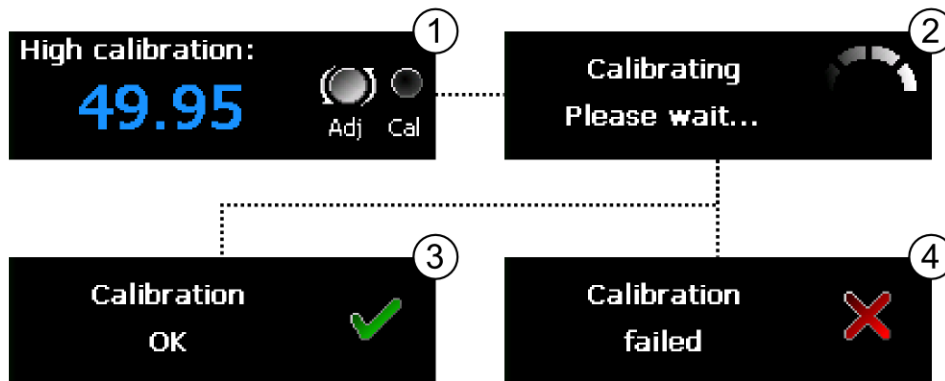

Figure 24 - Calibration adjustment

With the toggle switch held, the calibration value entry panel will be shown (Figure 24-1) with the value coloured blue. Rotating the adjustment knob allows the calibration value to be increased or decreased. The adjustment knob should be rotated until the known concentration of the calibration gas is displayed.

Note: The calibration value that can be entered is limited to zero as a minimum value and the maximum range of the sensor plus 10% for the maximum calibration value. For certain sensors (e.g. carbon dioxide) the low calibration must be performed with zero concentration of the target gas. In these cases the calibration adjustment value cannot be changed by rotating the adjustment knob and the display will show the word 'zero'.

To begin the calibration adjustment process, press the set button. If the calibration toggle switch is released at any time before the set button is pressed then the adjustment will be aborted.

Once an adjustment has begun the sensor will take a moment to process the adjustment request (Figure 24-2) and will decide whether the value supplied is reasonable. See troubleshooting (Section 5) for possible invalid calibration conditions.

If a calibration adjustment is accepted then a 'Calibration OK' message will be shown (Figure 24-3). Should an adjustment request be rejected then a 'Calibration failed' message will be shown instead (Figure 24-4). Both of these messages can be cleared by pressing the mute button.

After any calibration adjustment request is processed, the sensor may enter a warm-up state for a few seconds during which time the sensor reading will not be available.

3.5.2 Calibration adjustment reminders

For situations where regular calibration adjustments are performed, a useful reminder can be enabled using the SDA software. For instructions on how to enable and configure the calibration adjust reminder feature see section 4.3.2.

When enabled, the SDA will show a flashing reminder below the sensor reading when a calibration adjustment is due (Figure 25). The reminder is displayed when the time since the last full high and low calibration adjustment was performed exceeds the reminder period specified when the feature is enabled. If the feature is disabled, no reminder will be displayed.

A calibration adjustment reminder will only be cleared once a both a high and low calibration adjustment have been performed. Both adjustments should be performed with as little time between as possible. If not performed together, the calibration adjustment reminder will be shown based on the time of the earlier of the two adjustments.

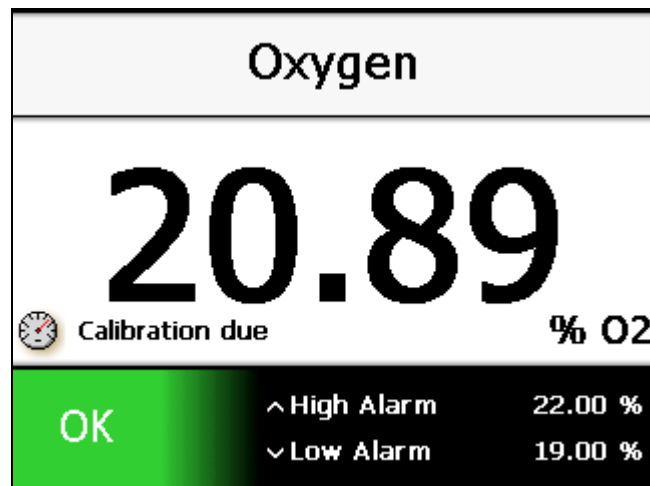

Figure 25 - A calibration adjustment reminder

3.6 Menu

The device main menu can be accessed from the main screen by pressing the set button. The sensor reading shall remain in screen whilst the menu is display as show in Figure 26.

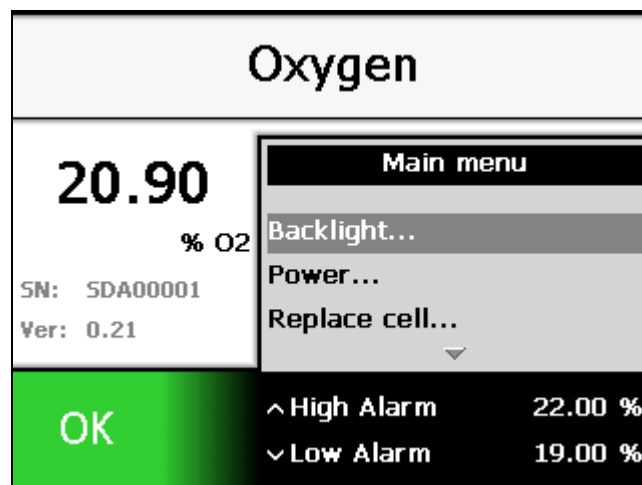

Figure 26 - The main menu

The highlighted menu option can be changed by rotating the adjustment knob. Clockwise moves the cursor downwards and anti-clockwise moves it upwards. An arrow at the top or bottom of a menu indicates that there are more menu options above or below those currently shown.

To select a menu item, highlight it and press the set button. Depending on the menu item selected, the selected action will be performed or a sub-menu will be displayed. Figure 26 shows the main menu with the backlight menu item highlighted. Pressing set displays the backlight sub-menu as shown in Figure 27 which shows that a backlight value of 40% has been selected. Pressing the set button will set the display backlight to 40%. The backlight menu will remain on-screen and can be closed by selecting exit or by pressing the mute button.

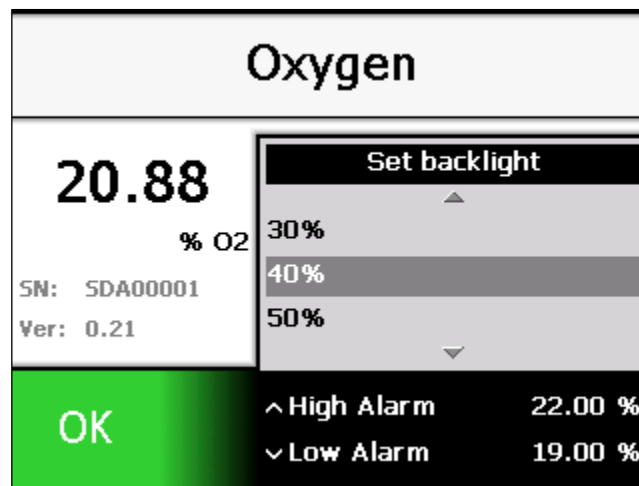

Figure 27 - The backlight sub-menu

Selecting the back option from a sub-menu will return to the previous menu level. The mute button can be pressed at any time whilst using the menu to return to the main screen.

3.7 Adjusting the backlight

The brightness of the SDA display can be changed to suit the lighting conditions of its location by adjusting the backlight intensity. To adjust the backlight level, enter the main menu and select 'Backlight'. Next select the desired backlight intensity level (10-100%) from the menu.

Note: Due to the nature of the display technology, the maximum intensity of the display will slightly degrade over the lifespan of the product. For new systems it is recommended that the backlight is set to an initial intensity level of 60% or less to maximise the lifespan of the display.

3.8 Viewing device information

To view a range of information about an SDA including serial number, enabled options and attached peripherals access the main menu and select the 'Information' option. This will display the device information screen (Figure 28). To close the information screen and return to the main screen, press the mute button.

Information			
Version:	0.21	Data logging:	Yes
Serial no:	SDA00345	Output module:	No
Date:	2011-03-21		
Alarms		Sensor	
Latching:	No	Cal due:	n/a
Repeating:	No	Change due:	Now
OK		^ High Alarm	22.00 %
		v Low Alarm	19.00 %

Figure 28 - The device information screen

3.9 Data-logging

If the data-logging feature is enabled on an SDA then it will maintain a log of system and sensor data whenever the device is powered up. Data is logged every 10 seconds and includes the system status, average, minimum and maximum readings for the 10 second period. An SDA operates a 90 day rolling log. Once 90 days worth of data is collected, the oldest day's data will be deleted so only the most recent 90 days are recorded.

Data can be downloaded into daily log files in .CSV (comma-separated values) format for easy import into popular spreadsheet applications. For instructions on downloading data-log files see section 4.4. An example of a typical data log file is shown below.

Date	Time	Status	Units	CO ₂ Average	CO ₂ Max	CO ₂ Min
28/02/2011	14:34:10	OK	ppm	397	399	395
28/02/2011	14:34:20	OK	ppm	398	400	398
28/02/2011	14:34:30	OK	ppm	401	402	400
28/02/2011	14:34:40	Fault	ppm			

3.10 Serial data output

Under normal operation, without an output module attached to the device (see section 3.11), an SDA will continuously output information about the current system status and sensor reading via the data port. The data is output via an RS485 serial stream in a readable ASCII format. For details of how to make a correct physical connection to the data port in order to collect the output data see section 2.3. The set-up parameters for an external system to correctly receive the output data are as follows.

BAUD rate:	9600
Date bits:	8
Parity:	None
Stop bits:	1
Flow control:	None

The format of the data output stream is a comma-delimited ASCII character string terminated by a carriage return character (0Dh) and a line feed character (0Ah). A terminated character string is output once per second. This stream is designed to be read and displayed by a terminal program, written to a text file for data-logging or captured by a third party software to be interpreted and used in external applications. The comma delimited nature of the string allows it to be easily logged to a .CSV file for simple import into popular spreadsheet applications.

The content of each terminated string consists of the following:

- Date (YYYY-MM-DD)
- Time (HH:MM:SS)
- System status (OK or Fault)
- The units type of the sensor data to follow (% , ppm, etc)
- The average sensor reading
- The minimum sensor reading since the last data string
- The maximum sensor reading since the last data string

The following shows two examples of typical data strings. The second shows a fault condition in which case the sensor readings are not shown.

```
2011-03-23,09:49:31,OK,ppm,625,625,625↵
2011-03-24,10:36:12,Fault,%, , , ↵
```

3.11 Output module

To expand an SDA to provide relays and an analogue output an optional Analox output module can be connected to the system.

3.11.1 Connecting an output module

To connect an output module, the SDA should first be disconnected from the DC power supply. The output module communication cable should be connected to the Data port on the rear of the SDA (see section 2.2.4 for instructions on connecting to the Data port).

When power is applied to an SDA with an output module is connected it will automatically recognise that the module is connected. A few seconds after the main screen is shown on start-up, the output module will begin to reflect the sensor reading and alarm status. The

connection status of an output module can be viewed on the information screen (see section 3.8).

3.11.2 Relays

An output module provides two relays. Each relay is mapped to one of the SDA alarms. Relay 1 is mapped to the lower alarm and Relay 2 is mapped to the higher alarm (Figure 29). If an alarm is not active then its corresponding relay will be in the energised state (connection between Com and NO is made). If an alarm is triggered then the corresponding relay will switch to the de-energised state (connection between Com and NC is made).

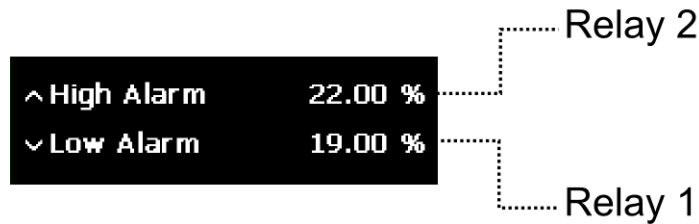

Figure 29 - Alarm relay mapping

If any system fault is detected then both relays will switch to their de-energised alarm states to correspond with the fault alarm that is raised for a system fault.

3.11.3 Analogue output

The output module's analogue output is used to reflect the SDA's sensor reading. The nominal range of the output current is 4-20mA (see section 2.3 for connection details). This range corresponds to the range of the sensor attached. For example, for a 5000ppm ranged carbon dioxide sensor, 0ppm carbon dioxide measured will correspond to an output of 4mA and 5000ppm carbon dioxide measured will correspond to an output of 20mA.

If any system fault is detected then the analogue output will output a current beyond the 20mA upper range of the sensor range (approx. 22mA) to correspond with the fault alarm that is raised for a system fault.

3.11.4 Communication & power faults

If a faulty or intermittent connection exists between an SDA and an output module whilst the output module remains powered then the output module will assume a fault and set its relay and analogue output to their fault states as described above.

If power to an output module is lost, the relays will return to a de-energised alarm state and the analogue output will output 0mA.

3.12 Power modes

When connected to a DC power supply, and SDA device will start up automatically and remain powered whilst connected.

3.12.1 Sleep mode

An SDA can be switched into a sleep mode which will allow the device to remain powered but silent. No alarms will be raised whilst in sleep mode. Also in sleep mode, the display will be powered down and any data-logging enabled will be paused. The unit and sensors will remain

powered to allow for a quick wake-up from sleep mode. All buttons except for the set button will be disabled whilst in sleep mode.

To switch the device into sleep mode, access the main menu (see 3.6) and select “Power...” followed by “Sleep”.

To wake the device from sleep mode, press the set button. The display will be switched on, monitoring for alarms will begin again and data-logging will re-commence.

3.12.2 Restarting

To prompt a full reboot of an SDA device, access the main menu (see 3.6) and select “Power...” followed by the “Restart...” option. This option will ask for confirmation. Selecting yes will force the system to restart.

3.13 Cell replacement reminder

For SDA sensors which use electrochemical technology, such as the MEC O₂ sensor, the electrochemical cell part of the sensor needs to be periodically replaced as the cell depletes. To aid with the timely replacement of cells the SDA provides a cell replacement reminder feature. This feature is only available for sensors which require cell replacement (e.g. oxygen). Sensors which do not use electrochemical technology (e.g. carbon dioxide) do not use this feature.

The cell replacement reminder feature can be enabled or disabled using the SDA software as described in section 4.3.2.

If the cell replacement feature is enabled and the sensor is an electrochemical type, the SDA will show an onscreen warning when the cell is due to be replaced as shown in Figure 30. The cell replacement reminder is shown once the number of days that have elapsed since the cell was last replaced exceeds the cell replacement reminder period defined using the SDA software.

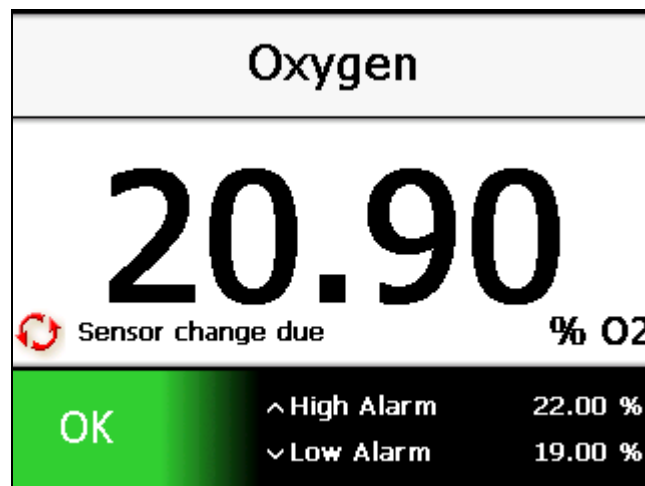

Figure 30 - Sensor change reminder

The cell reminder period can be adjusted using the SDA software to suit expected sensor usage. For example, some oxygen cells are expected to last for 2 years in atmospheric levels of oxygen. However, oxygen cells will deplete faster if they are exposed to higher levels of oxygen, so if the sensor is expected to be exposed to higher levels of oxygen over its service then the reminder period can be shortened in order to serve as a reminder that the cell is expected to age more quickly.

Note: The cell replacement feature is intended to be used only as a guide and cannot accurately determine the lifespan of a cell. If a sensor becomes difficult to calibrate after a period of time in service then it should be replaced regardless of the reminder status.

3.13.1 Replacing a cell and resetting the reminder

Once an electrochemical cell has been replaced (see section 6.1), the cell replacement reminder will continue to be shown and needs to be manually reset. For SDAs which use electrochemical sensors, this warning can be reset from the SDA menu. To do this open the main menu and select 'Replace cell...'. Upon confirmation, this will store the current date as the date on which the cell was last replaced.

4 Configuration

In order to set options on an SDA, the SDA software is provided to allow a device to be configured using a USB connection. The SDA software is designed to run on Microsoft Windows®.

4.1 Software installation

Note: Before connecting an SDA to a computer, the appropriate software should be installed.

4.1.1 Software requirements

The SDA software is designed to run on Microsoft Windows® and has the following prerequisites:

- Microsoft Windows XP®, Windows Vista® or Windows 7®
- Microsoft .NET Framework 3.5 SP1 or later
- Microsoft ActiveSync® 4.5 or later (Windows XP® only)
- Microsoft Windows Mobile Device Center 6.1 or later (Windows Vista® & Windows 7® only)

4.1.2 Windows® XP Installation

To install the SDA software on Windows XP® perform the following steps.

- 1) If not already installed, install Microsoft ActiveSync® 4.5 or later. This software is available as a free download from the [Microsoft Download Center](#)
- 2) From the SDA software disk, run the installer file called 'Setup'.
- 3) The installer will check that the .NET Framework 3.5 SP 1 is installed. If not you will be prompted to allow the framework to be installed. Alternatively the .NET Framework is available as a free download from the [Microsoft Download Center](#)
- 4) Once the installer is satisfied that the .NET Framework is installed, the SDA installer wizard will be displayed. Follow the on-screen instructions to install the SDA software.

4.1.3 Windows® Vista & Microsoft Windows® 7 Installation

To install the SDA software on Windows® Vista or Windows7® perform the following steps.

- 1) If not already installed, install Microsoft Windows Mobile Device Center 6.1 or later for the appropriate version of Windows. This software is available as a free download from the [Microsoft Download Center](#) ensuring that the appropriate download is selected for the version of Windows®.
- 2) From the SDA software disk, run the installer file called 'Setup'.
- 3) The SDA installer wizard will be displayed. Follow the on-screen instructions to install the SDA software.

4.1.4 Running the software

To run the SDA software, select the program from the Windows® start menu, Analox folder. When the software runs without a device connected, the window shown in Figure 31 will be displayed.

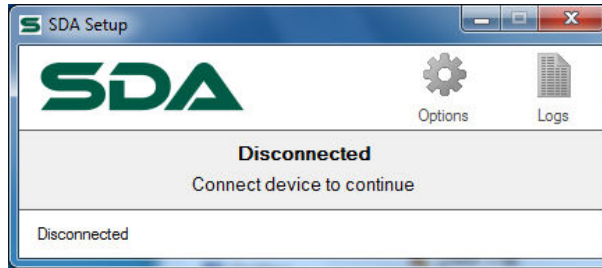

Figure 31 - SDA software without device connected

4.2 Making a connection

Note: The SDA software uses Microsoft ActiveSync® to communicate with an SDA. Before connecting to an SDA, ensure that any other windows mobile devices or devices which make use of ActiveSync® are disconnected from the computer.

Always connect only one SDA to the computer at a time. To connect an SDA to the computer, connect one end of the USB cable provided to the SDA PC port on the rear panel and connect the other end of the cable to a free USB port on the computer. Power the SDA device and allow it to start up.

Once connected and powered, Windows® should detect the device and display an information bubble confirming the connection. On the first time connecting an SDA to the computer, message bubbles may be shown explaining that device drivers are being installed. This should take a few moments.

When the device connects, on Window XP® systems, the ActiveSync window will pop up. This window should be closed. On Window 7® systems, the Windows Mobile Device Center window will be shown. This window should be closed.

If not already open, run the SDA software. The SDA software will recognise the device and read the current settings form the device. Once fully connected the window shown in Figure 32 will be displayed.

4.2.1 Disconnecting

To disconnect an SDA from the computer, first wait until all settings have been saved correctly and that any file downloads have completed then remove the USB cable from the computer.

4.3 Changing options

On connection to an SDA, a copy of all of the device's options is created in the SDA software. The options are presented over a set of tabs. To view the options tabs, click the 'Options' button. Using these tabs the options can be viewed and modified as required. No changes are made to the device's options until the changes are applied to the device. To apply any changes made click the 'Apply Changes' button (shown in Figure 32). This will upload the new options to the device. The SDA will confirm that the options have been saved by playing a confirmation sound.

Any changes made to options can be discarded as long as they have not yet been applied to the device. To re-download the current device settings form an SDA, click the 'Read Options' button (shown in Figure 32).

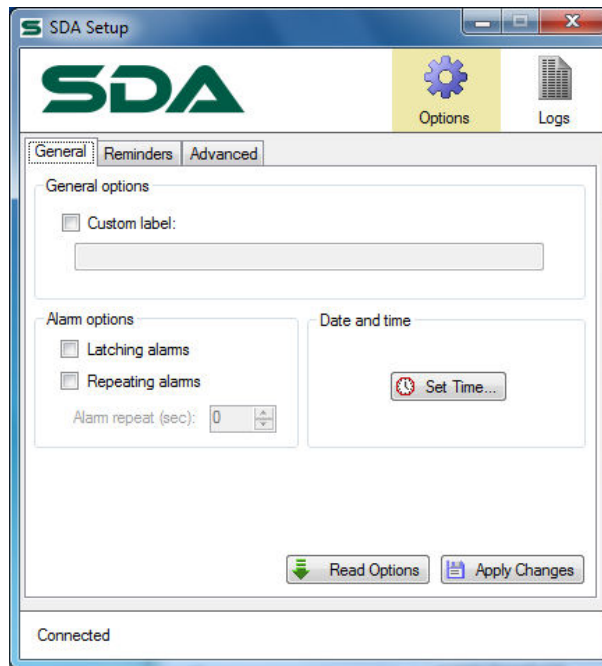

Figure 32 - SDA software with device connected showing general options

4.3.1 General options

The general device options are displayed by clicking on the 'General' tab. Figure 32 shows the general options.

Custom label

A custom label can be enabled by checking the 'Custom label' checkbox. If enabled, a custom text label can be added to the text box. This will instruct the SDA to display a custom text label on its main screen as described in section 3.2.3.

If the custom label checkbox is unchecked then the device will show a default label which will be the configuration type (e.g. 'Oxygen').

Latching alarms

The latching alarms checkbox enables or disables latching alarms as described in section 3.4.3.

Repeating alarms

The repeating alarms checkbox enables or disables the alarm reminder feature as described in section 3.4.4. If the repeating alarms feature is enabled, an alarm repeat interval should be set. This defines the time in seconds before a muted alarm will be re-triggered. Setting this value to zero will automatically disable the feature.

Date and time

The 'Set Time...' button can be used to set the date and time on the device as described in section 4.5.

Note: Any changes made to the general options will not come into effect on an SDA device until the 'Apply Changes' button has been clicked with the exception of setting the date and time (see section 4.5).

4.3.2 Reminder options

The reminders options are displayed by clicking on the 'Reminders' tab. Figure 33 shows the reminders options.

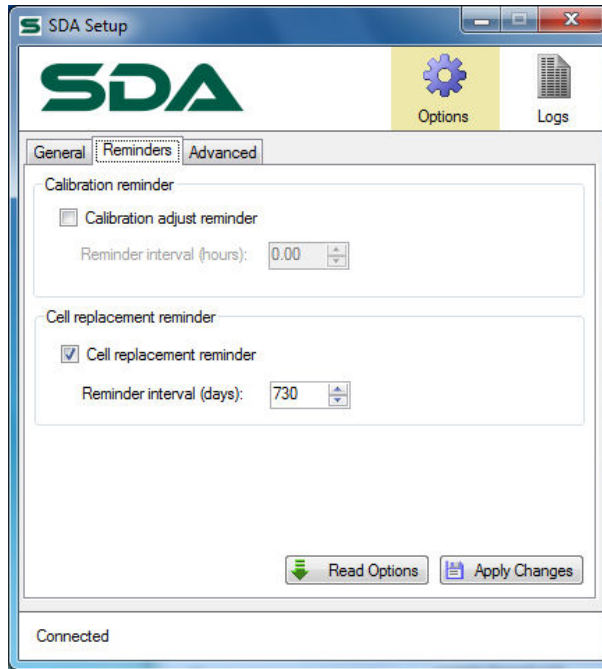

Figure 33 - Reminder options

Calibration adjust reminder

The 'Calibration adjust reminder' checkbox enables or disables the calibration adjust reminder as described in section 3.5.2. If the calibration adjust reminder feature is enabled, a reminder interval should be set. This defines the time in hours since the last full calibration adjust before a calibration adjust reminder will be displayed on the SDA. Setting this value to zero will automatically disable the feature.

Cell replacement reminder

The 'Cell replacement reminder' checkbox enables or disables the cell replacement reminder as described in section 3.13. If the cell replacement reminder feature is enabled, a reminder interval should be set. This defines the time in days since the cell was last replaced before a cell replacement reminder will be displayed on the SDA. Setting this value to zero will automatically disable the feature.

Note: For sensors where there is no cell to replace such as carbon dioxide, this feature will have no effect and cell replacement reminders will not be shown on the SDA. This feature applies only to sensors with electrochemical cells which deplete over time.

4.4 Downloading data logs

If an SDA is enabled with internal data-logging then the data stored on the device can be downloaded using the SDA software. To view the data-log management controls, click the 'Logs' button (Figure 34). If data-logging is enabled on the device, a list of the data-log files available on the device will be shown. This list will be empty if data-logging is not enabled.

The data-log files are stored by date. Each date's file contains all of the data logged whilst the device was running during a particular day. This list can be refreshed by pressing the 'Refresh' button.

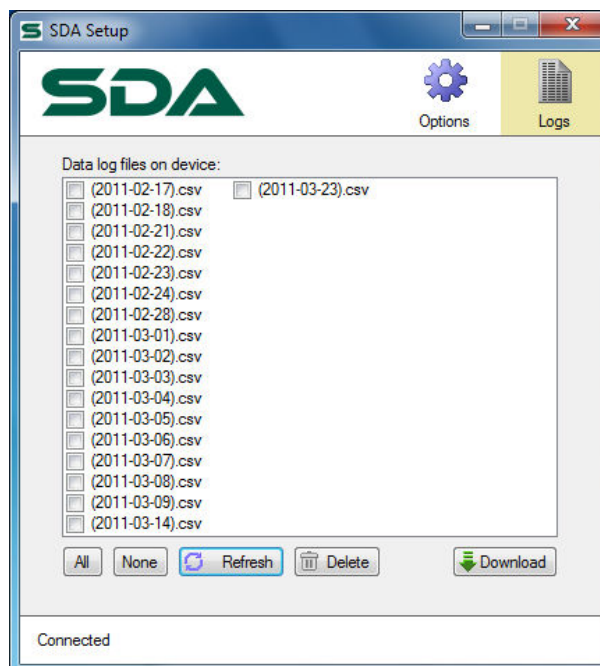

Figure 34 -The data logs available on a connected SDA

Data-log files can be downloaded individually or in batches. To select the files that are to be downloaded, click on the checkbox next to each of the files of interest. The 'All' and 'None' buttons can be used to select or deselect all of the files respectively. Once a selection has been made, the log file download can be started by clicking the 'Download' button. Figure 35 shows a selection of files being downloaded.

Note: The time taken to download data logs will vary depending on the number of log files selected and the amount of log data inside each file. This process may take several minutes. It's should also be noted that downloading a full data log may download up to 50MB of log data. Please ensure that there is enough storage space on the target disk before beginning a download.

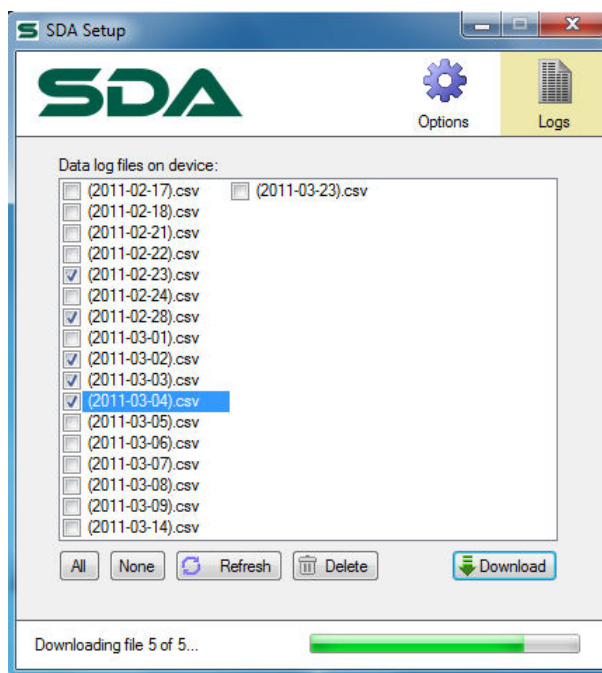

Figure 35 - Downloading data logs from an SDA

Although the internal data-logging operates a rolling log with automatic cleanup of older data, the data-logs on the device can be managed manually using the SDA software. To delete unwanted files from a device, select the files for deletion and click the 'Delete' button.

4.5 Setting the time

The SDA's internal date and time is used for data-logging and for issuing various reminders. The internal clock can be set to the appropriate date and time using the SDA software. With an SDA connected to the SDA software, select the 'General' tab. Click the 'Set Time...' button. This will display the window shown in Figure 36. The default time shown will be the system date and time of the computer running the software. This date and time can be changed if required. To set the date & time on the device click OK. The SDA will play a sound to acknowledge that the date and time have been set successfully.

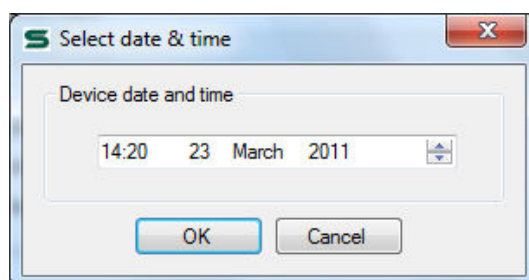

Figure 36 - Setting the date and time on an SDA

5 Troubleshooting

5.1 Fault conditions

An instrument constantly monitors itself for fault conditions. Any fault conditions that are identified will trigger a fault alarm. When a fault alarm is raised, the horn will sound immediately. Faults will be indicated on the display by flashing the system status indicator in yellow as shown in Figure 37. Fault alarms can be muted in the same way as standard alarms by pressing the mute button. When pressed, the horn will deactivate and the system status indicator will be shown as solid yellow to indicate that the fault has been acknowledged.

All fault alarms are latching so if an intermittent fault is identified and subsequently cleared, the alarm will continue to be displayed and sounded until the mute button is pressed to acknowledge the fault.

Information about the fault condition identified is displayed below the sensor reading as shown in Figure 37 in which a sensor communication fault is shown. In cases where a fault prevents a valid reading from being obtained from a sensor then the reading will not be shown on the display and will instead be replaced by '---'.

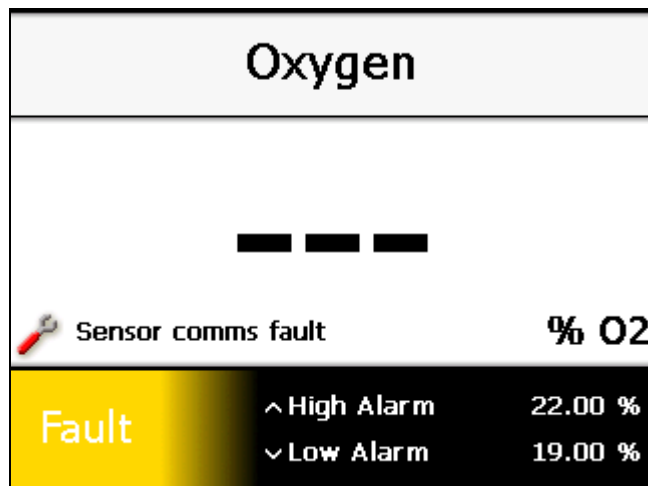

Figure 37 - A system showing a fault condition

5.2 Fault logging

All instances of fault conditions that are identified will be logged to the instrument's diagnostics log. Both the point at which the fault is identified and the point at which the fault is cleared will be logged. The diagnostics log can be downloaded using the SDA software. To download the log, connect to the device as described in section 4. Access the 'Advanced' tab and click 'Download diagnostics log...'. This will give the option to specify a save location for the log file.

5.3 Problems and actions

Problem	Action
'Sensor comms fault' shown on the display.	<ul style="list-style-type: none">• A serial communication link has been lost with the sensor.• Check that the sensor connector is firmly connected to the sensor port at the rear of the unit.• Check that all screw terminal connections and cable crimps are securely fitted to the sensor connector and that the wires are connected to the correct terminals.• Check that the cable that connects to the sensor is not damaged.
'Sensor range fault' shown on the display	<ul style="list-style-type: none">• The sensor is detecting a condition outside of its effective range.• Check that the sensor is not being exposed to conditions outside of its effective range.• Re-calibrate the unit.• Restart the SDA device.• If the problem persists, please contact your supplier.
'Sensor fault' shown on the display	<ul style="list-style-type: none">• The sensor has detected a fault in its operation.• Restart the SDA unit.• If the problem persists, please contact your supplier.
'Sensor fatal error' shown on the display	<ul style="list-style-type: none">• The sensor has detected a fault in its operation.• Restart the SDA unit.• If the problem persists, please contact your supplier.

6 Maintenance

6.1 Oxygen cell replacement

Replacement part number for your cell is: 9100-9212-9HM

When a replacement cell is received check that the sensor has not leaked. The sensors are themselves sealed and do not under normal circumstances present a health hazard however if leakage of the electrolyte has occurred use rubber gloves and wear chemical splash goggles to handle and clean up. Rinse contaminated surfaces with water. If anybody comes into contact with the electrolyte, please refer to section 9.1 for safety and handling guidelines.

- 1) Ensure all electrical connections between the MEC and monitor equipment are disconnected.
- 2) Loosen the corner screws of the enclosure and remove the lid.

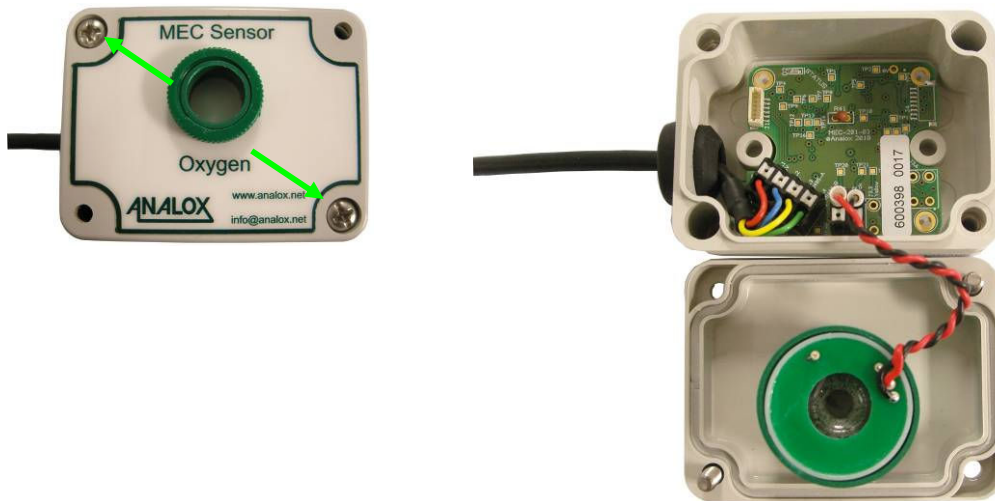

Figure 38 - Removing the MEC lid

- 3) Using a terminal screwdriver push down the clamp release button to release the clamp and gently pull the cell wire from the clamp. Repeat this for both the red and black wires.

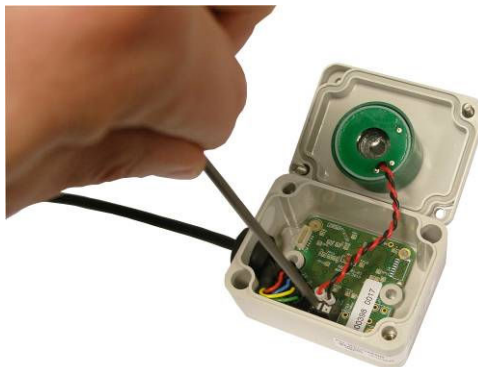

Figure 39 - Disconnecting the cell

- 4) Unscrew the green lock ring from the chimney of the cell housing and remove from the enclosure lid.



Figure 40 - Removing the cell from the lid

- 5) Fit the new cell in to the enclosure lid and secure in place using the lock ring.
- 6) Using a terminal screwdriver push down the clamp release button to release the clamp. Push the ferrule of the cell wire in to the clamp and remove the screwdriver from the clamp release button. Gently pull on the wire to ensure that the wire is held by the clamp. Repeat this for both the red and black wires, taking note of the correct polarity as shown below.

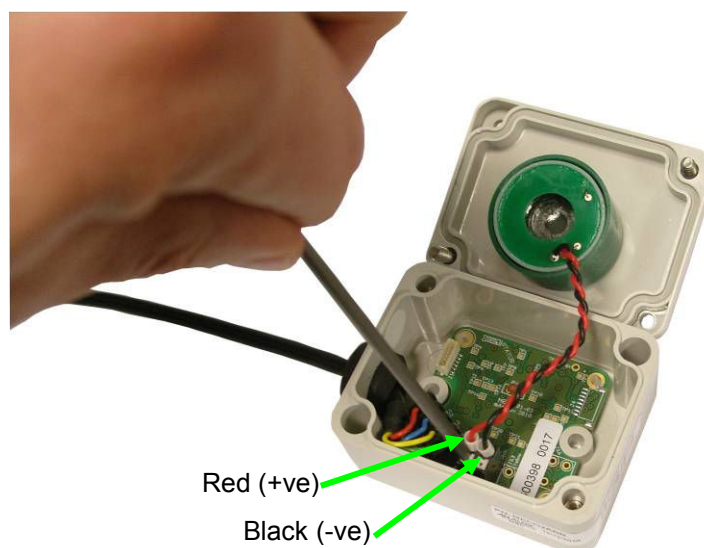

Figure 41 - Connecting a new cell

- 7) Fit the enclosure lid and secure in place using the corner screws.
- 8) Following an oxygen cell replacement a full calibration MUST be performed, as described in section 3.5.
- 9) If the cell replacement reminder option is in use then the reminder must be manually reset after replacing the cell, as described in section 3.13.1.

6.2 Reconfiguring a unit

Warning: The procedure for reconfiguring a unit should be performed under the understanding that it will remove all current settings from a unit and write default settings for a new configuration to the device. Only perform this procedure if you are certain you wish to re-configure a device.

It may occasionally be necessary to change the configuration of a unit to operate with a different sensor or range, for example, when configuring a spare SDA to be swapped out for another unit.

Re-configuration of a unit is performed by using XML configuration files. You may need to contact your supplier to be provided with a set of configuration files. Re-configuration is performed using the SDA software. In order for the configuration files to be available to the SDA software they should be placed in a folder named 'config' within the folder from which the SDA software runs. This will usually be at the location 'C:\Program Files\Analog\SDA Setup\config' but may vary depending on the location chosen on installation of the software. The SDA software should be closed and re-opened once the configuration files are correctly located.

Once the configuration files are available to the software, connect a device and access the 'Advanced' tab (Figure 42). From the drop down menu under 'Device configuration' select the appropriate configuration file and click 'Configure...'. A warning will be shown explaining the implications of re-configuring a device. Click OK to start the re-configuration.

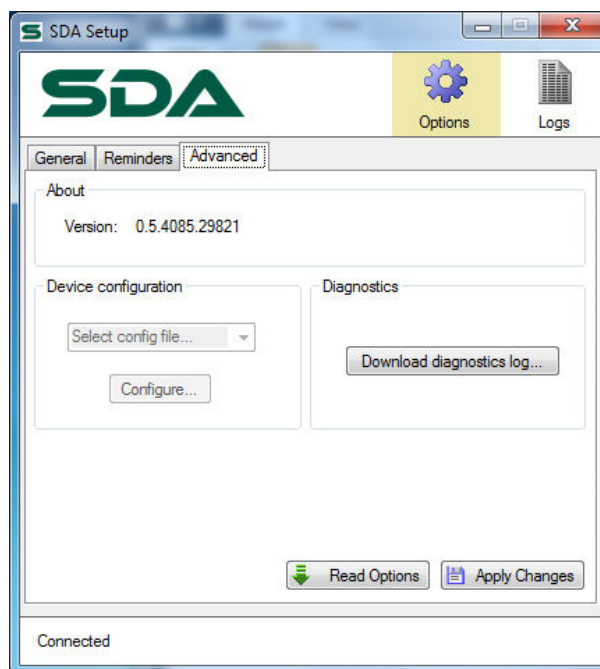

Figure 42 - Advanced options

The new configuration shall be uploaded to the device and a sound will be played by the SDA when the upload is complete.

Note: Following a re-configuration, the device should be powered down and re-powered before use.

7 Spares and Accessories

Spares

Description	Part Number	Service / Replacement Intervals
9212-9HM for MEC O ₂ Sensor Assembly	9100-9212-9HM	2 years
O ₂ MEC sensor module, 0-100% O ₂ **	MECO2ABB	2 years (cell only)
O ₂ MEC sensor module, 0-3000mbar ppO ₂ **	MECO2ABAP	2 years (cell only)
Flow Meter for CO ₂ Module/Flow Meter Panel	5981-0502	As required
O ₂ Monitor, Rack (%O ₂)*	SDARAAXA	As required
O ₂ Monitor, Panel (%O ₂)*	SDAPAAXA	As required
O ₂ Monitor, Rack (ppO ₂)*	SDARAEXA	As required
O ₂ Monitor, Panel (ppO ₂)*	SDAPAEXA	As required
CO ₂ Monitor, Rack (5000ppm CO ₂)*	SDARBBXA	As required
CO ₂ Monitor, Rack (10000ppm CO ₂)*	SDARBCXA	As required
CO ₂ Monitor, Panel (5000ppm CO ₂)*	SDAPBBXA	As required
CO ₂ Monitor, Panel (10000ppm CO ₂)*	SDAPBCXA	As required
CO ₂ Module, Rack, - 0-5000ppm in N ₂	SDARCO2ASN	5 years
CO ₂ Module, Rack, - 0-5000ppm in He	SDARCO2ASH	5 years
CO ₂ Module, Rack, - 0-10000ppm in N ₂	SDARCO2ALN	5 years
CO ₂ Module, Rack, - 0-10000ppm in He	SDARCO2ALH	5 years
CO ₂ Module, Panel, - 0-5000ppm in N ₂	SDAPCO2ASN	5 years
CO ₂ Module, Panel, - 0-5000ppm in He	SDAPCO2ASH	5 years
CO ₂ Module, Panel, - 0-10000ppm in N ₂	SDAPCO2ALN	5 years
CO ₂ Module, Panel, - 0-10000ppm in He	SDAPCO2ALH	5 years

* Data logging option is available with all monitors, please enquire.

** Only the 9212-9HM electrochemical cell replaced, sensor electronics and case are reused.

Accessories

Description	Part Number
O ₂ & PSU Bracket Kit	XK0-472K
O ₂ Only Bracket Kit	XK0-473K
Monitor Power Supply	XK0-662
Output Module - Current	SDAOMCURRENT
Flow Meter Panel - Panel Mount	SDAFMPANEL
Flow Meter Panel - Rack Mount	SDAFMRACK

8 Specifications

8.1 SDA Monitor

Power Source	External stabilised 12-32V DC supply, (regulation < $\pm 300\text{mV}$). External 110-230V AC supply (option only).
Operating Current	SDA Monitor: Maximum 640mA at 24V DC supply SDA O ₂ System: Average 200mA at 24V DC supply SDA CO ₂ System: Average 300mA at 24V DC supply
Fuses	Monitor: Internal 2A slow blow micro fuse on in monitor PCB. Sensor and data ports: 400mA shutdown protection on +5V DC supply.
Display Panel	320 x 240 TFT colour graphic display with 10 brightness levels. Displays current values of measured parameters using 14mm high large characters.
Alarm Indicators	Onscreen visual indication of faults and 2 fully adjustable alarm levels. (optional volt free contacts for individual alarms with SDA Output Module)
Operator Controls	2 x momentary action toggle switches for alarm and calibration functions 2 x momentary action push buttons for mute and function selection 1 x rotary encoder for value adjustment and menu navigation
Environmental Conditions	Rating: IP22 Operating temperature: -5 to +55°C Storage temperature: -10 to +70°C Operating pressure: 700 to 1300 mbar absolute Humidity: 0 to 95% RH at +55°C non-condensing
Dimensions	Rack: 106 x 129 x 31mm Panel: 120 x 133 x 31mm
Weights	Rack: 595g Panel: 665g
Audio	Speaker: 1W, used for user interface navigation. Buzzer: 88dB at 10cm, frequency 2400 \pm 400Hz, alarm and fault indication.

8.2 MEC Oxygen Sensor

Power Source	+5V DC $\pm 500\text{mV}$
Operating Current	Maximum 20mA at +5V DC supply
Detection Mode	Electrochemical
Range and Accuracies	100% O₂ : $\pm 0.035\%$ O ₂ , $\pm 1\%$ of reading, $\pm 0.15\%$ of reading / °C 3000mbar ppO₂ : $\pm 0.35\text{mbar}$ ppO ₂ , $\pm 1\%$ of reading, $\pm 0.15\%$ of reading / °C
Communication Link	RS485 serial data, 9600bps, no parity, 1 stop bit. Distance up to 500m
Environmental Conditions	Rating: IP65 Operating temperature: -5 to +55°C Storage temperature: -10 to +70°C Operating pressure: 700 to 1300 mbar absolute Humidity: 0 to 99% RH at +55°C non-condensing
Dimensions	65 x 50 x 35 mm
Weights	99g
Sensor Life	2 years for the electrochemical cell in atmospheric air
Remote sensor gas flow rate	0.2 to 1.0 litres/minute

8.3 Carbon Dioxide Sensor Module

Power Source	+5V DC \pm 500mV
Operating Current	CO ₂ Sensor: Maximum 390mA at +5V DC supply
Detection Mode	Infra-red
Range and Accuracies	5000ppm CO₂ : \pm 25ppm CO ₂ , \pm 1% of reading, \pm 2.5ppm CO ₂ / °C 10000ppm (1%) CO₂ : \pm 50ppm CO ₂ , \pm 1% of reading, \pm 5ppm CO ₂ / °C
Response Time	T90 in <30seconds
Warm Up Time	40 seconds
Communication Link	RS485 serial data, 9600bps, no parity, 1 stop bit. Distance up to 500m
Environmental Conditions	Rating: IP22 Operating temperature: -5 to +55°C Storage temperature: -10 to +70°C Operating pressure: 700 to 1300 mbar absolute Humidity: 0 to 95% RH at +55°C non-condensing
Dimensions	Rack: 106 x 129 x 194mm Panel: 120 x 133 x 194mm
Weights	Rack: 1393g Panel: 2081g
Sensor Life	5 years in operation
Remote sensor gas flow rate	0.2 to 1.0 litres/minute Maximum sample input pressure 6bara

8.4 SDA Output Module

Power Source	+5V DC \pm 500mV
Operating Current	Maximum 300mA at +5V DC supply
Range and resolution	0 to 23mA FS, 0.023mA
Communication Link	RS485 serial data, 9600bps, no parity, 1 stop bit. Distance up to 500m
Outputs	2 x relays (1 per alarm), volts free, changeover contacts - maximum ratings: 125 VAC, 60 VDC, 1 A, 62.5 VA, 30 W 1 x 4 to 20mA Isolated output (short circuit protected) - maximum load resistance 500Ω standard, 1k Ω high compliance. 1 x status LED
Environmental Conditions	Rating: IP22 Operating temperature: -5 to +55°C Storage temperature: -10 to +70°C Operating pressure: 700 to 1300 mbar absolute Humidity: 0 to 95% RH at +55°C non-condensing
Dimensions	98 x 64 x 38 mm
Weights	118g without cables

9 Safety warnings

9.1 Oxygen Sensor – Caustic Electrolyte

The oxygen sensor is an electrochemical device and contains a caustic electrolyte. Always check to make sure that it is not leaking and do not allow it onto any part of your body or clothing.

When the life of the sensor has expired or it is leaking or otherwise damaged it must be disposed of safely in accordance with local regulations.

The sensor contains Potassium Hydroxide solution (KOH) which is hazardous.

In the event of an accident, use the following first aid procedures:

Body Part	Effect	First Aid Procedures
Skin	Contact could result in a chemical burn. Persons with pre-existing skin disorders may be more susceptible to the effects of the substance.	Immediately flush the skin thoroughly with water for at least 15 minutes. Remove contaminated clothing and wash before re-use. Obtain medical advice if continued irritation.
Ingestion	Corrosive. May cause sore throat, abdominal pain, nausea, and severe burns of the mouth, throat, and stomach, and may be fatal.	If swallowed DO NOT INDUCE VOMITING. Wash out mouth thoroughly with water and give plenty of water to drink. Obtain medical advice immediately
Eye	Persons with pre-existing eye problems may be more susceptible to the effects of the substance. Corrosive. May cause redness, pain, blurred vision, and eye burns. Contact can result in the permanent loss of sight.	Irrigate thoroughly with water for at least 15 minutes. Obtain medical advice immediately.
Inhalation	Persons with pre-existing impaired respiratory function may be more susceptible to the effects of the substance. Inhalation is not an expected hazard unless heated to high temperatures. Mist or vapour inhalation can cause irritation to the nose, throat, and upper respiratory tract.	Remove to fresh air. Rest and keep warm. Obtain medical advice if applicable.

9.2 Pressurised gas

- 1) Do not exceed the specified maximum pressures. Failure to do so may result in damage to the equipment and to personnel.
- 2) Users of this equipment **MUST** be familiar with the handling of pressurised gas.
- 3) Take particular care when handling toxic or flammable gases. In such cases ensure that all exhaust is vented into well ventilated areas.
- 4) For systems with exhaust outlets, do not block the exhaust outlet.

9.3 Helium Ingress

Care must be taken when choosing the location for the SDA sensor modules that include atmospheric pressure compensation. These include the MEC O₂ % (MECO2ABB) and SDA CO₂ modules. Helium can diffuse into the pressure sensing components in the sensor housing and affect the overall sensor accuracy.

To avoid helium ingress issue with the sensor modules, they should be fitted into well ventilated panels or racks where the content in the atmosphere is ideally less than 1% helium. Levels exceeding this will degrade sensor performance and levels greater than 5% will reduce sensor life expectancy. Note that this does not effect the MEC O₂ partial pressure sensor (MECO2AABP) as this does not include automatic pressure compensation.

9.4 ESD and Electric Shock

To prevent damage to the SDA units they must not be operated with any casework removed to prevent the likelihood of damage to the electronic components and accidental electric shock. The rear USB and Ethernet connectors are shielded to an internal electronic ground and should not be connected to protective earth. The stud on the rear of the case provides the main connection to protective earth which must be connected to maintain EMC performance.

9.5 Servicing

Only the electrolytic cell of the MEC oxygen sensor is designed to be user replaceable. Please consult Analox if any other parts from a SDA module require replacement.

9.6 IP Rating and General Care

The SDA Monitor is designed to provide an IP22 rating for the front panel of the SDA Monitor. The Monitor should be fitted into a suitable rack or panel to cover the rear of the unit to provide protection over the rear connectors to at least IP22.

Although designed to be water resistant the MEC oxygen sensors should not be intentionally immersed in liquid or left outside unprotected.

To clean any of the SDA equipment, use a damp soft cloth.

9.7 Disposal



According to WEEE regulation this electronic product can not be placed in household waste bins. Please check local regulations for information on the disposal of electronic products in your area.

10 Warranty Information

We provide the following Warranties for the SDA O₂, SDA CO₂ and associated accessories

- A 1 year electronics warranty.
- A 2 year graded sensor warranty.

In both cases the warranty period runs from the date of our invoice.

We warrant that the equipment will be free from defects in workmanship and materials.

The warranty does not extend to and we will not be liable for defects caused by the effects of normal wear and tear, erosion, corrosion, fire, explosion, misuse, use in any context or application for which the equipment is not designed or recommended, or unauthorised modification.

Following a valid warranty claim in accordance with the above, the equipment, upon return to us, would be repaired or replaced without cost or charge but in our discretion we may elect instead to provide to you which ever is the lesser of the cost of replacement or a refund of net purchase price paid as per our Invoice on initial purchase from us. We shall have no liability for losses, damages, costs or delays whatsoever. We shall have no liability for any incidental or consequential losses or damages. All express or implied warranties as to satisfactory or merchantable quality, fitness for a particular or general purpose or otherwise are excluded and no such Warranties are made or provided, save as set out in this clause.

In order to effectively notify a warranty claim, the claim with all relevant information and documentation should be sent in writing to:

Analox Ltd
15 Ellerbeck Court
Stokesley Business Park
Stokesley
North Yorkshire
TS9 5PT

Or by e-mail to : info@analox.net
Or by Fax to : +44 1642 713900

We reserve the right to require from you proof of dispatch to us of the notification of warranty claim by any of the above alternative means.

The equipment should not be sent to us without our prior written authority. All shipping and Insurance costs of returned equipment are to be born by you and at your risk. All returned items must be properly and sufficiently packed.

Fault Reporting To Analox

Date	
------	--

Customer Details

Customer Contact	
Address	
Country	
Telephone	
Fax	
Email	

Equipment Details (where applicable)

Monitor Serial No	
Sensor Serial No	
Output Module Serial No	
Others	

System Operating Voltage	
--------------------------	--

Customer's Description of Fault	

To be completed by Analox

Date Manufactured	
Monitor SW Version	
Monitor BSP Version	
Design Change Note Ref <i>(if applicable)</i>	
Comments	



11 Declarations of Conformity

The SDA system complies with the consolidated Environmental requirements of IACS E10: 2006, EN 60945: 2002 and the major maritime class society requirements.

This SDA system complies with the consolidated Electromagnetic Compatibility (EMC) requirements of IACS E10: 2006, and the major maritime class society requirements.

The SDA system complies to IMCA DO23:2000 and DO24:2001 design guidance notes.

This SDA system complies with the requirements of the Electromagnetic Compatibility (EMC) Directive 2004/108/EC

