

REPAIR KIT FOR 415 REGULATOR

For all models

1. Back off adjusting screw and remove cap from body using strap wrench.
2. Remove old poppet cartridge item 2 and install new one. Torque to 40 to 60 inch pounds. Use Dow 111 grease or special purpose lub on seals and threads.

For -400 and 1500 only

3. Install 2-028 body O ring and piston O ring item 13 as shown.

For - 5000 only

3. Install 2-026 O ring in body recess as shown. Replace piston item 4 and piston housing item 5 with new preassembled, prelubricated unit. **Do not use larger 2-028 O ring.**

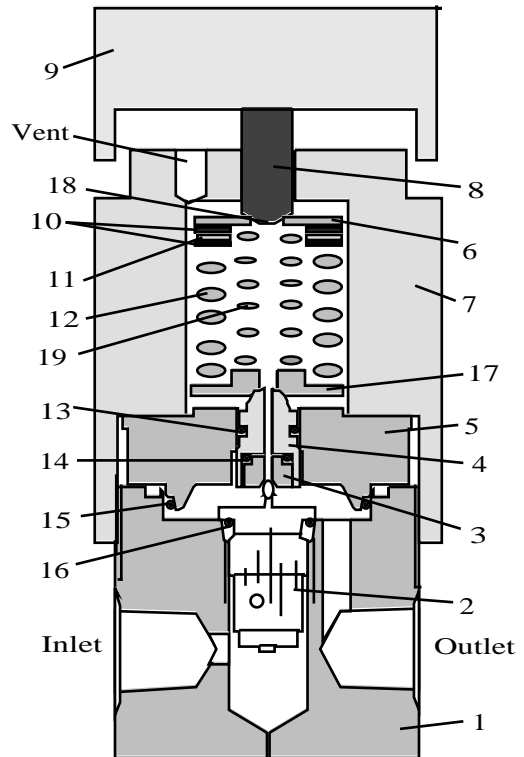

415-5000/415-6000

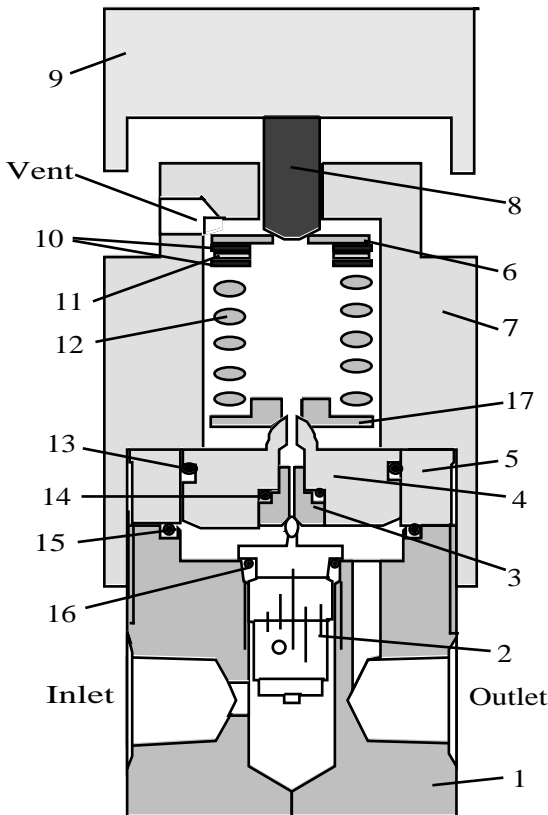

415-400

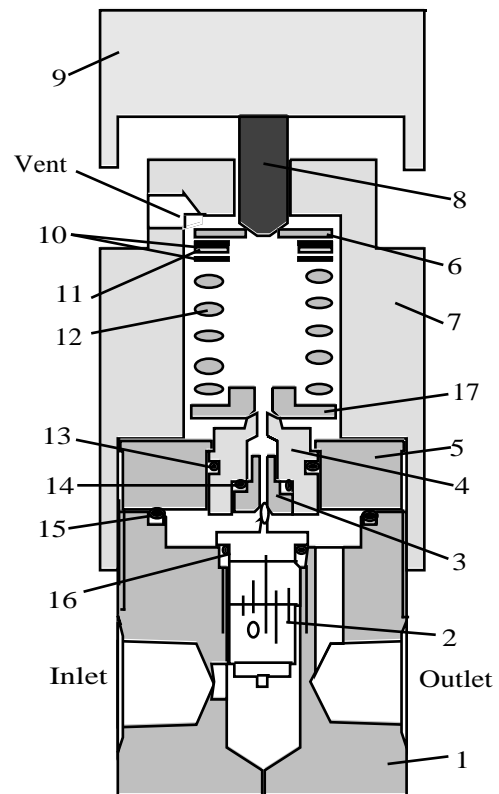

415-1500