

STANLEY®

MHP3 TRACHORSE



USER MANUAL Safety, Operation and Maintenance



© 2012 STANLEY Black & Decker, Inc.
New Britain, CT 06053
U.S.A.
68589 12/2020 Ver. 20

TABLE OF CONTENTS

SAFETY SYMBOLS.....	4
SAFETY PRECAUTIONS	5
TOOL STICKERS & TAGS	7
HOSE TYPES	8
HOSE RECOMMENDATIONS.....	9
HTMA / EHTMA REQUIREMENTS	10
HOSE & FITTING CONNECTIONS.....	11
OPERATION	12
TROUBLESHOOTING	19
FILTERS	21
ACCESSORIES	21
SPECIFICATIONS	21
MHP3 MAJOR ASSEMBLY ILLUSTRATION	24
MHP3 PARTS LIST—MAJOR ASSEMBLY	25
HOSE & FITTING ILLUSTRATION	26
MHP3 PARTS LIST - HOSE & FITTING.....	27
MHP3 SCHEMATIC	28
FRAME ILLUSTRATION	29
ENGINE ILLUSTRATION - BACK	30
ENGINE ILLUSTRATION - FRONT.....	31
ENGINE ILLUSTRATION - BASE.....	32

IMPORTANT

To fill out a product warranty validation form, and for information on your warranty, visit www.stanleyinfrastructure.com and select the Company tab > Warranty.

Note: The warranty validation record must be submitted to validate the warranty.

SERVICING: This manual contains safety, operation and routine maintenance instructions. STANLEY Infrastructure recommends that servicing of hydraulic tools, other than routine maintenance, must be performed by an authorized and certified dealer. Please read the following warning.

⚠ WARNING

SERIOUS INJURY OR DEATH COULD RESULT FROM THE IMPROPER REPAIR OR SERVICE OF THIS TOOL.

REPAIRS AND / OR SERVICE TO THIS TOOL MUST ONLY BE DONE BY AN AUTHORIZED AND CERTIFIED DEALER.

For the nearest certified dealer, call STANLEY Infrastructure at (503) 659-5660 and ask for a Customer Service Representative.

SAFETY PRECAUTIONS

Tool operators and maintenance personnel must always comply with the safety precautions given in this manual and on the stickers and tags attached to the machine.

These precautions are given for your safety. Review them carefully before operating the machine and before performing general maintenance or service.

Supervising personnel should develop additional precautions relating to the specific work area and local safety regulations. Place the added precautions in the space provided in this manual.

If you have not read this manual and the engine owners manual, you are not ready to operate the MHP3. Read and understand this manual and any stickers and tags attached to the machine before operation. Failure to do so can result in equipment damage, personal injury, or death.



- Operate the machine in a work area **WITHOUT BYSTANDERS**. The operator must be familiar with all prohibited work areas such as excessive slopes and dangerous terrain conditions.
- **DO NOT** operate the machine **ACROSS** excessive slopes or unstable terrain where “tip over” is a hazard.
- **DO NOT** operate the machine in confined areas where there may be a risk of crushing the operator between the machine and another object.
- **DO NOT OPERATE THE MHP3 TRACHORSE IN ENCLOSED SPACES**. Inhalation of engine exhaust can be fatal.
- **DO NOT WEAR LOOSE CLOTHING** that can get entangled in the working parts of the machine or hydraulic tools.
- **DO NOT** add fuel to the machine while it is running or still hot.
- **DO NOT** operate the machine if a fuel odor is present.
- **DO NOT** operate the machine within 3.3 ft./1 m of buildings, obstructions, or flammable objects.
- Allow the engine to cool before storing the machine in an enclosure.
- **DO NOT RIDE ON, OR ALLOW ANYONE ELSE TO RIDE ON, THE MACHINE AT ANY TIME.**
- Establish a training program for all operators to ensure safe operation.
- **DO NOT** operate the machine unless thoroughly trained or under the supervision of an instructor.
- Always wear safety equipment such as goggles, ear protection, head protection, respiratory protection and safety shoes at all times when operating the MHP3 TracHorse and connected hydraulic tools.
- **DO NOT** inspect or clean the machine while the engine is running. Accidental engagement of the machine can cause serious injury or death.
- Wear a homologated respirator when cutting or breaking masonry, concrete, asbestos and other materials that produce dust.
- The hydraulic circuit control switch must be in the “OFF” position when coupling or uncoupling hydraulic tools. Wipe all couplers clean before connecting. Use only lint-free cloths. Failure to do so may result in damage to the quick couplers and may cause overheating of the hydraulic system.
- Before operating hydraulic tools, read and understand the operation manual furnished with the tool.
- **DO NOT** operate a damaged or improperly adjusted, machine. **DO NOT** operate with guards removed.
- **DO NOT** weld or cut with an acetylene torch any surface or component of the equipment. Consult STANLEY before performing any welding or acetylene cutting of the equipment.
- Prevent possible personal injury or equipment damage by having all repair, maintenance and service performed only by authorized and properly trained personnel.
- **DO NOT** exceed the rated limits of the equipment or use the equipment for applications beyond its design capacity.
- Always keep critical markings, such as labels and warning stickers, legible.
- Always replace parts with replacement parts recommended by STANLEY.
- Keep all body parts away from working parts of the TracHorse.
- Be aware of surrounding hazards. Noise created by the TracHorse and the tools it operates may mask early indications of approaching hazards.
- Only use the TracHorse in well-ventilated areas. **DO NOT** operate in explosive atmospheres, in closed environments or near flammable substances.

SAFETY PRECAUTIONS

- Always be well-rested and mentally alert when operating the TracHorse and tools. **DO NOT** operate if affected by medications, drugs or alcohol.
- Keep clear of hot engine and exhaust parts.
- **DO NOT** use flammable solvents around the engine.
- **DO NOT** reverse tool rotation by changing fluid flow direction.
- Always use hose and fittings rated for 2500 psi/172 bar with a 4-to-1 safety factor. Be sure all hose connections are tight.
- Be sure all hoses are correct for current flow direction to and from the tool being used.
- **DO NOT** inspect hoses and fittings for leaks by using bare hands. “Pin-hole” leaks can penetrate the skin.
- **DO NOT** operate tools if oil temperature exceeds 140 °F/60 °C. Operation at high temperatures can cause higher than normal temperatures at the tool ,which can result in operator discomfort.
- Disconnect the battery before servicing any electrical components. Electrocution or burns could result from improper contact.
- When using pressure cleaning equipment, do not aim the jet directly at electrical components. Make sure these components are covered or protected. Do not place the water jet directly in the air filter, exhaust or air intake ports of the engine.

TOOL STICKERS & TAGS

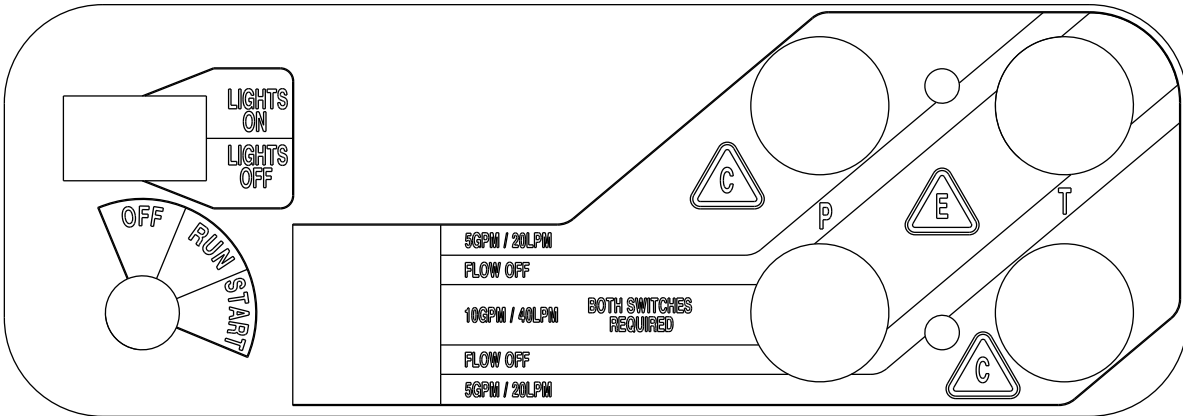

80885 Dual Circuit Decal



74759 Dash Decal



84815 Emission Control Decal

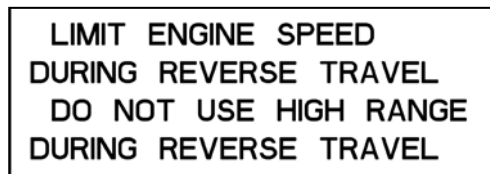

68334
Limit Engine Speed Sticker

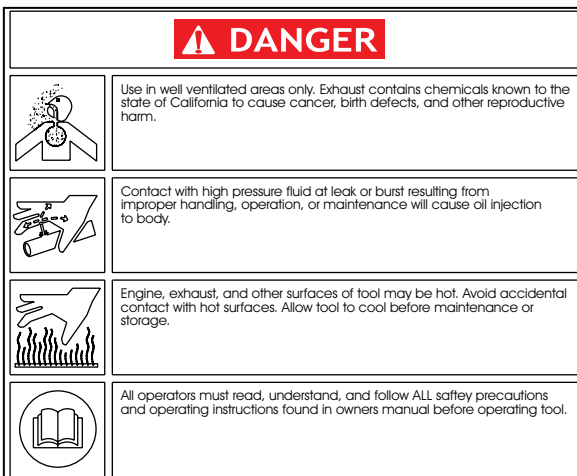

59126
Dash Sticker (Closer View)



47352 Lift Point Sticker

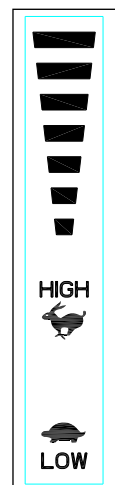

68335 Throttle Sticker

HOSE TYPES

The rated working pressure of the hydraulic hose must be equal to or higher than the relief valve setting on the hydraulic system. There are three types of hydraulic hose that meet this requirement and are authorized for use with STANLEY hydraulic tools. They are:

Certified non-conductive — constructed of thermoplastic or synthetic rubber inner tube, synthetic fiber braid reinforcement, and weather resistant thermoplastic or synthetic rubber cover. *Hose labeled **certified non-conductive** is the only hose authorized for use near electrical conductors.*

Wire-braided (conductive) — constructed of synthetic rubber inner tube, single or double wire braid reinforcement, and weather resistant synthetic rubber cover. *This hose is **conductive** and must never be used near electrical conductors.*

Fabric-braided (not certified or labeled non-conductive) — constructed of thermoplastic or synthetic rubber inner tube, synthetic fiber braid reinforcement, and weather resistant thermoplastic or synthetic rubber cover. *This hose is **not certified non-conductive** and must never be used near electrical conductors.*

HOSE SAFETY TAGS

To help ensure your safety, the following DANGER tags are attached to all hose purchased from STANLEY. DO NOT REMOVE THESE TAGS.

If the information on a tag is illegible because of wear or damage, replace the tag immediately. A new tag may be obtained from your STANLEY Distributor.

THE TAG SHOWN BELOW IS ATTACHED TO “CERTIFIED NON-CONDUCTIVE” HOSE

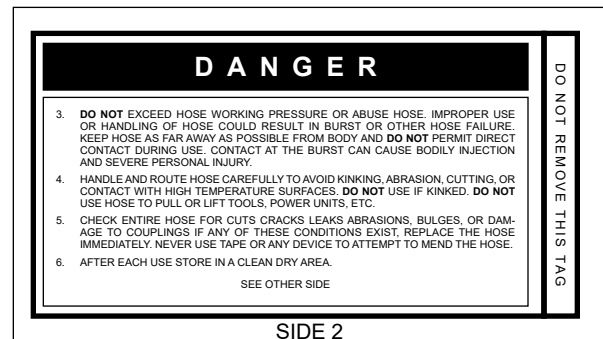
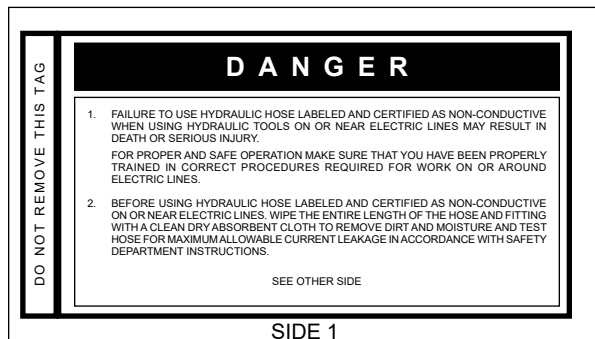

(Shown smaller than actual size)

THE TAG SHOWN BELOW IS ATTACHED TO “CONDUCTIVE” HOSE.

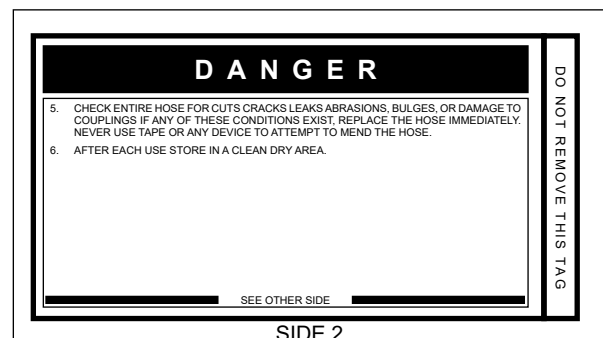
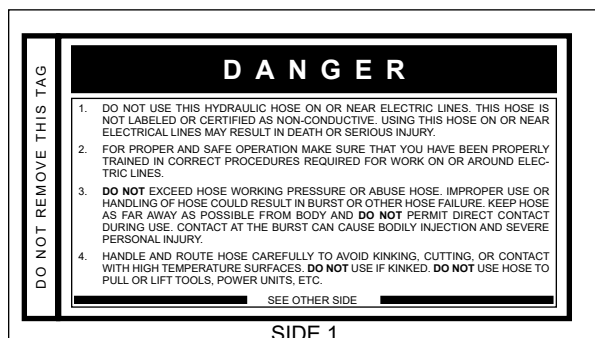

(Shown smaller than actual size)

HOSE RECOMMENDATIONS

Tool to Hydraulic Circuit Hose Recommendations

The chart to the right shows recommended minimum hose diameters for various hose lengths based on gallons per minute (GPM)/liters per minute (LPM). These recommendations are intended to keep return line pressure (back pressure) to a minimum acceptable level to ensure maximum tool performance.

This chart is intended to be used for hydraulic tool applications only based on STANLEY tool operating requirements and should not be used for any other applications.

All hydraulic hose must have at least a rated minimum working pressure equal to the maximum hydraulic system relief valve setting.

All hydraulic hose must meet or exceed specifications as set forth by SAE J517.

Oil Flow		Hose Lengths		Inside Diameter		USE (Press/Return)	Min. Working Pressure	
GPM	LPM	FEET	METERS	INCH	MM		PSI	BAR
Certified Non-Conductive Hose - Fiber Braid - for Utility Bucket Trucks								
4-9	15-34	up to 10	up to 3	3/8	10	Both	2250	155
Conductive Hose - Wire Braid or Fiber Braid - DO NOT USE NEAR ELECTRICAL CONDUCTORS								
4-6	15-23	up to 25	up to 7.5	3/8	10	Both	2500	175
4-6	15-23	26-100	7.5-30	1/2	13	Both	2500	175
5-10.5	19-40	up to 50	up to 15	1/2	13	Both	2500	175
5-10.5	19-40	51-100	15-30	5/8	16	Both	2500	175
5-10.5	19-40	100-300	30-90	5/8	16	Pressure	2500	175
10-13	38-49	up to 50	up to 15	3/4	19	Return	2500	175
10-13	38-49	51-100	15-30	5/8	16	Both	2500	175
10-13	38-49	100-200	30-60	3/4	19	Pressure	2500	175
13-16	49-60	up to 25	up to 8	1	25.4	Return	2500	175
13-16	49-60	26-100	8-30	5/8	16	Pressure	2500	175
13-16	49-60	26-100	8-30	3/4	19	Return	2500	175
13-16	49-60	26-100	8-30	3/4	19	Pressure	2500	175
13-16	49-60	26-100	8-30	1	25.4	Return	2500	175

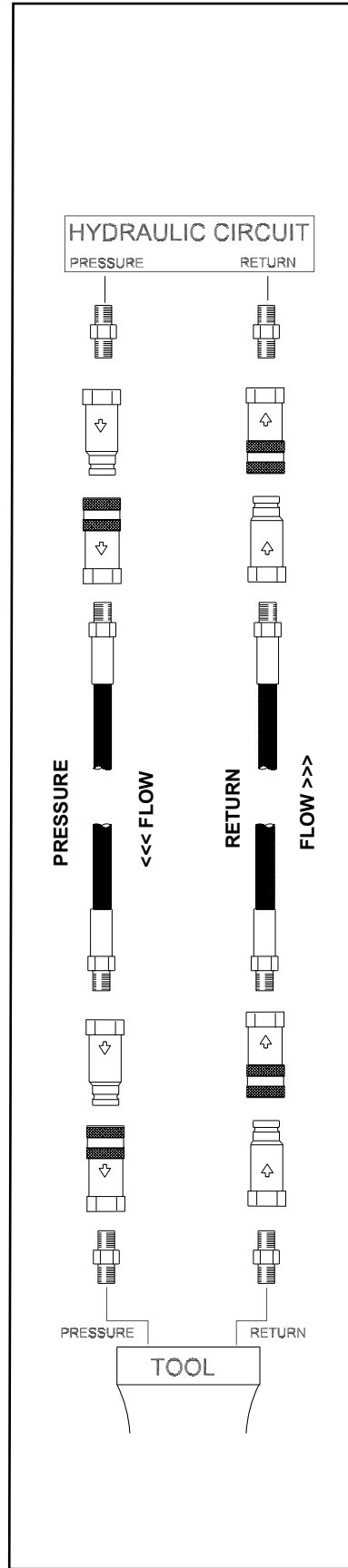

Figure 1. Typical Hose Connections

HTMA / EHTMA REQUIREMENTS

HTMA / EHTMA REQUIREMENTS

TOOL TYPE

HTMA HYDRAULIC SYSTEM REQUIREMENTS	TYPE I	TYPE II	TYPE RR	TYPE III
Flow range	4-6 GPM (15-23 LPM)	7-9 GPM (26-34 LPM)	9-10.5 GPM (34-40 LPM)	11-13 GPM (42-49 LPM)
Nominal operating pressure (At the power supply outlet)	1500 psi (103 bar)	1500 psi (103 bar)	1500 psi (103 bar)	1500 psi (103 bar)
System relief valve setting (At the power supply outlet)	2100-2250 psi (145-155 bar)	2100-2250 psi (145-155 bar)	2200-2300 psi (152-159 bar)	2100-2250 psi (145-155 bar)
Maximum back pressure (At tool end of the return hose)	250 psi (17 bar)	250 psi (17 bar)	250 psi (17 bar)	250 psi (17 bar)
Measured at a max fluid viscosity of: (At minimum operating temperature)	400 ssu* (82 centistokes)	400 ssu* (82 centistokes)	400 ssu* (82 centistokes)	400 ssu* (82 centistokes)
Temperature: Sufficient heat rejection capacity to limit maximum fluid temperature to: (At maximum expected ambient temperature)	140° F (60° C)	140° F (60° C)	140° F (60° C)	140° F (60° C)
Minimum cooling capacity at a temperature difference of between ambient and fluid temps	3 hp (2.24 kW) 40° F (22° C)	5 hp (3.73 kW) 40° F (22° C)	6 hp (5.22 kW) 40° F (22° C)	7 hp (4.47 kW) 40° F (22° C)
Note: Do not operate the tool at oil temperatures above 140° F (60° C). Operation at higher temperatures can cause operator discomfort at the tool.				
Filter minimum full-flow filtration Sized for flow of at least: (For cold temp startup and maximum dirt-holding capacity)	25 microns 30 GPM (114 LPM)	25 microns 30 GPM (114 LPM)	25 microns 30 GPM (114 LPM)	25 microns 30 GPM (114 LPM)
Hydraulic fluid, petroleum based (premium grade, anti- wear, non-conductive) Viscosity (at minimum and maximum operating temps)	100-400 ssu (20-82 centistokes)	100-400 ssu (20-82 centistokes)	100-400 ssu (20-82 centistokes)	100-400 ssu (20-82 centistokes)
Note: When choosing hydraulic fluid, the expected oil temperature extremes that will be experienced in service determine the most suitable temperature viscosity characteristics. Hydraulic fluids with a viscosity index over 140 will meet the requirements over a wide range of operating temperatures.				
*SSU = Saybolt Seconds Universal				

CLASSIFICATION

EHTMA HYDRAULIC SYSTEM REQUIREMENTS					
Flow range	3.5-4.3 GPM (13.5-16.5 LPM)	4.7-5.8 GPM (18-22 LPM)	7.1-8.7 GPM (27-33 LPM)	9.5-11.6 GPM (36-44 LPM)	11.8-14.5 GPM (45-55 LPM)
Nominal operating pressure (At the power supply outlet)	1870 psi (129 bar)	1500 psi (103 bar)	1500 psi (103 bar)	1500 psi (103 bar)	1500 psi (103 bar)
System relief valve setting (At the power supply outlet)	2495 psi (172 bar)	2000 psi (138 bar)	2000 psi (138 bar)	2000 psi (138 bar)	2000 psi (138 bar)

Note: These are general hydraulic system requirements. See tool specification page for tool specific requirements.

HOSE & FITTING CONNECTIONS

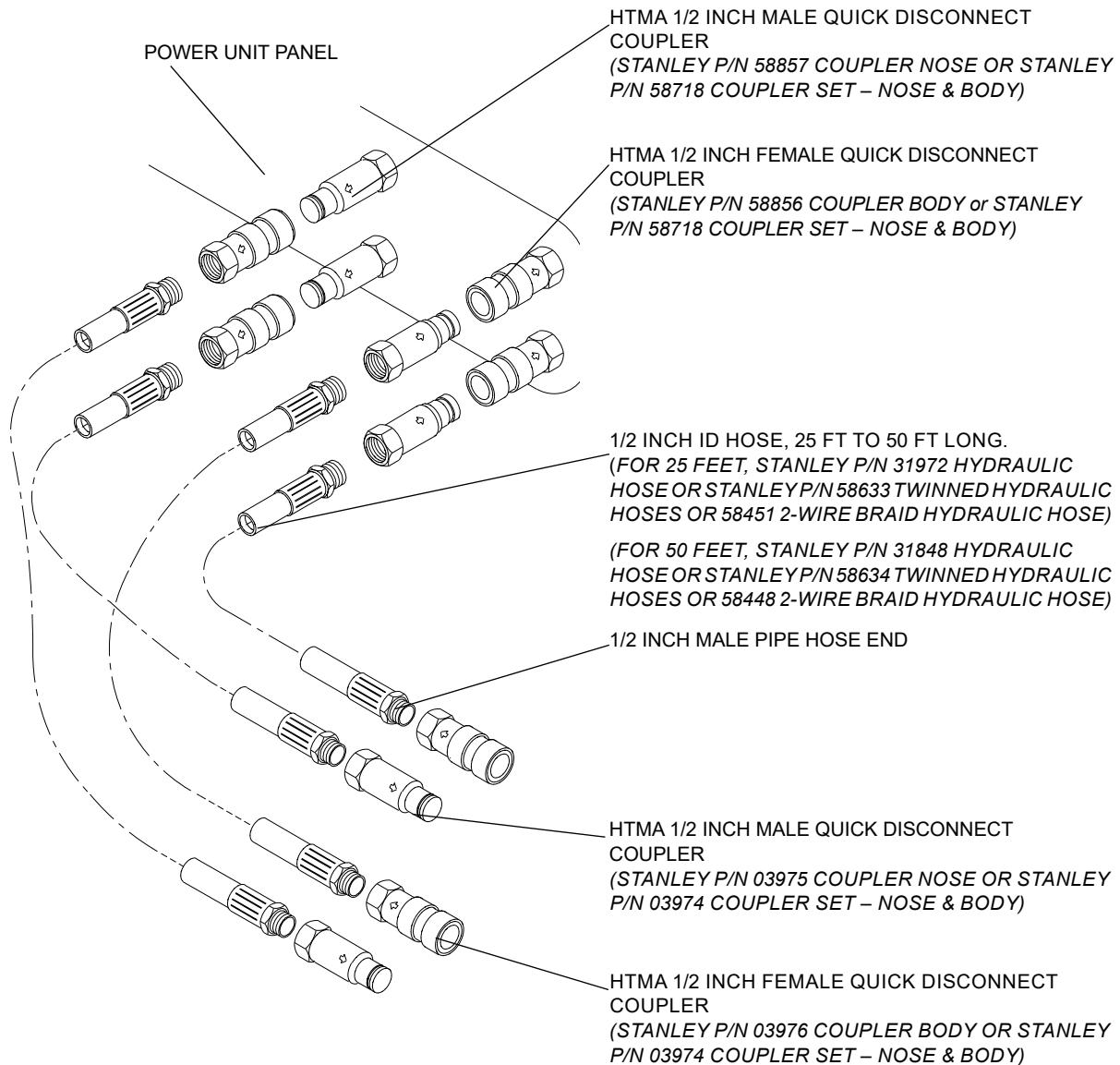

OPERATION

PREPARATION PROCEDURES

Connect the battery cables to the battery. There are no other special unpacking or assembly requirements prior to usage. Inspect to assure the equipment was not damaged in shipping, does not contain packing debris and check fluid levels as described below.

Check the TracHorse to ensure all guards are in place, all controls are functioning properly and the unit is completely assembled with no missing, damaged or loose parts or fittings.

ENGINE OIL LEVEL

Before each use, check the engine oil level. Make sure the engine oil level is at the FULL MARK on the dipstick. Do not overfill. Use detergent oil classified "For Service SE, SF, SG" as specified in the engine operating and maintenance manual.

The engine oil dipstick is located on the right side of the Honda engine.

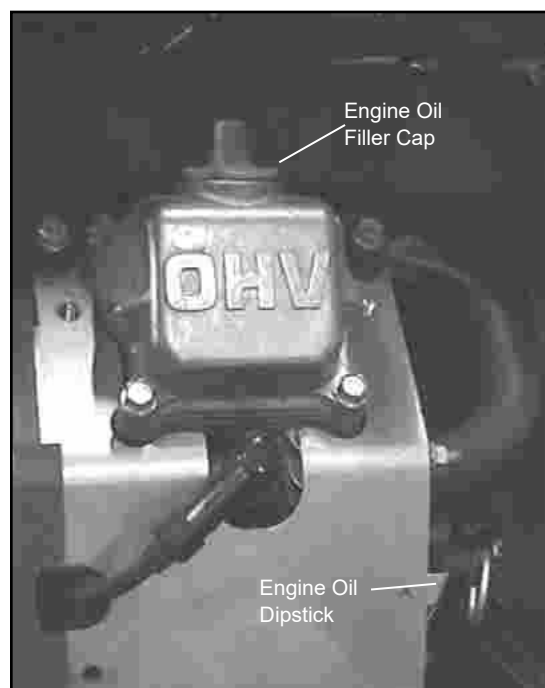

Figure 2. Honda Engine

SPARK PLUG

The power units are equipped with Honda engines, ONLY Denso J16CR-U or equivalent can be used.

ENGINE FUEL LEVEL

Check the fuel level. If low, fill with unleaded gasoline with a minimum of 85 octane.

BATTERY

The supplied 12 Volt DC battery is a non-spillable, maintenance-free battery and is fully charged.

Make sure the battery cables are tight and charging circuit functions are operating properly.

Do not charge the battery with an automotive battery charger. Charging at higher than 2 amps will damage the battery.

If the engine stalls during operation, set the ignition switch to the "OFF" position to preserve battery charge.

HYDRAULIC FLUID

Check the sight gauge in the hydraulic fluid reservoir for the proper fluid level.

NOTICE

Low hydraulic fluid indicates a leak in the hydraulic system. Inspect all hydraulic connections and hydraulic components for leaks. DO NOT use the equipment until leaks are repaired.

RECOMMENDED HYDRAULIC OILS

Below is a list of recommended oils by brand.

Brand	Biodegradable	Description
CITGO	No	Hydurance AW32
AMS Oil	No	HVH 32
Exxon Mobil	No	Univis HVI26*
Exxon Mobil	No	DTE 10 Excel
Shell	No	S2 V 32
Chevron	No	Rando HDZ 32
Conoco Phillips	No	Unax AW-WR-32
Clarion (CITGO)	Yes	Green Bio 32
Exxon Mobil	Yes	EAL 224H
Chevron	Yes	Clarity AW32
Terresolve	Yes	Envirologic 132
Shell	Yes	Naturelle HF-E-32

*Recommended for extreme cold temperatures

OPERATION

QUICK DISCONNECT COUPLERS

HTMA-approved quick-disconnect couplings are installed to hydraulic hoses so that the direction of oil flow is always from the male to the female quick disconnect, as shown on page 9. Quick disconnect couplings and hose fittings are selected so that additional fittings such as reducer or adapter fittings are not required.

If adapter fittings are used, they must be approved steel hydraulic fittings meeting a minimum operating pressure rating of 2500 psi/172 bar. Do not use galvanized pipe fittings or black pipe fittings.

Use thread tape or pipe joint compound when installing quick disconnect couplings to hose or tool fittings. Follow the instructions furnished with the selected thread sealant. **DO NOT OVERTIGHTEN THE FITTINGS.**

OPERATING THE TOOL CIRCUIT

Facing the panel, the male quick disconnect fittings are the PRESSURE FLUID OUT fitting. The female quick disconnect fittings are the RETURN FLUID IN (RETURN) fitting.

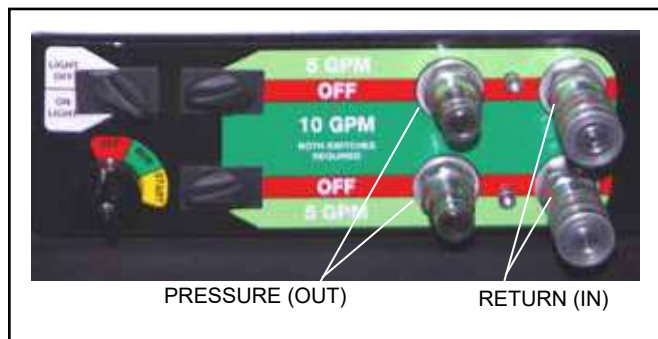

The “Dual Circuit” control panel contains connections for two 5 GPM tool circuits. In addition, the two circuits may be combined into one 10 GPM tool circuit.

1. If using one 5 GPM tool circuit, select either the upper or lower circuit and connect the PRESSURE FLUID OUT hose to the male coupler and connect the RETURN FLUID IN (RETURN) to the female coupler next to it. Connect the other ends of the hoses to the tool.

If using both 5 GPM tool circuits, connect PRESSURE FLUID OUT hoses to the male couplers and connect the RETURN FLUID IN (RETURN) hoses to the female couplers. Connect the other ends of the hoses to the tools.

NOTE: Before starting the engine make sure the tool circuit switches are in the “OFF” position.

The power unit will not start if the tool selector switches are not in the “OFF” position.

2. Ensure the throttle control is pulled back to the idle position.



3. Ensure the tool circuit switches are in the “OFF” position.
4. Pull the choke out until it stops.
5. Turn the ignition switch clockwise to begin cranking the engine. Use short starting cycles (15 seconds per minute) to prolong starter life. Extended cranking can damage the starter motor.
6. After the engine starts, allow it to warm-up for a few seconds before moving the choke. Move the choke inward in small steps to allow the engine to accept small changes in speed and load. Continue moving the choke in until it is fully off and the engine is running smoothly.
7. Place the throttle at the maximum setting.
8. Position each tool circuit switch to 5 GPM. The tools can now be used.
9. Reverse the above procedure to stop using the tools.

DUAL CIRCUIT COMBINED FOR 10 GPM

1. To combine the two 5 GPM tool circuits into one 10 GPM tool circuit, connect the PRESSURE FLUID OUT hose to either one of the two male couplers. Connect the RETURN FLUID IN (RETURN) hose to either one of the two female couplers. Connect the other ends of the hoses to the tool.
2. Ensure the throttle control is pulled fully back to the idle position.
3. Ensure the tool circuit switches are in the “OFF” position.
4. Pull the choke out until it stops.

OPERATION

5. Turn the ignition switch clockwise to begin cranking the engine. Use short starting cycles (15 seconds per minute) to prolong starter life. Extended cranking can damage the starter motor.
6. After the engine starts, allow it to warm-up for a few seconds before moving the choke. Move the choke inward in small steps to allow the engine to accept small changes in speed and load. Continue moving the choke in until it is fully off and the engine is running smoothly.
7. Place the throttle at the maximum setting.
8. Position each tool circuit switch to 10 GPM. The tool can now be used.
9. Reverse the above procedure to stop using the tool.

COLD WEATHER STARTUP

Hydraulic fluids are thicker in cold weather. Therefore, it is recommended that the engine be run at low idle long enough to bring the hydraulic fluid temperature up to a minimum of 50 °F/10 °C.

If the tools and tool hoses are cold, it is recommended to allow hydraulic fluid to circulate through the tool hoses until warm before using the tools.

SHUTDOWN

1. Ensure each flow selector switch is in the “OFF” position.
2. Move the throttle control to idle.
3. Allow the engine to idle for approximately one minute and move the Ignition Switch to the “OFF” position.

NOTICE

If the engine runs out of gas or dies during operation and the ignition switch is left in the “ON” or “RUN” position, this could drain the battery. Make sure the ignition switch is returned to the “OFF” position.

ADJUSTING THROTTLE FOR VARIOUS TYPES OF WORK

⚠ WARNING

When first learning to operate the TracHorse, position the throttle to the “SLOW” position. More experienced operators may use higher throttle settings.

FORWARD TRAVEL

The throttle can be positioned anywhere between slow and fast for traveling forward, depending on the weight of the load being carried. Heavy loads will require higher throttle settings and low range in order for the engine to provide enough power to move the load.

A switch mounted below the throttle control provides two-speed (FAST & SLOW) operation.



REVERSE TRAVEL

⚠ WARNING

DO NOT attempt to travel in reverse with the throttle positioned above **SLOW**. This may result in loss of control and result in injury or death to the operator.

Always position the throttle to a slow position for reverse travel to permit increased control and safety.

Always switch the two-speed control to “LOW” speed operation when moving in reverse.

OPERATION

SLOPE OPERATION

⚠ WARNING

DO NOT operate the machine on slopes exceeding 60 percent (30°) in the travel direction or across slopes exceeding 45 percent (24°).

Depending on the load carried in the bed, it may be preferable to back up steep slopes.

If traversing over large obstructions such as railroad rail or curbs, travel at an angle (45 degrees) to the obstruction. In some cases it may be easier to back over them.

Avoid turning on slopes. If you must turn, turn slowly downhill, if possible.

DO NOT operate the machine near drop-offs, ditches or embankments. The machine could suddenly turn over if a track goes over the edge or if an edge collapses.

DO NOT try to stabilize the machine if it is tipping over. Let go of the machine and get out of its way.

TRAVELING FORWARD OR REVERSE



Track Steering Controls

Forward Travel

TO MOVE FORWARD IN A STRAIGHT LINE: Move both the left and right track controls forward at the same time.

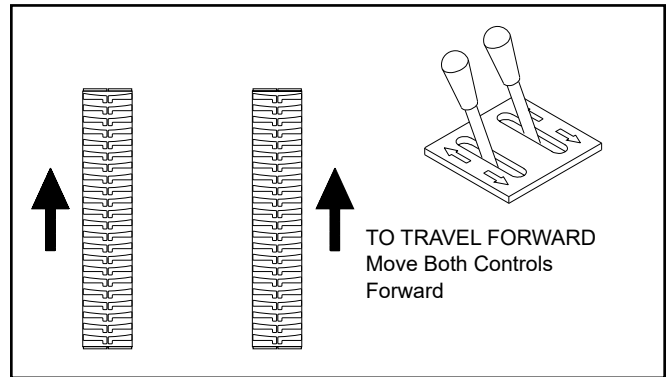

TO TURN LEFT WHILE MOVING FORWARD: Release the left track control while pushing forward on the right track control. Resume pushing forward on the left track control to move forward in a straight line.

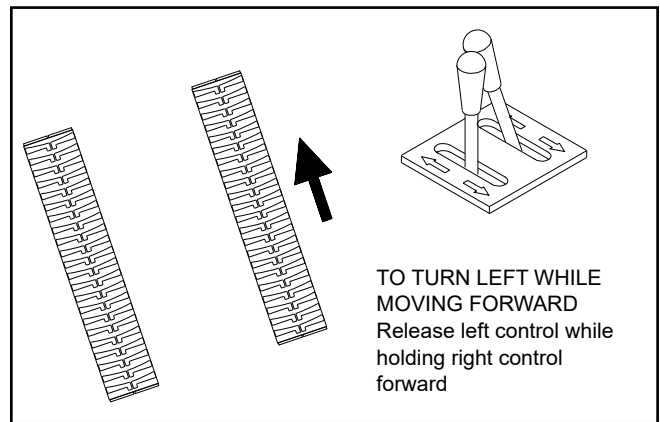

TO TURN RIGHT WHILE MOVING FORWARD: Release the right track control while pushing forward on the left track control. Resume pushing forward on the right track control to move forward in a straight line.

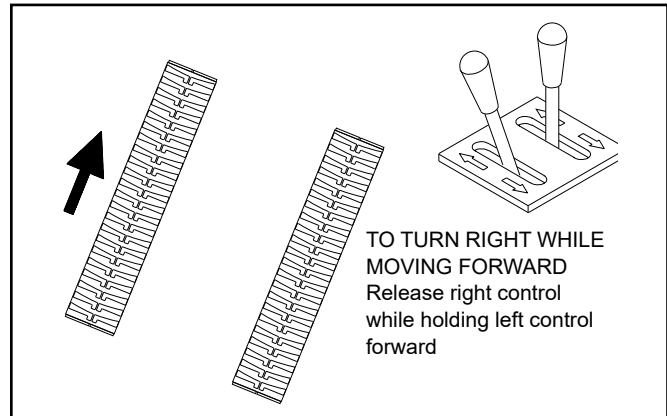

Reverse Travel

OPERATION

⚠ WARNING

DO NOT attempt to travel in reverse with the throttle positioned above **SLOW**. This may result in loss of control and result in injury or death to the operator.

TO MOVE BACKWARDS IN A STRAIGHT LINE: Move both the left and right track controls backward at the same time.

TO TURN LEFT WHILE MOVING BACKWARD: Release the left track control while pulling backward on the right track control. Resume pulling backward on the left track control to move backward in a straight line.

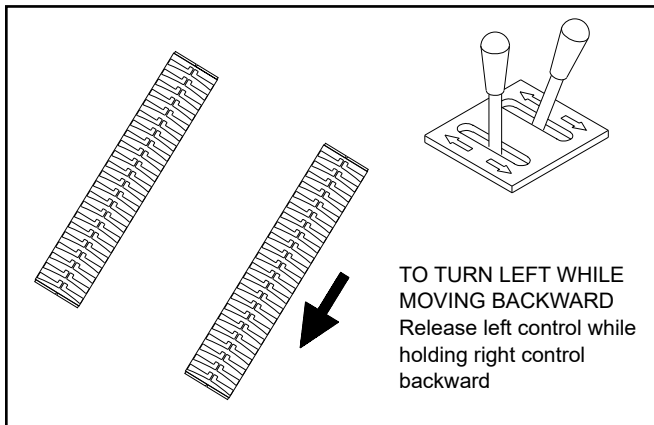

TO TURN RIGHT WHILE MOVING BACKWARD: Release the right track control while pulling backward on the left track control. Resume pulling backward on the right track control to move backward in a straight line.

Turning From a Stop

TO TURN LEFT FROM A STOP: Move the right track control forward moving the left track control backward. At the same time will increase the turning rate.

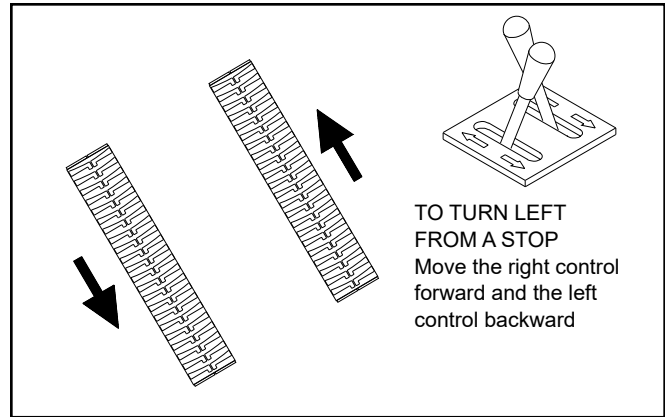

TO TURN RIGHT FROM A STOP: Move the left track control forward moving the right track control backward. At the same time will increase the turning rate.

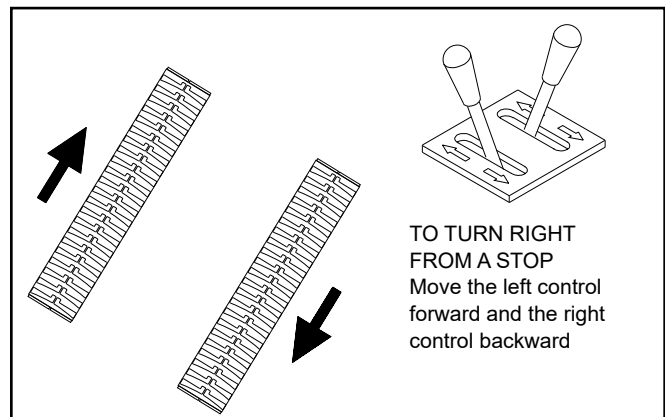

LOADING AND UNLOADING

1. Use loading ramps or a loading dock to load and unload the machine. Ensure loading ramps are strong enough to support the load. When using ramps, do not exceed a 15 degree incline (27 percent).

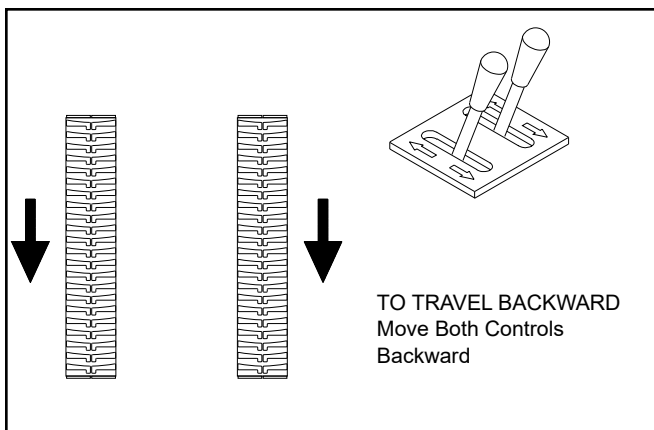

OPERATION

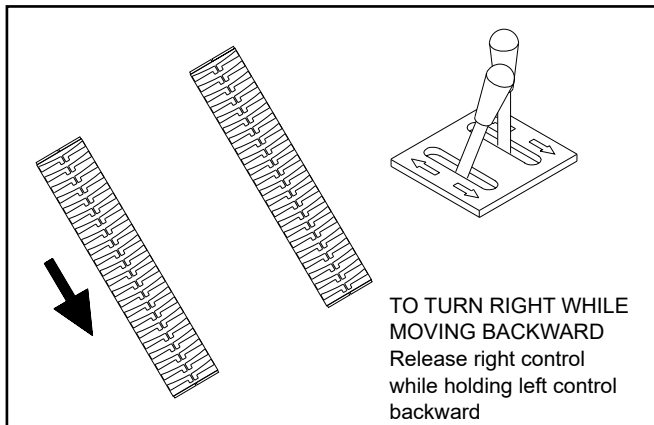

DANGER

Loading and unloading of any type of machine is dangerous. Never attempt to load or unload the machine without loading ramps or a loading dock.

Loading ramps must be strong enough, have a low angle and correct height. Load and unload the machine on a level surface. Never attempt to load or unload the machine if the ramp incline exceeds 15 degrees. Failure to follow these instructions may result in serious injury or death.

2. Ensure the wheels of the trailer and the tow vehicle have been chocked front and rear.
3. Use the **SLOW** throttle setting when loading or unloading. Always switch the two-speed control to **LOW** speed operation when moving in reverse.
4. Drive the machine onto the trailer backwards (engine first). This will help prevent instability and keeps the operator “up hill” from the machine during loading and unloading.
5. After loading, place chocks at the front and rear of the tracks.

LIFTING

The unloaded TracHorse can be lifted using the single central lift point. Some safety rules may require 3-point lifting. (Center lift point plus 2-points on the forward side of the rails.)

If lifting with any items in the bed, a 3-point lift is required. (A 3-point lifting sling is available, refer to “Accessories” on page 21.)

TRANSPORTING

1. Read the instructions for loading and unloading in this section.
2. Use chains and binders to secure the load to the trailer.

ROUTINE MAINTENANCE

Good maintenance practices will keep the machine on the job and increase its service life.

A very important maintenance practice is to keep the hydraulic fluid clean at all times. Contaminated hydraulic fluid causes rapid wear and/or failure of internal parts.

Follow the maintenance instructions contained in the engine owners manual.

ENGINE MAINTENANCE

Follow the maintenance schedule and general maintenance instructions in the engine owners manual, furnished with the power unit. Normal maintenance includes:

- Service foam air pre-cleaner every 25 hours of operation.
- Service air paper cartridge every 100 hours of operation.
- Replace in-line fuel filter every 100-300 hours or sooner if required.
- Replace spark plugs every 100 hours of operation.
- Change engine oil after first 5 hours of operation, then after every 50 hours of operation. If engine has been operating under heavy load or in high ambient temperature, change the oil every 25 hours of operation.
- Change oil filter when engine oil is changed.
- Check oil level daily.
- Remove dirt and debris from engine with a cloth or brush daily. Do not use water spray.
- Clean air cooling system every 100 hours of operation.

HYDRAULIC SYSTEM MAINTENANCE

Observe the following for maximum performance and service life from the hydraulic system.

- Always keep hydraulic system and fluids clean.
- Keep water out of hydraulic fluid (see “Removing Condensed Moisture From Hydraulic Fluid” on page 18).

OPERATION

- Keep air out of hydraulic lines. Hydraulic system overheating and foam at the hydraulic tank breather indicate air is present in the lines. Keep all suction line fittings and clamps tight.
- Hydraulic system wear is noted by increased heat during tool operation, reduced tool performance and eventual system breakdown.
- Operate with the fluid temperature at 50–140 °F/ 10–60 °C for improved seal and hose life, and maximum efficiency.

FILLING THE RESERVOIR

Make sure the engine is stopped before opening the filler cap. Fill slowly with the recommended fluid. Add fluid as needed. Secure the filler cap before restarting the engine. Refer to the hydraulic fluid page in this section for determining correct fluid level.

- Change the hydraulic filter element every 200 hours of operation. Change more often if cold, moist or dusty conditions exist.
- Check oil cooler for debris. Remove debris with air pressure.

REMOVING CONDENSED MOISTURE FROM HYDRAULIC FLUID

Condensation is a frequent problem with mobile hydraulic circuits. This condition occurs in moist or cold climates. When warm air in the hydraulic tank draws moisture from the cooler air outside, water accumulates in the tank.

- Check hydraulic fluid level daily. Add fluid per specifications in this manual (see “HYDRAULIC FLUID” ON PAGE 12).
- Remove condensed moisture from the hydraulic fluid by pumping the hydraulic fluid into a 5 gal/20l container through the pressure hose. Make sure the engine is at idle when performing this procedure. When the hydraulic reservoir is empty, turn the engine **OFF** immediately.
- Allow the fluid to sit long enough for the water to settle to the bottom of the container. Slowly pour the fluid back into the hydraulic tank, avoiding the water at the bottom of the container.

CHECKING SUCTION HOSE

Make sure the suction hose (from the hydraulic tank to the pump inlet) is not kinked and is clamped securely. This reduces the risk of pump cavitation and sucking air into the system. All pump fittings should be tight.

CHECKING HYDRAULIC LINES AND

FITTINGS

Check hydraulic lines and fittings for leaks, kinks, etc. daily. Do not use your hand to perform this check.

CLEANING THE TRACHORSE

When using pressure cleaning equipment, do not aim the jet directly at electrical components. Make sure these components are covered or protected. Do not place the water jet directly in the air filter, exhaust or air intake ports of the engine. After unit has been cleaned blow dry with air. On electrical connections, use dielectric grease on terminals.

ADJUSTING TRACK TENSION

- The track tension is adjusted with the unit lifted off the ground. Between the drive wheel and front idler wheel, there are 3 smaller rollers.
- Once the unit is lifted off the ground, adjust the track tension to achieve 3/8” to 1/2” sag below the center small roller.

TROUBLESHOOTING

If symptoms of poor performance develop, the following chart can be used as a guide to correct the problem.

When diagnosing faults in operation of the machine or tool, always check that the hydraulic power source is supplying the correct hydraulic flow and pressure as listed in the table. Use a flowmeter known to be accurate. Check the flow with the hydraulic oil temperature at least 80 °F/27 °C.

Problem	Cause	Solution
Machine will not start.	Fuel filter plugged.	Replace fuel filter.
	No fuel.	Add fuel.
	Defective spark plugs.	Remove plugs, check gap, clean or replace.
	Tool circuit switch is on.	Turn tool circuit switch off.
	Battery not connected.	Attach battery cables, check wires.
	Weak battery.	Test battery, charge or replace.
	Solenoid not working.	Check solenoid operation and electrical connections.
Hydraulic fluid blowing out of fluid reservoir vent.	Hydraulic tank overfilled.	Correct fluid level.
	Pump suction leak.	Check suction connections.
Machine stalls when track controls are pushed.	Not enough throttle.	Increase throttle setting/use low range.
	Heavy load.	Increase throttle setting/use low range.
	Over maximum pay load.	Max load 1000 lb/454 kg.
Hydraulic tool will not operate.	Tool circuit switch is OFF .	Turn tool circuit switch ON .
	Not enough throttle.	Move throttle to FAST position.
	Incorrect tool/hose connection.	Check for correct connections.
	Flow selector switch not switched ON .	Check that the flow selector switch is set to 5 or 10 GPM.
	Incorrect hose connection to tool.	Make sure the tool hose circuit goes from left (pressure) fitting to tool and back to the right fitting (return). Fluid always flows from the male to female fittings.
	Quick disconnect fittings.	Detach from hose, connect set together and check for free flow.
	Pump coupling defective.	With the engine not running: check the coupling between the pump and engine that it is engaged and is not damaged. Caution: Keep hands clear of rotating objects.
	Suction hose kinked.	Make sure suction hose from fluid reservoir to pump inlet has a smooth curve.
	Solenoid not working.	Check solenoid operation and electrical connections.
	Tool is defective.	Refer to tool manual.
Relief valve defective.	Have machine serviced.	
Machine cannot be moved using hydraulic controls	Defective gear box(es)	Have machine serviced.
	One or more defective hydraulic component	Have machine serviced.
	Hydraulic fluid level low	Check for correct level.
	Pump coupling defective	Have machine serviced.
	Relief valve stuck open	Have machine serviced.

TROUBLESHOOTING

FUEL TANK

NOTE: When ordering a fuel tank or fuel tank cap **DO NOT MIX OLD STYLE TANK AND CAP WITH NEW STYLE TANK AND CAP.**

If you have a power unit and it was purchased prior to 2011 and need to replace the fuel tank or fuel tank cap, you must purchase the same tank and cap that came with your unit.

For example, if you have a power unit prior to 2011 do not purchase a new style fuel tank, your engine will not be equipped with a fuel vapor fitting.

The old style fuel cap is a vented cap, while the new style fuel cap is not a vented cap and venting is achieved thru the vapor line.

The old style fuel tank has only one fuel line coming from the tank to the engine. The new style fuel tank has two lines coming from the fuel tank to the engine, one is the fuel line and the other is a fuel vapor line.

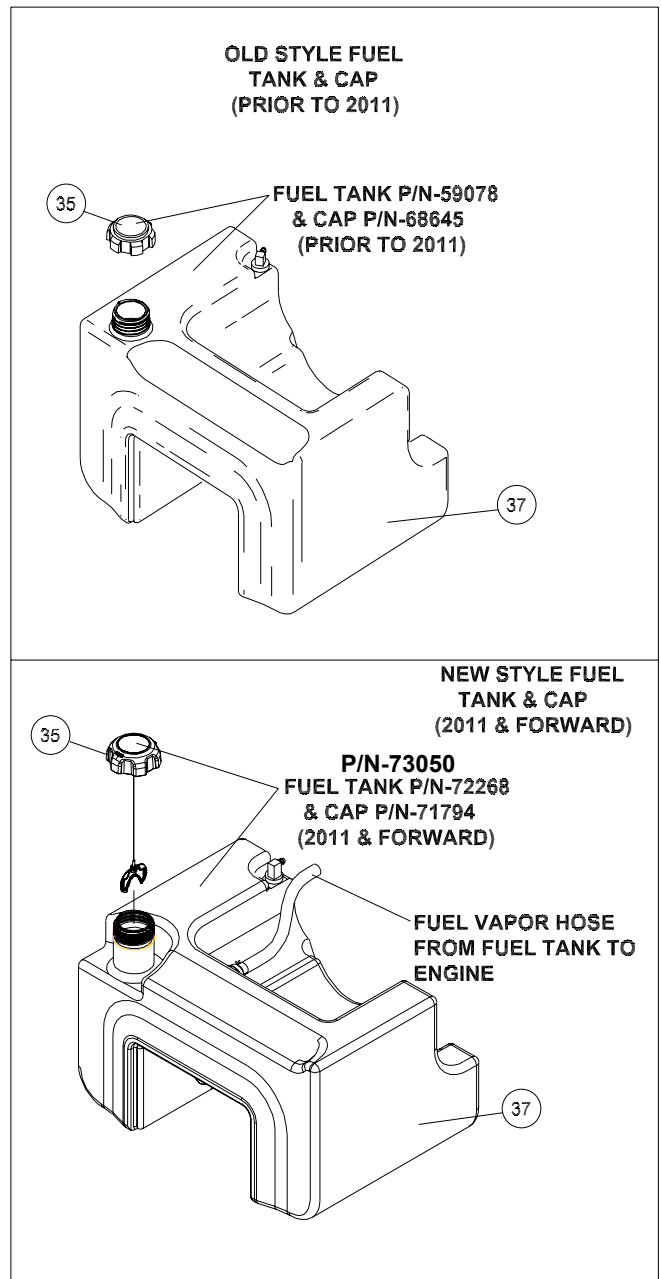

SPECIFICATIONS

Engine 20 h.p. Honda
 Fuel Capacity..... 5.5 gal / 20.8 ltr
 Fuel Type.....Unleaded Gasoline w/ 85 Octane Minimum
 Pressure Range..... 2000 psi/140 bar
 Flow Range2 ea 5 GPM/20 LPM or 10 GPM/38 LPM
 CouplersHTMA/EHTMA Flush Face Type Male & Female
 Connect Size and Type-8 SAE

Weight (Standard Trachorse)1200 lbs/544 kg
 Weight (Bed Less Trachorse).....980 lbs/445 kg

Maximum Pay Load.....1000 lbs/454 kg
 Overall Length 78 in./198 cm
 Overall Width..... 36 in./92 cm
 Overall Height..... 43 in./109 cm
 Hydraulic Oil Capacity3 Gallon/11 ltr

FILTERS

ENGINE				HYDRAULIC OIL FILTER	COMMENTS
ENGINE TYPE	OIL FILTER	AIR FILTER	FUEL FILTER		
HONDA GX630	40458	76429	76430	40408	HONDA
HONDA GX620	40458	40459	40460	40408	HONDA

ACCESSORIES

DESCRIPTION	PART NUMBER
Coupler Nose, 3/8 Port, Bruning.....	03972
Coupler Body, 3/8 Port, Bruning.....	03973
Coupler Set, 3/8 Port , Bruning (includes nose & body).....	03971
Coupler Nose, 1/2 Port, Bruning.....	03975
Coupler Body, 1/2 Port, Bruning.....	03976
Coupler Set, 1/2 Port, Bruning (includes nose & body).....	03974
Hose Assembly, 50 ft., with couplers (2 wire braid RR).....	58448
Hose Assembly, 50 ft., with couplers.....	31848
Hose Assembly, 25 ft., with couplers.....	31972
Hose Assembly, 25 ft., with couplers (2 wire braid RR).....	58451
3-Point Lift Sling.....	68358

MHP3 MAJOR ASSEMBLY ILLUSTRATION

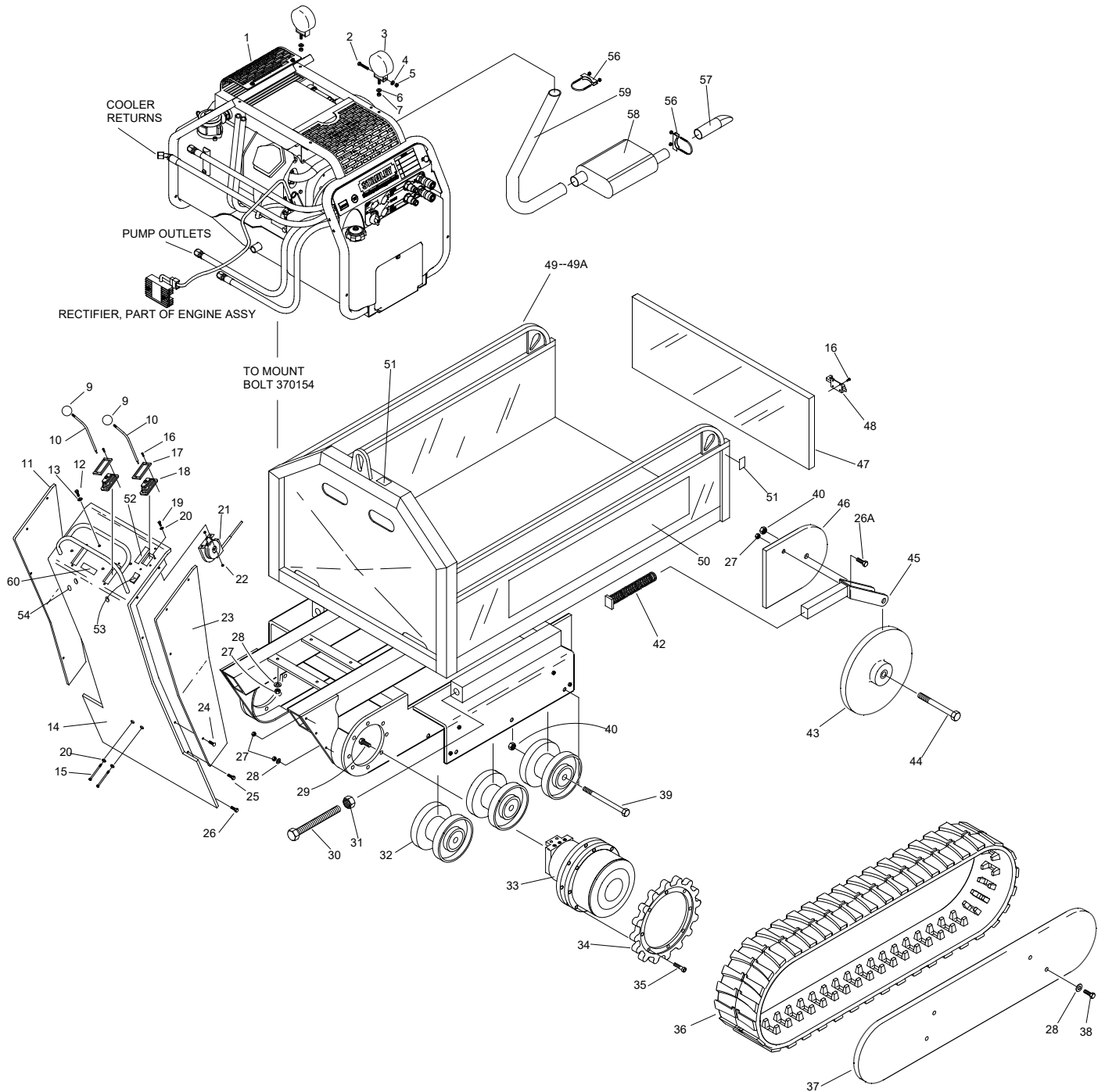

ADJUSTING TRACK TENSION

- The track tension is adjusted with the unit lifted off the ground. Between the drive wheel and front idler wheel, there are 3 smaller rollers.
- Once the unit is lifted off the ground, adjust the track tension to achieve 3/8" to 1/2" sag below the center small roller.

MHP3 PARTS LIST—MAJOR ASSEMBLY

ITEM	P/N	QTY	DESCRIPTION
1	HP210HT	1	POWER UNIT
	HP210HTB	1	POWER UNIT
2	21319	2	CAPSCREW
3	69477	2	LIGHTS – 5" MULTIPURPOSE
4	69490	2	WASHER
5	00719	4	NUT (PART OF ITEM 3)
6	04539	2	WASHER
7	69477	2	NUT (PART OF ITEM 3)
9	69488	2	KNOB
10	69753	2	VALVE HANDLE
11	69465	1	DASH SIDE COVER (L)
12	15661	4	CAPSCREW
13	04539	4	WASHER
14	69463	1	DASH
15	03947	2	CAPSCREW
16	69483	10	SCREW
17	39076	3	BOOT PLATE
18	38549	3	BOOT
19	69485	2	SCREW
21	69475	1	THROTTLE CABLE ASSY
20	04539	4	WASHER
23	69464	1	DASH SIDE COVER (R)
24	69484	8	SCREW
25	370162	4	CAPSCREW
26	370154	2	CAPSCREW
26A	370154	2	CAPSCREW
27	04353	12	NUT
28	371067	14	WASHER
29	69491	16	CAPSCREW
30	69467	2	TENSIONER STUD
31	371513	2	NUT
32	69459	6	ROLLERS
33	69472	2	DRIVE MOTOR
34	69474	2	SPROCKET
35	24367	18	CAPSCREW
36	69473	2	RUBBER TRACK
37	69468	1	ROCK GUARD OUTER (R)
37A	69469	1	ROCK GUARD OUTER (L) (NOT SHOWN)
38	02116	8	CAPSCREW
39	69492	6	CAPSCREW
40	371514	8	NUT
42	69481	2	TENSIONER SPRING

ITEM	P/N	QTY	DESCRIPTION
43	69458	2	IDLER
44	68520	2	CAPSCREW
45	69466	2	IDLER YOKE
46	69470	2	ROCK GUARD INNER
47	69462	1	TAIL GATE
48	69482	2	LATCH
49	69461	1	MAIN BODY (MHP32242100)
49A	69756	1	MAIN BODY W/O BED (MHP32232100)
50	68336	2	TRACHORSE STICKER
51	47352	3	LIFT POINT STICKER
52	68335	1	THROTTLE STICKER
55	69476	1	THROTTLE KNOB
53	69486	1	2 SPEED SWITCH
54	69487	2	PLUG
56	69489	2	EXHAUST CLAMP
57	69480	1	EXHAUST TURN-DOWN
58	69479	1	MUFFLER
59	69478	1	EXHAUST PIPE
60	68334	1	DASH DECAL

HOSE & FITTING ILLUSTRATION

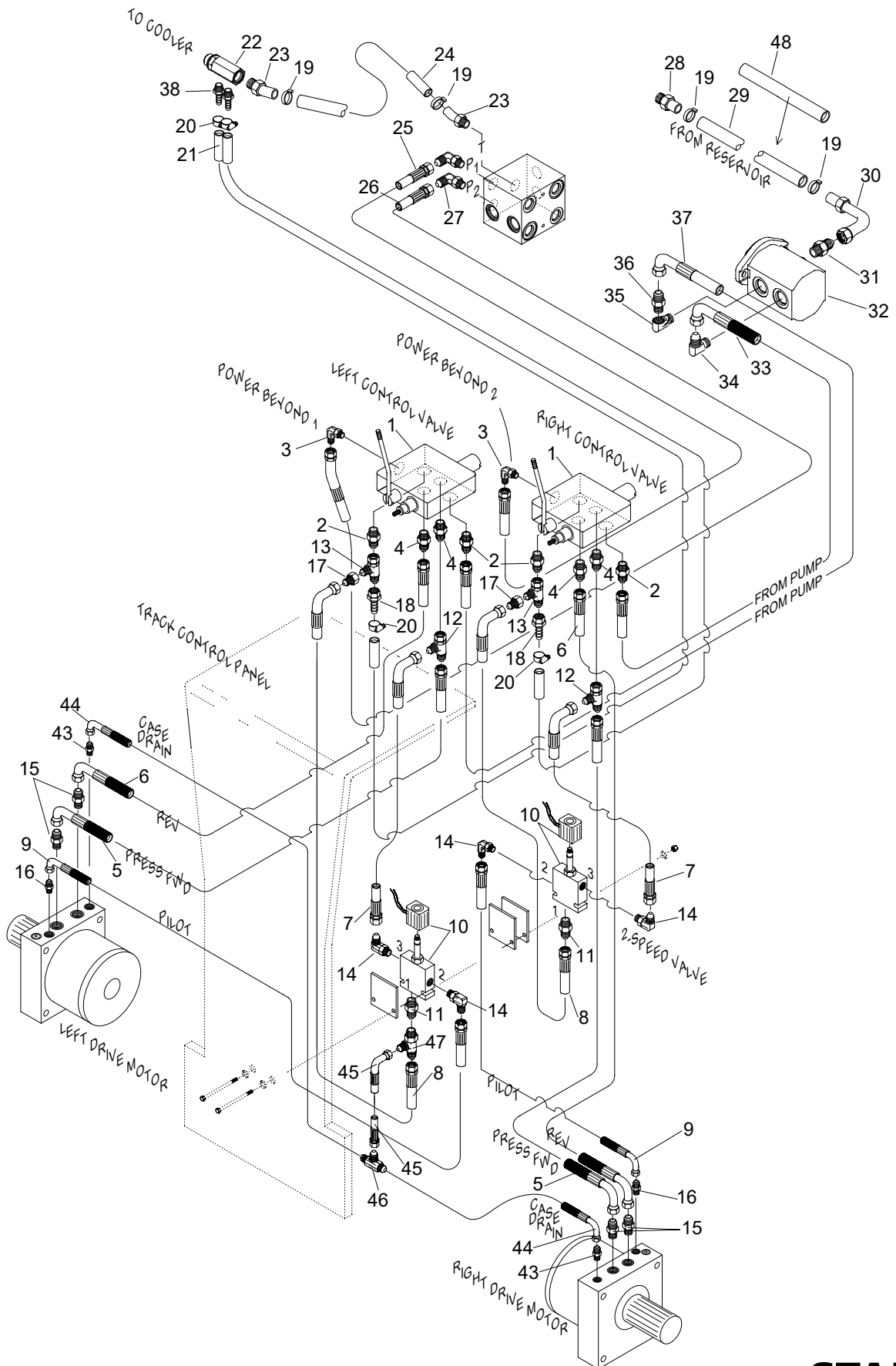

MHP3 PARTS LIST - HOSE & FITTING

ITEM	P/N	QTY	DESCRIPTION
1	69493	2	CONTROL VALVE
2	69495	4	STRAIGHT THREAD ADAPTOR
3	69496	2	STRAIGHT THREAD ELBOW
4	69497	4	STRAIGHT THREAD ADAPTOR
5	69503	2	HOSE ASSEMBLY
6	69504	2	HOSE ASSEMBLY
7	69505	2	HOSE ASSEMBLY
8	69506	2	HOSE ASSEMBLY
9	69507	2	HOSE ASSEMBLY
10	69494	2	SOLENOID VALVE
11	18556	2	STRAIGHT THREAD CONNECTOR
12	69500	2	SWIVEL NUT RUN TEE
13	350044	2	SWIVEL NUT RUN TEE
14	350059	4	STRAIGHT THREAD ELBOW
15	69501	4	STRAIGHT THREAD ADAPTOR BSPP-37° JIC
16	69502	2	STRAIGHT THREAD ADAPTOR BSPP-37° JIC
17	69498	2	REDUCER
18	69499	2	FEMALE JIC 37° SWIVEL
19	62199	4	HOSE CLAMP
20	08045	4	HOSE CLAMP
21	04875	2	HOSE, 54 IN. LONG
22	68083	1	EXTENSION ELBOW ASSY
23	40364	2	ELBOW 45-DEG -12 SAE 3/4 PUSH ON
24	59106	1	HOSE ASSY 18 IN. LONG
25	68547	1	HOSE ASSY
26	68546	1	HOSE ASSY
27	04860	2	STRAIGHT THREAD ELBOW
28	59105	1	ADAPTER 3/4 NPT x 3/4 HOSE
29	59089	1	HOSE 19 INCH LONG
30	58569	1	ELBOW
31	02773	1	STRAIGHT THREAD CONNECTOR
32	27695	1	HYD PUMP
33	68374	1	HOSE ASSY
34	68500	1	ELBOW
35	06960	1	ELBOW
36	350103	1	MALE CONNECTOR 10-8 FTX

ITEM	P/N	QTY	DESCRIPTION
37	68373	1	HOSE ASSY
38	04867	2	HOSE END BARB
39	69508	3	PLATE
40	03947	2	CAPSCREW
41	04539	4	WASHER
42	00719	2	NUT
43	76509	2	STRAIGHT THREAD ADAPTOR 4-4F 40MXS
44	76510	2	HOSE ASSEMBLY 5-3/4 LONG
45	76511	1	HOSE ASSEMBLY 9-3/4 LONG
46	76512	1	TEE 2603-04-04-04 FG
47	76513	1	TEE 6602-04-04-04 FG
48	68501	1	FIRE SLEEVE (PROTECTS ITEM 29 HOSE)

MHP3SCHEMATIC

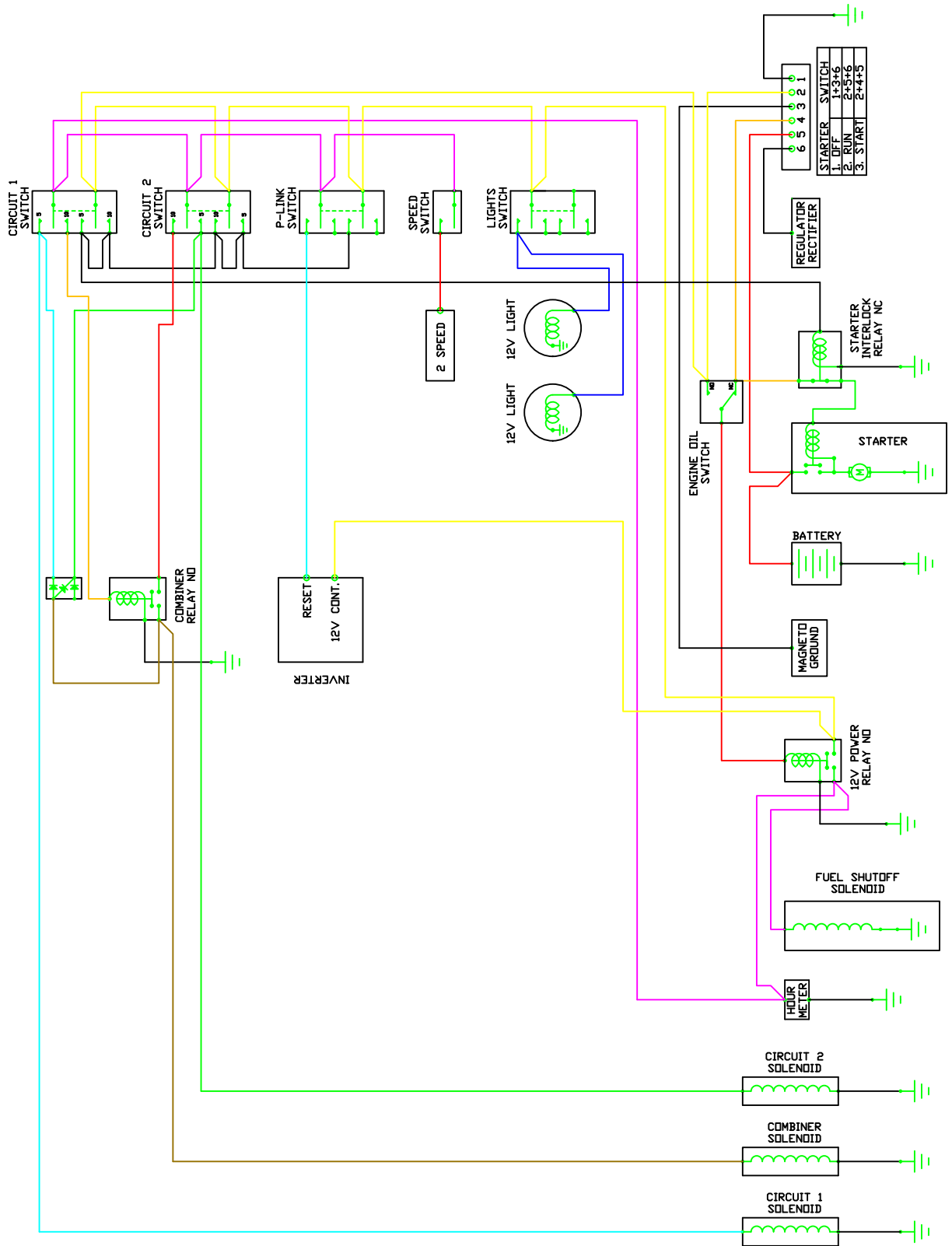

FRAME ILLUSTRATION

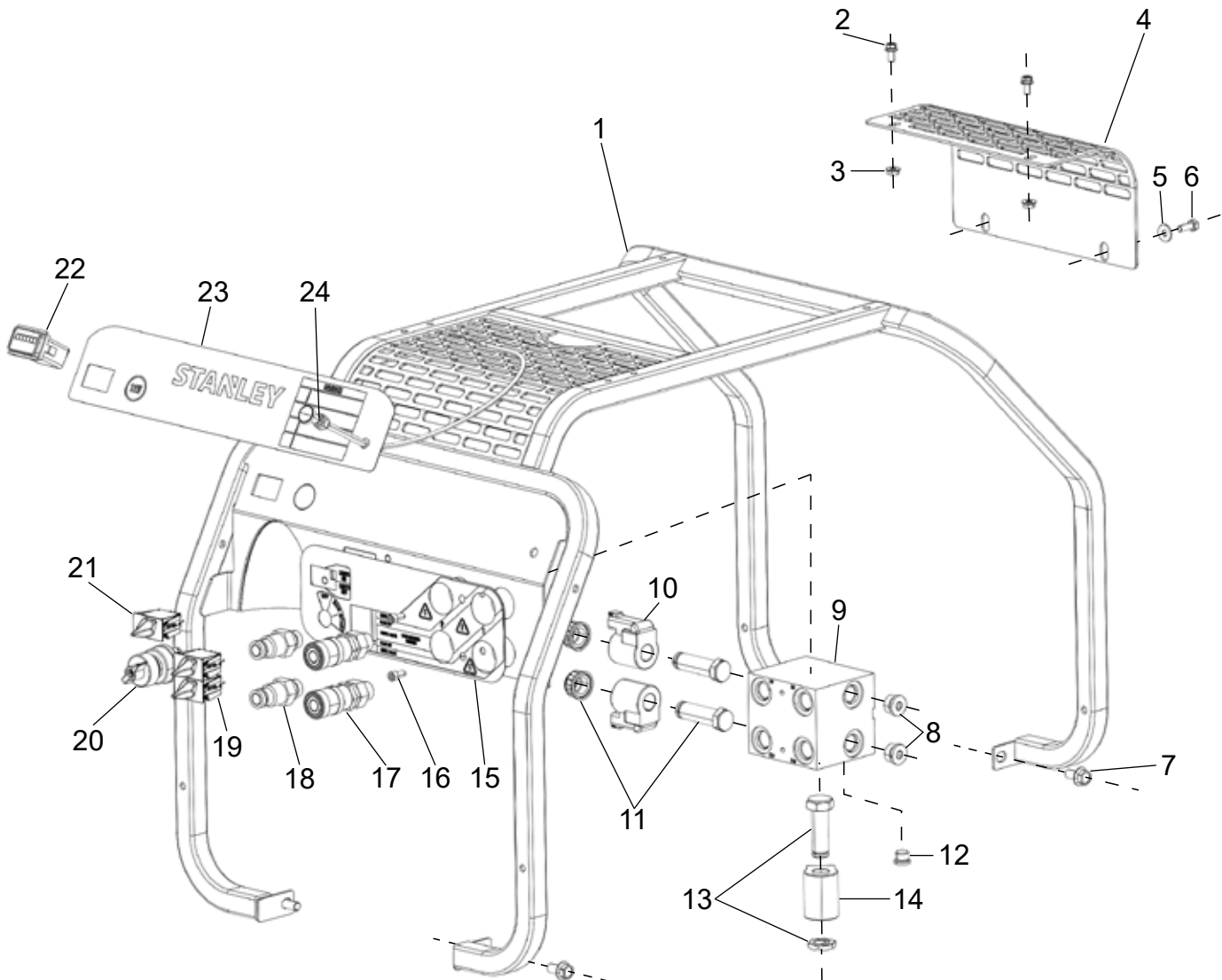

ITEM #	PART #	QTY	DESCRIPTION
1.	76712	1	Frame Weldment
2.	59074	2	Flange Bolt
3.	59095	2	Flange Nut
4.	59079	1	Cooler Guard
5.	60945	2	Washer
6.	15479	2	Capscrew
7.	23530	4	Flange Bolt
8.	350237	2	Hollow Hex Plug
9.	79334	1	Manifold
10.	60958	2	Solenoid Coil
11.	62319	2	Directional Valve with Cap
12.	08104	1	Hollow Hex Plug
13.	60960	1	Directional Valve with Cap
14.	62320	1	Solenoid Coil

ITEM #	PART #	QTY	DESCRIPTION
15.	80885	1	Dual Circuit Decal
16.	60962	2	Capscrew
17.	66785	2	Female Coupler, -8 ORB
	58856	2	Female Coupler (HP210HT)
18.	66784	2	Male Coupler, -8 ORB
	58857	2	Male Coupler (HP210HT)
19.	60956	2	Rotary Switch
20.	67899	1	3 Position Rotary Switch
21.	60955	1	Rotary Switch
22.	60946	1	Hour Meter
23.	74759	1	Dash Decal
24.	62298	1	Choke Cable Assembly

ENGINE ILLUSTRATION - BACK

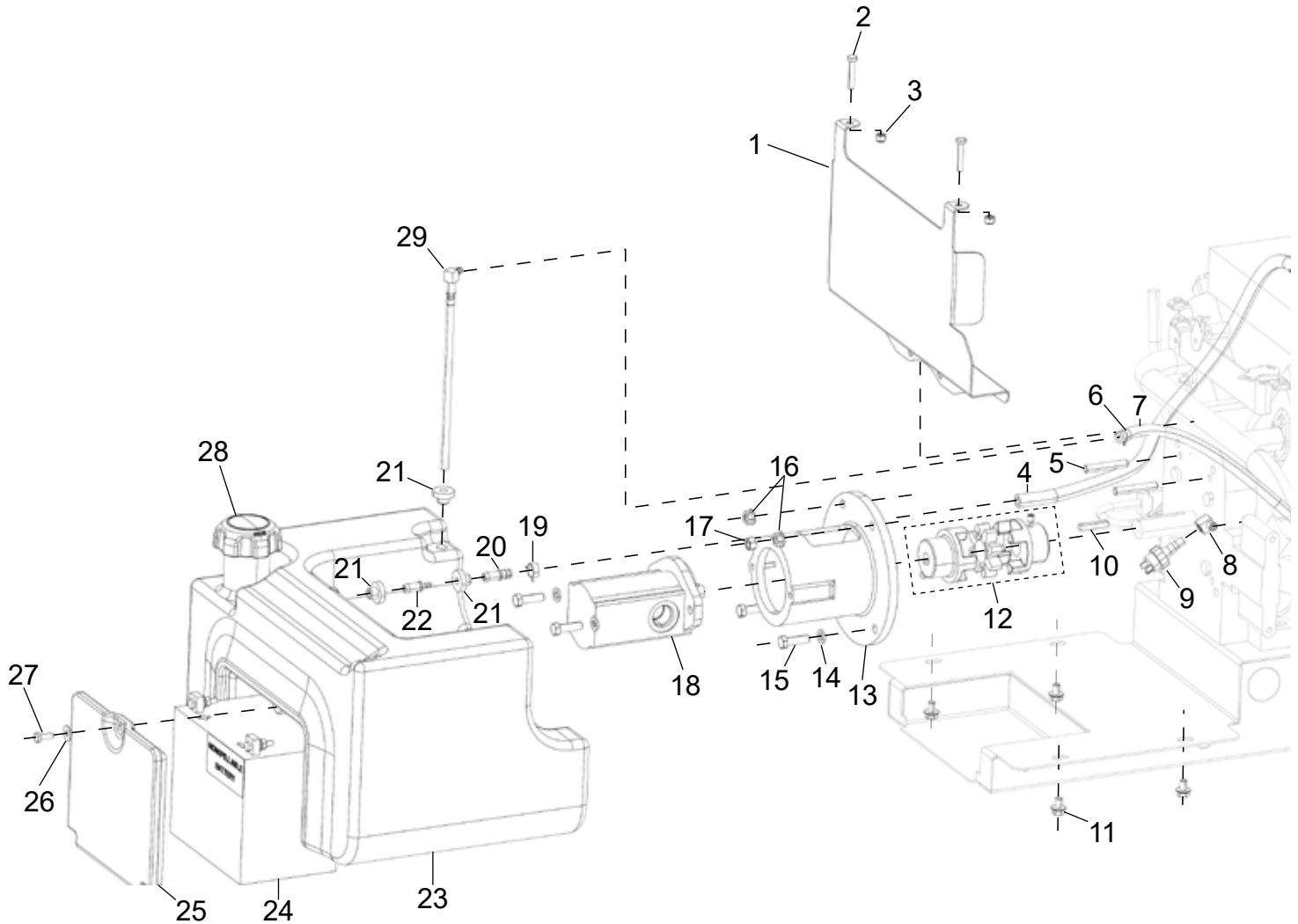

ITEM #	PART #	QTY	DESCRIPTION
1.	72238	1	Heat Shield
2.	21319	2	Capscrew
3.	00719	2	Nut
4.	72846	1	Fuel Vapor Hose
5.	62385	2	Stud
6.	72317	2	Hose Clamp
7.	72242	1	Fuel Hose
8.	69387	1	Elbow
9.	31765	1	Pressure Switch
10.	07819	1	Square Key
11.	40433	4	Flange Bolt
12.	56656	1	Coupling
13.	56655	1	Pump Mount
14.	01459	4	Lock Washer
15.	07860	4	Capscrew
16.	18893	2	Flange Nut

ITEM #	PART #	QTY	DESCRIPTION
17.	371503	1	Nut
18.	27695	1	Pump
19.	72848	2	Hose Clamp
20.	72847	1	Connector Fitting
21.	60920	3	Grommet
22.	72401	1	Connector
23.	73050	1	Fuel Tank
24.	04303	1	Battery
25.	60921	1	Battery Cover
26.	60945	1	Washer
27.	15476	1	Capscrew
28.	71794	1	Fuel Tank Cap
29.	60919	1	Fuel Elbow

ENGINE ILLUSTRATION - FRONT

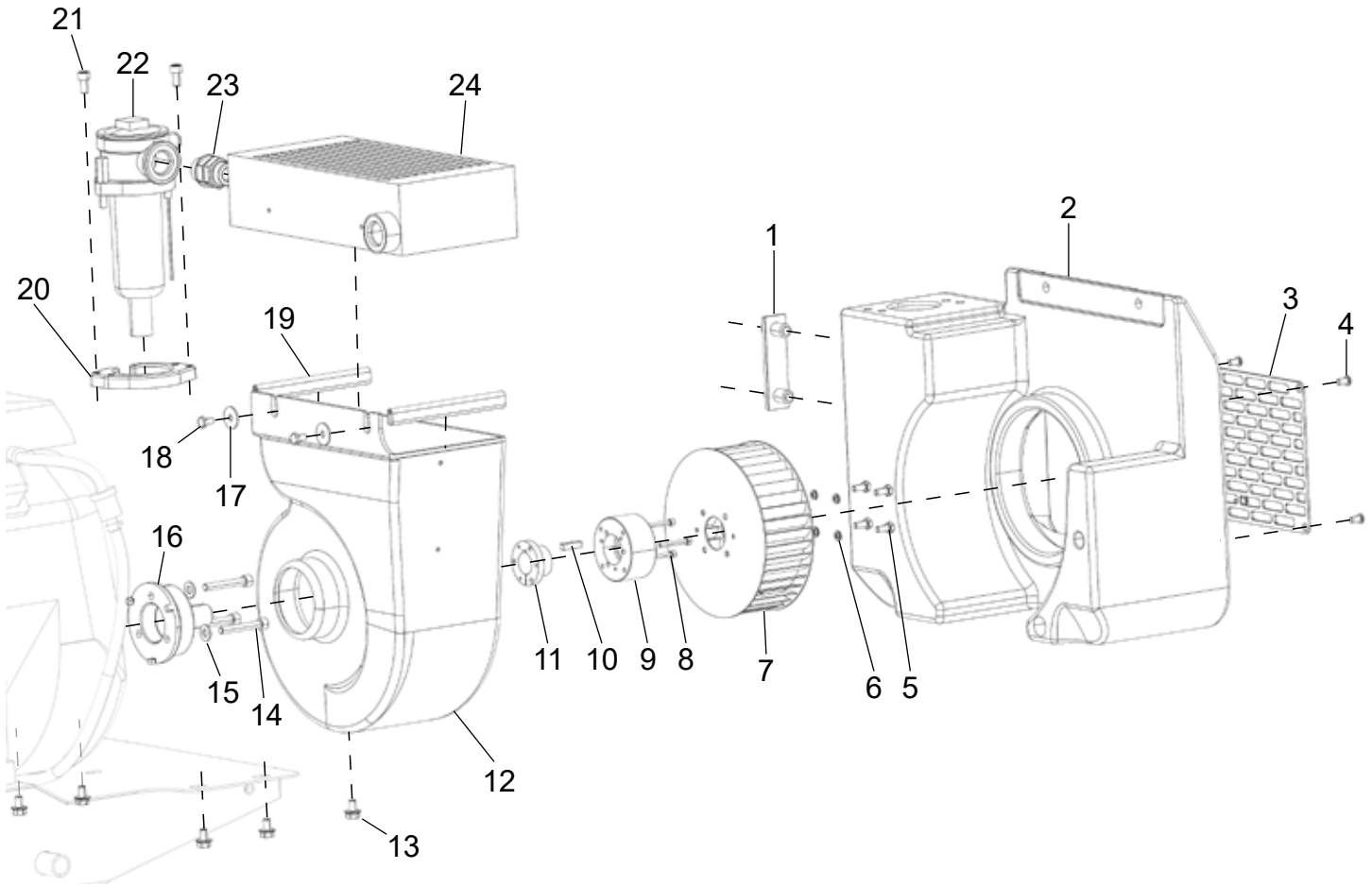

ITEM #	PART #	QTY	DESCRIPTION
1.	66788	1	Sight Gauge
2.	68499	1	Hydraulic Tank
3.	59080	1	Front Grille
4.	17821	4	Button Head Capscrew
5.	80986	4	Capscrew
6.	80984	4	Lock Washer
7.	65107	1	Blower Wheel
8.	00111	3	Capscrew
9.	59103	1	Blower Hub
10.	20990	1	Key
11.	59076	1	Bushing
12.	59083	1	Blower Housing
13.	40433	5	Flange Bolt
14.	60950	3	Capscrew
15.	60949	3	Washer
16.	-	1	Provided with Engine

ITEM #	PART #	QTY	DESCRIPTION
17.	26831	2	Washer
18.	01213	2	Capscrew
19.	62296	2	Weather Strip
20.	64937	1	Grip Plate
21.	43687	2	Capscrew
22.	40080	1	Filter Assembly
23.	51292	1	Standard Thread Union
24.	59091	1	Cooler

ENGINE ILLUSTRATION - BASE

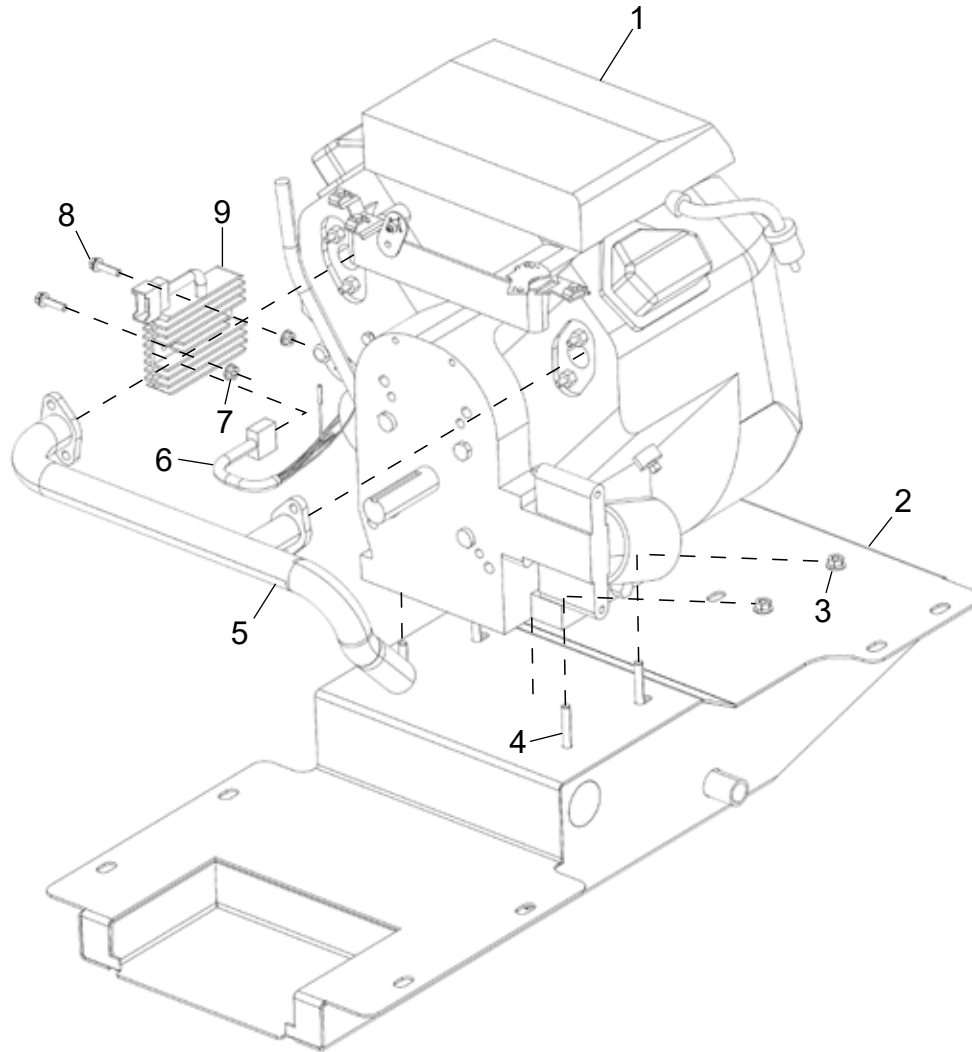

ITEM #	PART #	QTY	DESCRIPTION
1.	71976	1	Engine
2.	58897	1	Frame Base Weldment
3.	12787	4	Flange Nut
4.	58942	4	Flange Bolt
5.	-	1	Provided with Engine
6.	-	1	Provided with Engine
7.	59095	2	Flange Nut
8.	60953	2	Flange Bolt
9.	-	1	Provided with Engine

STANLEY®

STANLEY Infrastructure
6430 SE Lake Road
Portland, Oregon 97222 USA
(503) 659-5660 / Fax (503) 652-1780
www.stanleyinfrastructure.com