

Instruction Manual
for
Amron International, Inc.

**Models 8225-01, 8225-02 & 8225-04
Two Diver Air Control Systems**

S/N: _____



1380 Aspen Way, Vista California 92081-8349
United States of America
Phone: (760) 208-6500
Fax (760) 599-3857
email: sales@amronintl.com
web: www.amronintl.com

This manual and the information contained herein are provided for use as an operation and maintenance guide. No license or rights to manufacture, reproduce, or sell either the manual or articles described herein are given. Amron International, Inc. reserves the right to change specifications without notice.

Copyright© 2022 Amron International, Inc.

TABLE OF CONTENTS

1	SPECIFICATIONS	1
1.1	Air Control	1
1.2	Depth Monitoring (Pneumo).....	2
1.3	Communications	2
1.4	Enclosure	3
2	GENERAL INFORMATION	4
2.1	Options	4
2.2	Depth Monitoring.....	4
2.3	Low Pressure Alarm Module	4
2.4	Communications	5
3	SAFETY AND REGULATIONS	6
3.1	Diving Safety and Regulations	6
3.2	Personnel Requirements.....	7
3.3	Air Supply Requirements	7
3.4	Calibration, Service and Inspection	8
4	OPTIONS	8
4.1	Model 2401-28 Heavy Duty Headset	8
4.2	Model 2460-28 Standard Headset	8
4.3	Model 2405-28 Hand Held Microphone	8
4.4	Model 2822-28 Remote Walk-and-Talk (4-Wire Operation)	8
4.5	Model 2821-28 Walk-and-Push-to-Talk (2-Wire Operation)	8
4.6	Model HAS-300D 300 Bar DIN Adapter.....	9
4.7	Heating Element.....	9
5	CONTROLS & CONNECTIONS.....	10
5.1	Air Control	10
5.2	Depth Monitoring.....	11
5.3	Low Pressure Alarm.....	12
5.4	Communications	12
6	PRE-DIVE PROCEDURES.....	16
6.1	Pre-Dive Set-Up	16
6.2	Pre-Dive Check Out	16
6.3	Pre-Dive Pneumo Test.....	17
6.4	Pre-Dive Testing Communications.....	18
6.5	Connecting Diver Umbilical	18
6.6	Low Pressure Supply	18
7	OPERATING PROCEDURES	19
7.1	Low Pressure Breathing Air (Primary Supply)	19
7.2	High Pressure Breathing Air (Primary Supply).....	19
7.3	Pre-Operation Checklist	20
7.4	Pneumo Readings.....	21
7.5	Diver Communications	22
7.6	2-Wire Operation (Refer to Figure 3)	22

7.7	Diagram, 2-Wire Set-Up	24
7.8	Full Duplex (4-Wire) Operation (Refer to Figure 4).....	25
7.9	Diagram, Full Duplex (4-Wire).....	26
7.10	Flow Diagram	27
8	MAINTENANCE.....	28
8.1	Review of Scheduled Maintenance.....	28
8.2	Scheduled Maintenance.....	28
9	TROUBLESHOOTING AND REPAIR	30
9.1	General Information	30
9.2	Air Control	31
9.3	Depth Monitoring.....	33
9.4	Diver Communications	34
9.5	Problems and Their Possible Causes	36
10	REFERENCE MATERIAL	38
10.1	Diving Log, U.S Navy (Chart).....	38
10.2	Repetitive Dive Worksheet.....	39
10.3	No Decompression Limits	40
10.4	Gauge Pressure for Depth of Seawater & Freshwater	41
10.5	Equivalent Depths of Seawater & Freshwater	42
11	DRAWINGS AND SCHEMATICS.....	43
11.1	Parts Locator, 8225 Series Pneumo Panel (Front View)	44
11.2	Parts Locator, 8225 Series Pneumo Panel (Rear View).....	45
11.3	Parts Locator, 8225 Series Air Control Panel (Front View)	46
11.4	Parts Locator, 8225 Series Air Control Panel (Rear View)	47
11.5	Parts Locator, Model 26-1512-26-277 (Regulator)	48
12	PARTS LISTS.....	49
12.1	AMCOMMAND II Air Control System with Communicator, Model 8225-01	49
12.2	8225-200 Pneumo Panel Assembly.....	49
12.3	8225-400HP Air Control Panel Assembly	50
12.4	8225-500 Yoke/Hose Assembly.....	51
12.5	26-1512-26-277 Pressure Reducing Regulator	51
12.6	Front Panel Parts Identifier for 2825A-05 Communicator	52
12.7	Recommended Spare Parts.....	52
12.8	Regulator Repair Kit for 26-1512-26-277	53
12.9	Regulator Soft Goods Kit for 26-1512-26-277	53
13	REPAIR & CALIBRATION LOGS.....	54
13.1	Repair and Maintenance Log for Model 8225 Series	54
13.2	Pneumo Gauge Calibration Log, Model 520-0013-01	55
14	LIMITED WARRANTY AND SERVICE POLICY.....	56

1 SPECIFICATIONS

1.1 AIR CONTROL

High Pressure Input

Input Pressure Range

500-3000 PSI..... with use of standard CGA850 Yoke Connections

500-4500 PSIwith use of optional 300 Bar DIN Adapters

Inlet Valve (Source Select)..... 2

Gauge - 0-6000 PSI.....Accuracy +/- 1.5%

Check Valve, prevents reverse inlet flow 2

Input Filter, In Line Pre Regulator 50 Micron

CGA850 Yoke connections with 6 ft. high-pressure hose whips (standard) 2

***** Available with optional 300 Bar DIN Adapters, Amron Part No. HAS-300D *****

High Pressure Regulator, Tescom

Outlet Pressure Range 0-265 PSI

High Flow.....Cv = 0.24

Max Pressure 4500 PSI

Low Pressure Input, with Check Valve

Max Pressure 285 PSI

Inlet Connection (#6 JIC)..... 1

Diver Outlet Connection, (O2 Fitting) 2

Diver Outlet Valve..... 2

Air Pressure Gauge, 0-600 PSIAccuracy +/- 1.5%

Over Pressure Relief Valve Set Pressure 285 PSI

Universal Storage lock – CGA850 Yoke & 300 Bar DIN

HP hoses and CGA850 yokes or optional 300 BAR DIN connections are secured to universal storage blocks mounted on air control panel located inside of unit.

Panel

Material Stainless Steel

Powder Coating Black Textured Semi-Gloss Polyester

Silkscreen GraphicsRed, White & Blue

1.2 DEPTH MONITORING (PNEUMO)

Pneumo Gauge

Mirrored Scale, 6 Inch 2
 Range Dual Scale 0-250 FSW/0-76 MSW
 Divisions 1 Foot
 Accuracy 0.25% of Full Scale

Pneumo Valve

Regulating Valve, KEL-F Seat 2

Outlet Connection

O2 Fitting Chrome Plated Brass 2

Low Pressure Alarm

Audio Range, 22.5-125 PSI Factory set at 100 PSI

Panel Material

Material Aluminum
 Powder Coating Black Textured Semi-Gloss Polyester
 Silkscreen Graphics Yellow

1.3 COMMUNICATIONS

AMCOM II, Model 2825A-05 Two Diver Communicator

SPECIFICATIONS

Input Impedance (Each Input) 250 Ohms
 Frequency Response 300 - 10000 Hz
 Common Mode Rejection 40 dB Minimum
 Current Drain Maximum Full Volume 3 Amps
 Minimum Quiescent 0.190 Amps
 Output Impedance 4 Ohm
 Power Supply Voltage 12 VDC Nominal (9 VDC Min - 16 VDC Max)
 AC Power Operating Range 90-264 VAC, 50-60 Hz
 Sensitivity (Input) 0.5 mV
 Output Power (RMS @ 4 Ohm Load, 12 VDC) 10 Watts Audio
 Battery Life 45 Hours
 Panel Black Powder Coat over Stainless Steel with White Silkscreen Graphics

1.4 ENCLOSURE

Case Material

Pressure molded fiberglass, with aluminum and or stainless steel hardware. Includes carrying handle, latches, and stay hinge to lock unit in open position (upper section is locked upright in respect to lower section).

Case

Lid closed..... 20" W x 14" D x 12" H
 Lid Open 20" W x 14" D x 21" H
 Weight:Approximately 70 lbs.
 Color: International yellow



Available Models & Options:

- 8225-01** Two Diver Air Control System & 2825A-05 Communicator (Shown Above)
- 8225-02** Two Diver Air Control System with Heating Element & 2825A-05 Communicator
- 8225-04** Two Diver Air Control System less Communicator

2 GENERAL INFORMATION

The AMRON AMCOMMAND II 8225 Series is a portable self-contained two-diver high and low pressure air control, communication and depth monitoring (pneumo) system, for surface supplied diving operations. The system is designed to provide a central control point for the supply of breathing air to the divers, monitor the diver's depth, and provide two-way communications between the divers and the surface. The system is housed in a durable pressure fused fiberglass case, which provides a convenient, compact, rugged, professional system.

2.1 OPTIONS

The Air Control Section consists of two high-pressure inputs, a single low-pressure input, and two diver umbilical connections.

2.1.1 Standard 3000 PSI MAX Input

All Models come standard with 2 each CGA850 yokes attached to 6-foot long HP hoses. The CGA850 yoke limits the maximum input pressure to 3000 PSI

2.1.2 Optional 4500 PSI MAX Input

Installing the 300 Bar DIN Adapters, Amron Part No. HAS-300D, will increase the maximum input pressure limit to 4500 PSI. Simply remove CGA850 yoke nut and yoke from bleeder body, screw on 300 Bar DIN adapters, and tighten with a wrench. Each input has a shut-off valve and 0-6000 psi gauge.

Check valves provide protection against back flow of air from a full bottle to an empty, when switching HP bottles. High-pressure air is reduced to desired low pressure via a Tescom adjustable regulator. The input to the regulator is protected against contamination by a 50-micron filter. Regulator output pressure is adjustable over the range of 0 to 285 psi; a 2 1/2" 0-600 PSI gauge monitors the output pressure. The unit has an over pressurization relief valve, factory set to 285 psi.

The low-pressure input is #6 JIC (3/8), and has a check valve to permit simple switch over from low-pressure air to high-pressure air.

2.2 DEPTH MONITORING

The diver's pneumo connection is an O2 type fitting; pneumo valves are regulating type. Pneumo gauges are 6" high, precision 0.25% of full-scale accuracy, dual scale 0-250 FSW/0-76 MSW with one foot increments. Gauge protectors are provided for each pneumo gauge.

2.3 LOW PRESSURE ALARM MODULE

Low Pressure Alarm Module supplies a loud audio signal to alert the operator when a diver's air pressure falls below a preset limit of 100 PSIG.

2.4 COMMUNICATIONS

The diver communication system is based on the field proven AMRON 2825A Series. The unit is powered from a built-in internal charger with rechargeable gel-cell battery. Operating time from fully charged battery is approximately 45 hours. Unit can also be operated from an external 12 VDC source, via charger jacks on the front panel. The communicator has a unique battery condition indicator. Steady GREEN light indicates battery voltage level is good. Blinking GREEN light indicates battery voltage is approaching a low level (approx. 3 hours of operation remain). Steady RED light indicates battery voltage is below the level necessary to guarantee proper operation.

WARNING: When Battery Condition indicator is steady RED light, communication will stop. The battery condition indicator also functions in the same manner when operating from an external power source.

Possibly the most useful feature of the AMCOMMAND communicator is the ability to operate the unit remotely. This feature allows the use of a hand-held, push-to-talk microphone (included), or a walk and talk type module (optional). This allows the tender (operator) to move about and still maintain contact with the divers.

The use of the noise canceling push-to-talk microphone automatically disconnects the speaker when talking to the divers, cutting out the majority of the background noise which greatly improves the intelligibility of communications.

The communicator provides 10 watts voice power. This power level provides the volume necessary to communicate clearly even under difficult conditions. Standard controls include: power on/off, tender volume, diver volume, speaker on/off, 5-way binding post diver input, push-to-talk switch, headset/microphone jack, and remote push-to-talk jacks.

3 SAFETY AND REGULATIONS

Safe diving does not happen by accident. There are few occupations in the world which require such a broad range of knowledge and training as diving. There are many diverse factors which can affect diving safety, i.e. planning, weather, equipment, location, water conditions, as well as the type of work being done. The single most important factor in eliminating accidents is planning and attention to detail. Diving knowledge, training and experience are fundamental elements needed to execute a safe dive.

The following reference materials are recommended as sources of information for running a safe diving operation:

1. U.S. Department of Labor, OSHA Regulations 1910.401 Sub-part T–Commercial Diving Operations.
2. U.S. Navy Diving Manual.
3. Divers Handbook of Underwater Calculations.

3.1 DIVING SAFETY AND REGULATIONS

3.1.1 Diving Regulations

Several codes and regulations cover diving operations and procedures. In the United States most commercial diving operations are covered by the OSHA (Occupational Safety and Health Administration) regulations, or individual state regulations, which are adopted from the federal regulations, and made a part of the civil code.

While government agencies are exempt from OSHA regulations, they generally fall under other regulations, which are similar or stricter than OSHA. If they are completely exempt, they must still abide by the procedures for operating a safe dive.

While no agency (within the U.S., for commercial diving operations) tests or approves equipment for use, they do establish minimum standards which should be followed. The suitability of a given piece of equipment for a particular task is left to the supervisor of the dive. The following information is extracted from the OSHA regulations for commercial diving operations.

NOTE: The information is not presented as a direct or complete quotation, but rather as our interpretation of the regulations. Each diving supervisor should obtain a copy of these regulations for their own use.

Copies of the complete section of Commercial Diving Operations are available from Amron International for a nominal charge.

WARNING: DO NOT USE THE AMCOMMAND II FOR THE FOLLOWING:

- Mixed gas diving operations with an oxygen level greater than 25%.
- Oxygen or oxygen enriched breathing mixtures above 25%.

The AMCOMMAND II is not designed or intended for these applications.

3.2 PERSONNEL REQUIREMENTS

1. Each dive team member shall have the experience or training necessary to perform assigned tasks in a safe and healthful manner. The person operating the AMCOMMAND II must be trained in the proper operating procedures and emergency operating procedures.
2. It is the responsibility of the designated person in charge of the diving operation to be on site at all times. He is responsible for all aspects of the diving operation affecting the health and safety of dive team members.
3. The dive shall be terminated when:
 - A diver requests termination.
 - A diver fails to respond to instructions.
 - Diver communications are lost and cannot be re-established quickly.
 - A diver begins to use diver carried back-up breathing air or location reserve breathing air.
 - Operational conditions deteriorate to a point where safe diving cannot be guaranteed.

3.3 AIR SUPPLY REQUIREMENTS

WARNING

Regardless of the type of air supply being used for surface supplied diving; the diver must always have a back-up supply of air. Generally this is in the form of a bailout bottle. The back-up air supply must be adequate to return the diver to the surface; if the dive requires in-water decompression, this must be accounted for also.

1. The diver's air supply may originate from a low-pressure air compressor, high-pressure air cylinders, or a combination of both. Regardless of the source, the air must meet certain established standards of purity and must be supplied in an adequate volume for breathing.
2. The air supply requirements depend upon the specific factors of each dive such as depth, duration, level of exertion, and type of diving system (helmet/hat) being used. It is the dive supervisor's responsibility to ensure that an adequate supply of air is available and on site for the planned dive. This includes sufficient back up air to safely return the diver to the surface in the event the primary supply of air is lost.
3. Low-pressure compressors used for breathing air should be specifically designed for diving. Compressors used to supply air to the divers shall be equipped with a volume tank which has a check valve on the inlet side, a pressure gauge, relief valve, drain valve, and a proper filtration system. The output of the air compressor system shall be tested for air purity every 6 months by means of an air sample.

4. Air compressor intakes shall be located away from and up wind of areas containing exhaust or other contaminants.

NOTE: OSHA regulations require a decompression chamber capable of recompressing the diver at the surface to a minimum of 165 FSW (6 ATA) shall be available at the dive location for a surface supplied air diving to depths deeper than 100 FSW.

3.4 CALIBRATION, SERVICE AND INSPECTION

1. Each depth gauge shall be dead weight tested or calibrated against a master reference gauge every 6 months or if there is a discrepancy greater than two percent (2%) between any two equivalent gauges.
2. Each equipment modification, repair, test, calibration, or maintenance service shall be recorded by means of a tagging or logging system, and include the date and nature of work performed, and the name of the person performing the work. For your convenience a repair service log is provided at the end of this manual.
3. Equipment Inspection; Prior to each dive, the equipment shall be inspected and checked to ensure that it is in proper working order.

4 OPTIONS

4.1 MODEL 2401-28 HEAVY DUTY HEADSET

The Model 2401-28 is a high quality heavy-duty Telex headset with boom microphone. It has superior sound quality and comes equipped with color-coded dual banana plugs, 6-foot (1.8-meter) cord, and mates directly to communicator.

4.2 MODEL 2460-28 STANDARD HEADSET

The Model 2460-28 is a light and comfortable headset designed for extended wear at an economical price. It comes equipped with color-coded, dual banana plugs that mate directly to AMCOM diver communicators. The spiral cord can extend up to 8 feet (2.4 meters).

4.3 MODEL 2405-28 HAND HELD MICROPHONE

The Model 2405-28 is a hand-held, noise-canceling, push-to-talk microphone that provides excellent sound quality to the diver. It comes equipped with a spiral cord that can extend up to 6 feet (1.8 meters).

4.4 MODEL 2822-28 REMOTE WALK-AND-TALK (4-WIRE OPERATION)

AMRON headset extension (remote walk and talk), with belt module, jacks for headset, 25 feet 1/4" O.D. cable (Use with Model 2460 28 headset with boom microphone).

4.5 MODEL 2821-28 WALK-AND-PUSH-TO-TALK (2-WIRE OPERATION)

AMRON headset extension (remote walk and talk), with push-to-talk belt module, jacks for headset, 25 feet 1/4" O.D. cable (Use with Model 2460-28 headset with boom microphone).

4.6 MODEL HAS-300D 300 BAR DIN ADAPTER

Converts a standard Amron CGA850 Yoke (3000 PSI) to 300 Bar DIN (4500 PSI) use.

4.7 HEATING ELEMENT

Optional heating cable is 18 ft. long and is wrapped around the high pressure input and regulator section located on the backside of manifold panel; the standard plug connection 120 VAC heater is located on the front panel for ease of use; lower case is insulated with closed cell foam to help protect against severe weather conditions as an added safety feature, a GFCI in-line cord set is supplied.

5 CONTROLS & CONNECTIONS

Before using the AMCOMMAND II Model 8225 Series, familiarize yourself with its operating controls and connections. For simplicity, the controls and connections are divided into three categories. The categories are Air Control, Pneumo, and Communications.

5.1 AIR CONTROL

The Air Control section consists of a high-pressure section and a low-pressure section. The system is designed to supply breathing air to a diver through an umbilical. This is known as surface supplied diving. The air the divers are breathing is supplied from the surface.

5.1.1 High-Pressure

Accepts breathing air from SCUBA bottles or any other suitable source, i.e. high-pressure flasks. The pressure is reduced to a level suitable to the needs of the diver via a pressure-reducing regulator. The pressure required by the diver is determined by the type of helmet/hat being used and the depth at which the diver is working. The general rule of thumb is bottom pressure plus over-bottom pressure required for a given type of diving helmet/hat. Consult your diving helmet/hat manufacture/manual for the requirement of the helmet/hat you are using.

The High-Pressure section has two inputs, complete with high-pressure hose whips, CGA850 SCUBA bottles yokes, and pressure reducing regulator.

5.1.2 Standard 3000 PSI MAX Input

All models come standard with 2 each Amron CGA850 yokes attached to 6-foot long HP hoses. The CGA850 yoke limits the maximum input pressure to 3000 PSI.

5.1.3 Optional 4500 PSI MAX Input

Installing the 300 Bar DIN Adapters, Amron Part No. HAS-300D, will increase the 8225 Series to a maximum input pressure limit to 4500 PSI. Simply remove Amron CGA850 yoke nut and yoke from bleeder body, screw on 300 Bar DIN Adapter and tighten with a wrench

1. Source select inlet valve handles are color coded Red and Blue to correspond to the hose whips which are also color-coded Red and Blue. This helps the operator identify which valve controls which tank. For maximum airflow, turn handle counter clockwise four (4) full turns. To shut-off valve, turn handle clockwise until it stops.
2. Inlet gauge reads actual input pressure of air source. Gauge pressure range is 0-6000 psi; accuracy is 1-1/2% of full scale.
3. Check valves (HP section) prevent input air from one source flowing into a second lower pressure source when both source valves are open. This simplifies the switch over from one SCUBA bottle to another. NOTE: If both source valves are left open with full bottles the bottles will be drawn from equally.

4. The Amron CGA850 input yokes are standard with bleed valves and color-coded 6-ft. high-pressure hose whips. The CGA850 input yokes are limited to maximum pressures of 3000 PSI and fit standard SCUBA bottle valves.
5. A pre-regulator filter prevents debris from contaminating the regulator. Filter element is 50 micron.
6. High pressure TESCO regulator(s) reduce pressure of incoming air from high-pressure bottles to a level required by diver's helmet / hat. To increase the diver's air pressure, turn knob clockwise to desired setting. To decrease the diver's air pressure, turn knob counter clockwise. NOTE: Regulator is a non-venting type; in order to reduce the set pressure, air must be flowing through the regulator.

5.1.4 Low-Pressure

The Low-Pressure section consists of an LP input, low pressure output of regulator, LP gauge, and diver connection. A small portion of the LP air is also used when diver depth measurements are made.

LP input accepts breathing air from a low-pressure source i.e., a low pressure diving air compressor. Note: The low-pressure section does not regulate the air pressure to the diver. The compressor must be set to provide the proper pressure to the diver.

Breathing air from the low-pressure side of the regulator or the low-pressure input is routed to the diver's breathing air connections. A portion of the low-pressure air is used by the pneumo section for diver depth measurements.

1. Low-pressure input, #6 JIC type fitting. (O₂ type fitting available).
2. Low-pressure check valve prevents the back flow of air from the HP regulator output into the LP air source. This also permits simple switch over from LP to HP air.
3. 1/4 Turn ball valve controls flow of air to diver. Ball valve permits unrestricted flow.
4. Divers air supply gauge reads air pressure to divers, 0-600 PSI.
5. Divers air supply outlet connection, O₂ (oxygen) type fitting. (37° JIC optional).
6. Pressure relief valve, factory set for 285 PSI, vents excess pressure to atmosphere. Vent is located between diver output connections.

5.2 DEPTH MONITORING

The Pneumo Fathometer section is used to measure the diver's depth. Pneumo readings are made by pressurizing the diver's pneumo hose. Air is forced through the pneumo hose until all water is displaced. The air is then shut off and the pressure is read on a high accuracy gauge calibrated in FSW (feet of seawater). See Section 8, Page 33, Par. 12 for details. The system components are:

1. Diver pneumo valve (yellow handle) controls the air supply to the pneumo Fathometer system, one for each diver.

2. Pneumo gauge, dual scale 0-250 FSW/0-76 MSW, mirrored scale, 6 inch, high precision, 0.25% of full scale accuracy, one for each diver.
3. Diver pneumo outlet connections are O2 (oxygen) type fittings. (37° JIC fitting optional).

5.3 LOW PRESSURE ALARM

Monitors the divers air pressure. Alarm is factory set to 100 PSI, when pressure drops below the set point the audio alarm is turned on.

1. ON/OFF switch turns alarm on or off as desired.
2. Audio transducer emits audio tone at 2900 Hz at a level of 90 dB.
3. Pressure switch, (internal) adjustable 25 to 300 PSI set point. Factory set to 100 PSI.

5.4 COMMUNICATIONS

Two-way communications with diver's high power, folded acoustic horn, provides ample volume for noisy environments. Speaker is mounted in the optimum plane to direct sound to the operator.

5.4.1 Tender Controls

POWER SWITCH – This switch controls power to the unit.

PUSH-TO-TALK ALL DIVERS BUTTON – This button allows the tender to talk to all the divers when operating in the 2-Wire mode. It is not necessary to use this control in the Full Duplex (4-Wire) mode. When using Full Duplex mode, this control allows the tender to interrupt the divers by forcing them into listen only mode.

EARPHONE VOLUME – This control sets the volume for the tender's earphone and/or PANEL SPEAKER. Rotate this knob clockwise to increase the volume from all the divers.

MICROPHONE VOLUME – This control sets the level for the tender's microphone. Rotate this knob clockwise to increase the tender's volume to all the divers.

HAND HELD MICROPHONE - Convenient method to talk to divers; automatically activates the push-to-talk function and disconnects the talk back speaker reducing background noise. This feature significantly improves intelligibility.

5.4.2 Tender Connections

TAPE RECORDER – This is a single RCA Phono jack (color-coded black) that provides a transformer isolated of both the diver and tender communications. It is designed to drive the standard line-level inputs of audio or video recorders with input impedances as low as 600 Ohms.

TENDER HEADSET JACK – This is the dual banana jack (color-coded black) that functions as both an output (earphone) and input (microphone) for the tender as controlled by the PUSH-TO-TALK BUTTON and PUSH-TO-TALK JACK. Using this connection, the tender can be wired in either 2-Wire or Full Duplex (4-Wire) mode regardless of the mode used for the diver.

To connect the tender in the Full Duplex (4-Wire) mode, connect the earphone (black) banana plug of the headset to this jack and the microphone (red) to the TENDER MICROPHONE jack (red) as shown in the wiring diagram in section 4.9. In this mode, the tender does not have to use the PUSH-TO-TALK BUTTON to communicate with a diver who is also connected in the Full Duplex (4-Wire) mode. This configuration can be used even if the diver is connected in 2-Wire mode. In that situation, the tender is required to use the PUSH-TO-TALK BUTTON or PUSH-TO-TALK JACK.

The headset microphone is always active, which means that there can be acoustic feedback between the PANEL SPEAKER and the microphone if the tender is near the communicator. To prevent this, the PANEL SPEAKER can be turned off using the SPEAKER SWITCH. Another option is to move the tender away from the communicator by using the Amron Model 2822-28 Walk-and-Talk Module accessory. This allows the tender to communicate while other members of the surface crew listen using the PANEL SPEAKER. This module comes with 25 feet (7.6 meters) of cable (custom cable lengths are available).

The tender can also be connected in 2-Wire mode by stacking both the earphone (black) and microphone (red) banana plugs into this jack as shown in the wiring diagram in section 4.8. The diver does not have to be connected in 2-Wire mode if the tender is in 2-Wire mode. In order to talk to the diver, the tender must use either the PUSH-TO-TALK BUTTON or PUSH-TO-TALK JACK. Since the headset microphone is not active until one of the push-to-talk methods is used, there is no chance for acoustic feedback to occur and surface conversation or noise is not transmitted to diver and the PANEL SPEAKER can be left on. This may, for some situations, make for a better overall diving experience. If the tender requires more mobility at the dive site, the Amron Model 2821-28 Remote Push-to-Talk Module can be used to extend the headset cable. It includes a push-to-talk button on a clip-on belt module and comes standard with 25 feet (7.6 meters) of cable (custom cable lengths are available).

The tender may also use the optional Amron Model 2405-28 Push-to-Talk Microphone. This microphone comes with two color-coded banana plugs. The black plug goes into the TENDER HEADSET jack and the yellow plug goes in the PUSH-TO-TALK JACK as shown in the wiring diagram in section 4.10. To communicate with the diver, the tender presses the button on the side of the microphone. There is no chance of acoustic feedback since the PANEL SPEAKER is cut off when the tender uses the microphone. When using the Push-to-Talk Microphone, the SPEAKER SWITCH must be turned on in order to hear the diver.

TENDER MICROPHONE JACK – This is a dual banana jack (color-coded red) that functions as the microphone input from the tender's headset. It is only used if the tender is in Full Duplex (4-Wire) mode. The TENDER MICROPHONE VOLUME control adjusts the sensitivity of the input.

PUSH-TO-TALK JACK – This is a dual banana jack (color-coded yellow) that allows for remote keying of the push-to-talk function of the communicator. It is used by the Push-To-Talk Microphone (Amron Model 2405-28) and the Remote Walk-And-Talk Module (Amron Model 2822-28).

The difference between using the PUSH-TO-TALK JACK and PUSH-TO-TALK SWITCH is that the switch allows the tender to communicate using the PANEL

MICROPHONE. If both are used at the same time, the PANEL MICROPHONE is active. This allows another crew member to talk to the diver using the PANEL MICROPHONE even if the tender is away from the communicator using the Remote Push-to-Talk Module in 2-Wire mode.

5.4.3 Diver Controls (separate controls for each diver)

DIVER EARPHONE VOLUME has separate earphone volume controls for each diver. This allows the tender to set the best individual volume for each diver.

DIVER MICROPHONE has separate microphone volume controls for each diver. This sets amplification level of each diver's microphone signal controlling that diver's volume to both the tender and the other diver.

PUSH-TO-TALK-DIVER – There is a separate PUSH-TO-TALK button for each diver. Normally used in 2-Wire mode, this control allows the tender to talk to only one of the divers. The diver selected will hear both the tender and the other diver allowing crosstalk between the divers controlled by the tender. It can be used in Full Duplex (4-Wire) to cut off the microphone of an individual diver.

5.4.4 Diver Connections

DIVER MICROPHONE – This is a dual 5-way binding post jack (color-coded red) that functions as both an output (earphone) and input (microphone) for the diver as controlled by the PUSH-TO-TALK BUTTON and PUSH-TO-TALK JACK. Using this connection, the diver can be wired in either 2-Wire or Full Duplex (4-Wire) mode regardless of the mode used for the diver.

To connect the diver in 2-Wire mode, connect both the diver microphone and earphone to this jack. If the diver umbilical uses banana plugs, simply stack both plugs into this jack as shown in the wiring diagram in section 4.8. In this mode, the diver microphone will be active and heard on tender headset and/or PANEL SPEAKER unless the PUSH-TO-TALK BUTTON or PUSH-TO-TALK JACK is used. When a pre-amp microphone is used in the 2-Wire mode setup, it is required to have special speakers supplied only by Amron. Contact Amron for more information.

To connect the diver in Full Duplex (4-Wire) mode, connect the diver microphone to this jack and the diver earphone the DIVER EARPHONE jack as shown in the wiring diagram in section 4.9. The diver can use this mode even if the tender is wired in 2-Wire mode.

DIVER EARPHONE – This is a dual 5-way binding post jack (color-coded black) that functions as the output for the diver's earphone. It is only used when the diver is in Full Duplex (4-Wire) mode.

5.4.5 Power Connections

EXTERNAL BATTERY JACK – The communicator can be powered using an external battery or power supply via the two color coded TIP jacks. The red TIP jack is the positive power input and the black is the negative power input. The input voltage must be between 9 and 15 VDC and must be able to supply a peak current of 3 Amps for proper operation. The following warnings need to be heeded when using the EXTERNAL BATTERY JACK. A minimum wire size of 18 AWG and maximum wire run of 3 feet (1 meter) is recommended.

If you use an external power supply, the maximum voltage cannot exceed 15 Volts.

BATTERY CONDITION INDICATOR – A steady GREEN light indicates battery charge level is good. Blinking GREEN light indicates battery charge level is at a low level with less than 3 hours of running time available. Steady RED light indicates battery charge level is below the level necessary to guarantee proper operation.

6 PRE-DIVE PROCEDURES

6.1 PRE-DIVE SET-UP

1. Place AMCOMMAND II on flat surface that can support the unit. Select a working area which is secure, stable, convenient, and suitable for use during the period of the dive.
2. Open unit and remove both yokes and color coded high pressure hose whips from the storage position. Conduct a visual inspection of unit to insure no damage has occurred during transportation to the job site, or since the last time the unit was used.
3. Attach each yoke to a scuba cylinder by screwing down until finger tight. Note: be sure the bleeder valve on each yoke is in the closed position. (Note: do not turn the cylinder's air on at this time).
4. If available, a low pressure compressor should be used as the primary air supply and scuba cylinders used as a back-up air source.

Note: Low pressure compressors used for breathing air should be specifically designed for diving.

5. All hose whips should be clear of debris and have their open ends taped, capped or plugged when not in use.
6. Flush out low pressure hose whip before connecting to the AMCOMMAND II to prevent debris from entering system.
7. Attach hose whip to LP supply inlet fitting. Note: When tightening, USE TWO WRENCHES place one wrench on inlet fitting and hold, turn hose fitting with a second wrench making sure not to over tighten.

6.2 PRE-DIVE CHECK OUT

1. Be sure both the high pressure valves, pneumo valve, and air supply valves are in the 'off' (closed) position.
2. Regulator should be set to a low pressure, turn knob counter clockwise until the knob stops.
3. Turn the Diver output valves and pneumo valves to 'off' position.
4. With the yoke bleeder valve in closed position, turn on high pressure air at both SCUBA or breathing air cylinders. Note: Always open high pressure valves slowly, allow system to fill slowly before opening valves for maximum flow. Check the pressure level of both HP supply's.
5. Turn on 1 HP supply valve by turning counter clockwise four (4) full turns. **Note:** 2 HP supply valve should be in the off position and used as a back-up.

Caution: If both HP valves are opened at the same time, both air supplies will be used simultaneously. This will result in both bottles being empty at the same time. The purpose of the two supplies is to alternate between the two bottles. Use one of the bottles until it reaches 500 PSI, and then switch to the second bottle. With a full bottle on line, you can then replace the first bottle with a full unit.

6. Note the cylinders air pressure by reading the HP supply gauges.
7. Adjust regulator to desired setting by turning knob while monitoring the diver air supply gauge. Clockwise increases the set pressure.

Note: Regulator setting is determined by: required over-bottom pressure for manufacturer's helmet or mask plus the bottom pressure relating to the diver's depth. See section 10-3 for gauge pressure verses depth chart

6.3 PRE-DIVE PNEUMO TEST

The AMCOMMAND II Pneumo section has gauge protectors to protect the pneumo gauges from over pressurization. However it is good operating practice to use a procedure which will not damage the gauges when operating a system without gauge protectors. Using a standard procedure will permit the operator to use a different system without gauge protectors and operate the system correctly.

A Pneumo gauge with a range of 250 FSW/76 MSW has an equivalent full-scale pressure rating of 111.25 PSI. If you exceed this pressure by a significant amount you will cause a permanent change in the calibration of the gauge. If you exceed 111 PSI by 100% you will destroy the gauge.

Procedure for checking the pneumo gauges:

1. Pressurize the LP section of the AMCOMMAND II; reduce the output pressure of the regulator to a pressure less than 100 PSI.
2. Open the diver output valve momentarily to reduce the pressure and check the action of the regulator. Check to see that the output of the regulator stays at less than 100 PSI.
3. Open Pneumo valve slowly, while watching the depth gauge, check that the gauge needle is slowly rising and that air is exhausting through the diver's pneumo connection (or diver's pneumo hose if connected).
4. Close valve; check depth gauge to see that it reads zero. The gauge should be within +/- 10 feet of zero. Zero will be affected by changes in atmospheric pressure and/or changes in altitude. If zero is off by more than 10 feet and there has not been a significant change in either atmospheric pressure or altitude, suspect that the gauge has been subjected to over-pressurization and may have suffered damage. Cross-check the gauge or have the gauge calibrated before using.
5. Seal the output of the pneumo section. This can be done by capping off the Pneumo output, or preferable sealing the end of the pneumo hose. Pressurize the Pneumo to 200 FSW and close the blow-down valve. This reading should hold, without a decrease in reading. If the reading decreases you have a leak in the system, correct before proceeding.

6. Cross-checking the pneumo gauges. Either connect the pneumo outputs together, or connect the pneumo hoses together and pressurize the system, both gauges should read the same. If the gauges differ by more than 2%, have the defective gauge calibrated. Gauge calibration should be compared at several points over the range of the gauge, with both increasing and decreasing pressure. As a minimum check the gauges over the range which the gauge will be used.

6.4 PRE-DIVE TESTING COMMUNICATIONS

1. Always test the communications between the AMCOMMAND II and divers before each dive. Connect the diver's umbilical to the diver communicator, and the helmet / hat to the umbilical.
2. Turn power to "ON" position.
3. Set "Tenders Volume" at mid-scale. While diver is speaking, adjust to a comfortable level.
4. Set "Divers Volume" at mid-scale. Talk to diver and adjust until diver can hear tender at a comfortable level. If you are using a 2-wire system you must use the "Push-to-talk" switch, or the push-to-talk "Hand held Microphone".
5. Become familiar with the "Push- to -Talk" switch by pushing the switch when talking to the diver. Note: If switch is depressed, tender cannot hear diver. Diver cannot hear tender if tender does not actuate the "Push- to -Talk" switch.
6. Check Diver 2 or the standby diver communication.

6.5 CONNECTING DIVER UMBILICAL

1. Remove protective caps and attach diver air supply and diver pneumo hose fittings to corresponding outlets. Note: When tightening, place one wrench on outlet fitting and one wrench on hose fitting. Tighten hose fitting, making sure not to over tighten.
2. Blow out diver's air supply hose to insure no debris is in the line before connecting to a helmet or mask.

Connect the communication cable (surface end) to the two binding posts located on the right side of radio. Wires should be well fastened to the binding posts and not touching each other (bare wire). We strongly recommend the use of dual banana plugs attached to the top side end of the umbilical. This ensures a good connection and reduces the possibility of shorts and/or intermittent connections. Attach diver's end to helmet or mask.

Test the operation of the system.

6.6 LOW PRESSURE SUPPLY

Test LP supply with low pressure compressor.

Note: Adjust diver air supply pressure at compressor. The AMCOMMAND's LP supply system by-passes the regulator, therefore, cannot control air pressure entering system, or the pressure to the diver.

7 OPERATING PROCEDURES

7.1 LOW PRESSURE BREATHING AIR (PRIMARY SUPPLY)

Low Pressure Compressor (Primary supply), High Pressure (Backup). In this mode of operation the divers breathing air is being supplied by an LP compressor, the HP Supply is use as a back-up supply. Having the HP supply as a backup does not eliminate the requirement for a bailout source of air.

In the event the LP air source fails, it is a simple matter to switch over to HP Air. Turn “ON” the HP source by opening the HP-1 valve. Check the diver’s air supply pressure.

7.2 HIGH PRESSURE BREATHING AIR (PRIMARY SUPPLY)

In this mode of operation the divers breathing air is being supplied by via high pressure breathing air source. This could include SCUBA tanks (singles or twins), high pressure storage cylinders, or a bank of high-pressure storage cylinders.

Caution!

Maximum input pressure limit of 3000 PSI when using standard CGA850 yokes.

Maximum input pressure limit of 4500 PSI when using optional 300 Bar DIN adapters.

The High Pressure breathing system is designed to allow the rotation of bottles as they are consumed. Operate the system using a single bottle until the bottle pressure has dropped to approximately 500 PSI, then switch to the next bottle. Repeat this procedure alternating between HP-1 and HP-2, changing bottles as they are used. The HP input system has check valves, which prevent back-flow between the bottles. This facilitates switching between bottles.

Example:

If you have two bottles connected to the system and you are using bottle HP-1, bottle HP-2 is “OFF”, when HP-1 reaches 500 PSI, you may switch to HP-2 by opening the valve for HP-2. The system will draw air from the higher of the two sources, HP-2. You can then turn HP-1 “OFF”, and change the bottle connected to source HP-1. This procedure ensures an uninterrupted supply of air to the diver.

After turning HP-1 off, turn the bottle valve off, open bleed-valve on the yoke and bleed the pressure. Release the yoke and replace the empty bottle with a full bottle. Close the bleed-valve and turn SCUBA cylinder on and verify the bottle is full.

Another method of changing bottles is to leave both valves on the system in the “ON” position. Use the SCUBA bottle valves as the ON/OFF control for selecting which bottle is in use. This reduces the number of valves, which must be open and closed for each change of bottles. If you use this procedure, you should monetarily open the new bottle and check the gauge to ensure the bottle is full, then close bottle to prevent the system from using air from both bottles at the same time.

1. When planning your dive you must take into consideration the amount of time a given bottle will last and the number of bottle changes, which will be necessary during the dive. There are two options that can be used to accommodate dives that will have a high consumption of air.
2. Use twin tanks instead of singles. Use a high volume cylinder (250 - 300 cubic feet) of breathing air; these can generally be rented from a welding gas supplier, or supplier of industrial gases. Make sure you specify breathing air, and request certification. These cylinders can be also be manifolded quite easily. Generally the charge for rental is very competitive in cost and usually includes delivery to the job site.

Note: When using high-pressure cylinders, care must be exercised in the handling, transport and storage of it. Make sure all personnel involved are instructed in the proper procedures. If you have any questions regarding the proper procedures contact your supplier.

7.3 PRE-OPERATION CHECKLIST

1. Diver dressed and ready except helmet / hat
2. Diver's umbilical organized
3. LP Compressor running and at pressure
4. LP Alarm in “ON” position
5. HP source connected and ready, HP-1 and HP-2 valves “OFF”
6. Zero Pneumo Gauges
7. Diver air ON, purge diver helmet / hat
8. Diver dons helmet / hat
9. Diver communicator ON, Comm check
10. Diver air check
11. Diver enters water
12. Record the starting time of the dive

During the dive, the tender shall maintain voice communication with the diver at all times. Tender shall monitor diver's air pressure and breathing rate.

7.4 PNEUMO READINGS

During the dive, the tender shall monitor the diver's depth, recording the depth and time at depth. The procedure for measuring depth is as follows.

Advise the diver that a pneumo reading is to be taken.

The diver will place the end of the pneumo hose at the point at which the measurement shall be taken. Diver will advise the tender he is ready for the pneumo reading.

Slowly open the Pneumo valve corresponding to the diver whose depth is being measured. The Pneumo gauge reading will increase and stabilize at a value greater than the depth of the diver. The value will depend upon the flow rate, and pressure drop over the length of the pneumo hose. The diver will advise the tender of bubbles coming from the end of the hose.

Close the pneumo valve, the reading will decrease to the value of the diver's depth. Once the reading has stabilized, this is the depth at the end of the pneumo hose.

Note: Pneumo readings can be used for several purposes i.e., measuring the diver's depth, depth to a particular point under water, vertical distance from one underwater object to another. The accuracy of the measurement is plus or minus 0.625 feet of seawater, (+/- 7.5 inches). This represents an overall accuracy of +/- 1/4 of 1% of the full-scale value of the depth gauge. To maintain this accuracy the gauges must be calibrated every 6 months.

When using the pneumo system to measure the diver's depth for use in determining decompression requirements, please note the following:

7.4.1 Definitions of terms, PAR 7.1

DEPTH - When used to indicate the depth of a dive, it means the maximum depth attained by any part of the diver during the dive, measured in feet of seawater.

7.4.2 Selection of decompression Schedule, PAR 7.2.3

1. Always select the schedule depth to be equal to or the next depth greater than the actual depth to which the dive was conducted, and
2. Always select the schedule bottom time to be equal to or the next longer bottom time than the actual bottom time of the dive.

7.4.3 Rules during ascent, PAR 7.4.1

Decompression Stop Depth - The diver's chest should be located as close as possible to the stop depth.

The above information is quoted from the U.S. NAVY DIVING MANUAL, Chapter 7, Air Decompression.

7.5 DIVER COMMUNICATIONS

The AMCOM SERIES II can be operated in two basic modes of operation. The conventional method of operation is known as 2-wire, this allows the diver to be heard by the tender, but requires the operator/tender to actuate the Push-To-Talk switch in order to talk to the diver. The modern method of operation allows two way conversations to be carried on simultaneously. Amron calls this method of operation "FULL DUPLEX". The diver and tender can talk to each other as you would on a telephone. The same applies to diver to diver conversations. Amron tries to encourage the use of FULL DUPLEX for superior communications and safety.

The Model 2825A Series has the capability of 2-wire and/or FULL DUPLEX (4-wire) communication modes. FULL DUPLEX and 2-wire can be used simultaneously (mixed), divers on FULL DUPLEX, tender on 2-wire.

2-wire communication is defined as a single communication path. The diver is the priority signal path, tender listens to diver. Signal reversing is accomplished by pushing the Push-To-Talk switch; diver hears tender. Often times a 4-conductor (4 wires) common cable is used with two wires tied together as a pair (this is done for redundancy.), however this is still a 2-wire system.

FULL DUPLEX communication is defined as a dual communication path; a signal path (a pair of wires) for up-link and a signal path (a pair of wires) for down link. A common example of FULL DUPLEX like communication is the telephone. This permits the freedom of natural communication, lower system noise, and diver to diver communication without having to attempt Crosstalk switching.

7.6 2-WIRE OPERATION (REFER TO FIGURE 3)

1. Connect the comm cable from the divers to Diver 1 and/or Diver 2, Microphone (inputs) under the words "2-wire". Wires should be well fastened to the binding posts and not touching each other. A good method of attachment is to use a dual banana plug (AMRON P/N 14001B). If more than one diver is connected to any microphone (input), (Diver 1 or Diver 2), those divers on the same two terminals will not be able to crosstalk.

The earphone connection is not used by the divers. The earphone jacks can be used to operate a remote speaker; both diver and tender conversations will be heard.

2. In 2-wire, the tender must press the Push-To-Talk switch to be heard. If you are using the (optional) AMRON Remote Walk and Talk, Model 2821-28, the tender may press the Push-To-Talk switch on the belt module.

7.6.1 Volume Controls - Set all volume controls to mid-scale.

1. Tender
 - i. Divers to Tender – Adjust to comfortable level
 - ii. Tender to Divers – Adjust to comfortable level
2. Diver 1
 - i. Divers to Tender – Adjust to comfortable level
 - ii. Tender to Divers – Adjust to comfortable level
3. Diver 2
 - i. Divers to Tender – Adjust to comfortable level
 - ii. Tender to Divers – Adjust to comfortable level

7.7 DIAGRAM, 2-WIRE SET-UP

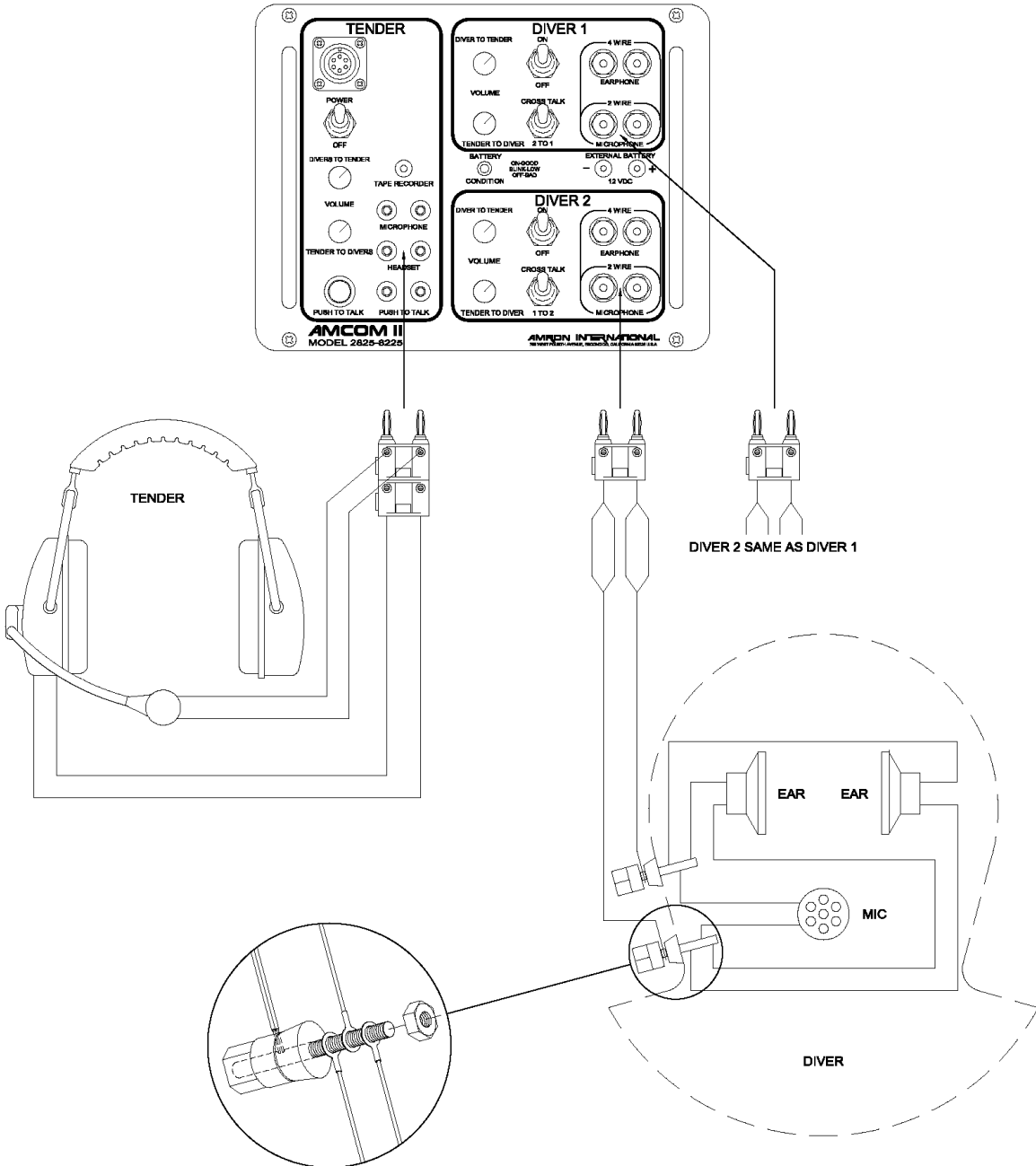

7.8 FULL DUPLEX (4-WIRE) OPERATION (REFER TO FIGURE 4)

1. Connect the two wires from the diver's microphone to the 'Microphone (Input) Diver'
2. Connect the two wires from diver's earphones to the 'Earphone (Inputs) Diver 1'.
3. Repeat the same for Diver 2.
4. Connect tender headset earphones (black dual banana plug) to headset (input).
5. Connect headset microphone (red dual banana plug) to tender microphone.
6. Turn speaker off to avoid acoustic feedback.
7. Operation with speaker is possible by extending tender's headset away from the speaker. Use AMRON Model 2822-28 headset extension cable (25 foot).

Note: When operating with a standby diver who does not have his helmet / hat on, acoustic feedback (squeal) may occur. This can be avoided by turning his volume down (Diver to Tender), which cuts off his microphone, yet will enable him to monitor the diver/tender conversation through his helmet / hat earphones. Or you can disconnect (UN-plug) his microphone circuit that will disable his microphone.

7.8.1 Volume Controls

Set all volume controls at mid-scale. Tender should don headset and talk to himself. If adjustments are required, increase or decrease volume (controls). This will establish a system volume level.

7.8.2 Tender Volume Controls

1. Divers To Tender - Use as a master control.
2. Tender to Divers - Use as a master control.

If conditions change as a group, the tender volume controls can be used as master volume control.

7.9 DIAGRAM, FULL DUPLEX (4-WIRE)

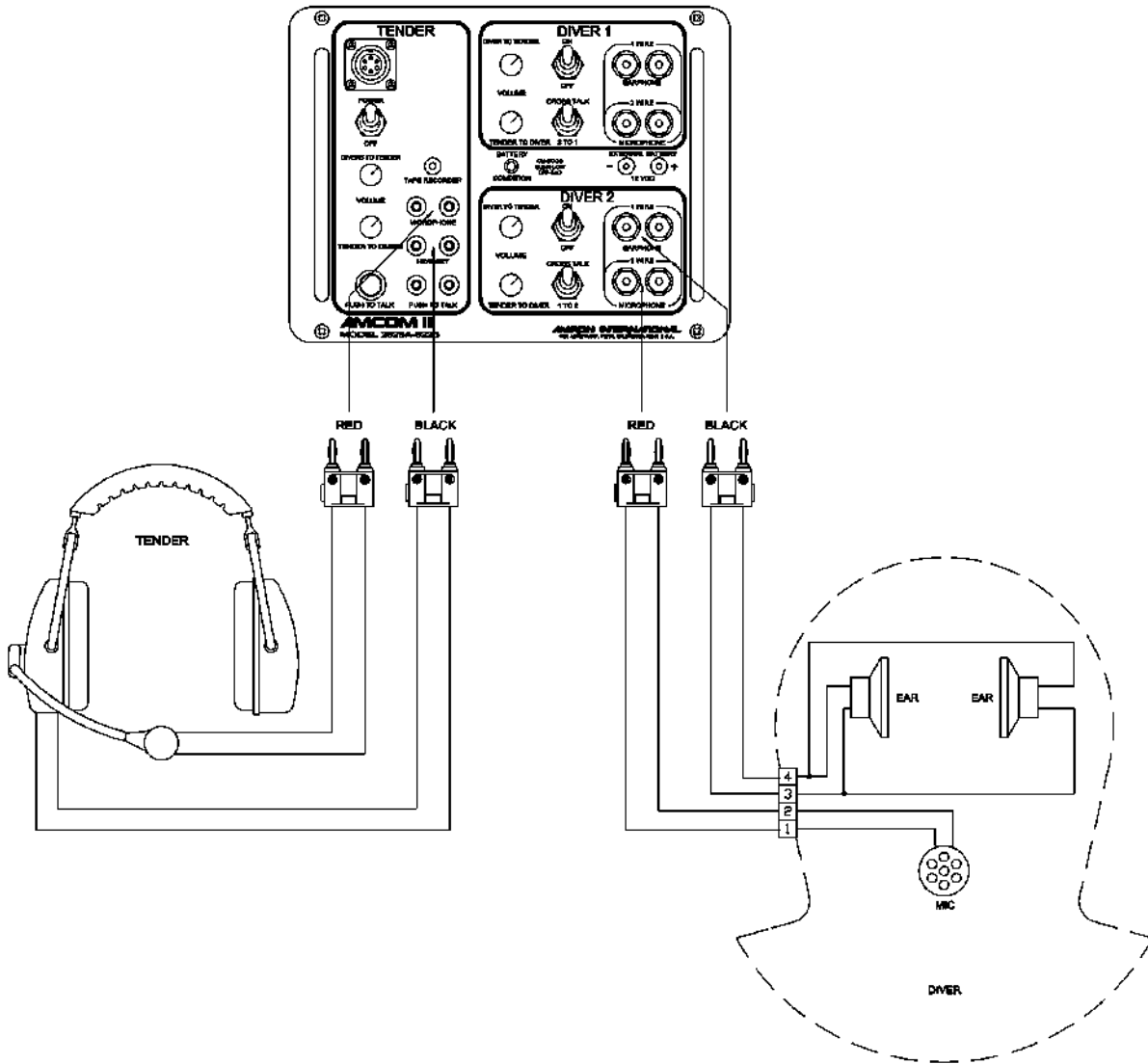

7.10 FLOW DIAGRAM

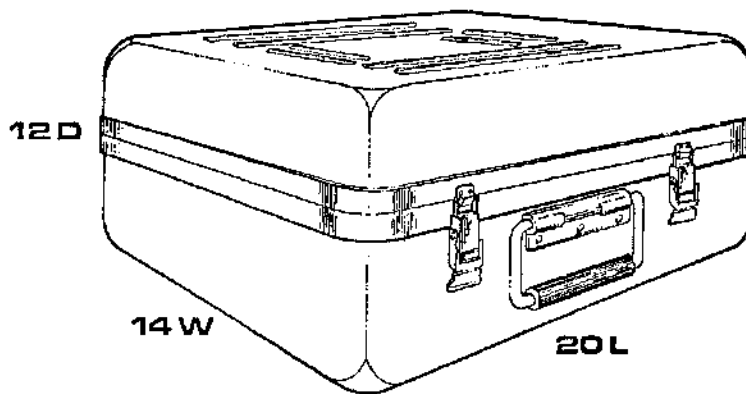
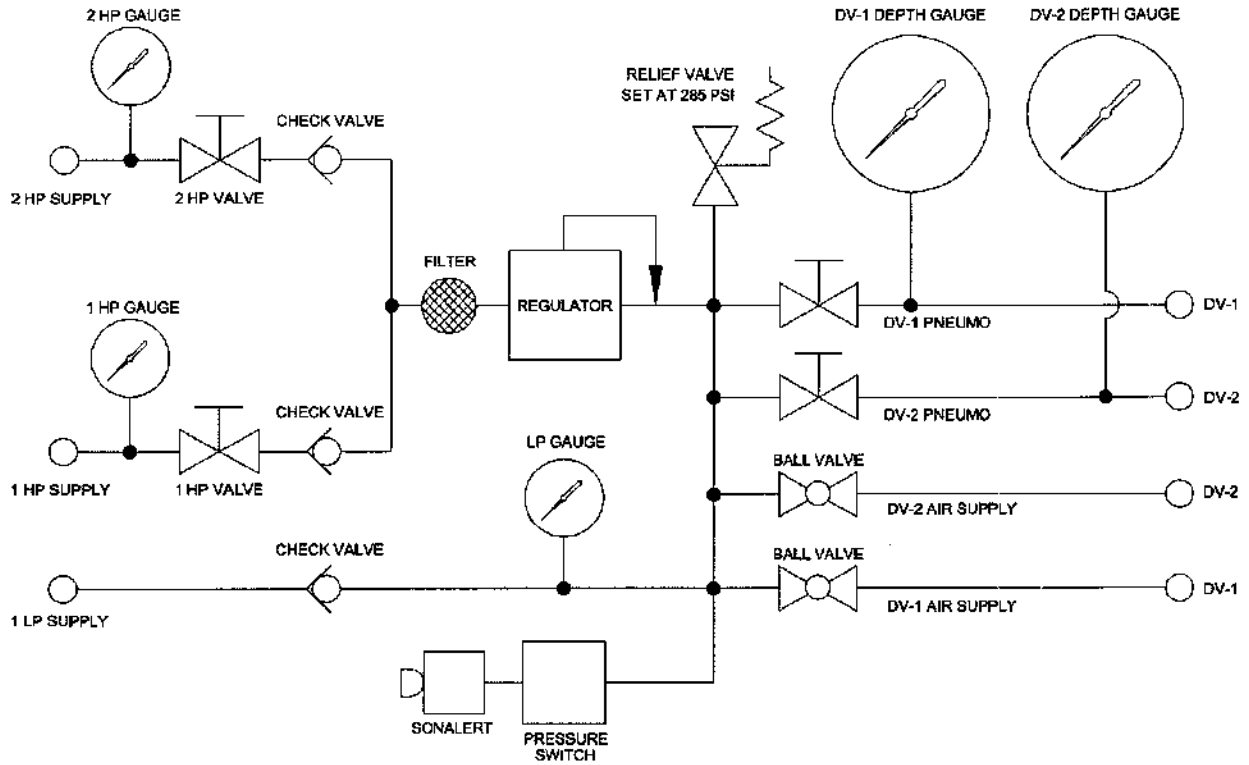

8 MAINTENANCE

8.1 REVIEW OF SCHEDULED MAINTENANCE

1. The inherent quality of your AMCOMMAND II will provide years of continuous failure-free service if properly used and maintained.
2. Before and after each dive: do Functional test, clean and inspect for damage.
3. Every 6 months: calibrate, functional test, clean and inspect for damage.
4. Every 12 months: in addition to the normal 6-month maintenance, service filter, leak test and check adjustments.
5. Every 36 months: in addition to the normal annual service replace all seals, gaskets, soft goods, and batteries.

In addition to the above scheduled maintenance, there are three important areas of user care that will determine the length of service you can expect from your equipment.

1. Take care of your equipment, protect it, and handle it with care during transportation to the job site. Ensure the equipment is protected. Select a work area where the equipment will be out of everyone's way, so that it isn't knocked over.
2. Clean your equipment. After the work is done at the job site, clean up the equipment. If you are on an extended work program, have the equipment operators clean the equipment during slow work periods. Cleaning involves wiping off the dirt with hot soapy water and a soft cloth. Soft Scrub, paint thinner, mineral spirits & turpentine can be used, if necessary, to clean only the case. Clean the terminals (diver communicator connections), using a solution of mild vinegar and a small brush.
3. Charge the batteries after each use; preferably leave the unit on charge when the equipment is not in use.

8.2 SCHEDULED MAINTENANCE

1. Before and after each dive: inspect for any damaged parts, broken gauges, condition of high-pressure hose whip (inspect for cuts, abrasion, or general deterioration). Functional test of unit prior to dive, after dive record operator comments regarding maintenance required.
2. Every 6 Months: complete the before and after each dive inspection. Each diver pneumo gauge must be calibrated. Calibrate against dead weight tester or reference gauge. Pressure test PNEUMO section and repair any and all leaks. Record the results of inspection and gauge calibration.

Every 12 months: complete the above tests plus the following:

1. Remove high-pressure valve stems, inspect, clean, lubricate (use Christo-Lube grease, Amron part No. MCG-111-20Z) and install. Check valve seat, threads, packing material for signs of wear or deterioration, replace if necessary.
2. Remove filter element and inspect. If filter element is dirty, make a determination as to where the contamination is coming from. Check the air source being used to determine where the contamination is coming from and correct. If filter is contaminated, remove high pressure section and clean all valves, inspect for signs of wear and deterioration, replace those parts which show signs of deterioration, clean and reassemble.
3. Check regulator action, check regulator maximum pressure which should be greater than 265 PSI.
4. Check relief valve actuation and shut off. Should vent at 285 PSI, close at 280 PSI sealing bubble tight.
5. Check action of pneumo gauge protectors, should shut off at 122 +/- 5 PSI on slow rising pressure.
6. Check operation of LOW-PRESSURE alarm, adjust if necessary. Should turn on at 100 +/- 5 PSI, turn off at 110 +/- 5 PSI.
7. Check all valves for bubble tight shut off. Replace seats as needed.
8. Leak test all fittings, Pressure test PNEUMO section.
9. Check accuracy of all gauges.
10. Record the results of the above tests.

Every three years, in addition to the above test:

1. Replace all soft goods, seals, gaskets and batteries.
2. Record the results of the above tests.

9 TROUBLESHOOTING AND REPAIR

9.1 GENERAL INFORMATION

Normal shop tools and procedures apply for all repairs.

During this section when you are instructed to remove a part or make an adjustment, you are first to remove all pressure from the system, or as a minimum from the section you are working on.

9.1.1 Tubing and Tube Fittings

Repair, assembly, and inspection procedures. The common cause of leaks on tube fittings are debris, cracks, and deformed tube flares. Tube fittings, on initial make up tighten 1-1/4 turns from finger tight. To remake tube fittings, tighten finger tight plus 1/8 turn. Care must be used when disassembling tube fittings to ensure the fitting is held while the tube nut is turned.

9.1.2 Pipe Fittings

An over tightened pipe fitting is the most common cause of leaks. Before installing pipe fittings, remove all old Teflon tape, use stiff bristle brush. Replace Teflon tape by wrapping 1-1/2 turns of 1/2 inch tape, counter-clockwise on the threaded portion of the fitting. Use care when installing Teflon tape, leave one full turn of thread exposed and uncovered. This insures that a piece of tape is not cut off and enter the system during the installation of the fitting.

9.1.3 To Remove a Panel

From the case (either the upper, lower, or communicator), first disconnect the electrical cable from the communicator and the pneumo hose from the lower panel. Turn the MS connector on the communicator counter-clockwise to loosen. When the locking ring is turning free, pull up on the connector to remove. You will also need to remove the air hose connecting the lower panel to the upper panel. Loosen the fitting on the lower panel, use two wrenches, and disconnect the hose.

9.1.4 Remove the Diver Communicator

Before attempting to remove the lower panel, loosen and remove the four screws on the front panel of the communicator. Lift communicator out of panel and set aside. Remove the lower panel by removing the screws from around the perimeter of the panel. The lower panel can now be removed from the case. When the lower panel is removed, the case will want to tip over backwards because of the unbalanced weight, support the upper panel or remove the stay hinge and lay the upper panel down.

9.1.5 Removing the Upper Panel

This is the same procedure as the lower. To install the panel back in the case, install all screws before tightening any of the screws. This allows the panel to be shifted to facilitate the alignment of the screw holes in the panel.

9.2 AIR CONTROL

9.2.1 HP Gauges

Inspect for leaks. Any leak other than the input fitting is cause to replace the gauge. Internal leaks may cause the gauge face to bulge, if this occurs replace gauge. Inspect gauge blow-out plug for damage. Check accuracy of gauge against reference gauge. Gauges are not repairable, nor can they be adjusted. Discard and replace if problems are encountered.

9.2.2 HP Valves

These are repairable. Remove stem by removing handle and stem packing nut, unscrew stem. Inspect stem, stem screw threads, valve body screw threads, brass packing washer, Viton O-ring, and stem seat (KEL-F). Repair kits are available and include a complete stem assembly. Lubricate stem screw threads and Viton O-ring with Christo-Lube grease, install stem assembly, and permanently tighten packing nut.

9.2.3 HP Check Valves

These are repairable. The Maintenance Kit is available from Amron and contains Viton seat and spring. When checking for leaks, be sure to check valve body to end of fitting.

9.2.4 HP Filter

This is a replaceable element. The Maintenance Kit is available from Amron and contains the element, body gasket, and retainer spring. Check with soap and water to ensure filter is not leaking.

9.2.5 HP-Regulator

Problems and their possible causes. Refer to figure while reading this section. If the regulated pressure continues to rise at lock-up with no change in the control knob setting, suspect damaged or dirty main valve seat (item 20) or damaged valve stem (item 18). Bleed inlet pressure and inspect seat and valve stem by removing back cap (item 13), an audible leak through bonnet (item 8). Check torque on bonnet ring (item 6) and diaphragm nut and inspect diaphragm (item 11) for damage or excessive wear. If outlet pressure drops off rapidly with very small flow demand, check that valve stem support (item 22) has not been inadvertently left out after previous disassembly or that filter has not been clogged by and excessively contaminated supply.

9.2.6 Repair Kits

Repair kits are available in two configurations. Soft goods repair kit, P/N 389-6906 includes items 11 diaphragm, 14 O-ring, 15 O-ring, and 20 seats. The Standard repair kit, P/N 389-6907 includes all the items in the soft goods kit and the following items, 7 washer, and 18 valve stem.

9.2.7 **Disassembly and assembly of the Regulator**

1. Remove regulator from system.
2. Turn CONTROL KNOB (item 3) counter-clockwise to insure removal of all spring force on the DIAPHRAGM (item 11).
3. Secure regulator in vise with the BACK CAP (item 13) on the bottom.
4. Remove mounting bracket (item 5).
5. Remove BONNET RING (item 6). DIAPHRAGM (item 11) and associated parts can now be disassembled.
6. Remove BACK CAP (item 13) by using 1-1/8" wrench. Valve stem (item 18) and associated parts are removed with the back cap.
7. The above steps provide the disassembly procedures. To reassemble, simply reverse these procedures. Torque Diaphragm nut to between 45-50 inch pounds, and the Bonnet Ring to between 50-55 foot pounds. Lubricate the O-rings, bonnet ring and back cap.

9.2.8 **Relief Valve**

Check the operation of the vent valve by pressurizing the system until the vent begins to relieve the pressure. Decrease the pressure to stop the venting action, valve should stop bubble tight. If the relief valve does not operate correctly remove and disassemble, inspect. Replace any defective parts or clean, lubricate and reassemble.

To disassemble the relief valve, remove valve from system. In the output side of the valve there is a set screw, remove it. There is a second set screw under the first screw. The second set screw is the actual adjustment for the set point. The first screw is a locking screw that locks the adjusting screw at the set point.

There is another set screw at the other end of the valve, removing this allows the valve to be completely disassembled. When taking the valve apart be sure to lay the parts out in the order in which they were removed to facilitate assembly. Reverse the order to assemble. Pressurize the valve to check the setting of the valve. Remove the pressure and adjust as necessary to set the pressure. Turning the screw clockwise increases the pressure at which the valve will relieve.

9.2.9 **LP Input check Valve**

Same as the HP check valves except for size. During test, insure that the valve is not leaking by pressurizing the HP section and check the LP input for air leaking out of the input.

9.2.10 **Diver's Pressure Gauge**

Same as HP pressure gauges.

9.2.11 Diver's Output Valves

¼ turn ball-valves, to test, pressurize the input and turn the valves off, check that no air is leaking past the valve. The valves are repairable. They use Teflon seats which can be replaced. A maintenance kit is available from Amron. To replace, remove valve from system. Remove end pieces from valve, remove valve stem packing nut and remove stem. Teflon ball seal and stem packing can now be removed and replaced. To assemble, reverse the process.

9.3 DEPTH MONITORING

9.3.1 Pneumo Valves

Pneumo Valves are repairable. Remove stem by removing handle and step packing nut. Unscrew stem. Inspect stem, stem screw threads, valve body screw threads, brass and Teflon packing washer, and stem seat (KEL-F). Repair kits are available and include a complete stem assembly. Lubricate stem screw threads with Christo-Lube grease, install stem assembly and permanently tighten packing nut.

9.3.2 Pneumo Gauge Protector

Pneumo gauges are not field repairable nor are there any adjustments which can be made in the field. Check to make sure the blow-out plugs are in place. Calibrate every 6 months. Check the zero position of the gauge; a displaced zero is evidence of a gauge that has been subjected to over-pressurization.

9.3.3 Pneumo Gauges

Pneumo gauges are not field repairable nor are there any adjustments which can be made in the field. Check to make sure the blow-out plugs are in place. Calibrate every 6 months. Check the zero position of the gauge, a displaced zero is evidence of a gauge that has been subjected to over-pressurization.

Note: Check the gauge before using. If there is any question about the gauges integrity, have the gauge calibrated. Normal variations in zero are caused by variations in barometric pressure or changes in altitude. These variations normally will not exceed 10 feet.

9.3.4 Low Pressure Alarm

To adjust the set point of the low pressure alarm, loosen the locking ring on the pressure switch. Rotate the body of the switch clockwise to increase the set pressure. The set point of the switch is very sensitive to adjustment and requires patience and a steady hand. Tighten lock and recheck set point. Variation between increasing pressure and decreasing pressure trip points is about 15 PSI. Check the set point in the decreasing direction.

9.4 DIVER COMMUNICATIONS

9.4.1 Diver Radio Field check Procedures

The following are procedures to allow a functional check in the field of your radio, using only a headset. These steps check all communication functions of the radio in both 2-wire and Full Duplex modes. This means that if your radio checks with these steps, any communication problems should be somewhere else in the system, such as the umbilical, connections, speakers and/or microphone.

9.4.2 Quick Full Duplex Check

1. Identify headset microphone lead and headset earphone lead. Plug into dual banana jack adapters (usually the microphone plug is red).
2. Plug in headset microphone to “Tender” “Microphone” (input) and headset earphone to “Tender” “Headset” (input/output). You should be able to hear yourself talk. This verifies Tender circuit.
3. Move headset microphone to “Diver 1” “Microphone” (input) and headset earphones to “Diver 1” “Earphone” (output). You should be able to hear yourself talk. This verifies Diver 1 circuit.
4. Move headset microphone to “Diver 2” “Microphone” (input) and headset earphones to “Diver 2” “Earphone” (output). You should be able to hear yourself talk. This verifies Diver 2 circuit.

9.4.3 Comprehensive 2-Wire and Full Duplex Check

1. Set all volume controls at mid-scale, turn power on.
2. Identify headset microphone lead and headset earphone lead. Plug into dual banana jack adapters (usually the microphone plug is red.)
3. Plug headset earphone into “Tender” “Headset” (output) and the headset microphone into “Tender” “Microphone” (input). Turn power on, speaker off. Put on headset and speak into microphone, listening for your own voice. Adjust Diver-to-Tender volume; check that controls respond and that there is adequate volume. If you can talk to yourself, then Tender circuit is operating properly

9.4.4 “Diver 1” Down-link Check

1. Move headset earphone plug from “Headset” (output) to “Microphone” “Diver 1”. Talk into headset while pressing the Push-to-Talk switch. You should be able to talk to yourself with plenty of volume as long as the Push-to-Talk switch is depressed. This verifies 2-wire communication from tender to “Diver 1” and the function of relay K1.
2. Move headset earphone plug from “Microphone” (input) “Diver 1” to “Earphone” (output) “Diver 1”. Talk into headset. There should be plenty of volume. This checks earphone output for Diver 1, Full Duplex.

9.4.5 “Diver 2” Down-link Check

Move headset earphone plug from “Diver 1” “Earphone” (output) to “Microphone” (input) “Diver 2”. Talk into headset while pressing the Push-to-Talk switch. You should be able to talk to yourself with plenty of volume as long as the “Push-to-Talk switch is depressed. This verifies 2-wire communication from Tender to Diver 2 and the function of relay K2.

Move headset earphone plug from “Microphone” (input) “Diver 2” to “Earphone” (output) “Diver 2”. Talk into headset. There should be plenty of volume. This checks earphone output for Diver 2, Full Duplex.

9.4.6 Tender’s Speaker Down-link Check

Unplug headset from “Microphone” (input) and turn “Speaker” on. Press Push-to-Talk and talk into speaker. You should hear yourself in the headset earphones. This verifies speaker section of relay K1. Turn speaker off.

9.4.7 “Diver 1” Up-link Check

Place headset microphone into “Microphone” (input) “Diver 1” and headset earphone plug in “Tender” “Headset” (output). Talk into headset. You should hear yourself in the headphones with plenty of volume. Press “Diver 1” On/Off while talking. When switch is depressed, your voice should cut out. This verifies “Diver 1” “Microphone” (input), relay K1 and “Diver 1 On/Off switch.

9.4.8 “Diver 2” Up-link Check

Move headset microphone into “Microphone” (input) “Diver 2”. Talk into headset. You should hear yourself in the headphones with plenty of volume. Press “Diver 2” On/Off while talking. When switch is depressed, your voice should cut out. This verifies “Diver 2” “Microphone” (input) relay K1 and “Diver 2” On/Off switch.

9.4.9 Crosstalk Check

Move headset microphone plug to “Microphone (input “Diver 1”. Press “Crosstalk DV-2 to DV-1 switch and talk into headset. You should hear yourself while the “Crosstalk” switch is depressed. This checks the “Crosstalk” function Diver 2 talking to Diver 1.

Move headset microphone plug to “Microphone” (input) “Diver 2; move headset earphone plug to “Diver 1” “Microphone” (input). Press “Crosstalk 1 to 2” switch and talk into headset. You should hear yourself while the “Crosstalk” switch is depressed. This checks the “Crosstalk” function Diver 1 talking to Diver 2.

9.5 PROBLEMS AND THEIR POSSIBLE CAUSES

9.5.1 Unit Does Not Operate

Check to see that unit is turned on (speaker and headset switch). Check that battery condition is okay, (battery condition indicator). Check to see that connections are proper; correct if necessary. Use diver radio field check procedure to determine if problem is within the unit or elsewhere within the communication system. Check to see that internal P.C card connectors are properly seated. There should be no gap between the bottom of the connector housing and the circuit card. Push connector down and recheck.

9.5.2 Low Volume

Check volume control settings, adjust if desired. Check diver connections, correct if bad. Use diver radio field check procedure. Check for low batteries.

9.5.3 Garbled Voice to Diver

The Diver volume to Tender is set too high; reduce volume. Tender's headset is marginal, speaker has water in it and Diver's microphone is marginal, damaged comm cable or connections; substitute with known good units to determine exact problem and correct.

9.5.4 Garbled Voice to Tender

The Diver volume to Tender is set too high; reduce volume. Tender's headset is marginal, speaker has water in it, and Diver's microphone is marginal, damaged comm cable or connections; substitute with known good units to determine exact problem and correct.

9.5.5 Diver Cuts Out

Check for intermittent connection; substitute system components with known good units to determine exact problem and correct fault.

9.5.6 Connections

Most diver communications problems are caused by bad connections. The time spent in making good connections will result in years of good communications. All connections must be soldered to last for any period of time. Copper wire must be tinned as a minimum. It is strongly suggested that dual banana plugs be used for topside connections. This provides a convenient and secure connection which will last for several years if treated with a reasonable amount of care.

All cable splices must be soldered. Splices should be staggered, covered with shrink tubing, preferably shrink tubing with an adhesive sealant, and a general splice cover to protect the connections. Potting of splices is a very good and professional approach, however not necessary to create a reliable splice.

9.5.7 Push-to-Talk Does Not Function but Tender Hears Diver (2-Wire)

Check connection to tender headset microphone if used. Check battery condition indicator to be steady green. The first function to fail because of low batteries is the actuation of the push-to-talk function. Find which push-to-talk switch is not working (PTT All Divers, PTT Diver 1 & PTT Diver 2). It could be a broken wire on the switch terminals or a bad connection with PC card.

9.5.8 Diver Hears Tender but Tender Cannot Hear Diver (or volume is very low)

Check to see if Diver is connected to microphone and not earphone. Check to see that volume levels are not turned down. Inspect Diver connections and hat components.

9.5.9 Feedback

These situations may cause feedback: Tender's speaker on while headset is connected; unused Diver communications connected to system; damaged comm cable or connections (open or shorted wires or connections). Feedback can be caused by leakage between microphone wires and earphone wires in the umbilical. Leakage can be determined by a continuity test between the wires. Resistance for a new cable should be in excess of 10Meg ohms. In a situation where the comm cable is damaged, reduce the volume to diver as low as possible (reduce side tone), or go to 2-wire operation until cable can be repaired.

9.5.10 Distortion

Distortion may be caused by several conditions: Volume is adjusted too high; system is on the verge of feedback; marginal components (earphone or microphone). Check by substitution, replace defective components. Note: when operating with standby Diver who does not have his helmet / hat on, acoustic feedback or distortion may occur. Correct by turning his volume down or disconnecting his comm cable (at least his microphone, which will reduce overall system noise).

10 REFERENCE MATERIAL

10.1 DIVING LOG, U.S NAVY (CHART)

DIVING CHART - AIR						Date
NAME OF DIVER 1		DIVING APPARATUS		TYPE DRESS		EGS (PSIG)
NAME OF DIVER 2		DIVING APPARATUS		TYPE DRESS		EGS (PSIG)
TENDERS (DIVER 1)			TENDERS (DIVER 2)			
LEFT SURFACE (LS)		AND DEPTH (fsw)		REACHED BOTTOM (RB)		DESCENT TIME
LEFT BOTTOM (LB)		TOTAL BOTTOM TIME (TBT)		TABLE & SCHEDULE USED		TIME TO FIRST STOP
REACHED SURFACE (RS)		TOTAL DECOMPRESSION TIME (TDT)		TOTAL TIME OF DIVE (TTD)		REPETITIVE GROUP
DESCENT	ASCENT	DEPTH OF STOPS	DECOMPRESSION TIME		TIME	
			WATER	CHAMBER	WATER	CHAMBER
	↑	10			L	
	↑	20			R	
	↑	30			L	
		40			R	
		50			L	
		60			R	
		70			L	
		80			R	
		90			L	
		100			R	
		110			L	
		120			R	
	↓	130			L	
PURPOSE OF DIVE				REMARKS		
DIVER'S CONDITION				DIVING SUPERVISOR		

10.3 NO DECOMPRESSION LIMITS

(Non-repetitive Dives Only) U.S. Navy Diving Manual (Air Decompression)

Depth FSW	Bottom Time
40	200
50	100
60	60
70	50
80	40
90	30
100	25
110	20
120	15
130	10
140	10
150	5
160	5
170	5
180	5
180	5

NOTE: OSHA Regulations Require: A decompression chamber capable of recompressing the Diver at the surface to a minimum of 165 FSW (6ATA) and shall be available at the dive location for: A) surface supplied air-diving to depths deeper than 100 FSW.

10.4 GAUGE PRESSURE FOR DEPTH OF SEAWATER & FRESHWATER

Gauge Pressure in PSI

Depth FSW	Bottom Time	Seawater
10	4.33	4.45
20	8.66	8.90
30	12.99	13.35
40	17.32	17.80
50	21.65	22.25
60	25.98	26.70
70	30.31	31.10
80	34.64	35.60
90	38.97	40.05
100	43.30	44.50
110	47.63	48.95
120	51.96	53.40
130	56.29	57.85
140	60.62	62.30
150	64.95	66.75
160	69.28	71.20
170	73.61	75.65
180	77.94	80.10
190	82.27	84.55
200	86.60	89.00

10.5 EQUIVALENT DEPTHS OF SEAWATER & FRESHWATER

Depth	Equivalent Depth
Feet of Seawater	Feet of Fresh Water
10	10.3
20	20.3
30	30.9
40	41.2
50	51.5
60	61.8
70	72.1
80	82.4
90	92.7
100	103.0
110	113.3
120	123.6
130	133.9
140	144.2
150	154.5
160	164.8
170	175.1
180	185.4
190	195.7

11 DRAWINGS AND SCHEMATICS

General

The following drawings illustrate the electrical and mechanical details of the diver communication unit. The corresponding parts lists for each drawing are detailed in the parts lists section.

Revisions

As drawings are updated, information about changes is incorporated into a revision sheet. This revision sheet appears in the manual immediately after the drawings. It lists the drawing number, the reference designator of the part or parts involved, a description of the revision, and the effective serial number of the change. With this information, the technician can determine the correct drawing for the current version and any previous version(s) of the unit covered by this manual. If the revision is applicable for all versions of the unit, it is not included in the revision notice, as the change applies to all units.

11.1 PARTS LOCATOR, 8225 SERIES PNEUMO PANEL (FRONT VIEW)

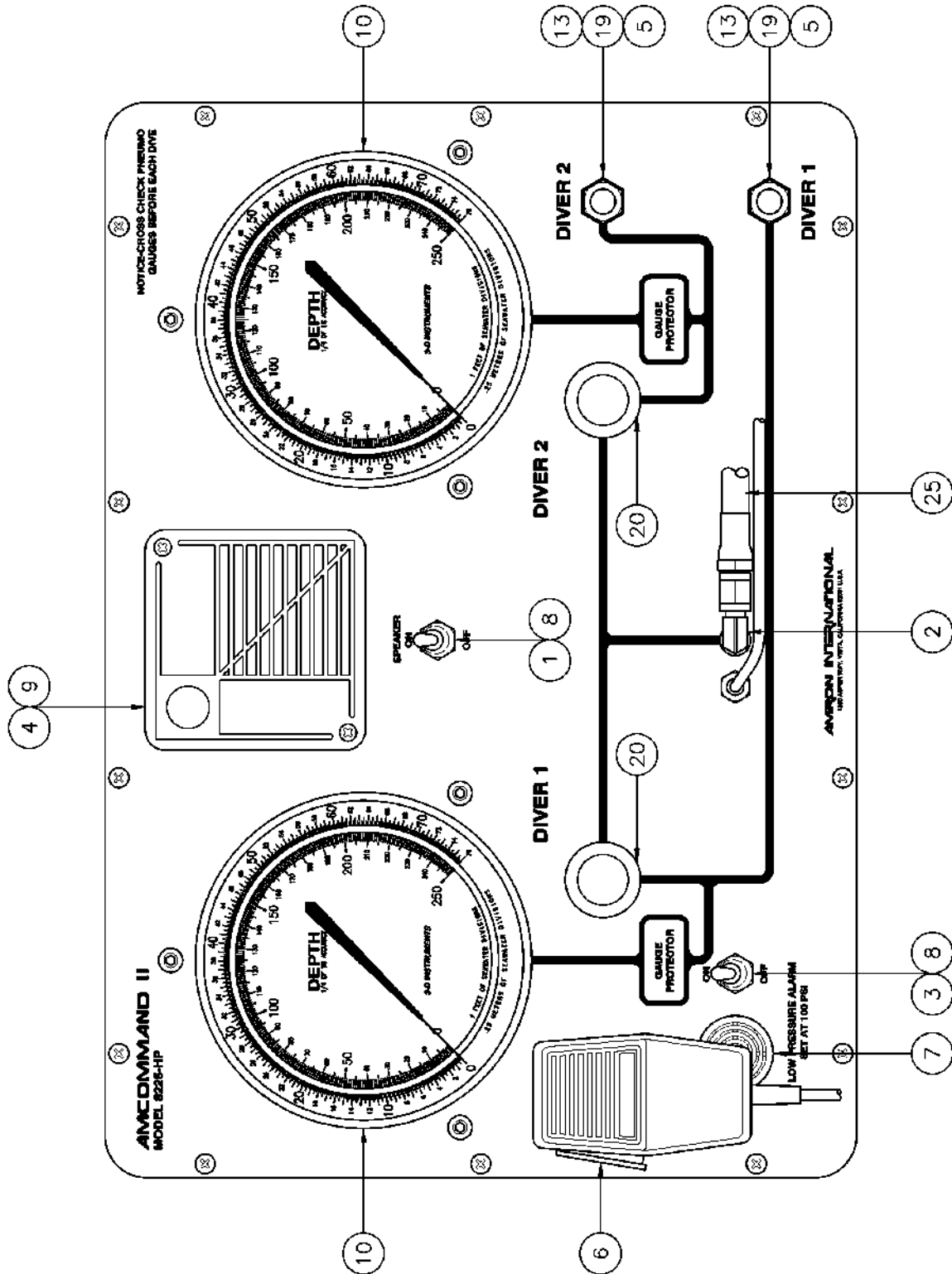

11.2 PARTS LOCATOR, 8225 SERIES PNEUMO PANEL (REAR VIEW)

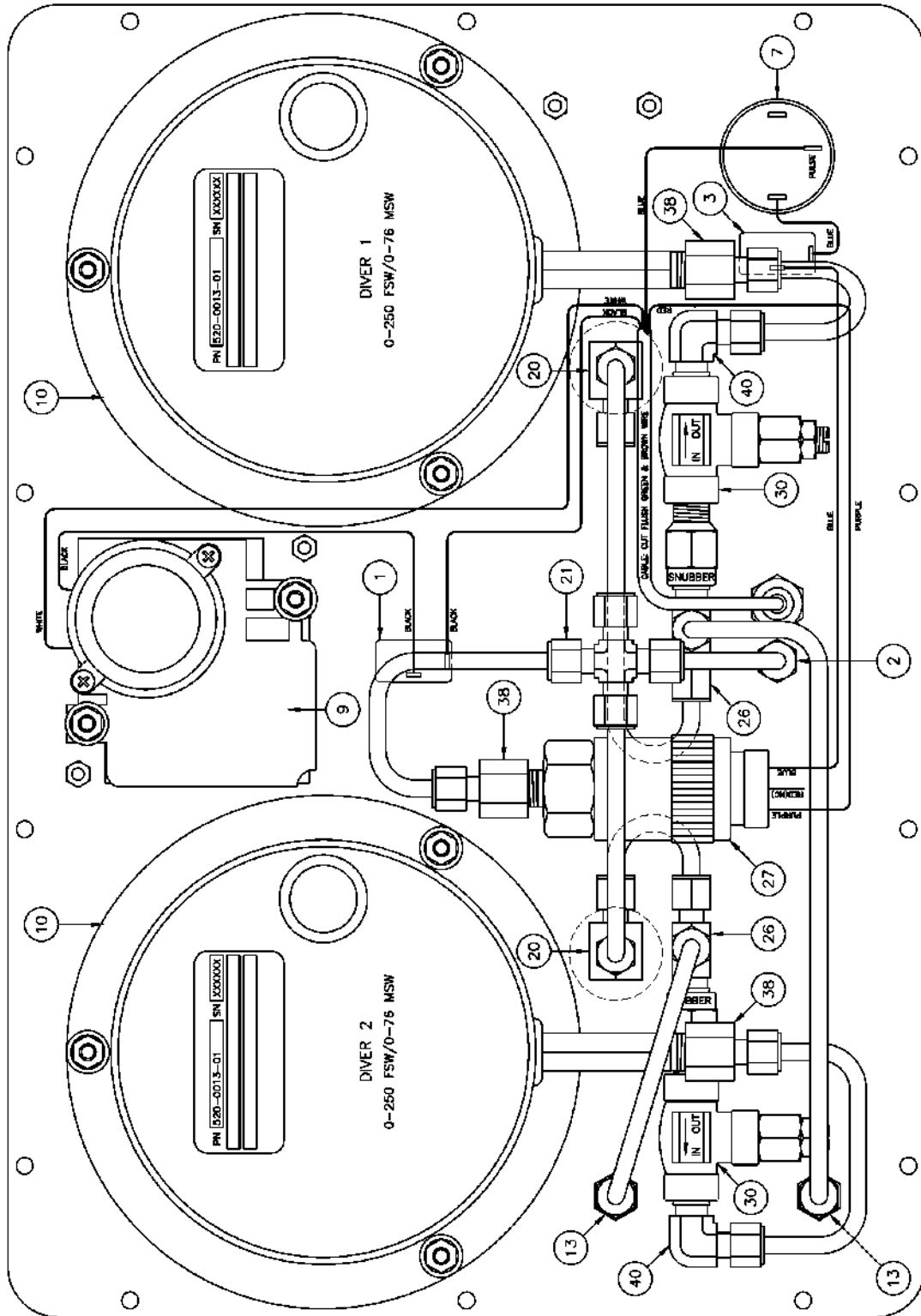

11.3 PARTS LOCATOR, 8225 SERIES AIR CONTROL PANEL (FRONT VIEW)

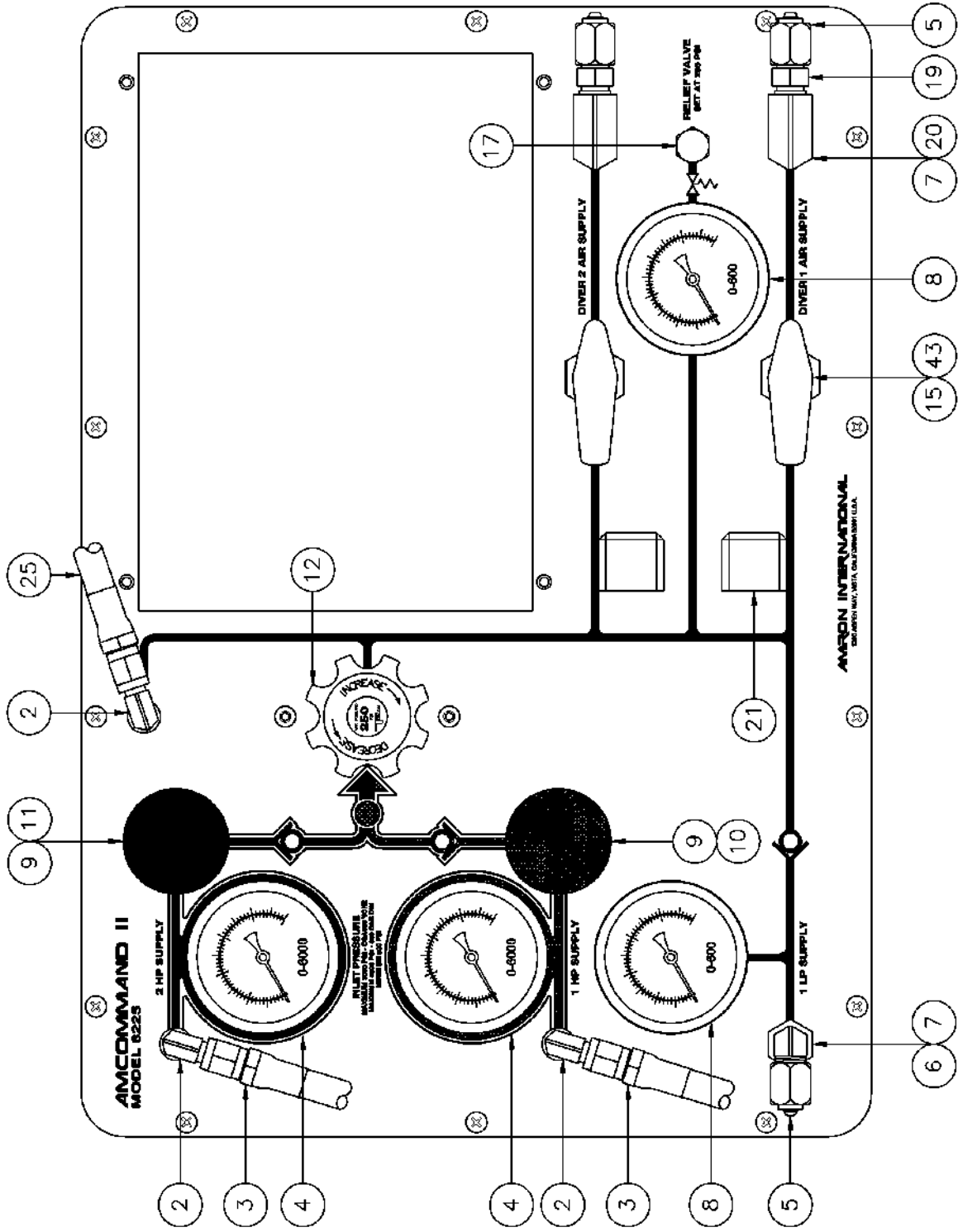

11.4 PARTS LOCATOR, 8225 SERIES AIR CONTROL PANEL (REAR VIEW)

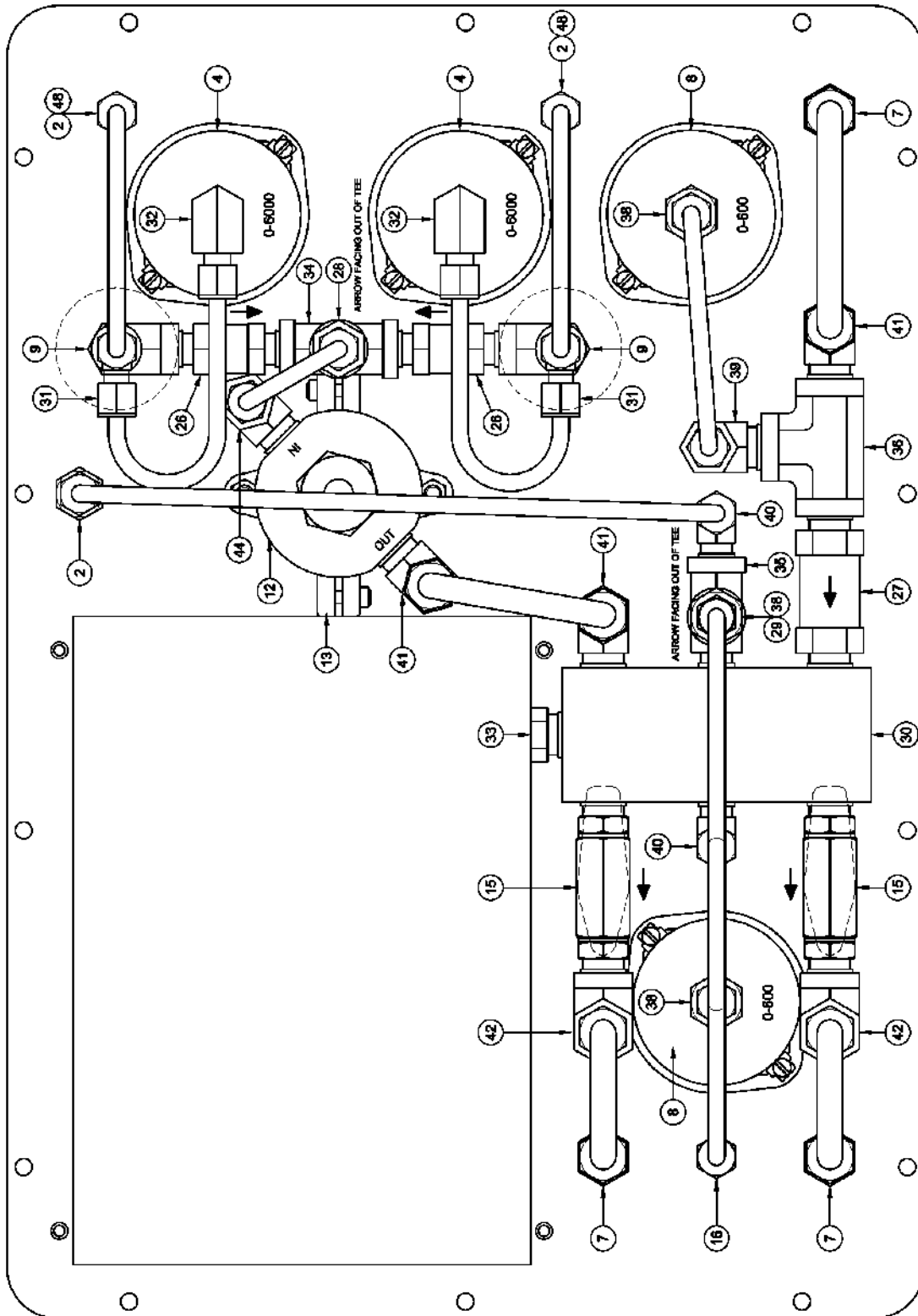

11.5 PARTS LOCATOR, MODEL 26-1512-26-277 (REGULATOR)

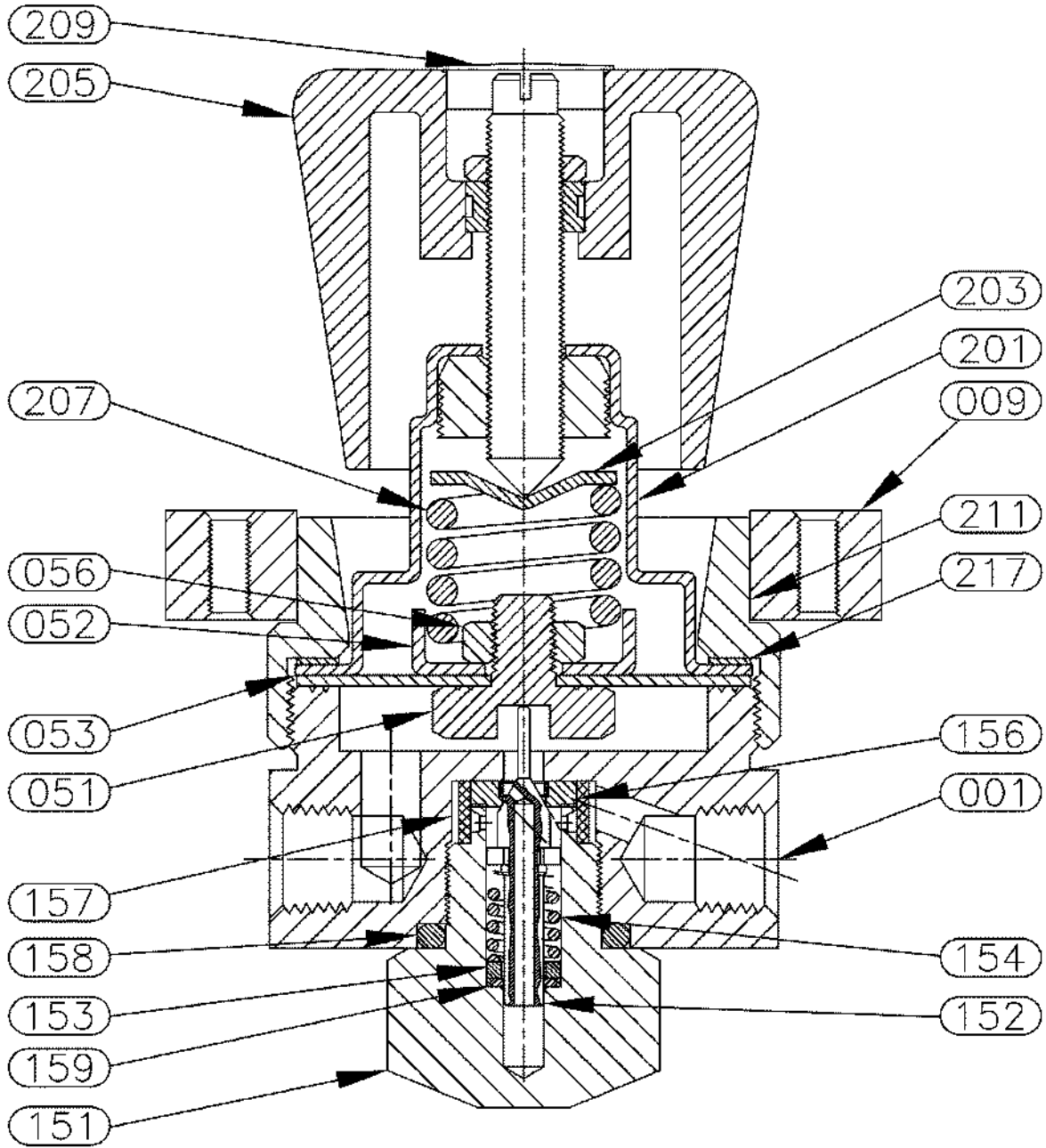

12 PARTS LISTS

The parts lists include both mechanical and electrical parts. The following information will be useful in interpreting data which is not self-explanatory.

REVISIONS

The parts lists in this manual are for the current model of diver communicator as of the printing date.

To Order Replacement Parts Contact:

Amron International, Inc.
 1380 Aspen Way, Vista, California, 92081 U.S.A.
 Telephone: (760) 208-6500 Fax: (760) 599-3857
 Email: sales@amronintl.com
 Web: www.amronintl.com

When ordering replacement parts, you should give as much information as possible to enable us to supply the correct part. This information should include the part number, description, reference designator, value, radio model number, and serial number. Failure to provide sufficient information may hinder our ability to fill your parts orders promptly and correctly.

12.1 AMCOMMAND II AIR CONTROL SYSTEM WITH COMMUNICATOR, MODEL 8225-01

Reference	Part No.	Description
N/S	8225-200	Pneumo Panel Assembly
N/S	8225-300	Case, Air Control & Pneumo System
N/S	8225-400HP	A/C Panel Assembly, 8225-HP
N/S	8225-500	HP Yoke/Hose Assembly
25	HP4FS16	16IN HP Whip #4 JIC X #4 JIC
N/S	2825A-05	Communicator
N/S	570-1008-20	Amplifier Card Assembly
6	2405-28	Hand Held Microphone P-T-T

12.2 8225-200 PNEUMO PANEL ASSEMBLY

Reference	Part No.	Description
1	757-3522	Switch, Toggle DPST
2	WEBTX-B-4	Elbow, Bulkhead Union Brass
3	7580K6	Switch, Toggle SPST
4	8225-006	Cover, Front 8225 Speaker
5	8200-016	Dust Cap with Retainer
7	273-068	Alarm, Audio
8	5168	Switch, Seal Toggle Shaft
9	SA818	Speaker, 4 ohm/15 watt
10	25545-23B11-HDP	Gauge Pneumo 6", 250 FSW/76 MSW
13	GH2BZ-B-4-4	Connector, Female Bulkhead ¼
19	MA-742	Adapter, O2 x ¼ MNPT

Reference	Part No.	Description
20	4Z-V4AK-B-YEL	Valve, Pneumo Shut-off*
21	KBZ-B-4	Cross, Union 1/4" Brass
25	HP4FS16	HP Whip; #4 JIC X #4 JIC, 16in.
26	RBZ-B-4-4-4	Tee, Male Run 1/4
27	96211-BB4	Switch, Pressure 22.5-125 PSI
30	ALV-BL-10-150	Gauge Protector, Adjustable
38	GBZ-B-4-4	Connector, Female 1/4 Brass
40	CBZ-B-4-4	Elbow, Male, 1/4" x 1/4" NPT, Brass
55	8200-016	Cap, Dust with Retainer #6

12.3 8225-400HP AIR CONTROL PANEL ASSEMBLY

Reference	Part No.	Description
2	WEBTX-B-4	Elbow, Bulkhead Union Brass
3	8225-500	HP Yoke Assembly
4	711725206000	Gauge, 0-6000 PSI w/Clamp
5	8200-016	Cap, Dust with retainer #6
6	VTX-B-6	Elbow, Male 45 Degree body only
7	GH2BZ-B-6-4	Connector, Bulkhead 3/8 Tube x 1/4 FNPT
8	71172520600	Gauge, 0-600 PSI w/Clamp
9	4F-V6AK-V-SS-KRY-LH	Valve, Angle Female Pipe, S/S with Viton
10	V6-HANDLE-RED	Handle Red
11	V6-HANDLE-BLUE	Handle Blue
12	26-1512-26-277	Regulator, Pressure 5000/265
13	1129	Regulator Mounting Bracket
15	6M-B6LJ-BP	Valve, Ball 3/8" MNPT Brass*
16	FBZ-B-4-4	Connector, Male 1/4
17	8600-014	Diffuser, Vent Cap
19	MA-742	Adapter, 02 x 1/4 MNPT Brass Chrome
20	CD-B-1/4	Elbow, Street 90 Degree 1/4 Brass
21	8225-004	Yoke/DIN Securing Block
25	HP4FS16HP	HP Whip; #4 JIC X #4 JIC, 16in.
26	4M-C4L-1/3-SS	Check Valve, S/S, 1/4 MNPT 1/3 PSI*
27	6M-C6L-1-B	Check Valve, Brass, 3/8 MNPT, 1 PSI*
28	4M4Z-F4L-50-SS	Filter, 1/4 50 Micron*
29	4CPA2-150-B	Valve, Relief Adjustable*
30	8225-005	Manifold, A/C Model 8225
31	RBZ-SS-4-4-4	Tee, Male Run 1/4 S/S
32	DBZ-SS-4-4	Elbow, Female, 1/4 S/S
33	HP-B-3/8	Plug, Hex 3/8
34	MMO-SS-1/4	Tee, Female 1/4 S/S
35	MRO-B-1/4	Tee, Street (male on run) 1/4

Reference	Part No.	Description
36	MMO-B-3/8	Tee, Female 3/8 Brass
38	GBZ-B-4-4	Connector, Female 1/4 Brass
39	CBZ-B-4-6	Elbow, Male 1/4 Tube x 3/8 NPT, Brass
40	CBZ-B-4-4	Elbow, Male 1/4 x 1/4 Brass
41	CBZ-B-6-6	Elbow, Male 3/8 Brass
42	DBZ-B-6-6	Elbow, Female 3/8 Brass
43	B6-PANEL-NUT-SS	Panel Nut, #8 Air Control
44	CBZ-SS-4-6	Elbow, Male 1/4 Tube x 3/8 NPT, S/S
48	AP50C-4	Copper Seal, #4 JIC

12.4 8225-500 YOKE/HOSE ASSEMBLY

Reference	Part No.	Description
3	72HP	Hose Assembly, 72" HP (5000)
N/S	FTX-B-4-4	Male Connector, #4 JIC x 1/4 MNPT
N/S	9913-02	Yoke & Bleeder Assembly
N/S	RP75-BLUE	Hose Protector, Blue
N/S	RP75-RED	Hose Protector, Red

12.5 26-1512-26-277 PRESSURE REDUCING REGULATOR

Reference	Part No.	Description
001	2900-2610	Body, Ported
009	1129	Bracket, Mounting Assy
051	1214-2	Button, Diaphragm
052	2648	Diaphragm Stop H713-15
053	2645	Diaphragm, Buna-N .050
056	2646-1	Nut, 5/16-18 HEXH313-15
151	5180-1	Cap, Back Brass
152	5840-6	Stem, Valve
153	1186-6	Retainer, Valve Spring
154	5378	Spring, 0.34, 0.63, 70, 302 SST
156	6850	Seat, CTFE (.207 OR.)
157	6633	Filter, .62 OD .51 ID .29 THK
158	5200-002107	O-Ring, Buna-N
159	5200-000087	O-Ring, Buna-N
201	1619	Bonnet, Assembly
203	1218	Button, Spring
205	1150	Hand Knob, Assembly
207	JT102275	Spring, 1.00, 1.00, 2150
209	8515-250	Hole Plug, Logo Black/White
211	1212-1	Bonnet, Ring (43295)

12.6 FRONT PANEL PARTS IDENTIFIER FOR 2825A-05 COMMUNICATOR

Reference	Part No.	Description
2	PBSWITCH	Switch, Push Button SPST (mom)
3	7580K6	Switch, Toggle SPST
4	P16NP-10K	Potentiometer, 10K ohms with knobs
5	1498-102	Jack, Banana Red
6	1498-103	Jack, Banana Black
7	1498-107	Jack, Banana Yellow
8	5168	Seal, Half Boot, Toggle
9	105-0602-001	Jack, Tip Red
10	105-0603-001	Jack, Tip Black
11	ME161-2003	RCA Phono Jack
14	14002B	Binding Post, Black
15	14002R	Binding Post, Red
16	LEDHOLDER-BLK.25	Mounting Clip, for 5mm LED
17	LT2462-24-D51	LED, BI-Color Red/Green
19	492	Handle
20	P-2392	AC Power Cord
25	24XX-MIC	Panel Microphone Assembly
29	LEDGREEN	LED Green, AC Power
30	MS-3102A-14S-6S	MS Connector, Bulkhead 6 Pin Female

12.7 RECOMMENDED SPARE PARTS

Reference	Part No.	Description
N/S	KIT-C4-1/3-V	Repair Kit, for P/N 4M-C4L-1/3-SS
N/S	802065-4	Repair Kit for Parker P/N B6LJ-B Series Ball Valve
N/S	822188-SS	Repair Kit, for P/N 4FV6AKVSS-B2500-KRY, 4FV6AKVSS-R2500-KRY, 4FV6AKVSS-W2500-KRY
N/S	KIT-F4-50-V	Repair Kit, for P/N 4M4Z-F4L-50-SS
N/S	KIT-C6-1-V	Repair Kit, for P/N 6M-C6L-1-B
N/S	KIT-V4K-B	Repair Kit for P/N 4Z-V4AK-B-YEL
3	72HP	Hose Assembly, 72" HP (5000)
14	14002B	Binding Post, Black
28	14002R	Binding Post, Red
5	1498-102	Jack, Banana Red
6	1498-103	Jack, Banana Black
7	1498-107	Jack, Banana Yellow
8	5168	Switch, Seal Toggle Shaft
3	7580K6	Switch, Toggle SPST
2	PBSWITCH	Switch, Push Button SPST (mom)
N/S	2890-05	Battery, 12 Volt, 7 Ah
N/S	14001B	Plug, Dual Banana Black

Reference	Part No.	Description
N/S	14001Y	Plug, Dual Banana Yellow
N/S	14001R	Plug, Dual Banana Red
N/S	2832-202-01	Amplifier Card Assembly
N/S	2405-28	Hand Held Microphone P-T-T
157	6633	Filter, .62 OD .51 ID .29 THK

12.8 REGULATOR REPAIR KIT FOR 26-1512-26-277

Reference	Part No.	Description
N/S	389-6907	Regulator Repair Kit for 26-1512-26-277
053	2645	Diaphragm, Buna-N .050
152	5840-6	Stem, Valve
153	1186-6	Retainer, Valve Spring
154	5378	Spring, 0.34,0.63,70,302 SST
156	6850	Seat, CTFE (.207 OR.)
158	5200-002107	O-Ring, Buna-N
159	5200-000087	O-Ring, Buna-N

12.9 REGULATOR SOFT GOODS KIT FOR 26-1512-26-277

Reference	Part No.	Description
N/S	389-6906	Regulator Soft Goods Kit for 26-1512-26-277
053	2645	Diaphragm, Buna-N .050
156	6850	Seat, CTFE (.207 OR.)
158	5200-002107	O-Ring, Buna-N
159	5200-000087	O-Ring, Buna-N

14 LIMITED WARRANTY AND SERVICE POLICY

Amron International, Inc.

LIMITED WARRANTY & SERVICE POLICY

LIMITED WARRANTY

AMRON INTERNATIONAL, INC., (Amron) warrants that its manufactured products are free from defects in material and workmanship under normal use and service for a period of one year from date of shipment as described in Amron's literature covering this product. Oxygen Treatment Hoods and accessories are excluded and limited to 90 days. Amron's obligation under this warranty is limited to the repair or replacement, at Amron's option, of defective material. This warranty shall not cover defects which are the result of misuse, negligence, accident, repair or alterations.

SERVICE POLICY

For technical assistance or to request a repair, please complete one of the following:

- *Amron Communicator Repair* : <https://www.amronintl.com/communicator-repair-form>
- *Repair Request* (all other products): <https://www.amronintl.com/repair-form>
- Call (760) 208-6500, Monday – Friday, 8 a.m. to 5 p.m. PST.

Both MODEL NO. and SERIAL NO. are required fields to be entered on the *Amron Communicator Repair Request* form and can be found on the products identification label as shown below.

“Sample” Product Identification Label

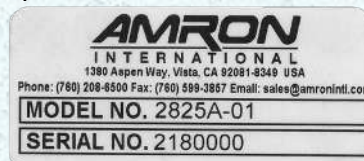

Do not return any product without obtaining a RMR (Return Materials Request). Detailed return instructions will be provided at the time of request.

1380 Aspen Way, Vista California 92081-8349 U.S.A
Phone: (760) 208-6500 Fax (760) 599-3857
Email: sales@amronintl.com Web: www.amronintl.com