

STANLEY®

CT10 HYDRAULIC CRIMPING TOOL



USER'S MANUAL Safety, Operation and Maintenance



© 2014 STANLEY Black & Decker, Inc.
New Britain, CT 06053
U.S.A.
58545 4/2019 Ver. 14

TABLE OF CONTENTS

SAFETY SYMBOLS.....	4
SAFETY PRECAUTIONS	5
TOOL STICKERS & TAGS	6
HOSE TYPES	7
HOSE RECOMMENDATIONS.....	8
HTMA / EHTMA REQUIREMENTS	9
OPERATION	10
TOOL PROTECTION & CARE.....	14
TROUBLESHOOTING	15
SPECIFICATIONS	16
CT10016N PARTS ILLUSTRATION	17
CT10016N PARTS LIST	18
CT10056DH PARTS ILLUSTRATION.....	19
CT10056DH PARTS LIST.....	20
CT10056N PARTS ILLUSTRATION	21
CT10056N PARTS LIST	22
CT10066AN PARTS ILLUSTRATION.....	23
CT10066AN PARTS LIST.....	24

IMPORTANT

To fill out a product warranty validation form, and for information on your warranty, visit www.stanleyinfrastructure.com and select the Company tab > Warranty.

Note: The warranty validation record must be submitted to validate the warranty.

SERVICING: This manual contains safety, operation and routine maintenance instructions. STANLEY Infrastructure recommends that servicing of hydraulic tools, other than routine maintenance, must be performed by an authorized and certified dealer. Please read the following warning.

WARNING

SERIOUS INJURY OR DEATH COULD RESULT FROM THE IMPROPER REPAIR OR SERVICE OF THIS TOOL.

REPAIRS AND / OR SERVICE TO THIS TOOL MUST ONLY BE DONE BY AN AUTHORIZED AND CERTIFIED DEALER.

For the nearest certified dealer, call STANLEY Infrastructure at (503) 659-5660 and ask for a Customer Service Representative.

SAFETY PRECAUTIONS

Tool operators and maintenance personnel must always comply with the safety precautions given in this manual and on the stickers and tags attached to the tool and hose.

These safety precautions are given for your safety. Review them carefully before operating the tool and before performing general maintenance or repairs.

Supervising personnel should develop additional precautions relating to the specific work area and local safety regulations. Place the added precautions in the space provided on page 4.



The CT10 Hydraulic Crimping Tool will provide safe and dependable service if operated in accordance with the instructions given in this manual. Read and understand this manual and any stickers and tags attached to the tool and hose before operation. Failure to do so could result in personal injury or equipment damage.



- The operator must start in a work area without bystanders. Flying debris can cause serious injury.
- Do not operate the tool unless thoroughly trained or under the supervision of an instructor. Establish a training program for all operators to ensure safe operation.
- Always wear safety equipment such as goggles, ear and head protection, and safety shoes at all times when operating the tool. Use gloves and aprons when necessary.
- The operator must be familiar with all prohibited work areas such as excessive slopes and dangerous terrain conditions.
- Do not inspect, clean or replace any parts if the hydraulic power source is connected. Do not inspect or clean the tool while the hydraulic power source is connected. Accidental engagement of the tool can cause serious injury.
- Always connect hoses to the tool hose couplers before energizing the hydraulic power source. Be sure all hose connections are tight and are in good condition.
- Do not operate the tool at oil temperatures above 140°F/60°C. Operation at higher temperatures can cause higher than normal temperatures at the tool which can result in operator discomfort.
- Do not operate a damaged, improperly adjusted or incompletely assembled tool. Do not carry tool by the hoses.
- Never wear loose clothing that can become entangled in the working parts of the tool.
- Keep all parts of your body away from the tool and maintain proper footing and balance at all times.
- Do not rely exclusively upon the safety devices built into the tool.
- Always be well rested and mentally alert before operating the tool.
- Do not allow other persons to be near the tool when in operation. Keep bystanders and animals out of the work area.
- Keep the handles dry, clean and free of oil.
- When using tools near energized transmission lines, be sure to use only hoses labeled and certified non-conductive.
- Turn off the power unit or move the hydraulic control valve to neutral before setting the tool down.
- Know the location of buried or covered electrical services before starting work.
- To avoid personal injury or equipment damage, all tool repair, maintenance and service must only be performed by authorized and properly trained personnel.

TOOL STICKERS & TAGS

Please refer to the Parts List Illustration for location of stickers.

<p>STANLEY Stanley Hydraulic Tools 3810 SE Naef Road Milwaukie, OR 97267</p> <p>Model No. CT10</p> <p>11-34 (p/n 0) gpm 138 bar (2000 psi)</p> <p>OC/CC For use on open center and closed center hydraulic systems. Use open center tool on open center systems. Use closed center tool on closed center systems. Set tool for proper system before use.</p> <p>CAUTION DO NOT OPERATE WITHOUT DIES</p>	<p>WARNING</p>	
		<p>Read owners manual and make sure that you have been properly trained in the correct procedures required for work. On or around electric lines. Failure to use hydraulic hose labeled and certified as non-conductive when using hydraulic tools on or near electric lines may result in death or serious injury.</p>
		<p>Do not exceed specified flow or pressure. Correctly connect hoses to tool "IN" and "OUT". Improper handling, use or maintenance can result in a leak or burst. Contact at a leak or burst can cause oil injection to the body. Failure to observe the precautions can result in serious personal injury.</p>
		<p>Stay clear of dies and tool heads. Failure to observe the precautions can result in serious personal injury.</p>

76652
CT10 Sticker

NOTE

THE INFORMATION LISTED ON THE STICKERS SHOWN, MUST BE LEGIBLE AT ALL TIMES.

REPLACE DECALS IF THEY BECOME WORN OR DAMAGED. REPLACEMENTS ARE AVAILABLE FROM YOUR LOCAL STANLEY DISTRIBUTOR.

The safety tag (p/n 15875) at right is attached to the tool when shipped from the factory. Read and understand the safety instructions listed on this tag before removal. We suggest you retain this tag and attach it to the tool when not in use.

DANGER

1. FAILURE TO USE HYDRAULIC HOSE **Labeled and Certified as Non-Conductive** when using hydraulic tools on or near electrical lines may result in death or serious injury.

BEFORE USING HOSE **Labeled and Certified as Non-Conductive** on or near electrical lines be sure the hose is **Maintained as Non-Conductive**. The hose should be regularly tested for electric current leakage in accordance with your safety department instructions.

2. A HYDRAULIC LEAK OR BURST MAY CAUSE OIL INJECTION INTO THE BODY OR CAUSE OTHER SEVERE PERSONAL INJURY.

A **DO NOT EXCEED SPECIFIED FLOW AND PRESSURE FOR THIS TOOL. EXCESS FLOW OR PRESSURE MAY CAUSE A LEAK OR BURST.**

B **DO NOT EXCEED RATED WORKING PRESSURE OF HYDRAULIC HOSE USED WITH THIS TOOL. EXCESS PRESSURE MAY CAUSE A LEAK OR BURST.**

C **CHECK TOOL HOSE COUPLERS AND CONNECTORS DAILY FOR LEAKS. DO NOT FEEL FOR LEAKS WITH YOUR HANDS. CONTACT WITH A LEAK MAY RESULT IN SEVERE PERSONAL INJURY.**

IMPORTANT

READ OPERATION MANUAL AND SAFETY INSTRUCTIONS FOR THIS TOOL BEFORE USING IT.

USE ONLY PARTS AND REPAIR PROCEDURES APPROVED BY STANLEY AND DESCRIBED IN THE OPERATION MANUAL.

TAG TO BE REMOVED ONLY BY TOOL OPERATOR.

SEE OTHER SIDE

DANGER

D **DO NOT LIFT OR CARRY TOOL BY THE HOSES. DO NOT ABUSE HOSE. DO NOT USE KINKED, TORN OR DAMAGED HOSE.**

3. **MAKE SURE HYDRAULIC HOSES ARE PROPERLY CONNECTED TO THE TOOL BEFORE PRESSURING SYSTEM. SYSTEM PRESSURE HOSE MUST ALWAYS BE CONNECTED TO TOOL "IN" PORT. SYSTEM RETURN HOSE MUST ALWAYS BE CONNECTED TO TOOL "OUT" PORT. REVERSING CONNECTIONS MAY CAUSE REVERSE TOOL OPERATION WHICH CAN RESULT IN SEVERE PERSONAL INJURY.**

4. **DO NOT CONNECT OPEN-CENTER TOOLS TO CLOSED-CENTER HYDRAULIC SYSTEMS. THIS MAY RESULT IN LOSS OF OTHER HYDRAULIC FUNCTIONS POWERED BY THE SAME SYSTEM AND/OR SEVERE PERSONAL INJURY.**

5. **BYSTANDERS MAY BE INJURED IN YOUR WORK AREA. KEEP BYSTANDERS CLEAR OF YOUR WORK AREA.**

6. **WEAR HEARING, EYE, FOOT, HAND AND HEAD PROTECTION.**

7. **TO AVOID PERSONAL INJURY OR EQUIPMENT DAMAGE, ALL TOOL REPAIR MAINTENANCE AND SERVICE MUST ONLY BE PERFORMED BY AUTHORIZED AND PROPERLY TRAINED PERSONNEL.**

IMPORTANT

READ OPERATION MANUAL AND SAFETY INSTRUCTIONS FOR THIS TOOL BEFORE USING IT.

USE ONLY PARTS AND REPAIR PROCEDURES APPROVED BY STANLEY AND DESCRIBED IN THE OPERATION MANUAL.

TAG TO BE REMOVED ONLY BY TOOL OPERATOR.

SEE OTHER SIDE

SAFETY TAG P/N 15875 (Shown smaller than actual size)

HOSE TYPES

The rated working pressure of the hydraulic hose must be equal to or higher than the relief valve setting on the hydraulic system. There are three types of hydraulic hose that meet this requirement and are authorized for use with STANLEY hydraulic tools. They are:

Certified non-conductive — constructed of thermoplastic or synthetic rubber inner tube, synthetic fiber braid reinforcement, and weather resistant thermoplastic or synthetic rubber cover. *Hose labeled **certified non-conductive** is the only hose authorized for use near electrical conductors.*

Wire-braided (conductive) — constructed of synthetic rubber inner tube, single or double wire braid reinforcement, and weather resistant synthetic rubber cover. *This hose is **conductive** and must never be used near electrical conductors.*

Fabric-braided (not certified or labeled non-conductive) — constructed of thermoplastic or synthetic rubber inner tube, synthetic fiber braid reinforcement, and weather resistant thermoplastic or synthetic rubber cover. *This hose is **not certified non-conductive** and must never be used near electrical conductors.*

HOSE SAFETY TAGS

To help ensure your safety, the following DANGER tags are attached to all hose purchased from STANLEY. DO NOT REMOVE THESE TAGS.

If the information on a tag is illegible because of wear or damage, replace the tag immediately. A new tag may be obtained from your STANLEY Distributor.

THE TAG SHOWN BELOW IS ATTACHED TO “CERTIFIED NON-CONDUCTIVE” HOSE

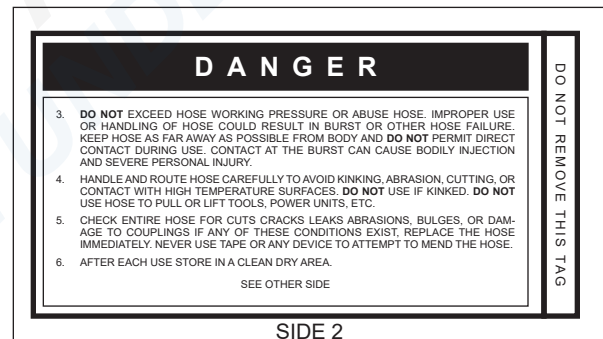
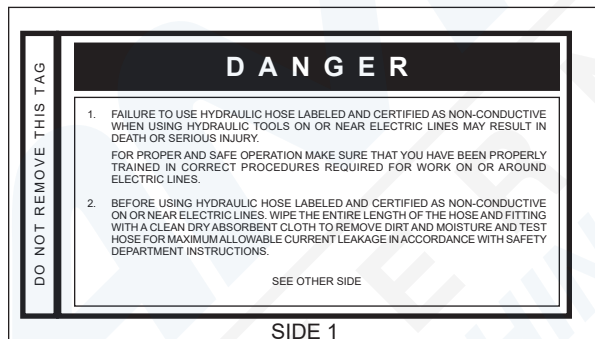

(Shown smaller than actual size)

THE TAG SHOWN BELOW IS ATTACHED TO “CONDUCTIVE” HOSE.

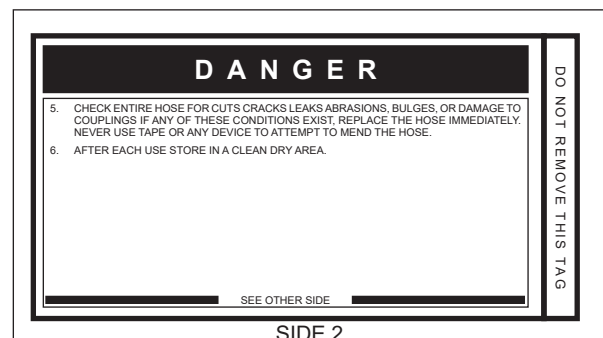
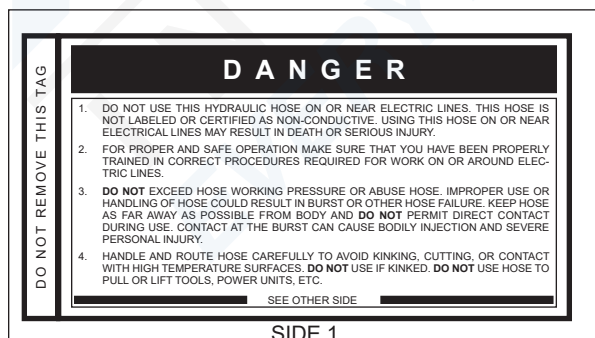

(Shown smaller than actual size)

HOSE RECOMMENDATIONS

Tool to Hydraulic Circuit Hose Recommendations

The chart to the right shows recommended minimum hose diameters for various hose lengths based on gallons per minute (GPM)/liters per minute (LPM). These recommendations are intended to keep return line pressure (back pressure) to a minimum acceptable level to ensure maximum tool performance.

This chart is intended to be used for hydraulic tool applications only based on STANLEY tool operating requirements and should not be used for any other applications.

All hydraulic hose must have at least a rated minimum working pressure equal to the maximum hydraulic system relief valve setting.

All hydraulic hose must meet or exceed specifications as set forth by SAE J517.

Oil Flow		Hose Lengths		Inside Diameter		USE (Press/Return)	Min. Working Pressure	
GPM	LPM	FEET	METERS	INCH	MM		PSI	BAR
Certified Non-Conductive Hose - Fiber Braid - for Utility Bucket Trucks								
4-9	15-34	up to 10	up to 3	3/8	10	Both	2250	155
Conductive Hose - Wire Braid or Fiber Braid - DO NOT USE NEAR ELECTRICAL CONDUCTORS								
4-6	15-23	up to 25	up to 7.5	3/8	10	Both	2500	175
4-6	15-23	26-100	7.5-30	1/2	13	Both	2500	175
5-10.5	19-40	up to 50	up to 15	1/2	13	Both	2500	175
5-10.5	19-40	51-100	15-30	5/8	16	Both	2500	175
5-10.5	19-40	100-300	30-90	5/8	16	Pressure	2500	175
10-13	38-49	up to 50	up to 15	3/4	19	Return	2500	175
10-13	38-49	51-100	15-30	5/8	16	Both	2500	175
10-13	38-49	100-200	30-60	3/4	19	Pressure	2500	175
13-16	49-60	up to 25	up to 8	1	25.4	Return	2500	175
13-16	49-60	26-100	8-30	5/8	16	Pressure	2500	175
				3/4	19	Return	2500	175
				3/4	19	Pressure	2500	175
				1	25.4	Return	2500	175

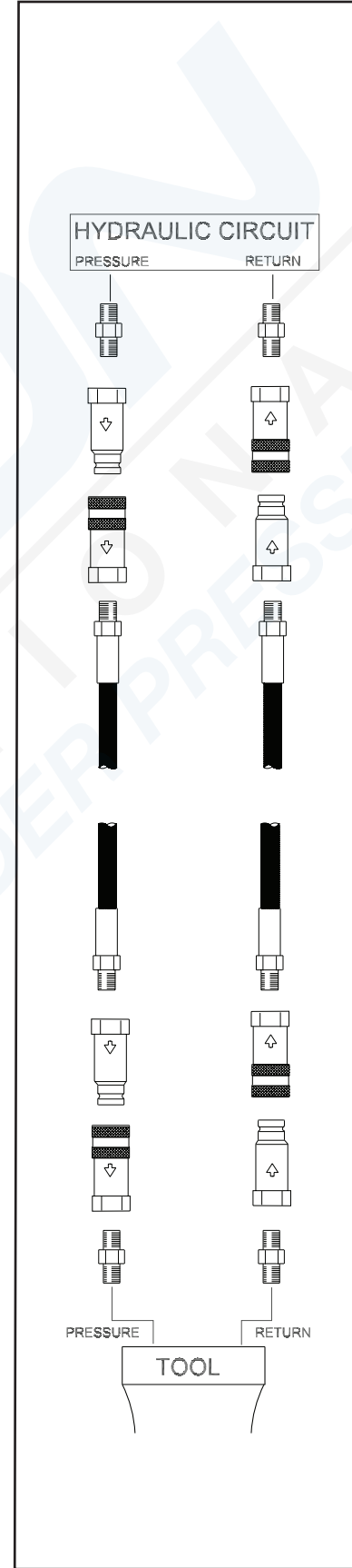

Figure 1. Typical Hose Connections





HTMA / EHTMA REQUIREMENTS

HTMA / EHTMA REQUIREMENTS

TOOL TYPE

HTMA HYDRAULIC SYSTEM REQUIREMENTS	TYPE I	TYPE II	TYPE RR	TYPE III
Flow range	4-6 GPM (15-23 LPM)	7-9 GPM (26-34 LPM)	9-10.5 GPM (34-40 LPM)	11-13 GPM (42-49 LPM)
Nominal operating pressure (At the power supply outlet)	1500 psi (103 bar)	1500 psi (103 bar)	1500 psi (103 bar)	1500 psi (103 bar)
System relief valve setting (At the power supply outlet)	2100-2250 psi (145-155 bar)	2100-2250 psi (145-155 bar)	2200-2300 psi (152-159 bar)	2100-2250 psi (145-155 bar)
Maximum back pressure (At tool end of the return hose)	250 psi (17 bar)	250 psi (17 bar)	250 psi (17 bar)	250 psi (17 bar)
Measured at a max fluid viscosity of: (At minimum operating temperature)	400 ssu* (82 centistokes)	400 ssu* (82 centistokes)	400 ssu* (82 centistokes)	400 ssu* (82 centistokes)
Temperature: Sufficient heat rejection capacity to limit maximum fluid temperature to: (At maximum expected ambient temperature)	140° F (60° C)	140° F (60° C)	140° F (60° C)	140° F (60° C)
Minimum cooling capacity at a temperature difference of between ambient and fluid temps	3 hp (2.24 kW) 40° F (22° C)	5 hp (3.73 kW) 40° F (22° C)	6 hp (5.22 kW) 40° F (22° C)	7 hp (4.47 kW) 40° F (22° C)
Note: Do not operate the tool at oil temperatures above 140° F (60° C). Operation at higher temperatures can cause operator discomfort at the tool.				
Filter minimum full-flow filtration Sized for flow of at least: (For cold temp startup and maximum dirt-holding capacity)	25 microns 30 GPM (114 LPM)	25 microns 30 GPM (114 LPM)	25 microns 30 GPM (114 LPM)	25 microns 30 GPM (114 LPM)
Hydraulic fluid, petroleum based (premium grade, anti- wear, non-conductive) Viscosity (at minimum and maximum operating temps)	100-400 ssu (20-82 centistokes)	100-400 ssu (20-82 centistokes)	100-400 ssu (20-82 centistokes)	100-400 ssu (20-82 centistokes)
Note: When choosing hydraulic fluid, the expected oil temperature extremes that will be experienced in service determine the most suitable temperature viscosity characteristics. Hydraulic fluids with a viscosity index over 140 will meet the requirements over a wide range of operating temperatures.				
*SSU = Saybolt Seconds Universal				

CLASSIFICATION

EHTMA HYDRAULIC SYSTEM REQUIREMENTS					
Flow range	3.5-4.3 GPM (13.5-16.5 LPM)	4.7-5.8 GPM (18-22 LPM)	7.1-8.7 GPM (27-33 LPM)	9.5-11.6 GPM (36-44 LPM)	11.8-14.5 GPM (45-55 LPM)
Nominal operating pressure (At the power supply outlet)	1870 psi (129 bar)	1500 psi (103 bar)	1500 psi (103 bar)	1500 psi (103 bar)	1500 psi (103 bar)
System relief valve setting (At the power supply outlet)	2495 psi (172 bar)	2000 psi (138 bar)	2000 psi (138 bar)	2000 psi (138 bar)	2000 psi (138 bar)

Note: These are general hydraulic system requirements. See tool specification page for tool specific requirements.

OPERATION

PREPARATION

Careful inspection of the tool and hydraulic system before startup is important for safe, reliable operation of the tool.

The following items should be checked daily at the start and the end of each work shift.

1. Make sure the proper dies are securely in place. Operating the tool without dies can deform the crimping heads. Refer to “Die Installation” on page 10.
2. Connect hoses. Wipe all hose couplers with a clean, lint-free cloth before making connections. Dirty couplers can contaminate the hydraulic lines and prevent a good seal at the connection.
3. Check all fasteners for tightness.
4. Check the equipment for oil leaks. If leaks are observed, do not use the tool; have the equipment serviced before use.
5. Check the tool and hydraulic system for proper operation and performance.
6. If the equipment does not appear to operate properly, have it serviced before use.
7. Periodically verify the crimping force of the tool. Refer to “Die Load Verification” on page 12.

SETUP AND TEST

Never operate the tool without dies. Operating without dies can deform the crimping head (retainer die yoke or C-frame).

If this happens, the dies cannot be installed and the crimping head must be replaced.

Never install the dies while the hydraulic hoses are connected to the tool.

Verify the crimping force before operating the tool.

OPEN CENTER/CLOSED CENTER SETUP

The CT10 Hydraulic Crimping Tool can be configured for either open-center (OC) or closed-center (CC) operation.

The current setting is easily determined by looking at the gap between the adapter and the cylinder:

TO CHANGE THE CURRENT SETTING:

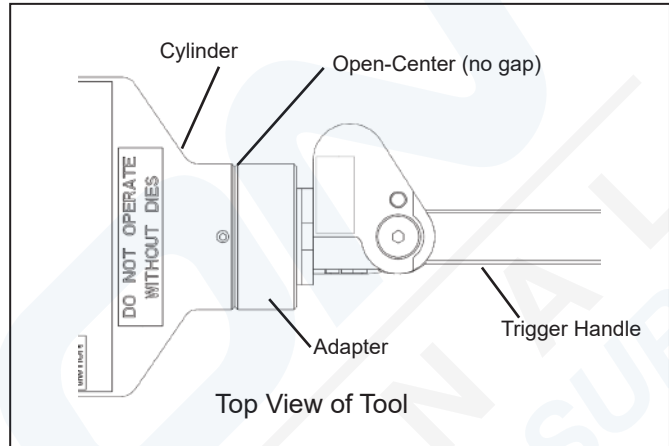

1. Remove the hydraulic hose coupling from the return port on the tool, if one is installed. When making the change from CC to OC, hydraulic fluid may be trapped in the tool, preventing complete movement of the adapter. Remove the return coupling to allow the hydraulic fluid to escape.
2. Loosen the 2 setscrews on the cylinder.
3. Turn the adapter until it stops:
 - Counter clockwise (CCW) to change to closed center (creates gap)
 - Clockwise (CW) to change to open center (closes gap)
4. Tighten the two setscrews.

DIE INSTALLATION

One die is installed in the crimping head (Retainer Die Yoke or C-frame) and the other die is installed onto the ram or die piston assembly, depending on the model. See figure to identify the style of crimping head you have. Refer to the parts illustrations for more detailed reference.

OPERATION

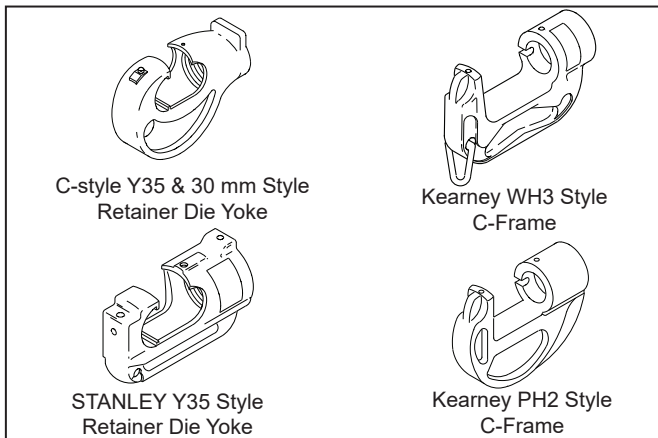

To install dies, follow the instructions below for your model of crimping head.

1. If the hydraulic hoses are connected:
 - Turn the hydraulic system control valve OFF.
 - Disconnect first the hydraulic input (supply) hose, then the output (return) hose.
2. Clean the surfaces of the die holder to remove any dirt or grease.
3. Select the dies for the task:
 - If the die load *has not* been verified, select blank dies and verify die load.
 - If the die load *has* been verified, select a set of dies to match the sleeve or connector to be crimped.

TO INSTALL DIES ON STANLEY OR C-STYLE CRIMPING HEADS - Y35 STYLE

Install the die to the Retainer Die Yoke:

1. Insert and center the die until it clicks into place.

Install the die to the Die Piston Assembly or Ram:

1. Press the die release pin at the side of the die piston assembly or ram.
2. Insert and center the die.
3. Release the pin to lock the die in place.

TO INSTALL DIES ON STANLEY OR KEARNEY CRIMPING HEADS - PH2 STYLE

Install the die to the C-Frame:

1. Loosen the cap screw at the side of the C-frame.
2. Press the stub on the die into the socket.
3. Tighten the cap screw to retain the die.

Install the die to the push rod.

1. Loosen the cap screw at the side of the push rod.
2. Press the stub on the die into the push rod socket.
3. Tighten the cap screw to retain the die.

TO INSTALL DIES ON KEARNEY CRIMPING HEAD -WH3 STYLE:

Install the die to the C-Frame:

1. Loosen the cap screw at the side of the C-frame.
2. Press the stub on the die into the socket.
3. Tighten the cap screw to retain the die .

Install the die to the push rod.

1. Loosen the cap screw at the side of the push rod.
2. Press the stub on the die into the push rod socket.
3. Tighten the cap screw to retain the die.

Make sure the hydraulic system control valve is in the OFF position when coupling or uncoupling the hoses. Failure to do so may result in damage to the quick couplers and cause overheating of the hydraulic system.

Before installing the hoses, wipe the fittings and the entire length of the hoses with a clean, dry lint-free cloth to remove any dirt or moisture. Dirty connections can contaminate the hydraulic fluid, causing rapid wear and early failure of internal parts.

Check the flow indicators (arrows) stamped on the couplers to ensure oil flows in the proper direction. The female coupler on the tool is the inlet coupler.

Connect the output (return) hose first and disconnect it last to minimize trapped pressure within the tool.

1. Connect the output hose to the OUT or "T" port on the tool.

OPERATION

2. Connect the input hose to the IN or “P” port.
3. Be sure all hose connections are tight.

DIE LOAD VERIFICATION

With blank (test) dies installed, use a die load tester to verify the crimping force in the tool before operating a new crimping tool, placing the tool in service or repairing the tool.

1. Make sure blank (test) dies are installed in the die holder. If not, follow “Die Installation” on page 10.
2. Connect the tool to an appropriate hydraulic power source. Follow the Hydraulic Hose Connection safety guidelines and instructions in this section. If possible, use the hydraulic power source you plan to use for crimping.
3. Place the die load tester between the blank (test) dies.
4. Actuate the tool and read the value shown on the load tester indicator. The force should be 10–12 tons (9072–10,886 kg), depending on the pressure from the hydraulic power source.
5. If the indicated value is low and the system pressure relief valve setting is greater than 1650 psi (114 bar), adjust the relief valve on the CT to get the correct die load. If the indicated value is high, adjust the relief valve on the CT to get the correct die load.
6. When the value is within the acceptable range, turn the hydraulic system control valve OFF and disconnect the hoses from the tool.
7. Follow “Die Installation” on page 10 to remove the blank dies and install the proper crimping dies.

OC/CC SETTING

Check the open-center/closed-center (OC/CC) setting on the tool. The current setting is easily determined by looking at the gap between the adapter and the cylinder.

- Open center - no gap
- Closed center -approximately ¼-inch (6.4-mm) gap

If the setting is not correct for your hydraulic system, follow the instructions in this section, OC/CC Adjustment, to make the change.

DIE CHECK

Make sure the dies installed in the tool match the sleeve or connector to be crimped. If not, follow “Die Installation” on page 10.

CHECK POWER SOURCE

Using a calibrated flow meter and pressure gauge, check the hydraulic power source at the tool’s input port. Make sure the system maintains an operating flow in the range of 3-9 GPM/11-34 LPM within a pressure range of 1650-2000 psi /114-140 bar.

The hydraulic fluid temperature should be at least 80°F/27°C for this test.

CONNECT HOSES

1. Wipe all hose couplers with a clean, lint-free cloth before making connections.
2. Connect hoses from the hydraulic power source to the tool fittings or quick disconnects. It is good practice to connect the return hose first and disconnect it last to minimize or eliminate trapped pressure within the wrench.
3. Observe the flow indicators stamped on the main body assembly and the hose couplers to ensure that the flow is in the proper directions. The female couple on the tools “IN” port is the inlet (pressure) coupler.

Note: If the uncoupled hoses are left in the sun, pressure increase within the hoses can make them difficult to connect. Whenever possible, connect the free ends of the hoses together.

OPERATION

Observe all safety precautions when operating the tool. Read safety and hydraulic system requirements, before operating the tool for the first time.

CONDUCTOR PREPARATION

1. If the conductor is insulated, remove the insulation from the end of the conductor. Use an insulation stripping tool. If a stripping tool is not available, carefully shave the insulation from the cable. Be sure not to nick or cut the strands of the conductor.

OPERATION

2. Remove any oxide or foreign matter from the exposed conductor. A bright, shiny surface is required for a good connection. Do not wire-brush tin-plated copper conductors or tinned connectors.

STARTUP

1. Move the hydraulic system control valve to the ON position.
2. Remove any trapped air from the tool by squeezing the trigger 4 or 5 times to advance and retract the piston to nearly full stroke.
3. Position the tool to make the crimp.

IMPORTANT

Failure to center the connector between the dies will damage the dies and/or die holders.

4. Hook the stationary (retainer die yoke or C-frame) die on the connector being crimped to ensure the connector is centered between the dies.
5. Squeeze the trigger to advance the piston and crimp the connector.
6. Release the trigger to retract the piston.
7. Slide the tool into position for the next crimp. Some sleeves and connectors have special crimping requirements. Refer to the fitting manufacturer's requirements.
8. Remove the tool by lifting it free of the connector.

SHUTDOWN

1. Move the hydraulic system control valve to the "OFF" position.
2. Disconnect the hydraulic hoses from the tool—first the input (supply) hose, then the output (return) hose.
3. Insert plugs in the hose ends, couplers or tool ports, as applicable.
4. Wipe the tool thoroughly with a clean, dry cloth.

5. Clean any foreign matter or joint compound from the die holder surfaces.

COLD WEATHER OPERATION

If the tool is to be used during cold weather, preheat the hydraulic fluid at low engine speed. When using the normally recommended fluids, fluid temperature should be at or above 50°F/10°C (400 ssu/82 centistokes) before use.

Damage to the hydraulic system or compression tool can result from use with fluid that is too viscous or too thick.

STORAGE

Replace any damaged or missing safety labels and tags before storing the tool. Clean, dry and lubricate moving parts before storage. Store in a clean, dry place.

TOOL PROTECTION & CARE

NOTICE

In addition to the safety precautions in this manual, observe the following for tool protection and care.

- Make sure all couplers are wiped clean before connection.
- The hydraulic circuit control valve must be in the “OFF” position when coupling or uncoupling hydraulic tools. Failure to do so may result in damage to the quick couplers and cause overheating of the hydraulic system.
- Always store the tool in a clean dry space, safe from damage or pilferage.
- Make sure the circuit PRESSURE hose (with male quick disconnect) is connected to the “IN” port. The circuit RETURN hose (with female quick disconnect) is connected to the opposite port. Do not reverse circuit flow. This can cause damage to internal seals.
- Always replace hoses, couplings and other parts with replacement parts recommended by STANLEY. Supply hoses must have a minimum working pressure rating of 2500 psi/172 bar.
- Do not exceed the rated flow. Rapid failure of the internal seals may result. Refer to “SPECIFICATIONS” on page 16 for correct flow rate.
- Always keep critical tool markings, such as warning stickers and tags, legible.
- Do not force a small tool to do the job of a larger tool.
- Tool repair should be performed by experienced personnel only.
- Make certain that the recommended relief valves are installed in the pressure side of the system.
- Do not use the tool for applications for which it was not intended.

TROUBLESHOOTING

If symptoms of poor performance develop, the following chart can be used as a guide to correct the problem.

When diagnosing faults in operation of the tool, always check that the hydraulic power source is supplying the correct hydraulic flow and pressure to the grinder as listed in the table. Use a flow meter known to be accurate. Check the flow with the hydraulic oil temperature at least 80°F/27°C.

PROBLEM	CAUSE	SOLUTION
Tool does not operate.	Hydraulic hoses not connected properly.	Make sure hoses are connected and the couplers are tight.
	Hydraulic control valve OFF.	Turn the hydraulic system control valve ON.
	Hydraulic system not functioning.	Check hydraulic power unit for correct flow and pressure.
	Couplers or hoses blocked.	Remove obstruction.
	Pressure port check valve is installed in tool return port.	Install pressure port check valve in pressure port.
Tool operates in reverse (piston advances/retracts when trigger is squeezed.).	Hoses connected to wrong ports on tool.	Connect input (supply) line to IN port. Connect output (return) line to OUT port.
Tool under-crimps. Die load less than 10 tons/9072 kg.	Hydraulic system pressure too low.	Check hydraulic power source for correct flow and pressure.
	Relief valve set too low.	Increase relief valve pressure.
	Dirt or obstruction between dies.	Remove obstruction. Clean die area.
	Piston seal worn or damaged.	Contact an authorized STANLEY distributor.
	Improper die set for wire and connector.	Install proper die set.
Tool over-crimps. Die load more than 12 tons/10,886 kg.	Hydraulic system pressure too high.	Check hydraulic power source for correct flow and pressure.
	Relief valve set too high.	Decrease relief valve pressure.
Trigger difficult to operate.	Hoses connected to wrong ports on tool.	Connect input (supply) line to IN port. Connect output (return) line to OUT port.
	Excessive back pressure.	If back pressure is greater than 250 psi/17 bar, clear the return line obstruction or restriction.
	Trigger guard bent and binding on spool in bore.	Repair or replace trigger assembly.

SPECIFICATIONS

Capacity (depending on model).....	500 MCM Copper to 1033 MCM Aluminum
Crimping Force	12 tons @ 1650 psi / 10,886 kg @ 114 bar
Pressure Range.....	1650-2500 psi/114-172 bar
Flow Range	3-9 GPM/11-34 LPM
Optimum Flow	8 GPM / 30 LPM
Porting	3/8 NPT
Hose Whips & Couplers	No
Weight	17 lbs / 7.7 kg
Overall Length	22 inches / 56.9 cm
Overall Width.....	7 inches / 18 cm

AMERON
INTERNATIONAL
EVERYTHING UNDER PRESSURE™

CT10016N PARTS LIST

Item No.	Part No.	Qty	Description
1	00118	1	Retaining Ring
2	00144	14	Cap screw
3	07626	2	O-Ring
4	09330	1	O-Ring
5	00294	1	O-Ring
6	00360	1	O-Ring
7	00936	2	Adapter
8	01259	1	O-Ring
9	01521	2	Cap screw
10	01534	1	Roll Pin
11	01608	4	Steel Ball
12	01809	1	Valve Spool
13	01812	1	Valve Spool Screw
14	03014	1	Washer
15	67281	1	Cap screw
16	06324	1	Die Piston Assy.
17	06326	1	Washer
18	06332	1	O-Ring
19	66588	1	C-Frame, Head Unit 26mm Assembly (Includes Items 20, 42 & 44)
20	67279	1	Set Screw
21	16556	1	Spring
22	18050	1	Back-Up Ring
23	21424	1	Relief Valve
24	22147	2	Cap screw
25	38622	1	Valve Sleeve
26	39925	1	Compression Spring
27	39939	1	Valve Handle
28	51182	1	Trigger Guard
29	51183	1	Trigger
30	52534	2	Setscrew
31	58439	1	Adapter
32	58440	1	Retaining Ring
33	58441	1	Sleeve
34	58442	1	Oil Tube
35	58480	1	Piston
36	58485	1	O-Ring
37	58493	1	Cylinder
38	67276	1	Cylinder Head (See Note 1)
39	76652	1	Sticker

Item No.	Part No.	Qty	Description
40	58583	1	T-Seal
41	58594	1	Retaining Ring
42	67277	1	Set Screw
43	67259	1	Check Valve Assembly
44	67280	1	Key
SK1	58551	1	Seal Kit (Includes Items 3-6, 8, 18, 22, 36 & 40)

Note 1: Item 38 can be identified by measuring the length of the threads (see figure below). The length of threads for item 38 is 1.100 inches and the thread diameter is M60x1.5. For older models consult the factory.

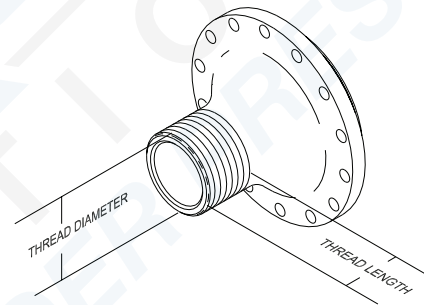

To determine which model you have, measure the thread length and diameter on the cylinder head. Older models have different cylinder head dimensions.

CT10016N		
CYL HEAD P/N	THREAD LENGTH	THREAD DIAMETER
67276 (ITEM 38)	1.100	M60X1.5

CT10056DH PARTS ILLUSTRATION

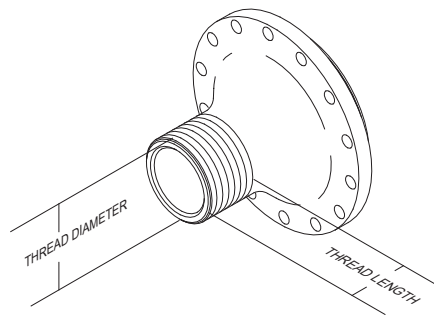

THIS IS AN NEWER MODEL CYLINDER HEAD AND C-FRAME. THE CYLINDER HEAD (ITEM 38) HAS A THREAD DIAMETER OF M60X1.5 (METRIC) AND A THREAD LENGTH OF 1.100. CHECK THESE DIMENSIONS ON YOUR CYLINDER HEAD BEFORE ORDERING PARTS TO MAKE SURE YOU ARE ORDERING THE CORRECT PARTS.

THIS IS AN NEWER MODEL CYLINDER HEAD AND C-FRAME. THE CYLINDER HEAD (ITEM 48) HAS A THREAD DIAMETER OF M60X1.5 (METRIC) AND A THREAD LENGTH OF 1.750. CHECK THESE DIMENSIONS ON YOUR CYLINDER HEAD BEFORE ORDERING PARTS TO MAKE SURE YOU ARE ORDERING THE CORRECT PARTS.

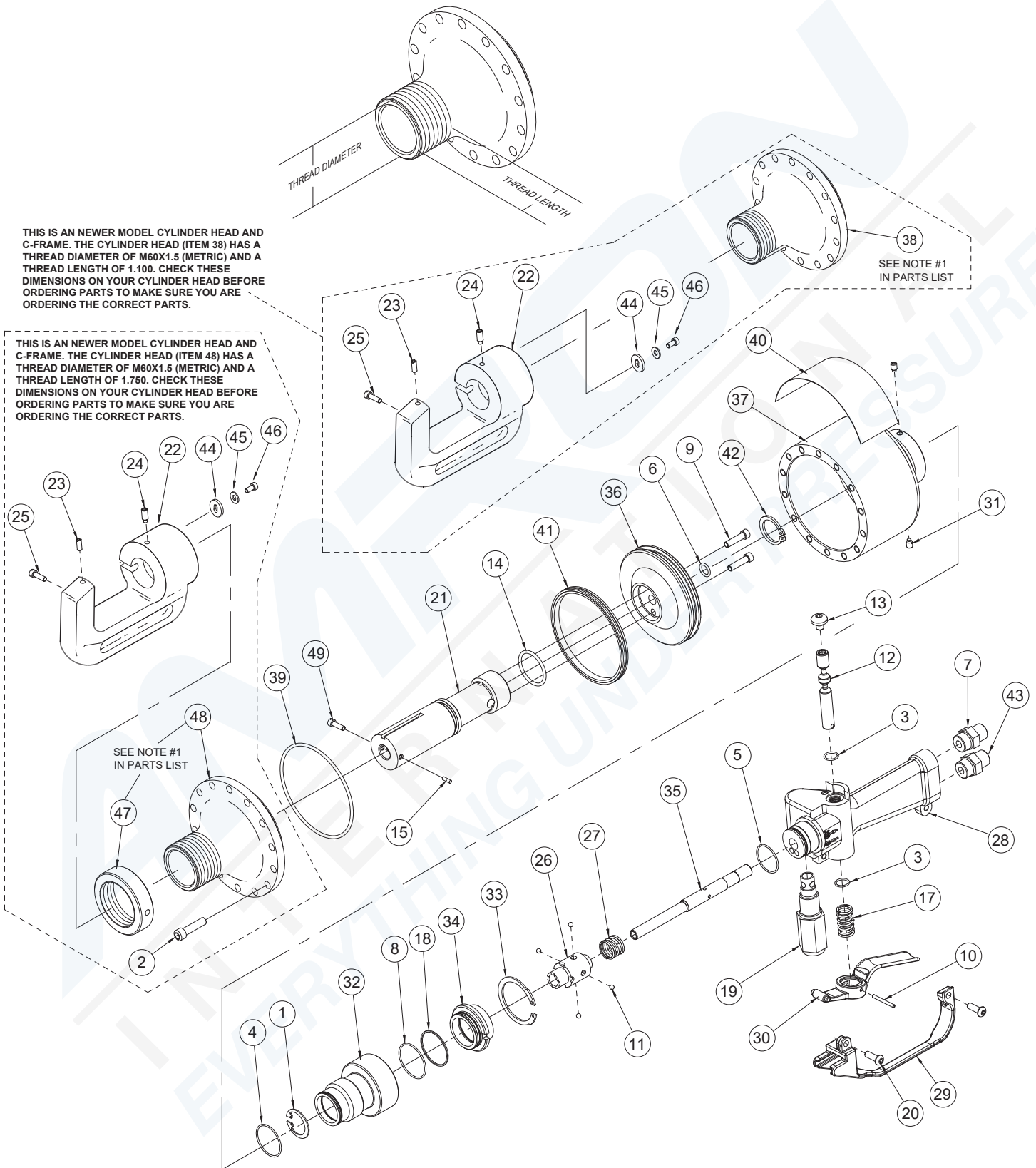

CT10056DH PARTS LIST

Item No.	Part No.	Qty	Description
1	00118	1	Retaining Ring
2	00144	14	Cap screw
3	07626	2	O-Ring
4	09330	1	O-Ring
5	00294	1	O-Ring
6	00360	1	O-Ring
7	00936	2	Adapter
8	01259	1	O-Ring
9	01521	2	Cap screw
10	01534	1	Roll Pin
11	01608	4	Steel Ball
12	01809	1	Valve Spool
13	01812	1	Valve Spool Screw
14	06332	1	O-Ring
15	08337	1	Ball Detent
17	16556	1	Spring
18	18050	1	Back-Up Ring
19	21424	1	Relief Valve
20	22147	2	Cap screw
21	24446	1	Push Rod
22	67264	1	C-Frame (Includes Items 23-25 & 46)
23	67278	1	Ball Plunger
24	68272	1	Setscrew
25	67282	1	Cap screw
26	38622	1	Valve Sleeve
27	39925	1	Compression Spring
28	39939	1	Valve Handle
29	51182	1	Trigger Guard
30	51183	1	Trigger
31	52534	2	Setscrew
32	58439	1	Adapter
33	58440	1	Retaining Ring
34	58441	1	Sleeve
35	58442	1	Oil Tube
36	58480	1	Piston
37	58481	1	Cylinder
38	67276	1	Cylinder Head (See Note 1)
39	58485	1	O-Ring
40	76652	1	Sticker

Item No.	Part No.	Qty	Description
41	58583	1	T-Seal
42	58594	1	Retaining Ring
43	67259	1	Check Valve Assy
44	06326	1	Washer
45	03014	1	Washer
46	67281	1	Cap screw
47	68318	1	Jam Nut (See Note 1)
48	68317	1	Cylinder Head (See Note 1)
49	25837	1	Slotted Mod. Cap screw
SK	58551	1	Seal Kit (Includes Items 3-6, 8, 14, 18, 39 & 41)

NOTE 1: Item 48 is used with a jam nut (item 47) whereas item 38 does not use a jam nut. Item 38 and 48 can be identified by measuring the length of the threads (see figure below). The length of threads for item 38 is 1.100 inches. For item 48 the length is 1.750 inches. For older models consult the factory.

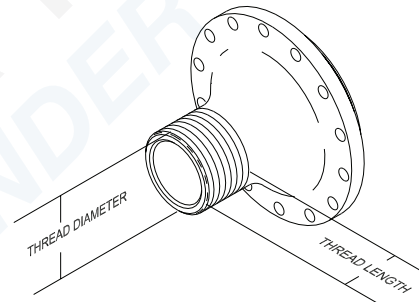

To determine which model you have, measure the thread length and diameter on the cylinder head.

CYL HEAD P/N	THREAD LENGTH	THREAD DIAMETER
67276 (ITEM 38)	1.100	M60X1.5 (METRIC)
68317 (ITEM 48)	1.750	M60X1.5 (METRIC)

CT10056N PARTS ILLUSTRATION

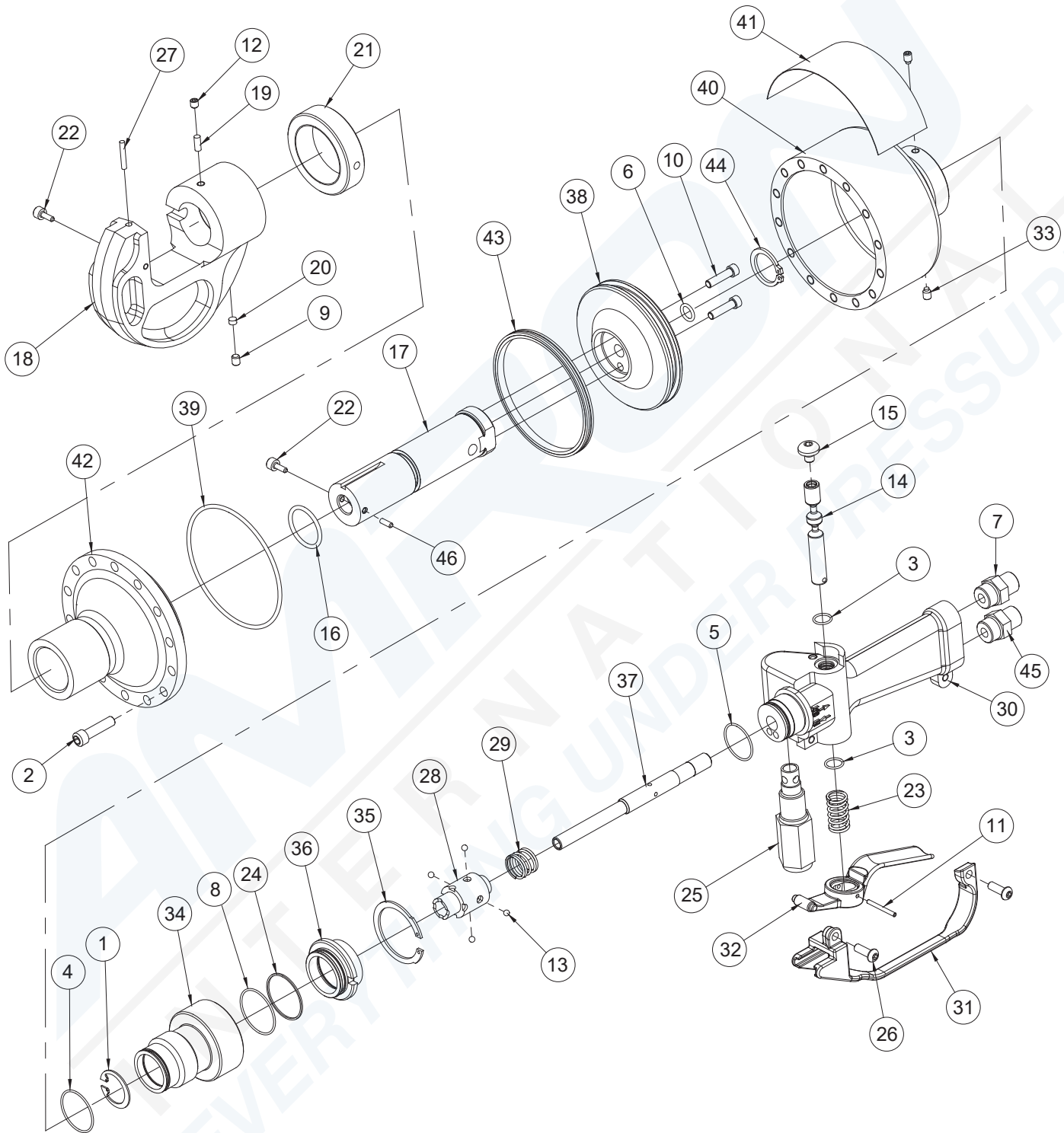

CT10056N PARTS LIST

Item No.	Part No.	Qty	Description
1	00118	1	Retaining Ring
2	00144	14	Cap screw
3	07626	2	O-Ring
4	09330	1	O-Ring
5	00294	1	O-Ring
6	00360	1	O-Ring
7	00936	2	Adapter
8	01259	1	O-Ring
9	01397	1	Setscrew
10	01521	2	Cap screw
11	01534	1	Roll Pin
12	01607	1	Setscrew
13	01608	4	Steel Ball
14	01809	1	Valve Spool
15	01812	1	Valve Spool Screw
16	04795	1	O-Ring
17	08330	1	Push Rod
18	08334	1	C-Frame
19	08335	1	Pin - Kearney
20	08336	1	Plug - Kearney
21	09906	1	Jam Nut
22	12430	2	Cap screw
23	16556	1	Spring
24	18050	1	Back-Up Ring
25	21424	1	Relief Valve
26	22147	2	Cap screw
27	34133	1	Spring Plunger
28	38622	1	Valve Sleeve
29	39925	1	Compression Spring
30	39939	1	Valve Handle
31	51182	1	Trigger Guard
32	51183	1	Trigger
33	52534	2	Setscrew
34	58439	1	Adapter
35	58440	1	Retaining Ring
36	58441	1	Sleeve
37	58442	1	Oil Tube
38	58480	1	Piston
39	58485	1	O-Ring
40	58493	1	Cylinder

Item No.	Part No.	Qty	Description
41	76652	1	Sticker
42	58513	1	Cylinder Head
43	58583	1	T-Seal
44	58594	1	Retaining Ring
45	67259	1	Check Valve Assembly*
46	08337	1	Spring Plunger
SK1	58551	1	Seal Kit (Includes Items 3-6, 8, 16, 24, 39, & 43)

CT10066AN PARTS ILLUSTRATION

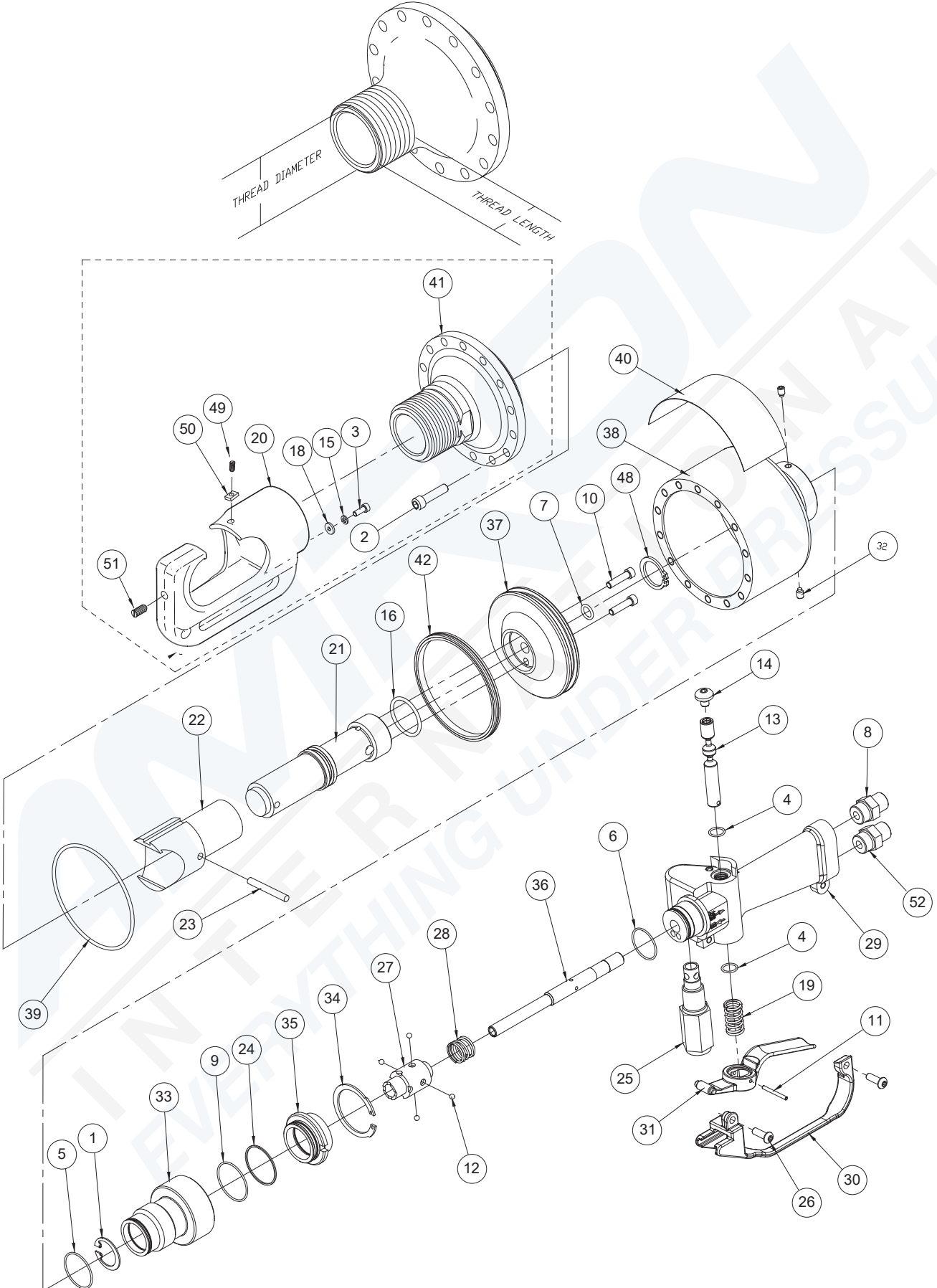

CT10066AN PARTS LIST

Item No.	Part No.	Qty	Description
1	00118	1	Retaining Ring
2	00144	14	Cap screw
3	67281	1	Cap screw
4	07626	2	O-Ring
5	09330	1	O-Ring
6	00294	1	O-Ring
7	00360	1	O-Ring
8	00936	2	Adapter
9	01259	1	O-Ring
10	01521	2	Cap screw
11	01534	1	Roll Pin
12	01608	4	Steel Ball
13	01809	1	Valve Spool
14	01812	1	Valve Spool Screw
15	03014	1	Washer
16	06332	1	O-Ring
18	06326	1	Washer
19	16556	1	Spring
20	79298	1	C-Frame (Includes Items 3, & 49-51)
21	17678	1	Push Rod
22	67248	1	Ram Assembly
23	17681	1	Spring Pin
24	18050	1	Back-Up Ring
25	21424	1	Relief Valve
26	22147	2	Cap screw
27	38622	1	Valve Sleeve
28	39925	1	Compression Spring
29	39939	1	Valve Handle
30	51182	1	Trigger Guard
31	51183	1	Trigger
32	52534	2	Setscrew
33	58439	1	Adapter
34	58440	1	Retaining Ring
35	58441	1	Sleeve
36	58442	1	Oil Tube
37	58480	1	Piston
38	58481	1	Cylinder
39	58485	1	O-Ring
40	76652	1	Sticker

Item No.	Part No.	Qty	Description
41	67276	1	Cylinder Head
42	58583	1	T-Seal
48	58594	1	Retaining Ring
49	67279	1	Setscrew
50	67280	1	Key
51	67277	1	Setscrew
52	67259	1	Check Valve Assembly
SK1	58551	1	Seal Kit (Includes Items 4-7, 9, 16, 24, 39 & 42)

If you have an older CT10066AN, Before ordering parts for the cylinder head or C-frame parts, contact a STANLEY Infrastructure customer service representative to ensure the correct parts are being ordered. Older models could have different size cylinder head and C-frame.

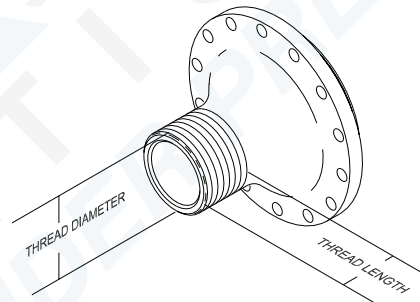

To determine which model you have, measure the thread length and diameter on the cylinder head.

CT10066AN		
CYL HEAD P/N	THREAD LENGTH	THREAD DIAMETER
67276 (ITEM 41)	1.100	M60X1.5

STANLEY®

STANLEY Infrastructure
6430 SE Lake Road
Portland, Oregon 97222 USA
(503) 659-5660 / Fax (503) 652-1780
www.stanleyinfrastructure.com