

Instruction Manual
for
Amron International, Inc.

**Model 8111 AMCOMMAND I
One Diver Air Control System**

S/N: _____



1380 Aspen Way, Vista California 92081-8349
United States of America
Phone: (760) 208-6500
Fax (760) 599-3857
email: sales@amronintl.com
web: www.amronintl.com

This manual and the information contained herein are provided for use as an operation and maintenance guide. No license or rights to manufacture, reproduce, or sell either the manual or articles described herein are given. Amron International, Inc. reserves the right to change specifications without notice.

TABLE OF CONTENTS

1. SPECIFICATIONS..... 1

 1.1 Air Control 1

 1.2 Depth Monitoring (Pneumo)..... 1

 1.3 Communications 2

 1.4 Enclosure 2

2. GENERAL INFORMATION..... 3

 2.1 Air Control 3

 2.2 Depth Monitoring (Pneumo)..... 3

 2.3 Communication System 4

 2.4 AMCOMMAND I, Model 8111 5

3. SAFETY AND REGULATIONS..... 6

 3.1 Diving Safety and Regulations 6

 3.2 Personnel Requirements 7

 3.3 Air Supply Requirements 7

 3.4 Calibration, Service and Inspection 8

4. OPTIONS AND ACCESSORIES..... 9

 4.1 Heat Wrap Option 9

 4.2 Amron Heavy-Duty Headset - Model 2401-28..... 9

 4.3 Amron Standard Headset - Model 2460-28 9

 4.4 Amron Push-to-Talk Microphone - Model 2405-28..... 9

 4.5 Amron Remote Walk-and-Talk Module 2822-28 9

 4.6 Amron Remote Push-to-Talk Module - Model 2821-28 9

 4.7 Audio Adaptor Cable - Amron Part Number 180-1000-00..... 10

 4.8 DIN Adapter 300 Bar - Amron Part Number HAS-300D 10

5. WARRANTY & SERVICE POLICY 11

 5.1 Limited Warranty 11

 5.2 Service Policy 11

6. CONTROLS & CONNECTIONS 12

 6.1 Air Control 12

 6.2 Depth Monitoring..... 14

 6.4 Communications 16

 6.5 Drawing, Front Panel Communicator..... 20

7. PRE-DIVE PROCEDURES..... 21

 7.1 Pre-Dive Set-Up..... 21

 7.2 Pre-Dive Check Out 21

 7.3 Pre-Dive Pneumo Test..... 22

 7.4 Pre-Dive Testing Communications 23

 7.5 Connecting Diver Umbilical..... 23

 7.6 Low Pressure Supply 24

| | |
|--|-----------|
| 8. OPERATING PROCEDURES | 25 |
| 8.1 Low Pressure Breathing Air (Primary Supply) | 25 |
| 8.2 High Pressure Breathing Air (Primary Supply) | 25 |
| 8.3 Pre-Operation Checklist..... | 26 |
| 8.4 Pneumo Readings | 27 |
| 8.5 Diver Communications – Power on Battery Check 2810E-8111 | 28 |
| 8.6 2-Wire Operation..... | 29 |
| 8.7 Diagram, 2-Wire Set-Up Instructions | 31 |
| 8.8 FULL DUPLEX (4-Wire) Operation | 32 |
| 8.9 Diagram, 4-Wire Set-Up Instructions | 33 |
| 8.10 Full Duplex (4-Wire) - What, Why and How | 34 |
| 8.11 How Do You Use Full Duplex (4-Wire) | 37 |
| 8.12 Diagram, Push-to-Talk Microphone | 39 |
| 8.13 To Operate and/or Check Out FULL DUPLEX | 40 |
| 8.14 Battery Replacement, Part No. 2890-05..... | 41 |
| 9. THEORY OF OPERATION | 42 |
| 9.1 Mechanical | 42 |
| 9.2 Flow Diagram, Model 8111 Air Control | 45 |
| 9.3 Electrical..... | 46 |
| 10. MAINTENANCE | 48 |
| 10.1 Review of Scheduled Maintenance | 48 |
| 10.2 Scheduled Maintenance | 48 |
| 11. TROUBLESHOOTING AND REPAIR | 50 |
| 11.1 General Information | 50 |
| 11.2 Air Control | 50 |
| 11.3 Depth Monitoring..... | 53 |
| 11.4 Diver Communications..... | 53 |
| 11.5 Troubleshooting | 55 |
| 12. REFERENCE MATERIAL..... | 57 |
| 12.1 Diving Log, U.S Navy (Chart) | 57 |
| 12.2 Repetitive Dive Worksheet..... | 58 |
| 12.3 No Decompression Limits | 59 |
| 12.4 Gauge Pressure For | 60 |
| 12.5 Equivalent Depths of Seawater & Fresh Water | 61 |
| 13. DRAWINGS | 62 |
| 13.2 Parts Locator, Air Control Panel 8111 (Back)..... | 64 |
| 13.3 Parts Locator, Communicator | 65 |
| 13.4 Parts Locator, Regulator Model 44-2214-244-1068 | 66 |

| | |
|--|-----------|
| 14. PARTS LIST..... | 66 |
| 14.1 AMCOMMAND I Air Control Delivery System | 68 |
| 14.2 8111-300 Case Assembly..... | 68 |
| 14.3 8111-400 Air Control Panel Assembly..... | 68 |
| 14.4 8111-500 HP Yoke & Hose Assembly | 69 |
| 14.5 Recommended Spare Parts for Air control | 70 |
| 14.6 44-2214-244-1068 Regulator Assembly | 70 |
| 14.7 2810E-8111 Communicator Assembly | 71 |
| 14.8 2405-28 Hand Held Microphone – Push-to-Talk | 71 |
| 14.9 2810A-FS-01 Field Spares Kit for Model 2810E-8111 | 72 |
| 15. REPAIR & CALIBRATION LOGS..... | 73 |
| 15.1 Repair and Maintenance Log for Model 8111 | 73 |
| 15.2 Gauge Calibration Log Model 25545-23B11-HDP | 74 |

1. SPECIFICATIONS

1.1 Air Control

1.1.1 High Pressure Input

Input Pressure Range 500-3000 PSI with standard CGA850 Yoke Connections

***500-4500 PSI with optional 300 Bar DIN Adapters

Inlet Valve (Source Select) 2

Gauge - 0-5000 PSI Accuracy +/- 1.5%

Check Valve, prevents reverse inlet flow 2

Input Filter, In Line Pre Regulator 50 Micron

*** Available with optional 300 Bar DIN Adapters, Amron Part No. HAS-300D ***

1.1.2 High Pressure Regulator, Tescom

Outlet Pressure Range 0-285 PSI

High Flow Cv = .06

Max Pressure 4500 PSI

1.1.3 Low Pressure Input, with Check Valve

Max Pressure 255 PSI

Diver Outlet Connection, (O2 Fitting) 1

Diver Outlet Valve 1

Air Pressure Gauge, 0-400 PSI Accuracy +/- 1.5% of Full Scale

Over Pressure Relief Valve Set Pressure 285 PSI

1.1.4 Panel

Material Stainless Steel

Powder Coating Black Textured Semi-Gloss Polyester

Silkscreen Graphics Red, White & Blue

1.2 Depth Monitoring (Pneumo)

1.2.1 Pneumo Gauge

Mirrored Scale, 6 Inch 1

Range Dual Scale 0-250 FSW/0-76 MSW

Divisions 1 Foot

Accuracy 0.25% of Full Scale

| | | |
|-------|--------------------------------------|---|
| 1.2.2 | Pneumo Valve | |
| | Regulating Valve, KEL-F Seat | 1 |
| 1.2.3 | Outlet Connection | |
| | O2 Fitting Chrome Plated Brass | 1 |

1.3 Communications

| | | |
|-------|--|-------------------------------------|
| 1.3.1 | AMCOM I , Model 2810E-8111 1-Diver Communicator | |
| | Input Impedance (Microphone Inputs) | 300 Ohms |
| | Power Frequency Response | 300 – 4000Hz |
| | Common Mode Rejection (minimum) | 40dB |
| | Entertainment Input Impedance | >47 kOhms |
| | Current Drain Maximum Full Volume | 3 Amps |
| | Typical Quiescent | 55 mAmps |
| | Minimum Load Impedance | 2 Ohms |
| | Sensitivity (Input) | 1.8 mVRMS |
| | Maximum Output Power (4 Ohm Load, 14 VDC) | 20 Watts |
| | Operating Voltage | 115-220 Volts AC 50/60Hz |
| | Operating Time on Rechargeable Battery | Nominal 85 Hours |
| | Panel Material | Stainless Steel |
| | Powder Coating | Black Texture, Semi-Gloss Polyester |
| | Silkscreen Graphics | White |

1.4 Enclosure

| | | |
|-------|---|-------------------------------|
| 1.4.1 | Case Material | |
| | Co-polymer composite material including carrying handle & latches with stainless steel hardware | |
| 1.4.2 | Yoke Storage | |
| | HP hoses and yokes remain attached to unit and are stored on inside of lid. | |
| 1.4.3 | Case | |
| | Lid closed | 20-1/2" W x 17" D x 8-1/2" H |
| | Lid Open | 20 1/2" W x 18.3/4" D x 23" H |
| | Weight: | Approximately 45 lbs. |
| | Color: | International yellow |

2. GENERAL INFORMATION

The AMRON AMCOMMAND I, Model 8111 is a portable self-contained one diver high and low pressure air control, communication and pneumo system. The package is a durable co-polymer composite shell providing a convenient, compact, rugged and professional unit.

2.1 Air Control

The air control section consists of two high pressure inputs, a single low pressure input, and a single diver air output connection.

Standard 3000 PSI MAX Input - Model 8111 comes standard with 2 each CGA850 yokes attached to 6-foot long HP hoses. The CGA850 yoke limits the maximum input pressure to 3000 PSI

Optional 4500 PSI MAX Input - Installing the 300 Bar DIN Adapters, Amron Part No. HAS-300D, will increase the 8111 maximum input pressure limit to 4500 PSI. Simply remove CGA850 yoke nut and yoke from the bleeder body, screw on the 300 Bar DIN adapters, and tighten with a wrench. Each input has a shut-off valve and 0-5000 psi gauge.

The high pressure inputs include two scuba bottle yokes with 6 foot hose whips. Each input has a shut off valve and 0-5000 psi gauge, input pressure range is 500 to 4500 PSI.

Check valves provide protection against back flow of air from a full bottle to an empty, when switching HP bottles. High pressure air is reduced to desired low pressure via a TESCOM adjustable regulator. The input to the regulator is protected against contamination by a 50 micron filter. Regulator output pressure is adjustable over the range of 0 to 255 psi; a 2 1/2" 0-400 psi gauge monitors the output pressure. The unit has an over pressurization relief valve, factory set to 285 psi.

The low pressure input is #6 JIC (3/8), and has a check valve to permit simple switch over from low pressure air to high pressure air.

Divers air hose connection is O2 fitting, control is via a 1/4 turn ball valve permitting unrestricted flow.

2.2 Depth Monitoring (Pneumo)

The diver's pneumo connection is an O2 fitting, pneumo valve is regulating type. Pneumo gauge is 3-D INSTRUMENTS, 6" high precision 0.25% of full scale accuracy, dual scale 0-250 FSW/0-76 MSW with 1 foot increments. A gauge protector is installed in line with the pneumo gauge.

2.3 Communication System

The 2810E-8111 AMCOMMAND I includes a full featured, one-diver, hardwire communicator that uses state-of-the-art electronics to provide industry leading features for maximum audio clarity. The communicator increases battery life over previous models by using a digital audio power amplifier. This power amplifier delivers an industry leading 20 Watts of audio power, more than enough to provide clear communications in difficult conditions. An improved audio filtering network maximizes audio clarity and results in improved communications. The communicator also include a set of auxiliary audio input jacks that allows the diver to listen to audio from an MP3 player while remaining in constant communications with the tender. This feature is only available when the diver is using Full Duplex (4-wire) mode. This unit is powered by an internal rechargeable battery with a typical battery life of 85 hours (dependent on the age of the battery, the usage pattern, and temperature). An internal battery charger simplifies maintenance and eliminates the need to carry a separate piece of equipment.

As with all Amron diver communicators, the AMCOMMAND I can operate in 2-Wire or Full Duplex (4-Wire) modes. There is a single volume control for the up-link (DIVER-TO-TENDER) and another control for the down-link (TENDER-TO-DIVER). Designed for a long and dependable service life, the front panel is powder coated, stainless steel and the system uses a waterproof speaker and heavy-duty switches with waterproof seals. There is a BATTERY CONDITION INDICATOR located on the front panel. A steady green light means the battery charge is greater than 30% of full charge. The LED will start blinking when the battery reaches 30% remaining life of approximately 24 hours remaining life. This should provide enough time to safely complete a diving operation even if the LED starts blinking soon after the start. To maximize service life, it is recommended that the battery be recharged as soon as possible after the BATTERY CONDITION INDICATOR starts blinking.

The AMCOMMAND I communicator comes with the Amron Model 2405-28 PUSH-TO-TALK hand-held microphone. Using this microphone in place of the PANEL SPEAKER can significantly improve communications. When the PUSH-TO-TALK button on the microphone is pressed, the PANEL SPEAKER is automatically disconnected thus cutting out a majority of the background noise that could have been sent to the diver.

Amron offers two optional headset accessories that allow the tender to move about and still maintain contact with the diver. The first is the Model 2822-28 Remote Walk-and-Talk module. It is designed for Full Duplex (4-Wire) operations. The second is the Model 2821-28 Remote Push-to-Talk module. It is designed for 2-Wire applications or situations where the tender may be operating in a high noise environment. Both modules come with 25 feet (7.6 meters) of lightweight cable (custom lengths available).

2.4 AMCOMMAND I, Model 8111



3. SAFETY AND REGULATIONS

Safe diving does not happen by accident. There are few occupations in the world which require such a broad range of knowledge and training as diving. There are many diverse factors which can affect diving safety, i.e. planning, weather, equipment, location, water conditions, as well as the type of work being done. The single most important factor in eliminating accidents is planning and attention to detail. Diving knowledge, training and experience are fundamental elements needed to execute a safe dive.

The following reference materials are recommended as sources of information for running a safe diving operation:

1. U.S. Department of Labor, OSHA Regulations 1910.401 Sub-part T–Commercial Diving Operations.
2. U.S. Navy Diving Manual.
3. Divers Handbook of Underwater Calculations.

3.1 Diving Safety and Regulations

3.1.1 Diving Regulations

Several codes and regulations cover diving operations and procedures. In the United States most commercial diving operations are covered by the OSHA (Occupational Safety and Health Administration) regulations, or individual state regulations, which are adopted from the federal regulations, and made a part of the civil code.

While government agencies are exempt from OSHA regulations, they generally fall under other regulations, which are similar or stricter than OSHA. If they are completely exempt, they must still abide by the procedures for operating a safe dive.

While no agency (within the U.S., for commercial diving operations) tests or approves equipment for use, they do establish minimum standards which should be followed. The suitability of a given piece of equipment for a particular task is left to the supervisor of the dive. The following information is extracted from the OSHA regulations for commercial diving operations.

NOTE: The information is not presented as a direct or complete quotation, but rather as our interpretation of the regulations. Each diving supervisor should obtain a copy of these regulations for their own use.

Copies of the complete section of Commercial Diving Operations are available from Amron International for a nominal charge.

WARNING: DO NOT USE THE AMCOMMAND I FOR THE FOLLOWING:

- Mixed gas diving operations with an oxygen level greater than 26%.
- Oxygen or oxygen enriched breathing mixtures above 26%.

The AMCOMMAND I is not designed or intended for these applications.

3.2 Personnel Requirements

1. Each dive team member shall have the experience or training necessary to perform assigned tasks in a safe and healthful manner. The person operating the AMCOMMAND I must be trained in the proper operating procedures and emergency operating procedures.
2. It is the responsibility of the designated person in charge of the diving operation to be on site at all times. He is responsible for all aspects of the diving operation affecting the health and safety of dive team members.
3. The dive shall be terminated when:
 - A diver requests termination.
 - A diver fails to respond to instructions.
 - Diver communications are lost and cannot be re-established quickly.
 - A diver begins to use diver carried back-up breathing air or location reserve breathing air.
 - Operational conditions deteriorate to a point where safe diving cannot be guaranteed.

3.3 Air Supply Requirements**WARNING**

Regardless of the type of air supply being used for surface supplied diving; the diver must always have a back-up supply of air. Generally this is in the form of a bailout bottle. The back-up air supply must be adequate to return the diver to the surface; if the dive requires in-water decompression, this must be accounted for also.

1. The diver's air supply may originate from a low-pressure air compressor, high-pressure air cylinders, or a combination of both. Regardless of the source, the air must meet certain established standards of purity and must be supplied in an adequate volume for breathing.

2. The air supply requirements depend upon the specific factors of each dive such as depth, duration, level of exertion, and type of diving system (helmet/hat) being used. It is the dive supervisor's responsibility to ensure that an adequate supply of air is available and on site for the planned dive. This includes sufficient back up air to safely return the diver to the surface in the event the primary supply of air is lost.
3. Low-pressure compressors used for breathing air should be specifically designed for diving. Compressors used to supply air to the divers shall be equipped with a volume tank which has a check valve on the inlet side, a pressure gauge, relief valve, drain valve, and a proper filtration system. The output of the air compressor system shall be tested for air purity every 6 months by means of an air sample.
4. Air compressor intakes shall be located away from and up wind of areas containing exhaust or other contaminants.
5. **NOTE:** OSHA regulations require a decompression chamber capable of recompressing the diver at the surface to a minimum of 165 FSW (6 ATA) shall be available at the dive location for a surface supplied air diving to depths deeper than 100 FSW.

3.4 Calibration, Service and Inspection

1. Each depth gauge shall be dead weight tested or calibrated against a master reference gauge every 6 months or if there is a discrepancy greater than two percent (2%) between any two equivalent gauges.
2. Each equipment modification, repair, test, calibration, or maintenance service shall be recorded by means of a tagging or logging system, and include the date and nature of work performed, and the name of the person performing the work. For your convenience a repair service log is provided at the end of this manual.
3. Equipment Inspection; Prior to each dive, the equipment shall be inspected and checked to ensure that it is in proper working order.

4. OPTIONS AND ACCESSORIES

4.1 Heat Wrap Option

The 8111-H includes an 18 foot heating cable that will allow for diving in air temperatures below 45 degrees. The heating cable is wrapped around the HP input and regulator section located on the backside of the manifold panel. This 120 VAC heater comes with a standard NEMA 5-15P 3-prong plug and 2 ft. long GFCI in-line device. The plug is located on the front panel for ease of use. This is a different power connection than that used by the diver communicator. The heater requires 120VAC; if you are using 220VAC power then you will need a voltage converter with a minimum rating of 500W.

4.2 Amron Heavy-Duty Headset - Model 2401-28

The Model 2401-28 is a heavy-duty headset with boom microphone. It comes equipped with color-coded, dual banana plugs that mate directly to AMCOM diver communicators. It includes a 6 ft. straight cord (1.8 meters).

4.3 Amron Standard Headset - Model 2460-28

The Model 2460-28 is a light and comfortable headset designed for extended wear at an economical price. It comes equipped with color-coded, dual banana plugs that mate directly to AMCOM diver communicators as well as a spiral cord that can be extended up to 8 feet (2.4 meters).

4.4 Amron Push-to-Talk Microphone - Model 2405-28

The Model 2405-28 is a hand-held, noise canceling, push-to-talk microphone that provides excellent sound quality to the diver. It comes equipped with a spiral cord that can be extended up to 6 feet (1.8 meters)

4.5 Amron Remote Walk-and-Talk Module 2822-28

Designed for Full Duplex (4-Wire) applications, the Model 2822-28 provides the tender with mobility around the dive site while maintaining communications with the diver. It comes equipped with a small clip-on belt module that contains the connectors for the headset, and 25 feet (7.6 meters) of lightweight flexible cable. Custom cable lengths are available

4.6 Amron Remote Push-to-Talk Module - Model 2821-28

Designed for 2-Wire applications, the Model 2821-28 provides the tender with mobility around the dive site while maintaining communications with the diver. It comes equipped with a small clip-on belt module that contains a Push-to-Talk switch, connector for the headset, and 25 feet (7.6 meters) of lightweight flexible cable. Custom cable lengths are available.

4.7 Audio Adaptor Cable - Amron Part Number 180-1000-00

A 2 meter long cable with two RCA Phono plugs that connect the auxiliary audio input to a standard 3.5 mm stereo phone plug which mates to the headphone jack of most common portable audio devices

4.8 DIN Adapter 300 Bar - Amron Part Number HAS-300D

Converts a standard Amron CGA850 yoke (3000 PSI) to 300 Bar DIN (4500 PSI) use.

5. WARRANTY & SERVICE POLICY

5.1 Limited Warranty

Amron warrants that its manufactured products are free from defects in material and workmanship under normal use and service, as described in all literature covering the products for a period of 90 days from date of shipment. Amron's obligations under this warranty are limited to the repair of, or replacement of materials at Amron's discretion. This warranty shall not cover defects which are the result of misuse, negligence, accident, repair, or alterations.

5.2 Service Policy

For technical assistance or to request a repair, please call (760) 208-6500, Monday – Friday, 8 a.m. to 5 p.m. PT. Have the model number and serial number handy and be prepared to offer as much information as possible about the problem.

Please do not return any product without obtaining a return authorization number. Detailed instructions will be provided at the time of request.

6. CONTROLS & CONNECTIONS

Before using the AMCOMMAND I Model 8111, familiarize yourself with its operating controls and connections. For simplicity, the controls and connections are divided into three categories. The categories are Air Control, Pneumo, and Communications.

6.1 Air Control

The Air Control section consists of a high-pressure section and a low-pressure section. The system is designed to supply breathing air to a diver through an umbilical. This is known as surface supplied diving. The air the divers are breathing is supplied from the surface.

6.1.1 Standard 3000 PSI MAX Input

All models come standard with 2 each Amron CGA850 yokes attached to 6-foot long HP hoses. The CGA850 yoke limits the maximum input pressure to 3000 PSI.

6.1.2 Optional 4500 PSI MAX Input

Installing the 300 Bar DIN Adapters: Amron Part No. HAS-300D will increase the 8111 to a maximum input pressure limit to 4500 PSI. Simply remove Amron CGA850 yoke nut and yoke from bleeder body, screw on 300 Bar DIN adapter and tighten with a wrench

6.1.3 High-Pressure

The 8111 accepts breathing air from SCUBA bottles or any other suitable source, i.e. high-pressure flasks. The pressure is reduced to a level suitable to the needs of the diver via a pressure-reducing regulator. The pressure required by the diver is determined by the type of helmet/hat being used and the depth the diver is working at. The general rule of thumb is bottom pressure plus over-bottom pressure required for a given type of diving helmet/hat. Consult your diving helmet/hat manufacture/manual for the requirement of the helmet / hat you are using.

The High-Pressure section has two inputs, complete with high-pressure hose whips, CGA850 SCUBA bottles yokes, and pressure reducing regulator.

1. Source select inlet valve handles are color coded Red and Blue to correspond to the hose whips which are also color-coded Red and Blue. This helps the operator identify which valve controls which tank. For maximum airflow, turn handle counter clockwise four (4) full turns. To shut-off valve, turn handle clockwise until it stops.
2. Inlet gauge reads actual input pressure of air source. Gauge pressure range is 0-5000 psi; accuracy is 1-1/2% of full scale.
3. Check valves (HP section) prevent input air from one source flowing into a second lower pressure source when both source valves are

open. This simplifies the switch over from one SCUBA bottle to another. **NOTE:** If both source valves are left open with full bottles the bottles will be drawn from equally.

4. The Amron CGA850 input yokes are standard with bleed valves and color-coded 6-ft. high-pressure hose whips. The CGA850 input yokes are limited to maximum pressures of 3000 PSI and fit standard SCUBA bottle valves.
5. A pre-regulator filter prevents debris from contaminating the regulator. Filter element is 50 micron.
6. High pressure TESCO regulator(s) reduce pressure of incoming air from high-pressure bottles to a level required by diver's helmet / hat. To increase the diver's air pressure, turn knob clockwise to desired setting. To decrease the diver's air pressure, turn knob counter clock-wise. **NOTE:** Regulator is a non-venting type; in order to reduce the set pressure, air must be flowing through the regulator.

6.1.4 Low-Pressure

The Low-Pressure section consists of an LP input, low pressure output of regulator, LP gauge, and diver connection. A small portion of the LP air is also used when diver depth measurements are made.

Accepts breathing air from a low-pressure source i.e., a low pressure diving air compressor. Note: The low-pressure section does not regulate the air pressure to the diver. The compressor must be set to provide the proper pressure to the diver.

Breathing air from the low-pressure side of the regulator or the low-pressure input is routed to the diver's breathing air connections. A portion of the low-pressure air is used by the pneumo section for diver depth measurements.

1. Low-pressure input, #6 JIC type fitting. (O₂ type fitting available).
2. Low-pressure check valve prevents the back flow of air from the HP regulator output into the LP air source. This also permits simple switch over from LP to HP air
3. 1/4 Turn ball valve controls flow of air to diver. Ball valve permits unrestricted flow.
4. Divers air supply gauge reads air pressure to divers, 0-400 PSI.
5. Diver's air supply outlet connection, O₂ (oxygen) type fitting. (37° JIC optional).
6. Pressure relief valve, factory set for 285 PSI, vents excess pressure to atmosphere. Vent is located between diver output connections.

6.2 Depth Monitoring

The Pneumo Fathometer section is used to measure the diver's depth. Pneumo readings are made by pressurizing the diver's pneumo hose. Air is forced through the pneumo hose until all water is displaced. The pneumo valve is shut off and the pressure is read on the high accuracy depth gauge calibrated in FSW (feet of seawater). See Section 8.4 Pneumo Readings on Page 29 for details. The system components are:

1. Diver pneumo valve (yellow handle) controls the air supply to the pneumo Fathometer system.
2. Pneumo gauge, dual scale 0-250 FSW/0-76 MSW, mirrored scale, 6 inch, high precision, 0.25% of full scale accuracy.
3. Diver pneumo outlet connections are O₂ (oxygen) type fittings. (37° JIC fitting optional).

6.3 Drawing, Front Panel Air Control

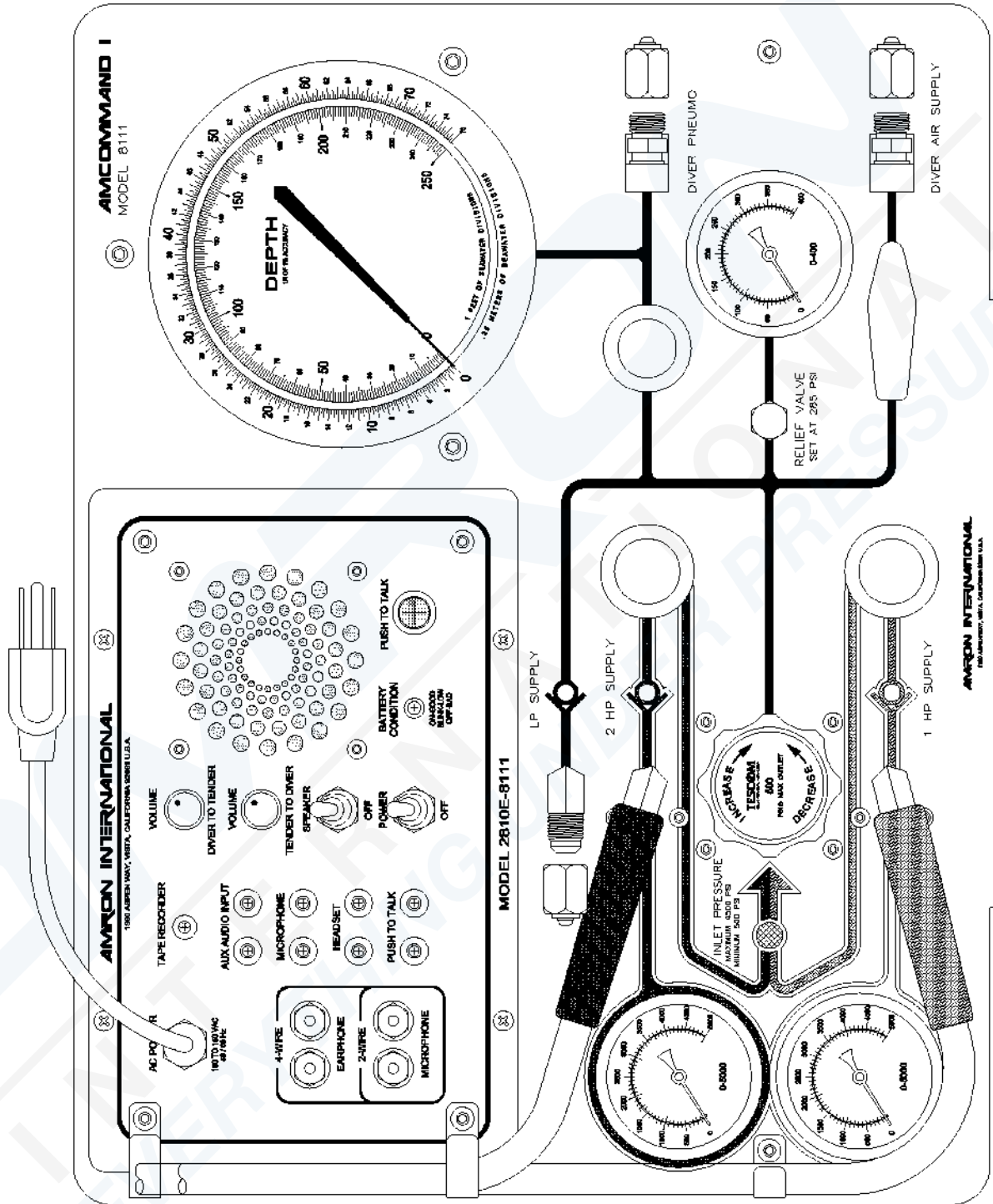

6.4 Communications

Before using the 2810E-8111 Diver Communicator, the operator should be familiar with all the controls and connections. While reading this manual, you will find capitalized words such as PANEL SPEAKER. These words are to remind the reader that additional information can be found in this section of the manual.

6.4.1 Tender Controls (See drawing [6.5](#))

The following controls are located on the front panel of the MODEL NUMBER.

POWER SWITCH - The power on/off control.

SPEAKER SWITCH - This switch allows the tender to turn off the speaker. If the tender is using a headset, it may be necessary to turn off the speaker in order to prevent acoustic feedback.

TENDER TO DIVER VOLUME - This control sets the volume for the diver's earphone including any signal from the AUXILIARY AUDIO INPUT. Rotate this knob clockwise to increase the volume.

PUSH-TO-TALK ALL BUTTON - This button allows the tender to talk to the diver when operating in 2-Wire mode. It is not necessary to use this control in the Full Duplex (4-Wire) mode. When using Full Duplex mode, this control allows the tender to interrupt the diver by forcing the diver into listen only mode.

PANEL SPEAKER - A waterproof, acoustic speaker that allows the tender to monitor communication to the diver and act as a microphone by using the PUSH-TO-TALK BUTTON. The volume level is controlled by the EARPHONE VOLUME control and it can be turned off using the SPEAKER SWITCH.

BATTERY CONDITION INDICATOR – This LED is used by the tender to determine the available battery level. A steady green light means that the battery charge level is greater than 30%. When the battery reaches approximately 30% remaining life, the LED will start blinking at a rate of about once per second. When the battery reaches its end-of-charge, the LED will turn off and the 2810E-8111 will go into shutdown mode to prevent damaging the communicator or rechargeable battery. It is advised that the 2810E-8111 be connected to AC power as soon as possible once the BATTERY CONDITION INDICATOR starts blinking, to recharge the battery, through the internal charger. While there should be enough time to safely complete a normal diving operation, the exact amount of time is dependent on the age and condition of the sealed lead acid battery.

6.4.2 Tender Connections

TENDER HEADSET - This is the dual banana jack (color-coded black) that functions as both an output (earphone) and input (microphone) for the tender as controlled by the **PUSH-TO-TALK BUTTON** and **PUSH-TO-TALK JACK**. Using this connection, the tender can be wired in either 2-Wire or Full Duplex (4-Wire) mode regardless of the mode used for the diver.

To connect the tender in the Full Duplex (4-Wire) mode, connect the earphone (black) banana plug of the headset to this jack and the microphone (red) to the **TENDER MICROPHONE** jack (red) as shown in the wiring diagram in section 8.6. In this mode, the tender does not have to use the **PUSH-TO-TALK BUTTON** to communicate with a diver who is also connected in the Full Duplex (4-Wire) mode. This configuration can be used even if the diver is connected in 2-Wire mode. In that situation, the tender is required to use the **PUSH-TO-TALK BUTTON** or **PUSH-TO-TALK JACK**.

The headset microphone is always active which means that there can be acoustic feedback between the **PANEL SPEAKER** and the microphone if the tender is near the 2810E-8111. To prevent this, the **PANEL SPEAKER** can be turned off using the **SPEAKER SWITCH**. Another option is to move the tender away from the 2810E-8111 by using the Amron Model 2822-28 Walk-and-Talk Module accessory. This allows the tender to communicate while other members of the surface crew listen using the **PANEL SPEAKER**. This module comes with 25 feet (7.6 meters) of cable (custom cable lengths are available).

The tender can also be connected in 2-Wire mode by stacking both the earphone (black) and microphone (red) banana plugs into this jack as shown in the wiring diagram in section 3.5. The diver does not have to be connected in 2-Wire mode if the tender is in 2-Wire mode. In order to talk to the diver, the tender must use either the **PUSH-TO-TALK BUTTON** or **PUSH-TO-TALK JACK**. Since the headset microphone is not active until one of the push-to-talk methods is used, there is no chance for acoustic feedback to occur and surface conversation or noise is not transmitted to diver and the **PANEL SPEAKER** can be left on. This may, for some situations, make for a better overall diving experience. If the tender requires more mobility at the dive site, the Amron Model 2821-28 Remote Push-to-Talk Module can be used to extend the headset cable. It includes a push-to-talk button on a clip-on belt module and comes standard with 25 feet (7.6 meters) of cable (custom cable lengths are available).

The tender may also use the optional Amron Model 2405-28 Push-to-Talk Microphone. This microphone comes with two color-coded banana plugs. The black plug goes into the **TENDER HEADSET** jack and the yellow plug goes in the **PUSH-TO-TALK JACK** as shown in the wiring diagram in section 8.7. To communicate with the diver, the tender presses the button on the side of the microphone. There is no chance of acoustic feedback since the **PANEL SPEAKER** is cut-off when the tender uses the microphone. When using the Push-to-Talk Microphone, the **SPEAKER SWITCH** must be turned on in order to hear the diver.

TENDER MICROPHONE - This is a dual banana jack (color-coded red) that functions as the microphone input from the tender's headset. It is only used if the tender is in Full Duplex (4-Wire) mode.

PUSH-TO-TALK JACK - This is a dual banana jack (color-coded yellow) that allows for remote keying of the push-to-talk function of the 2810E-8111. The difference between using the PUSH-TO-TALK JACK and PUSH-TO-TALK BUTTON is that the button allows the tender to communicate using the PANEL SPEAKER as a microphone. If both are used at the same time, the PANEL SPEAKER is active as a microphone. This allows a crew member to talk to the diver using the PANEL SPEAKER even if the tender is away from the 2810E-8111 using the Remote Push-to-Talk Module in 2-Wire mode.

RECORDER OUTPUT - This is a single RCA Phono jack (color-coded black) that provides a transformer isolated signal of both the diver and tender communications. It is designed to drive the standard line-level inputs of audio or video recorders with input impedances as low as 600 Ohms. The RECORDER OUTPUT will not record the signal from the AUXILIARY AUDIO INPUT.

AUXILIARY AUDIO INPUT - This is a set of two RCA Phone jacks (color-coded red and white) that provides a means to connect an external audio signal for diver entertainment. Although this input will accept a stereo audio source, it will be converted into a monaural signal before going to the diver. This signal is not heard in either the tender headset or via the PANEL SPEAKER. The earphone output of most MP3 players can be connected to this input using an adaptor cable like the Amron Audio Adaptor Cable (Amron Part Number 180-1000-00). This feature will only work if the diver is wired in Full Duplex (4-Wire) mode.

There is no separate volume control provided for the diver entertainment signal. It is up to the audio device to provide a volume control. It is advised at the start of diving operation, and before the external audio device is turned on, that the tender adjust and verify the TENDER TO DIVER VOLUME level is correct and comfortable for the diver. Then starting with the lowest volume, adjust the volume on external device until a comfortable level is achieved. If the tender is connected in the Full Duplex (4-Wire) mode, the volume level should not be so loud as to prevent the diver from hearing the tender. If the tender is connected in the 2-Wire mode, then the entertainment will be cut off whenever the PUSH-TO-TALK BUTTON or PUSH-TO-TALK JACK is used. The PUSH-TO-TALK BUTTON can be used by the tender to cut off the entertainment even if the tender is connected in the Full Duplex (4-Wire) mode.

WARNING!

The AUXILIARY AUDIO INPUT is not electrically isolated from the circuitry of the 2810E-8111. Any external equipment connected to the input should not be AC powered or connected to the AC mains indirectly through any equipment without the proper isolation. Failure to follow this warning may result in electrocution or death of the diver.

EXTERNAL BATTERY JACK - The 2810E-8111 can be powered using an external battery or power supply via the two color coded TIP jacks. The red TIP jack is the positive power input and the black is the negative power input. The input voltage must be between 9 and 18 VDC and must be able to supply a peak current of 3 Amps for proper operation. The following warnings need to be heeded when using the EXTERNAL BATTERY JACK. A minimum wire size of 18 AWG and maximum wire run of 3 feet (1 meter) is recommended.

6.4.3 Diver Connections

DIVER MICROPHONE - This is a dual 5-way binding post jack (color-coded red) that functions as both an output (earphone) and input (microphone) for the diver as controlled by the PUSH-TO-TALK BUTTON and PUSH-TO-TALK JACK. Using this connection, the diver can be wired in either 2-Wire or Full Duplex (4-Wire) mode regardless of the mode used for the diver.

To connect the diver in Full Duplex (4-Wire) mode, connect the diver microphone to this jack and the diver earphone the DIVER EARPHONE jack as shown in the wiring diagram in section 8.7. The diver can use this mode even if the tender is wired in 2-Wire mode.

To connect the diver in 2-Wire mode, connect both the diver microphone and earphone to this jack. If the diver umbilical uses banana plugs, simply stack both plugs into this jack as shown in the wiring diagram in section 8.7. In this mode, the diver microphone will be active and heard on tender headset and/or PANEL SPEAKER unless the PUSH-TO-TALK BUTTON or PUSH-TO-TALK JACK is activated.

DIVER EARPHONE - This is a dual 5-way binding post jack (color-coded black) that functions as the output for the diver's earphone. It is only used when the diver is in Full Duplex (4-Wire) mode.

6.5 Drawing, Front Panel Communicator

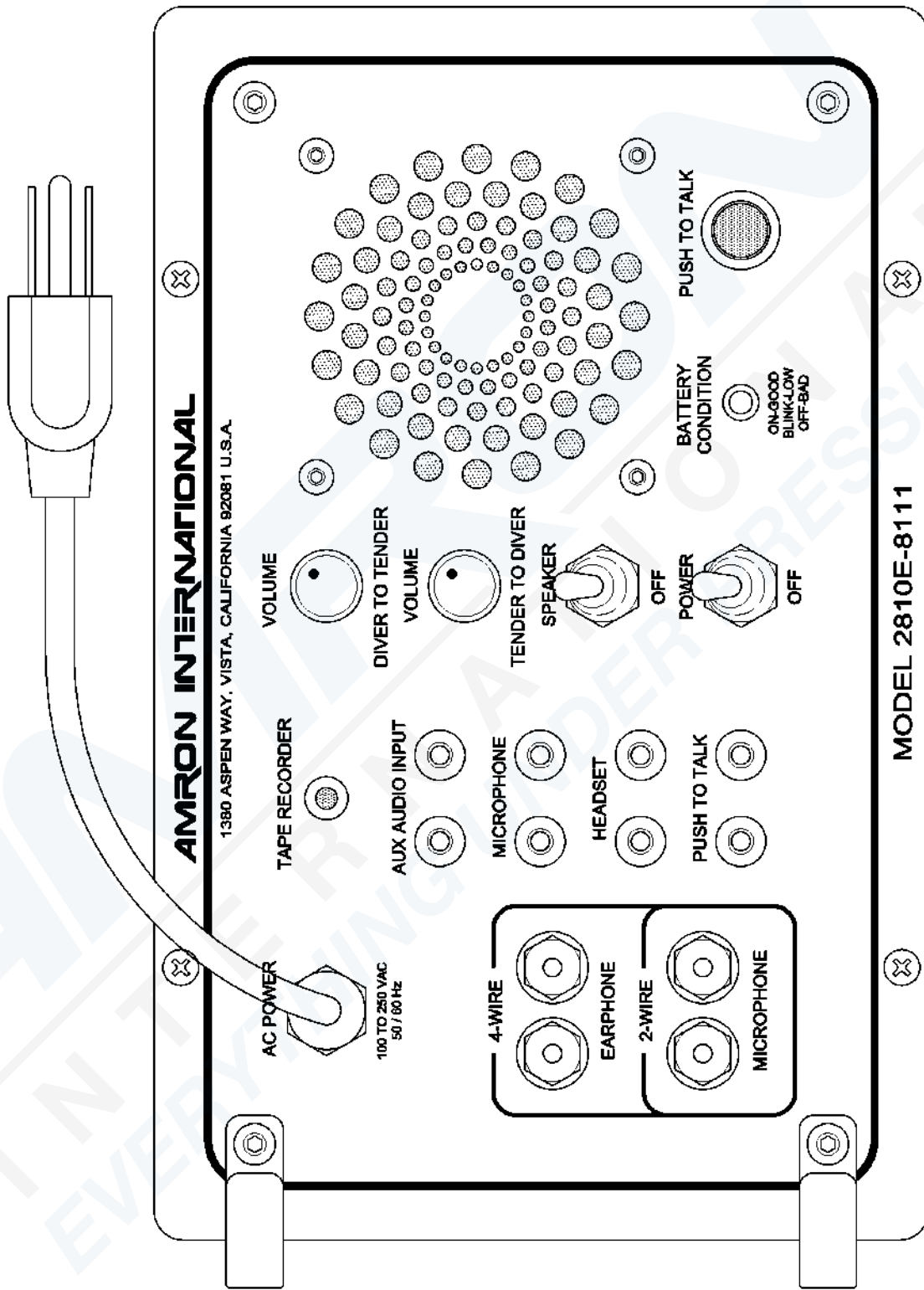

7. PRE-DIVE PROCEDURES

7.1 Pre-Dive Set-Up

1. Place AMCOMMAND I on flat surface that can support the unit. Select a working area which is secure, stable, convenient, and suitable for use during the period of the dive.
2. Open unit and remove both yokes and color coded high pressure hose whips from the storage position. Conduct a visual inspection of unit to insure no damage has occurred during transportation to the job site, or since the last time the unit was used.
3. Attach each yoke to a scuba cylinder by screwing down until finger tight.

Note: be sure the bleeder valve on each yoke is in the closed position. (**Note:** do not turn the cylinder's air on at this time).

4. If available, a low pressure compressor should be used as the primary air supply and scuba cylinders used as a back-up air source.

Note: Low pressure compressors used for breathing air should be specifically designed for diving.

5. All hose whips should be clear of debris and have their open ends taped, capped or plugged when not in use.
6. Flush out low pressure hose whip before connecting to the AMCOMMAND I to prevent debris from entering system.
7. Attach hose whip to LP supply inlet fitting.

Note: When tightening, USE TWO WRENCHES place one wrench on inlet fitting and hold, turn hose fitting with a second wrench making sure not to over tighten.

7.2 Pre-Dive Check Out

1. Be sure both the high pressure valves, pneumo valve, and air supply valves are in the 'off' (closed) position.
2. Regulator should be set to a low pressure, turn knob counter clockwise until the knob stops.
3. Turn the Diver output valves and pneumo valves to 'off' position.
4. With the yoke bleeder valve in closed position, turn on high pressure air at both SCUBA or breathing air cylinders. **Note:** Always open high pressure valves slowly, allow system to fill slowly before opening valves for maximum flow. Check the pressure level of both HP supplies.
5. Turn on 1 HP supply valve by turning counter clockwise four (4) full turns. **Note:** 2 HP supply valve should be in the off position and used as a back-up.

Caution: If both HP valves are opened at the same time, both air supplies will be used simultaneously. This will result in both bottles being empty at the same time. The purpose of the two supplies is to alternate between the two bottles. Use one of the bottles until it reaches 500 PSI, and then switch to the second bottle. With a full bottle on line, you can then replace the first bottle with a full unit.

6. Note the cylinders air pressure by reading the HP supply gauges.
7. Adjust regulator to desired setting by turning knob while monitoring the diver air supply gauge. Clockwise increases the set pressure.

Note: Regulator setting is determined by: required over-bottom pressure for manufacturer's helmet or mask plus the bottom pressure relating to the diver's depth. See section 12.4 for gauge pressure verses depth chart

7.3 Pre-Dive Pneumo Test

The AMCOMMAND I Pneumo section has gauge protectors to protect the pneumo gauges from over pressurization. However it is good operating practice to use a procedure which will not damage the gauges when operating a system without gauge protectors. Using a standard procedure will permit the operator to use a different system without gauge protectors and operate the system correctly.

A Pneumo gauge with a range of 250 FSW/76 MSW has an equivalent full-scale pressure rating of 111.25 PSI. If you exceed this pressure by a significant amount you will cause a permanent change in the calibration of the gauge. If you exceed 111 PSI by 100% you will destroy the gauge.

Procedure for checking the pneumo gauges:

1. Pressurize the LP section of the AMCOMMAND I; reduce the output pressure of the regulator to a pressure less than 100 PSI.
2. Open the diver output valve momentarily to reduce the pressure and check the action of the regulator. Check to see that the output of the regulator stays at less than 100 PSI.
3. Open Pneumo valve slowly, while watching the depth gauge, check that the gauge needle is slowly rising and that air is exhausting through the diver's pneumo connection (or diver's pneumo hose if connected).
4. Close valve; check depth gauge to see that it reads zero. The gauge should be within +/- 10 feet of zero. Zero will be affected by changes in atmospheric pressure and/or changes in altitude. If zero is off by more than 10 feet and there has not been a significant change in either atmospheric pressure or altitude, suspect that the gauge has been subjected to over-pressurization and may have suffered damage. Cross-check the gauge or have the gauge calibrated before using.

5. Seal the output of the pneumo section. This can be done by capping off the pneumo output, or preferable sealing the end of the pneumo hose. Pressurize the pneumo to 200 FSW and close the blow-down valve. This reading should hold, with out a decrease in reading. If the reading decreases you have a leak in the system, correct before proceeding.
6. Cross-checking the pneumo gauge by connecting a known calibrated gauge to the pneumo output. Open the pneumo valve and pressurize the system. Both gauges should have the same reading. If the gauges differ by more than 2%, have the defective gauge calibrated. Gauge calibration should be compared at several points over the range of the gauge, with both increasing and decreasing pressure. As a minimum check the gauges over the range which the gauge will be used.

7.4 Pre-Dive Testing Communications

1. Always test the communications between the AMCOMMAND I and diver before each dive. Connect the diver's umbilical to the diver communicator, and the helmet / hat to the umbilical.
2. Turn power to "ON" position.
3. Set "Tender's Volume" at mid scale. While diver is speaking, adjust to a comfortable level.
4. Set "Diver's Volume" at mid scale. Talk to diver and adjust until diver can hear tender at a comfortable level.
5. Become familiar with the "Push- to -Talk" switch by pushing the switch when talking to the diver. **Note:** If switch is depressed, tender cannot hear diver. Diver cannot hear tender if tender does not actuate the "Push- to -Talk" switch.

7.5 Connecting Diver Umbilical

1. Remove protective caps and attach diver air supply and diver pneumo hose fittings to corresponding outlets. **Note:** When tightening, place one wrench on outlet fitting and one wrench on hose fitting. Tighten hose fitting, making sure not to over tighten.
2. Blow out diver's air supply hose to insure no debris is in the line before connecting to a helmet or mask.
3. Connect the communication cable (surface end) to the two binding posts located on the right side of radio. Wires should be well fastened to the binding posts and not touching each other (bare wire). We strongly recommend the use of dual banana plugs attached to the top side end of the umbilical. This ensures a good connection and reduces the possibility of shorts and/or intermittent connections. Attach diver's end to helmet or mask.

4. Test the operation of the system.

7.6 Low Pressure Supply

Test LP supply with low pressure compressor.

Note: Adjust diver air supply pressure at compressor. The AMCOMMAND's LP supply system bypasses the regulator, therefore, cannot control air pressure entering system or the pressure to the diver.

8. OPERATING PROCEDURES

8.1 Low Pressure Breathing Air (Primary Supply)

Low Pressure Compressor (Primary supply), High Pressure (Backup). In this mode of operation the diver's breathing air is being supplied by an LP compressor, the HP Supply is use as a back-up supply. Having the HP supply as a backup does not eliminate the requirement for a bailout source of air.

In the event the LP air source fails, it is a simple matter to switch over to HP air. Turn "ON" the HP source by opening the HP-1 valve. Check the diver's air supply pressure.

8.2 High Pressure Breathing Air (Primary Supply)

In this mode of operation, the diver's breathing air is being supplied by via high pressure breathing air source. This could include SCUBA tanks (singles or twins), high pressure storage cylinders, or a bank of high-pressure storage cylinders.

CAUTION!

Maximum input pressure limit of 3000 PSI when using standard CGA850 yokes.

Maximum input pressure limit of 4500 PSI when using optional 300 Bar DIN adapters.

The High Pressure breathing system is designed to allow the rotation of bottles as they are consumed. Operate the system using a single bottle until the bottle pressure has dropped to approximately 500 PSI, then switch to the next bottle. Repeat this procedure alternating between HP-1 and HP-2, changing bottles as they are used. The HP input system has check valves, which prevent back-flow between the bottles. This facilitates switching between bottles.

Example:

If you have two bottles connected to the system and you are using bottle HP-1, bottle HP-2 is "OFF", when HP-1 reaches 500 PSI, you may switch to HP-2 by opening the valve for HP-2. The system will draw air from the higher of the two sources, HP-2. You can then turn HP-1 "OFF", and change the bottle connected to source HP-1. This procedure ensures an uninterrupted supply of air to the diver.

After turning HP-1 off, turn the bottle valve off, open bleed-valve on the yoke and bleed the pressure. Release the yoke and replace the empty bottle with a full bottle. Close the bleed-valve and turn SCUBA cylinder on and verify the bottle is full.

Another method of changing bottles is to leave both valves on the system in the “ON” position. Use the SCUBA bottle valves as the ON/OFF control for selecting which bottle is in use. This reduces the number of valves, which must be open and closed for each change of bottles. If you use this procedure, you should periodically open the new bottle and check the gauge to ensure the bottle is full, then close bottle to prevent the system from using air from both bottles at the same time.

1. When planning your dive you must take into consideration the amount of time a given bottle will last and the number of bottle changes, which will be necessary during the dive. There are two options that can be used to accommodate dives that will have a high consumption of air.
2. A) Use twin tanks instead of singles. B) Use a high volume cylinder (250 - 300 cubic feet) of breathing air; these can generally be rented from a welding gas supplier, or supplier of industrial gases. Make sure you specify breathing air, and request certification. These cylinders can be also be manifolded quite easily. Generally the charge for rental is very competitive in cost and usually includes delivery to the job site.

Note: When using high-pressure cylinders, care must be exercised in the handling, transport and storage of it. Make sure all personnel involved are instructed in the proper procedures. If you have any questions regarding the proper procedures contact your supplier.

8.3 Pre-Operation Checklist

1. Diver dressed and ready except helmet / hat
2. Diver’s umbilical organized
3. LP Compressor running and at pressure
4. LP Alarm in “ON” position
5. HP source connected and ready, HP-1 and HP-2 valves “OFF”
6. Zero Pneumo Gauge
7. Diver air ON, purge diver Helmet / hat
8. Diver dons helmet / hat
9. Diver communicator ON, Comm check
10. Diver air check
11. Diver enters water
12. Record the starting time of the dive

During the dive, the tender shall maintain voice communication with the diver at all times. Tender shall monitor diver’s air pressure and breathing rate.

8.4 Pneumo Readings

During the dive, the tender shall monitor the diver's depth, recording the depth and time at depth. The procedure for measuring depth is as follows:

1. Advise the diver that a pneumo reading is to be taken.
2. The diver will place the end of the pneumo hose at the point at which the measurement shall be taken. Diver will advise the tender he is ready for the pneumo reading.
3. Slowly open the pneumo valve corresponding to the diver whose depth is being measured. The pneumo gauge reading will increase and stabilize at a value greater than the depth of the diver. The value will depend upon the flow rate, and pressure drop over the length of the pneumo hose. The diver will advise the tender of bubbles coming from the end of the hose.
4. Close the pneumo valve, the reading will to decrease to the value of the diver's depth. Once the reading has stabilized, this is the depth at the end of the pneumo hose.

Note: Pneumo readings can be used for several purposes i.e., measuring the diver's depth, depth to a particular point under water, vertical distance from one underwater object to another. The accuracy of the measurement is plus or minus 0.625 feet of seawater, (+/- 7.5 inches). This represents an overall accuracy of +/- 1/4 of 1% of the full-scale value of the depth gauge. To maintain this accuracy the gauges must be calibrated every 6 months.

When using the pneumo system to measure the diver's depth for use in determining decompression requirements, please note the following:

8.4.1 Definitions of terms, PAR 7.1

DEPTH - When used to indicate the depth of a dive, it means the maximum depth attained by any part of the diver during the dive, measured in feet of seawater.

8.4.2 Selection of decompression Schedule, PAR 7.2.3

- (A) Always select the schedule depth to be equal to or the next depth greater than the actual depth to which the dive was conducted, and
- (B) Always select the schedule bottom time to be equal to or the next longer bottom time than the actual bottom time of the dive.

8.4.3 Rules during ascent, PAR 7.4.1

Decompression Stop Depth - The diver's chest should be located as close as possible to the stop depth.

The above information is quoted from the U.S. NAVY DIVING MANUAL, Chapter 7, Air Decompression.

8.5 Diver Communications – Power on Battery Check 2810E-8111

Turn all the volume controls to minimum and turn on the POWER SWITCH. The state of the battery is shown on the BATTERY CONDITION INDICATOR as follows:

- STEADY GREEN - the battery is good and has more than 30% remaining life
- BLINKING GREEN - the battery is low and has less than 30% remaining life
- OFF or NO LIGHT - the battery is depleted and needs to be changed/recharged before use

The BLINKING GREEN light provides a warning that the battery is low and should be recharged or replaced if necessary before starting the dive operation. When the indicator starts BLINKING GREEN during dive operations, it means that there is, depending on age of the battery and the ambient temperature, approximately 24 hours of remaining life for the 2810E-8111. This should be sufficient time to safely complete dive operations. A battery that has not been used for a long period of time will exhibit a higher voltage than the actual charge state. This is known as surface charge and will quickly dissipate once the unit is turned on. It is recommended that the unit be left on for 5 minutes before relying on the BATTERY CONDITION INDICATOR.

To charge the batteries after using, connect the 2810E-8111 to a 110/220 VAC outlet; confirm the presence of AC power via the indicator on the front of the panel.

When operating from 220 VAC, the 2810E-8111 will automatically sense the input voltage and adjust appropriately. The customer will have to use a power cord approved for the country of use. It may be purchased locally or from AMRON.

It is recommended the unit be placed on charge, and left on charge, until the unit is to be used again. This ensures the unit will always be ready to use, and the batteries are fully charged. The charger is designed not to damage the batteries when left on continuous charge. Full charge will occur in roughly 10 hours (depending on the age of the battery and surrounding temperature). If the unit is in constant use, daily, it is recommended the unit be left on charge, during the weekend, to top off the batteries. Batteries must be recharged periodically, a minimum of at least once every six months.

Operating time for the rechargeable battery should be on the order of 85 hours, depending upon the age of the batteries. The Gel Cell battery has a life of 300 cycles, or 3 years. Gel Cell batteries do not have memory, therefore they can be topped up (placed on charge) at any time.

NOTE: Do not continue to operate rechargeable batteries below the low battery condition or permanent damage will occur. When the battery reaches approximately 30% remaining life, the LED will start blinking at a rate of about once per second.

When the battery reaches its end-of-charge, the LED will turn off and the 2810E-8111 will go into shutdown mode to prevent damaging the communicator or rechargeable battery.

The Model 2810E-8111 has the ability to operate in either 2-Wire or Full Duplex (4-Wire). Both the diver and tender can be connected in either mode and a combination of modes can be used. For example, the diver can be connected in Full Duplex (4-Wire) mode to take advantage of the new entertainment feature while the tender is wired in 2-Wire mode. If either the diver or the tender is wired in 2-Wire mode, the tender must use a push-to-talk, either the PUSH-TO-TALK BUTTON or PUSH-TO-TALK JACK, when talking to the diver.

2-Wire communication is defined as a single communication path; normally the diver is the priority signal path, and tender listens to diver. Signal reversing is accomplished by pushing the PUSH-TO-TALK BUTTON, diver hears tender. Often times a 4-conductor communication cable is used with 2 wires tied together as a pair for redundancy, this is still a 2-Wire system. Since only one person can talk at a time, there is a level of discipline that goes with using 2-Wire mode in order to obtain clear communication. One advantage of 2-Wire is that the tender's microphone is not active unless one of the two push-to-talk controls, PUSH-TO-TALK BUTTON or PUSH-TO-TALK JACK, are active. This eliminates any possible acoustic feedback between the tender's microphone and the PANEL SPEAKER. It also prevents noise from the surface reaching the diver and allows the tender to communicate with other members of the surface crew without involving the diver. If the diver is connected in 2-Wire mode, the AUDIO AUXILIARY INPUT cannot be used to deliver entertainment to the diver.

Full Duplex (4-Wire) communication is defined as a dual communication path, a signal path (a pair of wires) for up-link and a signal path (a pair of wires) for down link. A common example of Full Duplex communication is the telephone. Full Duplex (4-Wire) has the advantage of natural communication without having to use the PUSH-TO-TALK BUTTON. This keeps the tender's hands free to perform other tasks. It does not require the same level of discipline to achieve clear communications that 2-Wire does. It has the advantage that neither the diver nor the tender are cut off when the other is talking. Because the diver's microphone is not connected in parallel with the earphone, the diver is louder and potentially clearer in Full Duplex (4-Wire) mode. More information on this mode can be found later in this section, FULL DUPLEX (4-WIRE) - WHAT, WHY AND HOW.

8.6 2-Wire Operation

1. To connect the diver in 2-Wire mode, connect the communication umbilical wires to the DIVER MICROPHONE binding post jack on the 2810E-8111 as shown in the wiring drawing in section 8.7. If the umbilical uses a banana plug, simply insert the plug into the binding post jack. Verify that it is firmly and completely seated. This may require that the external plastic nut be tightened down. If the umbilical uses bare wires, loosen the external plastic nut of the binding post jack. Either insert the bare end of the wire into the hole in the metal shaft of the binding post or firmly wrap the wire around the shaft.

Tighten the nut until the bare wire is firmly fastened by the nut. The nut should not be fastened on the insulation of the wire nor should any of the bare wires touch.

2. The tender can operate in 2-Wire without a headset or push-to-talk microphone by using the PANEL SPEAKER as both a speaker and microphone. When the tender wants to talk to the diver, he presses the PUSH-TO-TALK BUTTON on the front panel and speaks clearly into the PANEL SPEAKER at a distance of between 4 to 8 inches (10 to 20 cm). When done speaking, the tender releases the PUSH-TO-TALK BUTTON to allow the diver to communicate.

When the tender uses a headset or push-to-talk microphone, follow the connection instruction in section 6.5 and in the wiring diagram in sections 8.8 and 8.9. When using the Amron Model 2405-28 Push-to-Talk Microphone, the tender presses the push-to-talk button on the side of the microphone and speaks clearly at a distance of between 1 and 2 inches (25 to 51 mm). When done speaking, the tender releases the push-to-talk button to allow the diver to communicate.

Whenever either the diver or the tender are connected in 2-Wire, the tender must use one of the push-to-talk methods when talking to the diver.

8.7 Diagram, 2-Wire Set-Up Instructions

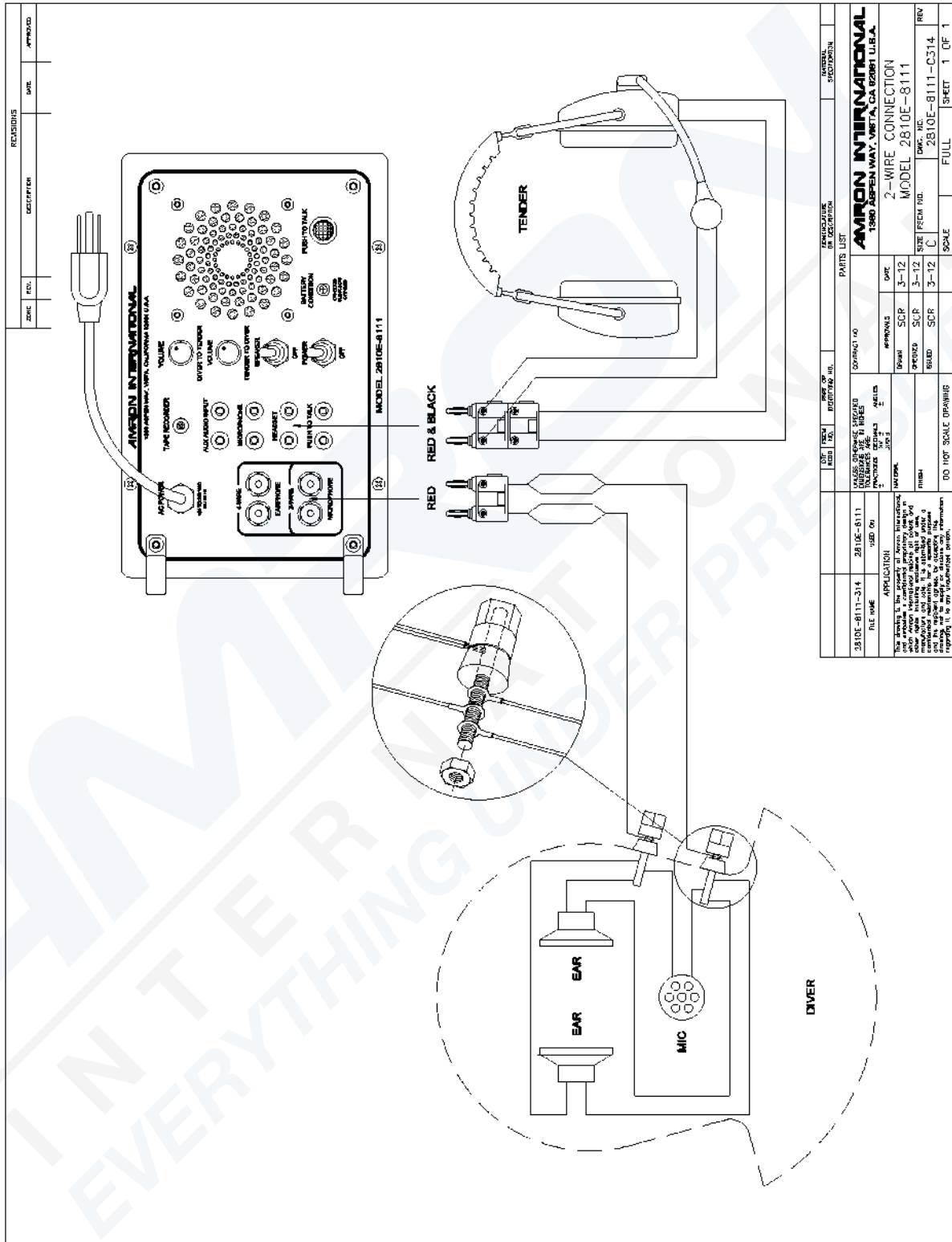

| DATE | REV. | DESCRIPTION | DATE | APPROVED |
|------|------|-------------|------|----------|
| | | | | |

| REV. | DESCRIPTION | DATE | BY | APP. |
|----------------|-------------|---------|----|------|
| 3810E-8111-014 | 2810E-8111 | 1988 08 | | |
| 3810E-8111-015 | 2810E-8111 | 1988 08 | | |
| 3810E-8111-016 | 2810E-8111 | 1988 08 | | |
| 3810E-8111-017 | 2810E-8111 | 1988 08 | | |
| 3810E-8111-018 | 2810E-8111 | 1988 08 | | |
| 3810E-8111-019 | 2810E-8111 | 1988 08 | | |
| 3810E-8111-020 | 2810E-8111 | 1988 08 | | |
| 3810E-8111-021 | 2810E-8111 | 1988 08 | | |
| 3810E-8111-022 | 2810E-8111 | 1988 08 | | |
| 3810E-8111-023 | 2810E-8111 | 1988 08 | | |
| 3810E-8111-024 | 2810E-8111 | 1988 08 | | |
| 3810E-8111-025 | 2810E-8111 | 1988 08 | | |
| 3810E-8111-026 | 2810E-8111 | 1988 08 | | |
| 3810E-8111-027 | 2810E-8111 | 1988 08 | | |
| 3810E-8111-028 | 2810E-8111 | 1988 08 | | |
| 3810E-8111-029 | 2810E-8111 | 1988 08 | | |
| 3810E-8111-030 | 2810E-8111 | 1988 08 | | |
| 3810E-8111-031 | 2810E-8111 | 1988 08 | | |
| 3810E-8111-032 | 2810E-8111 | 1988 08 | | |
| 3810E-8111-033 | 2810E-8111 | 1988 08 | | |
| 3810E-8111-034 | 2810E-8111 | 1988 08 | | |
| 3810E-8111-035 | 2810E-8111 | 1988 08 | | |
| 3810E-8111-036 | 2810E-8111 | 1988 08 | | |
| 3810E-8111-037 | 2810E-8111 | 1988 08 | | |
| 3810E-8111-038 | 2810E-8111 | 1988 08 | | |
| 3810E-8111-039 | 2810E-8111 | 1988 08 | | |
| 3810E-8111-040 | 2810E-8111 | 1988 08 | | |
| 3810E-8111-041 | 2810E-8111 | 1988 08 | | |
| 3810E-8111-042 | 2810E-8111 | 1988 08 | | |
| 3810E-8111-043 | 2810E-8111 | 1988 08 | | |
| 3810E-8111-044 | 2810E-8111 | 1988 08 | | |
| 3810E-8111-045 | 2810E-8111 | 1988 08 | | |
| 3810E-8111-046 | 2810E-8111 | 1988 08 | | |
| 3810E-8111-047 | 2810E-8111 | 1988 08 | | |
| 3810E-8111-048 | 2810E-8111 | 1988 08 | | |
| 3810E-8111-049 | 2810E-8111 | 1988 08 | | |
| 3810E-8111-050 | 2810E-8111 | 1988 08 | | |
| 3810E-8111-051 | 2810E-8111 | 1988 08 | | |
| 3810E-8111-052 | 2810E-8111 | 1988 08 | | |
| 3810E-8111-053 | 2810E-8111 | 1988 08 | | |
| 3810E-8111-054 | 2810E-8111 | 1988 08 | | |
| 3810E-8111-055 | 2810E-8111 | 1988 08 | | |
| 3810E-8111-056 | 2810E-8111 | 1988 08 | | |
| 3810E-8111-057 | 2810E-8111 | 1988 08 | | |
| 3810E-8111-058 | 2810E-8111 | 1988 08 | | |
| 3810E-8111-059 | 2810E-8111 | 1988 08 | | |
| 3810E-8111-060 | 2810E-8111 | 1988 08 | | |
| 3810E-8111-061 | 2810E-8111 | 1988 08 | | |
| 3810E-8111-062 | 2810E-8111 | 1988 08 | | |
| 3810E-8111-063 | 2810E-8111 | 1988 08 | | |
| 3810E-8111-064 | 2810E-8111 | 1988 08 | | |
| 3810E-8111-065 | 2810E-8111 | 1988 08 | | |
| 3810E-8111-066 | 2810E-8111 | 1988 08 | | |
| 3810E-8111-067 | 2810E-8111 | 1988 08 | | |
| 3810E-8111-068 | 2810E-8111 | 1988 08 | | |
| 3810E-8111-069 | 2810E-8111 | 1988 08 | | |
| 3810E-8111-070 | 2810E-8111 | 1988 08 | | |
| 3810E-8111-071 | 2810E-8111 | 1988 08 | | |
| 3810E-8111-072 | 2810E-8111 | 1988 08 | | |
| 3810E-8111-073 | 2810E-8111 | 1988 08 | | |
| 3810E-8111-074 | 2810E-8111 | 1988 08 | | |
| 3810E-8111-075 | 2810E-8111 | 1988 08 | | |
| 3810E-8111-076 | 2810E-8111 | 1988 08 | | |
| 3810E-8111-077 | 2810E-8111 | 1988 08 | | |
| 3810E-8111-078 | 2810E-8111 | 1988 08 | | |
| 3810E-8111-079 | 2810E-8111 | 1988 08 | | |
| 3810E-8111-080 | 2810E-8111 | 1988 08 | | |
| 3810E-8111-081 | 2810E-8111 | 1988 08 | | |
| 3810E-8111-082 | 2810E-8111 | 1988 08 | | |
| 3810E-8111-083 | 2810E-8111 | 1988 08 | | |
| 3810E-8111-084 | 2810E-8111 | 1988 08 | | |
| 3810E-8111-085 | 2810E-8111 | 1988 08 | | |
| 3810E-8111-086 | 2810E-8111 | 1988 08 | | |
| 3810E-8111-087 | 2810E-8111 | 1988 08 | | |
| 3810E-8111-088 | 2810E-8111 | 1988 08 | | |
| 3810E-8111-089 | 2810E-8111 | 1988 08 | | |
| 3810E-8111-090 | 2810E-8111 | 1988 08 | | |
| 3810E-8111-091 | 2810E-8111 | 1988 08 | | |
| 3810E-8111-092 | 2810E-8111 | 1988 08 | | |
| 3810E-8111-093 | 2810E-8111 | 1988 08 | | |
| 3810E-8111-094 | 2810E-8111 | 1988 08 | | |
| 3810E-8111-095 | 2810E-8111 | 1988 08 | | |
| 3810E-8111-096 | 2810E-8111 | 1988 08 | | |
| 3810E-8111-097 | 2810E-8111 | 1988 08 | | |
| 3810E-8111-098 | 2810E-8111 | 1988 08 | | |
| 3810E-8111-099 | 2810E-8111 | 1988 08 | | |
| 3810E-8111-100 | 2810E-8111 | 1988 08 | | |

8.8 FULL DUPLEX (4-Wire) Operation

Refer to diagram 8.9

1. Connect the two wires from the diver's microphone to the 'Microphone (Input) Diver'
2. Connect the two wires from diver's earphones to the 'Earphone (Inputs) Diver 1'.
3. Connect tender headset earphones (black dual banana plug) to headset (input).
4. Connect headset microphone (red dual banana plug) to tender microphone.
5. Turn speaker off to avoid acoustic feedback.
6. Operation with speaker is possible by extending tender's headset away from the speaker. Use AMRON Model 2822-28 headset extension cable (25 foot).

8.8.1 Volume Controls

Set all volume controls at mid-scale. Tender should don headset and talk to himself. If adjustments are required, increase or decrease volume (controls). This will establish a system volume level.

8.8.2 Tender Volume Controls

- A. Diver To Tender - Use as a master control.
- B. Tender to Diver - Use as a master control.

If conditions change as a group, the tender volume controls can be used as master volume control.

8.10 Full Duplex (4-Wire) - What, Why and How

Amron has designed the AMCOM Full Duplex (4-WIRE) mode from the ground up, taking advantage of state-of-the-art electronics technology to provide a superior hard-wire communication experience. Full Duplex (4-Wire) mode has the following advantages:

- Up to 285% more signal strength from the diver microphone over the 2-Wire mode using standard 8-Ohm microphones.
- No push-to-talk required leaving the tender's hands free for other tasks.
- The diver and tender can hear themselves talk providing a more natural communication experience.

These advantages produce superior communications and the system is easier to operate by eliminating the need for using a push-to-talk switch. Another advantage is that the system is easy to troubleshoot. In fact it is easier to troubleshoot than 2-Wire system once you understand what is happening. Full Duplex (4-Wire) mode pays off in better communications, something that many of our competitors have yet to achieve. Better communications means higher diver production, safer dive conditions and less down time.

What are 2-Wire and 4-Wire Modes?

Now that we have made these claims, allow us to explain why and how. First, let's define some basic industry terms so that we can all start from the same point.

2-Wire Mode

2-Wire mode is the most commonly used communication mode in the commercial diving industry. Technically it is defined as a single communication path using a minimum of 2 wires in a communication cable. Being a single path, there can only be one talker at a time. Commonly the diver has the priority and the tender listens as the diver talks. In order for the tender to talk to the diver, this communication path has to be reversed. This is done by the tender pressing a push-to-talk switch. This switch activates a set of relays that switch the diver connection to the output side of an audio power amplifier and the tender connection to the input side. This allows the tender to talk while the diver listens.

Most diver communication cables, such as the "Army surplus Comm-Cable," have four wires. These four wires are often separated into two sets of twisted-wire pairs. In many diving operations, these two sets of twisted-pairs are connected in parallel for redundancy. A breakage in a single wire in the cable does not cause a loss of communication, as each wire has a parallel wire to take over. This arrangement is still a 2-Wire mode even though 4 wires are being used.

4-Wire Mode

4-Wire mode uses two communication paths: an uplink from the diver to the tender and a downlink from the tender to the diver. This allows voice communications to go in both directions at the same time. An example of this type of communication system is the telephone. Another example is called Round Robin communications. Amron's Full Duplex (4-Wire) is not the same as Round Robin.

What is Full Duplex (4-Wire)?

It is a 4-Wire dual communication path system that uses special audio amplifiers on the microphone and earphone connection to eliminate the issues associated with Round Robin systems. It allows everyone on the communicator to talk to each other just as if they were on a telephone.

Why are Special Amplifiers Needed?

When developing a 4-Wire communication system, the biggest problem facing the designer is oscillation caused by feedback. This can occur in two ways. The most common is acoustic feedback, also called the Larsen effect, which occurs when the microphone picks up the sound from the speaker and feeds it back into the amplifier. This signal is amplified and sent out the speaker at a higher level. Given the right conditions, this process repeats until the amplifier reaches maximum signal level. The result is usually a high pitch, howling sound commonly heard in public address systems when the volume is turned up too high.

The solution for acoustic feedback is to turn down the amplifier volume and to isolate the speaker from the microphone. In a dive helmet, the diver's head makes a good acoustic isolator. On the surface, a tender using a headset may get some acoustic feedback via the PANEL SPEAKER. The solution is to put some distance between the tender and the PANEL SPEAKER by using the Amron Model 2822-28 Walk-and-Talk Module accessory. Alternatively, the PANEL SPEAKER can be turned off using the SPEAKER SWITCH located on the front panel.

There exists a second, more difficult to avoid feedback path that can also cause oscillation. In 4-Wire mode, there are two sets of wire pairs. One pair carries the signal from the diver microphone to the communicator microphone input. This is an extremely low level signal, typically in the range of about 1mVRMS. The second carries the output signal from the communicator power amplifier to the diver's earphone. This signal can be as high as 4VRMS. The earphone signal is typically about 1000 times greater than the microphone signal and can be as much as 4000 times greater. If the signal on the earphone wire pair were to couple to the microphone wire pair, the result would be a feedback path that can lead to oscillation. To prevent such coupling, the dive cables are constructed using two individual twisted wire pairs and in high quality cables, such as Amron's CC1 communication cable, each pair can be shielded to provide additional protection. Shielding does decrease the amount of coupling between the wire pairs but without special amplifiers, the full capability of using twisted wire pairs is lost.

Amron Diver Communicators are designed with a special balanced circuit, differential input and output amplifiers. In a balanced circuit, each wire in the twisted pair carries an equal and opposite signal. Each wire generates an electromagnetic field that is in opposition with the field of other wire. The net result is that strength of the radiated electromagnetic field is significantly reduced if not totally eliminated. In addition, any external fields, either from the other wire pair or an external noise source, will be coupled to both wires equally creating a common-mode signal. The differential microphone amplifier in Amron Diver Communicators cancels the common-mode signal while amplifying the signal from the microphone. Communicators without both differential input and output amplifiers cannot match the performance of Amron Diving Communicators. This is an extreme simplification of the common-mode coupling effect and common-mode signal rejection but shows the power of Amron's Full Duplex (4-Wire) mode of operation.

Isn't Round Robin The Same Thing?

In Round Robin communication systems, each diver is connected using a 4-Wire cable like the Amron Full Duplex (4-Wire) mode. This is where the similarities end. In Round Robin systems all the microphones are connected together in parallel and connected to the microphone input of the communicator. All the earphones are also connected in parallel and connected to the earphone output of the communicator. Each microphone is loaded by all the other microphones in the system causing lower output. In a two diver setup where the diver microphones have a typical impedance of 8 Ohms and the tender's microphone has an impedance of 150 Ohm, the diver microphone output level will be reduced by about 50% while the tender's microphone is attenuated by out 95%. On the earphone side, the diver earphones commonly have an impedance of 8 Ohms while the typical tender earphone impedance is around 175 Ohms. These two factors combine to create a serious volume imbalance which requires higher volume settings resulting in more noise and less system stability.

Why Full Duplex (4-Wire)?

Amron Diver Communicator uses an independent microphone amplifier for each diver circuit as well as for the tender. This allows Amron Diver Communicators to use the power of common-mode rejection to cancel any coupled noise for each microphone as well as providing less loading of the microphone than in 2-Wire mode. In 2-Wire mode, the diver microphone is wired in parallel with the diver earphones. Assuming that the impedance of the microphone is the same as the earphones, the signal from the microphone is attenuated by 65%. By separating the microphone from the earphones, the output signal from the microphone increases by 285%. With more signal, the volume level can be decreased resulting in less noise and improved system stability for a significant improvement in overall clarity.

8.11 How Do You Use Full Duplex (4-Wire)

In order to use Amron's Full Duplex (4-Wire) mode, you need the following items:

1. An AMCOM series diver communicator
2. A good quality dive communication cable with four wires (two twisted wire pairs) like Amron's CC1
3. A dive hat/helmet with connection for 4 wires such as a Marsh Marine connector
4. To connect the system together, refer to appropriate section of the operating manual for AMCOM diver communicator. In general it involves three steps (using the Amron CC1 cable):
5. Install male Marsh-Marine 4-pin connector in hat/helmet. Attach black and white wires to binding post and both speakers. Attach red and green wires to leads from microphone. It doesn't matter which color goes to which lead. Use 8-32 x 1/4 SS screw and nuts, cover each with tape or shrink tubing. You are now finished with the diving hat/helmet.
6. Install 4-pin female Marsh-Marine connector on diver's end of communication cable. Connect red and green wires to the light colored pair of communication cable wires; black and white wires to black pair of communication-cable wires. You are now finished with this step.
7. Install black dual banana plug to black pair of wires on tender end of diver communication-cable and attach red dual banana plug to lighter color pair of wires. If you don't have red dual banana plugs, red tape will serve to identify that pair as the microphone circuit. **YOU ARE FINISHED!**

To setup and check-out the communication link:

1. Attach hat/helmet to umbilical.
2. Attach communication cable to AMCOM diver communicator. Connect the red banana plug to DIVER MICROPHONE (red) jack and the black banana plug to DIVER EARPHONE (black) jack.
3. Set the volume controls to mid-range on the communicator. Turn on the communicator. There may be some acoustic feedback, if that occurs then reduce the volume until it feedback stops.
4. Don the hat/helmet and start talking. You should hear yourself in earphones. Adjust the volume as necessary for clear communications.

To revert back to 2-Wire mode, simply remove black banana plug from DIVER EARPHONE (black) jack and plug it on top of DIVER MICROPHONE (red) plug.

Things to keep in mind when using Amron's AMCOM diver communicators:

With the AMCOM diver communicators you can mix 2-Wire and Full Duplex (4-Wire) modes of operation. For example, the diver can operate on Full Duplex (4-Wire) mode while the tender operates in 2-Wire mode. The tender can use the panel speaker to listen to the diver and talk to the diver by pressing the push-to-talk button and using the panel speaker as a microphone.

When using AMCOM diver communicators with multiple diver capacity, each diver can be wired in either 2-Wire or Full Duplex (4-Wire) mode. All divers do not have to operate in the same mode.

The push-to-talk button overrides the diver conversation by forcing all divers into listen only mode. This occurs whether the diver is wired in 2-Wire or Full Duplex (4-Wire) mode.

8.13 To Operate and/or Check Out FULL DUPLEX

1. Attach hat to umbilical.
2. Attach common-cable to AMCOM I, red banana plug to Diver 1 mic, black banana plug to Diver 1 earphone.
3. Don hat and talk to yourself. If you hear your voice over the earphones, the system is working correctly.

To revert back to 2-wire, remove black banana plug from earphone jacks (AMCOM I) and plug into top of mic banana plug (red).

To recap, we now have a system where Diver 1's microphone is connected to Diver 1 microphone input of the AMCOM I. Diver 1's earphone is connected to the earphone for Diver 1. All features such as diver push-to-talk switch and independent volume controls of the AMCOM I remain intact. Tender uses a headset that is plugged into the tender mic and headset jacks. Note: The PTT switch over-rides diver conversations (see operating guide for details).

8.14 Battery Replacement, Part No. 2890-05

1. Remove all AC power.
2. Turn off unit.
3. Disconnect all cables.
4. Move hoses so that they will not interfere with the removal of the 2810E-8111 from the 8111.
5. Remove 4 ea. pan head Phillips screws: 2 ea. on each side of "AMRON INTERNATIONAL" & 2 ea. on each side of "MODEL 2810E-8111".
6. Lift the 2810E-8111 out of air control.
7. Remove 4 ea. 8-32x1/2 pan head Phillips screws: 2 ea. from both sides of radio chassis.
8. Tilt front panel to side of chassis.
9. Remove 2 ea. screws from side of chassis that secures battery bracket.
10. Disconnect the two slide terminals from battery.
11. Lift out battery.
12. Replace with new battery.
13. Connect the two slide terminals to battery, RED wire to Positive, BLACK wire to Negative.
14. Re-install battery bracket and 2 ea. screws.
15. Permanently tighten screws.
16. Place panel on top of chassis, being careful not to pinch or damage any wires.
17. Install 4 ea. screws on side of chassis and tighten.
18. Install radio into cutout on air control panel.
19. Install and tighten 4 ea. screws to secure radio to air control panel.
20. Return hoses to their normal positions.
21. Perform Power On - Battery Check.
22. Plug 2810E-8111 into AC power and allow battery to charge for approximately 10 hours (depending on the battery age and surrounding temperature).

9. THEORY OF OPERATION

This section is divided into two parts, the first addresses mechanical operations and the second section addresses electronics operations. Refer to the functional block diagram while reading this section.

9.1 Mechanical

1. HP-1 and HP-2, high-pressure input, has a maximum input pressure limit of 3000 PSI when using standard CGA850 SCUBA yokes with bleed valves and color coded hose protectors. Installing the optional 300 Bar DIN Adapter (Amron Part No. HAS-300D) will increase the units maximum input pressure limit to 4500 PSI. Simply remove CGA850 yoke nut and yoke from bleeder body, screw on the 300 Bar DIN adapter and tighten with a wrench. The SCUBA yokes can also be removed for connection directly to a high-pressure bank with a maximum pressure limit of 4500 PSI. The hose fitting is 1/4 inch 37° flare, female swivel.
2. HP gauges, 0-5000 PSI, 1-1/2 % of full-scale accuracy.
3. HP valves, shut-off type, four turns opens to full flow, S/S stem with KEL-F seat for positive shut off, and Viton O-rings.
4. HP check valves, 1/3 PSI cracking pressure.
5. HP filter, inline 50-micron filter element.
6. HP regulator(s), self-contained, direct acting, spring loaded, diaphragm operated pressure-reducing regulator. Control pressures are obtained by adjusting the control knob. Pressure INCREASES are made by a clockwise rotation while pressure DECREASES are made by a counter-clockwise rotation.

Note: Regulator is a non-venting design and adjustments to decrease the set pressure will not occur unless there is flow through the regulator. If the diver is not on, line adjustment can be made by opening the pneumo valve slightly while adjusting the regulator. All final adjustments should be made in the clockwise direction in order to insure the most accurate set point.

7. When operating in cold weather (40° to 45° F and below), regulator icing may occur. This is caused by moisture condensing and freezing, this can and will cause blockage in the regulator. Increasing the pressure will temporally clear the blockage by lifting the valve seat to allow the ice to blow through. If this happens terminate the dive immediately. The following information provides a guide to the causes and procedures that can reduce the possibility of icing.

The cause of icing is moisture in the breathing air combined with a cold temperature, and high flow rates. Cold air containing moisture is particularly prone to icing. First, air that is cold will support less moisture before condensing occurs. Second, the colder the air is the closer it is to the freezing

point. Third, when air passes an expansion point (the regulator control valve) it is further cooled. The combination of these three factors causes the icing.

To reduce the chance of regulator icing, use the following procedures.

- A. Make sure the breathing air source is dry. Scuba cylinders should be filled from a compressor with a good filtration system. The air source for the filling compressor should be from outdoors, and the filling of the tanks should be done on a cold dry day.
 - B. Place the AMCOMMAND I and the bottles in a warm location. This can be a temporary shelter with a portable heater.
8. Relief valve, factory set to 285 PSI. This valve is set to relieve the system pressure in the event the regulator should fail to control the pressure. The exhaust port for this valve is located between the diver output connections. If this valve should ever vent during a dive, the dive should be terminated immediately. Correct the cause of the problem before using the system again. You can control the outlet pressure by using the input valve (HP-1 or HP-2) as a throttle valve, closing the valve to reduce the pressure to the system. Open the valve slightly upon reaching the approximate pressure required; adjust the valve slightly to match the flow required by the diver. You can advise the diver to go to free flow, which will maintain a constant flow rate making it easier to control the pressure.
 9. LP input, the input is straight forward using a check valve to eliminate the need for another panel valve and facilitate switching from LP to HP air.
 10. Output gauge monitors the pressure to the diver. Gauge range is 0-400 PSI, 1-1/2% of full-scale accuracy.
 11. Diver output valves, 3/8 inch ball valves, 1/4 turn full open, unrestricted flow -- one valve for each diver.
 12. Pneumo Fathometer system, the depth measurement system consists of the one depth gauge, blow down valve, output connection, and gauge protector. The operation of the pneumo system is based upon the density of seawater that is 64.043 lb/ft³. The weight of a column of sea water one inch, by one inch, by one foot in height is .44473 (64.043 lbs. divided by 144 sq. inches). For underwater calculations this is rounded off to three places or .445 lbs. per square inch. Therefore by measuring the pressure, we can calculate the depth. To avoid doing the calculation we use a very accurate gauge that reads the pressure in pounds per square inch, but has the dial calibrated in feet of seawater.

Note: Fresh water has a density of 62.366 lbs/ft³, therefore the same calculations equals .433 lbs. per square inch. These differences must be taken into consideration when diving in fresh water, particularly decompression stops. See Section 10 for fresh water vs. sea water tables, "Diver's Handbook of Underwater Calculations", or U.S. Navy Diving Manual for additional information regarding fresh water diving.

The pneumo system operates on the bases of a tube extending from the surface of the water to the depth at which the measurement is going to be taken. Air (pressurized) is forced into the tube, until all the water is forced out of the tube. In fact, bubbles of air will come out of the end hose. The air is then shut OFF, (this eliminates any additional pressure from flow) the pressure will then stabilize equal to the pressure at the end of the hose. The pressure in the hose will then equal the pressure at the end of the hose, and the depth.

The pressure is then read on a very accurate gauge. The dial of the gauge is calibrated in feet of seawater rather than pounds per square inch (PSI), eliminating the need to convert from PSI to FSW.

The pneumo gauges have a 6-inch dial, dual scale 0-250 FSW/0-76 MSW, with 1-foot calibration increments. The accuracy of the gauge is 0.25% of full scale. Gauges are supplied with calibration certificates traceable to the National Bureau of Standards. The gauges must be Calibrated every six months to guaranty their accuracy. Gauges should be cross checked before every dive, if there is a discrepancy of more than 2% between gauges, the gauges must be calibrated before being placed in service.

Pneumo valves, one for each diver, shut off type valve, KEL-F seat for positive shut-off.

Each pneumo gauge is protected by an automatic valve which is factory set to shut off all pressure to the gauge when the pressure reaches or exceed the set point. The set point for a slow rising pressure is approximately 10% above full scale, 122 PSI. Fast rising pressures will be shut off at a lower pressure. The gauge protector will automatically release when the pressure is reduced. The gauge protector also includes a gauge snubber to protect the gauge from pulsations (shocks) in the pressure applied to the gauge.

9.2 Flow Diagram, Model 8111 Air Control

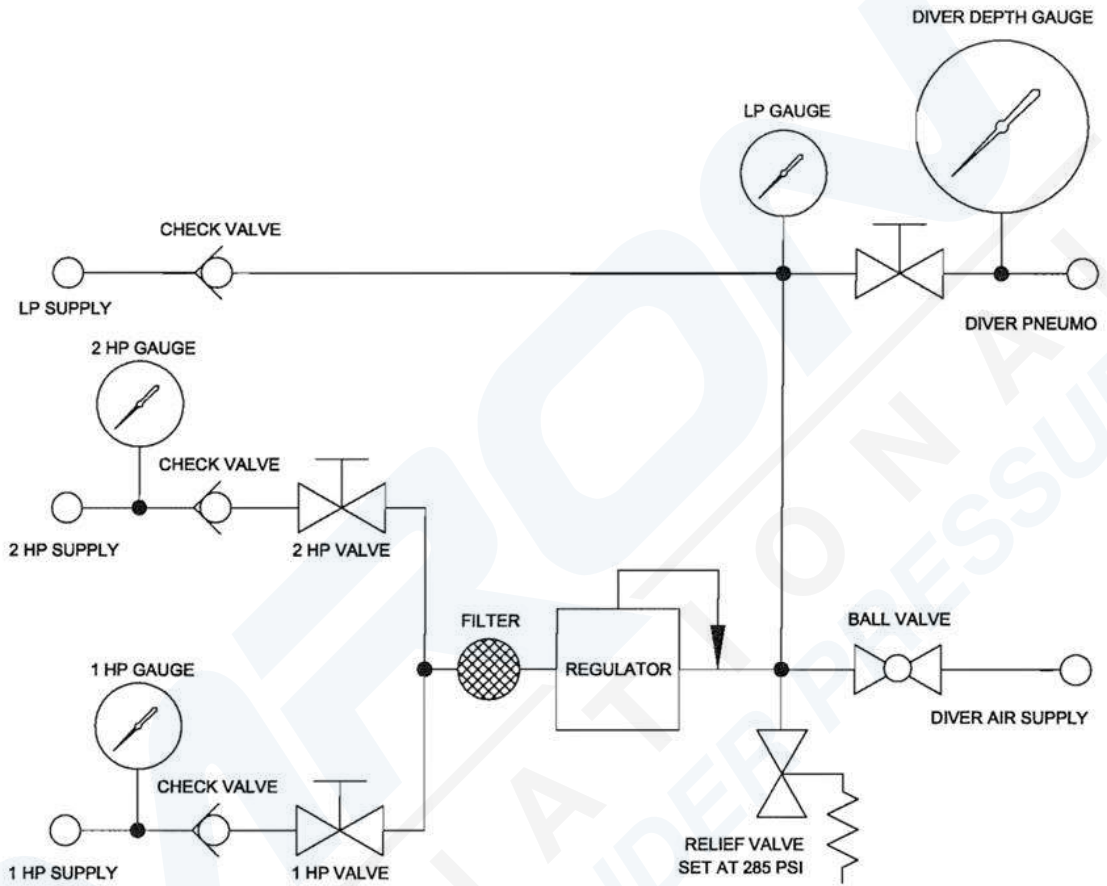

9.3 Electrical

The diver communicator is fundamentally an intercom, providing two way communication between the diver and the tender or operator. The Model 2810E 8111 can be operated in two different modes; 2-wire which requires the use of the push-to-talk switch or Full Duplex (4-wire) where voice conversations are the same as a telephone. In the Full Duplex method of operation, all persons on the system will be able to talk to each other, just as a party line phone system.

Although Full Duplex requires the use of four wires, it does not require a special grade or type of cable. Standard diver umbilical wire (Army surplus cable) will work very effectively. Once implemented, the system is very easily maintained and simple to use.

The 2810E 8111 incorporates another unique feature, the push -to -talk, hand-held microphone with automatic speaker cutout. This feature cuts out the talk back speaker when the tender is using the hand-held microphone. This eliminates the background noise found around most diving operations. Compressors, cranes and other construction equipment noise is effectively blocked out of conversation to the diver, reducing or eliminating "come back" or "say again".

Another innovation of the AMCOM series of diver communication systems is the design of the diver-input connections. The 5-way binding posts are spaced to except dual banana plugs. We strongly recommend the use of dual banana plugs as a measure to improve reliability of the communication system. Also all connections should be soldered. Bare copper wire corrodes very quickly, however wire which has been tinned (soldered) is almost impervious to corrosion. A system properly designed and implemented will provide years of satisfactory service. The Talkback speaker has been located in the pneumo panel for two reasons. The first is space; the second is to place the speaker in an optimum position in relation to the tender.

FULL DUPLEX (4-wire) - Tender and diver microphone are connected to amplifier inputs at all times. Tender headset and diver earphone are connected to audio output at all times.

BATTERY CHARGER - Maintains batteries at full float charge of 13.8 To 14.4 Volts. Front panel AC power "LED", indicates when AC power is applied to unit. Charger protects batteries from overcharge by automatically switching to float charge when batteries are fully charged.

BATTERY SENSE CIRCUIT - Electronically senses voltage from battery. Controls panel "LED" (battery condition indicator) which indicates: steady light - battery is Good, blinking light - low battery, no light - below reliable operational range or no voltage. Sense points, above 11 volts +/- .25 volts = Good (steady light). 11.0 to 10.0 volts +/- .25 volts = Low (blinking light). Below 10.0 +/- .25 volts = Bad, battery is below reliable operating range. Rechargeable batteries should not be operated below their normal operating voltage, permanent damage can occur. They should not be left in a non-charged state.

We strongly recommend the batteries be put on charge and left on charge when not in use. This will solve two problems, 1) the unit will always be ready to be put in service, and 2) it ensures the batteries will be charged as soon as the unit is returned from the field. In cold weather operation, expect reduced battery performance under cold conditions; also discharged batteries are subject to freezing and damage. The capacity of the battery will be reduced by approximately 40% at temperatures of 0°F. Charging of the batteries should be done within the temperature range of 32°F to 104°F. The ideal temperature for recharging is between 50°F to 86°F.

Battery Life - Several factors affect the life of the battery. These factors are discharge rate, depth of discharge, charge rate, operating temperature, and storage temperatures. The general rule of thumb is 300 charge cycles, or 3 years. The failure of the battery is not a complete catastrophic failure at the end of its life but a general deterioration in performance over the life of the battery.

10. MAINTENANCE

10.1 Review of Scheduled Maintenance

The inherent quality of your AMCOMMAND I will provide years of continuous failure-free service if properly used and maintained.

1. Before and after each dive: do Functional test, clean and inspect for damage.
2. Every 6 months: calibrate, functional test, clean and inspect for damage.
3. Every 12 months: in addition to the normal 6-month maintenance, service filter, leak test and check adjustments.
4. Every 36 months: in addition to the normal annual service replace all seals, gaskets, soft goods, and batteries.

In addition to the above scheduled maintenance, there are three important areas of user care that will determine the length of service you can expect from your equipment.

1. Take care of your equipment, protect it, and handle it with care during transportation to the job site. Ensure the equipment is protected. Select a work area where the equipment will be out of everyone's way, so that it doesn't get knocked over.
2. Clean your equipment. After the work is done at the job site, clean up the equipment. If you are on an extended work program, have the equipment operators clean the equipment during slow work periods. Cleaning involves wiping off the dirt with hot soapy water and a soft cloth. Soft Scrub, paint thinner, mineral spirits & turpentine can be used, if necessary, to clean only the case. Clean the terminals (diver communicator connections), using a solution of mild vinegar and a small brush.
3. Charge the batteries after each use; preferably leave the unit on charge when the equipment is not in use.

10.2 Scheduled Maintenance

- 10.2.1. **Before and after each dive:** inspect for any damaged parts, broken gauges, condition of high-pressure hose whip (inspect for cuts, abrasion, or general deterioration). Functional test of unit prior to dive, after dive record operator comments regarding maintenance required.
- 10.2.2. Every 6 Months: complete the before and after each dive inspection. Each diver pneumo gauge must be calibrated. Calibrate against dead weight tester or reference gauge. Pressure test PNEUMO section and repair any and all leaks. Record the results of inspection and gauge calibration.
- 10.2.3. **Every 12 months:** complete the above tests plus the following:

1. Remove high-pressure valve stems, inspect, clean, lubricate (use Christolube grease, Amron part No. MCG-111-20Z) and install. Check valve seat, threads, packing material for signs of wear or deterioration, replace if necessary.
2. Remove filter element and inspect. If filter element is dirty, make a determination as to where the contamination is coming from. Check the air source being used to determine where the contamination is coming from and correct. If filter is contaminated, remove high pressure section and clean all valves, inspect for signs of wear and deterioration, replace those parts which show signs of deterioration, clean and reassemble.
3. Check regulator action, check regulator maximum pressure which should be greater than 265 PSI.
4. Check relief valve actuation and shut off. Should vent at 285 PSI, close at 280 PSI sealing bubble tight.
5. Check action of pneumo gauge protectors, should shut off at 122 PSI +/- 5 lbs., on slow rising pressure.
7. Check all valves for bubble tight shut off. Replace seats as needed.
8. Leak test all fittings, Pressure test PNEUMO section.
9. Check accuracy of all gauges.
10. Record the results of the above tests.

10.2.4 **Every three years**, in addition to the above test:

1. Replace all soft goods, seals, gaskets and batteries.
2. Record the results of the above tests.

11. TROUBLESHOOTING AND REPAIR

11.1 General Information

Normal shop tools and procedures apply for all repairs.

During this section when you are instructed to remove a part or make an adjustment, you are first to remove all pressure from the system, or as a minimum from the section you are working on

11.1.1 Tubing and Tube Fittings

Repair, assembly, and inspection procedures. The common cause of leaks on tube fittings are debris, cracks, and deformed tube flares. Tube fittings, on initial make up tighten 1-1/4 turns from finger tight. To remake tube fittings, tighten finger tight plus 1/8 turn. Care must be used when disassembling tube fittings to ensure the fitting is held while the tube nut is turned.

11.1.2 Pipe Fittings

An over tightened pipe fitting is the most common cause of leaks. Before installing pipe fittings, remove all old Teflon tape, use stiff bristle brush. Replace Teflon tape by wrapping 1-1/2 turns of 1/2 inch tape, counter-clockwise on the threaded portion of the fitting. Use care when installing Teflon tape, leave one full turn of thread exposed and uncovered. This insures that a piece of tape does not get cut off and enter the system during the installation of the fitting.

11.1.3 To Remove the Diver Communicator

Loosen and remove the four screws on the front panel of the communicator. Lift communicator out of the air control panel.

11.1.4 Remove the Air Control Panel

Before attempting to remove the air control panel, loosen and remove the four screws on the front panel of the communicator. Lift communicator out of panel and set aside. Remove the lower panel by removing the screws from around the perimeter of the case. The air control panel can now be removed from the case.

11.2 Air Control

11.2.1 HP Gauges

Inspect for leaks. Any leak other than the input fitting is cause to replace the gauge. Internal leaks may cause the gauge face to bulge, if this occurs replace gauge. Inspect gauge blow-out plug for damage. Check accuracy of gauge against reference gauge. Gauges are not repairable, nor can they be adjusted. Discard and replace if problems are encountered.

11.2.2 HP Valve

A replacement valve is available from Amron. Check for leaks using a soap and water solution. Be sure to check valve body, valve stem packing area, and all end connections.

11.2.3 HP Check Valves

These are repairable. The Maintenance Kit is available from Amron and contains Viton seat and spring. Check for leaks using a soap and water solution. Be sure to check valve body and all end connections.

11.2.4 HP Filter

This is a replaceable element. The Maintenance Kit is available from Amron and contains the element, body gasket, and retainer spring. Check for leaks using a soap and water solution. Be sure to check valve body and all end connections.

11.2.5 HP-Regulator

Refer to section 13.5 Parts Locator for Model 44-2214-244-1068 on page 70 while reading this section. If the regulated pressure continues to rise at lock-up with no change in the control knob setting, suspect damaged or dirty main valve seat (item 058) or damaged valve stem (item 052). Bleed inlet pressure and inspect seat and valve stem by removing bonnet assembly (item 002) from regulator body (item 001). Inspect diaphragm (item 003) for cracks, damage or excessive wear.

11.2.6 Tescom Regulator 44-2214-244-1068 Repair & Soft Goods Kits

Regulator Kits are available in two configurations:

Soft Goods Kit P/N 389-6341 includes item 058 (valve seat) and item 051 (friction sleeve inner).

Repair Kit P/N 389-6346 includes all the items in the soft goods kit and the following items: 003 (diaphragm), 012 (filter), 052 (stem, valve), 053 (retainer seat), 059 (spring), and 061 (friction sleeve, outer).

11.2.7 Disassembly and Re-Assembly of the Regulator

1. Remove regulator from system.
2. Clamp the regulator in vise by the flats on the bottom of the body (item 001).
3. Turn CONTROL KNOB (item 008) counter-clockwise to insure removal of all spring force on the DIAPHRAGM (item 003).
4. Secure the lower section of the regulator body.
5. Using a 1-7/8 inch wrench, loosen the bonnet (item 002).

6. Remove bonnet assembly spring button, load spring (item 005), back-up plate (item 006), and diaphragm (item 003).
7. The main valve assembly can be disassembled by using a screwdriver to turn set retainer (item 053) counterclockwise until it is free of the regulator body (item 001). Valve stem (item 052 and seat spring (item 059) can now be lifted from body. The friction sleeves (items 051 and 061) can be removed from the body by either just inverting the body (if they are loose), or by carefully easing them out with a long, thin instrument inserted in the center holes.
8. Valve seat (item 058) may be removed from the seat retainer (item 053) using a sharp instrument.

The above steps provide the disassembly procedures. To reassemble, simply reverse these procedures.

Please observe the following torque values:

| | | |
|----------|-----------------|-----------------------|
| Item 053 | Retainer Seat | 70-80 in.-lbs. |
| Item 002 | Bonnet Assembly | 75 ft.-lbs. (3 times) |
| Item 055 | Nut, Hand Knob | 40-50 in.-lbs. |

Important: To achieve a proper metal to metal seal between the bonnet and the body, the bonnet must be torqued to the 75 ft.-lbs. value a minimum of 3 times.

11.2.8 Relief Valve

Check the operation of the vent valve by pressurizing the system until the vent begins to relieve the pressure. Decrease the pressure to stop the venting action, valve should stop bubble tight. If the relief valve does not operate correctly remove and disassemble, inspect. Replace any defective parts or clean, lubricate and reassemble.

To disassemble the relief valve, remove valve from system. In the output side of the valve there is a set screw, remove it. There is a second set screw under the first screw. The second set screw is the actual adjustment for the set point. The first screw is a locking screw that locks the adjusting screw at the set point.

There is another set screw at the other end of the valve, removing this allows the valve to be completely disassembled. When taking the valve apart be sure to lay the parts out in the order in which they were removed to facilitate assembly. Reverse the order to assemble. Pressurize the valve to check the setting of the valve. Remove the pressure and adjust as necessary to set the pressure. Turning the screw clockwise increases the pressure at which the valve will relieve.

11.2.9 LP Input check Valve

Same as the HP check valves except for size. During test, insure that the valve is not leaking by pressurizing the HP section and check the LP input for air leaking out of the input.

11.2.10 Diver's Pressure Gauge

Same as HP pressure gauges.

11.2.11 Diver's Output Valves

¼ turn ball-valves, to test, pressurize the input and turn the valves off, check that no air is leaking past the valve. The valves are repairable. They use Teflon seats which can be replaced. A maintenance kit is available from Amron. To replace, remove valve from system. Remove end pieces from valve, remove valve stem packing nut and remove stem. Teflon ball seal and stem packing can now be removed and replaced. To assemble, reverse the process.

11.3 Depth Monitoring

11.3.1 Pneumo Valves

Pneumo Valves are repairable. Remove stem by removing handle and step packing nut. Unscrew stem. Inspect stem, stem screw threads, valve body screw threads, brass and Teflon packing washer, and stem seat (KEL-F). Repair kits are available and include a complete stem assembly. Lubricate stem screw threads with Christolube grease, install stem assembly and permanently tighten packing nut.

11.3.2 Pneumo Gauges

Pneumo gauges are not field repairable nor are there any adjustments which can be made in the field. Check to make sure the blow-out plugs are in place. Calibrate every 6 months. Check the zero position of the gauge, a displaced zero is evidence of a gauge that has been subjected to over-pressurization.

Note: Check the gauge before using. If there is any question about the gauges integrity, have the gauge calibrated. Normal variations in zero are caused by variations in barometric pressure or changes in altitude. These variations normally will not exceed 10 feet.

11.4 Diver Communications

11.4.1 Diver Radio Field check Procedures

The following are procedures to allow a functional check in the field of your radio, using only a headset. These steps check all communication functions of the radio in both 2-wire and Full Duplex modes. This means that if your radio checks with these steps, any communication problems should be somewhere else in the system, such as the umbilical, connections, speakers and/or microphone.

11.4.2 Quick Full Duplex Check

1. Identify headset microphone lead and headset earphone lead. Plug into dual banana jack adapters (usually the microphone plug is red).
2. Plug in headset microphone to "Tender" "Microphone" (input) and headset earphone to "Tender" "Headset" (input/output). You should be able to hear yourself talk. This verifies Tender circuit.
3. Move headset microphone to "Diver 1" "Microphone" (input) and headset earphones to "Diver 1" "Earphone" (output). You should be able to hear yourself talk. This verifies Diver 1 circuit.

11.4.3 Comprehensive 2-Wire and Full Duplex Check

Set all volume controls at mid-scale, turn power on.

1. Identify headset microphone lead and headset earphone lead. Plug into dual banana jack adapters (usually the microphone plug is red.)
2. Plug headset earphone into "Tender" "Headset" (output) and the headset microphone into "Tender" "Microphone" (input). Turn power on, speaker off. Put on headset and speak into microphone, listening for your own voice. Adjust Diver-to-Tender volume; check that controls respond and that there is adequate volume. If you can talk to yourself, then Tender circuit is operating properly.

11.4.4 "Diver 1" Down-link Check

1. Move headset earphone plug from "Headset" (output) to "Microphone" "Diver 1". Talk into headset while pressing the Push-to-Talk switch. You should be able to talk to yourself with plenty of volume as long as the Push-to-Talk switch is depressed. This verifies 2-wire communication from tender to "Diver 1" and the function of relay K1.
2. Move headset earphone plug from "Microphone" (input) "Diver 1" to "Earphone" (output) "Diver 1". Talk into headset. There should be plenty of volume. This checks earphone output for Diver 1, Full Duplex.

11.4.5 Tender's Speaker Down-link Check

1. Unplug headset from "Microphone" (input) and turn "Speaker" on. Press Push-to-Talk and talk into speaker. You should hear yourself in the headset earphones. This verifies speaker section of relay K1. Turn speaker off.

11.4.6 "Diver 1" Up-link Check

1. Place headset microphone into "Microphone" (input) "Diver 1" and headset earphone plug in "Tender" "Headset" (output). Talk into headset. You should hear yourself in the headphones with plenty of volume. Press "Diver 1" On/Off while talking. When switch is depressed, your voice should cut out. This verifies "Diver 1" "Microphone" (input), relay K1 and "Diver 1 On/Off switch.

11.5 Troubleshooting

11.5.1 Unit Does Not Operate

Check to see that unit is turned on (speaker and headset switch). Check that battery condition is okay, (battery condition indicator). Check to see that connections are proper; correct if necessary. Use diver radio field check procedure to determine if problem is within the unit or elsewhere within the communication system. Check to see that internal P.C card connectors are properly seated. There should be no gap between the bottom of the connector housing and the circuit card. Push connector down and recheck.

11.5.2 Low Volume

Check volume control settings, adjust if desired. Check diver connections, correct if bad. Use diver radio field check procedure. Check for low batteries.

11.5.3 Garbled Voice to Diver

The Diver volume to Tender is set too high; reduce volume. Tender's headset is marginal, speaker has water in it and Diver's microphone is marginal, damaged comm cable or connections; substitute with known good units to determine exact problem and correct.

11.5.4 Garbled Voice to Tender

The Diver volume to Tender is set too high; reduce volume. Tender's headset is marginal, speaker has water in it, and Diver's microphone is marginal, damaged comm cable or connections; substitute with known good units to determine exact problem and correct.

11.5.5 Diver Cuts Out

Check for intermittent connection; substitute system components with known good units to determine exact problem and correct fault.

11.5.6 Connections

Most diver communications problems are caused by bad connections. The time spent in making good connections will result in years of good communications. All connections must be soldered to last for any period of time. Copper wire must be tinned as a minimum. It is strongly suggested that dual banana plugs be used for

topside connections. This provides a convenient and secure connection which will last for several years if treated with a reasonable amount of care.

All cable splices must be soldered. Splices should be staggered, covered with shrink tubing, preferably shrink tubing with an adhesive sealant, and a general splice cover to protect the connections. Potting of splices is a very good and professional approach, however not necessary to create a reliable splice.

11.5.7 Push-to-Talk Does Not Function but Tender Hears Diver (2-Wire)

Check connection to tender headset microphone if used. Check battery condition indicator to be steady green. The first function to fail because of low batteries is the actuation of the push-to-talk function. Find which push-to-talk switch is not working (, PTT Diver 1). It could be a broken wire on the switch terminals or a bad connection with PC card.

11.5.8 Diver Hears Tender but Tender Cannot Hear Diver (or volume is very low)

Check to see if Diver is connected to microphone and not earphone. Check to see that volume levels are not turned down. Inspect Diver connections and hat components.

11.5.9 Feedback

These situations may cause feedback: Tender's speaker on while headset is connected; unused Diver communications connected to system; damaged comm cable or connections (open or shorted wires or connections). Feedback can be caused by leakage between microphone wires and earphone wires in the umbilical. Leakage can be determined by a continuity test between the wires. Resistance for a new cable should be in excess of 10Meg ohms. In a situation where the comm cable is damaged, reduce the volume to diver as low as possible (reduce side tone), or go to 2-wire operation until cable can be repaired.

11.5.10 Distortion

Distortion may be caused by several conditions: Volume is adjusted too high; system is on the verge of feedback; marginal components (earphone or microphone). Check by substitution, replace defective components. Note: when operating with standby Diver who does not have his helmet / hat on, acoustic feedback or distortion may occur. Correct by disconnecting his comm cable (at least his microphone, which will reduce overall system noise).

12. REFERENCE MATERIAL

12.1 Diving Log, U.S Navy (Chart)

| DIVING CHART - AIR | | | | | | Date | |
|----------------------|--------|--------------------------------|--------------------|--------------------------|-------|---------------------|--|
| NAME OF DIVER 1 | | DIVING APPARATUS | | TYPE DRESS | | EGS (PSIG) | |
| NAME OF DIVER 2 | | DIVING APPARATUS | | TYPE DRESS | | EGS (PSIG) | |
| TENDERS (DIVER 1) | | | TENDERS (DIVER 2) | | | | |
| LEFT SURFACE (LS) | | AND DEPTH (fsw) | | REACHED BOTTOM (RB) | | AND DESCENT TIME | |
| LEFT BOTTOM (LB) | | TOTAL BOTTOM TIME (TBT) | | TABLE & SCHEDULE USED | | TIME TO FIRST STOP | |
| REACHED SURFACE (RS) | | TOTAL DECOMPRESSION TIME (TDT) | | TOTAL TIME OF DIVE (TTD) | | REPETITIVE GROUP | |
| DESCENT | ASCENT | DEPTH OF STOPS | DECOMPRESSION TIME | | TIME | | |
| | | | WATER | CHAMBER | WATER | CHAMBER | |
| | ↑ | 10 | | | L | | |
| | ↑ | 20 | | | R | | |
| | ↑ | 30 | | | L | | |
| | | 40 | | | R | | |
| | | 50 | | | L | | |
| | | 60 | | | R | | |
| | | 70 | | | L | | |
| | | 80 | | | R | | |
| | | 90 | | | L | | |
| | | 100 | | | R | | |
| | | 110 | | | L | | |
| | | 120 | | | R | | |
| | | 130 | | | L | | |
| PURPOSE OF DIVE | | | | REMARKS | | | |
| DIVER'S CONDITION | | | | DIVING SUPERVISOR | | | |

12.2 Repetitive Dive Worksheet

REPETITIVE DIVE WORKSHEET

I. PREVIOUS DIVE:

_____ minutes Standard Air Table
 _____ feet No-Decompression Table
 _____ repetitive group designation

II. SURFACE INTERVAL:

_____ hours _____ minutes on surface.
 Repetitive group from I _____
 New repetitive group from surface _____
 Residual Nitrogen Timetable _____

III. RESIDUAL NITROGEN TIME:

_____ feet (depth of repetitive dive)
 New repetitive group from II. _____
 Residual nitrogen time from _____
 Residual Nitrogen Timetable _____

IV. EQUIVALENT SINGLE DIVE TIME:

_____ minutes, residual nitrogen time from III.
 + _____ minutes, actual bottom time of repetitive dive.
 = _____ minutes, equivalent single dive time.

V. DECOMPRESSION FOR REPETITIVE DIVE:

_____ minutes, equivalent single dive time from IV.
 _____ feet, depth of repetitive dive

Decompression from (check one):

- Standard Air Table No-Decompression Table
- Surface Table Using Oxygen Surface Table Using Air
- No decompression required

Decompression Stops: _____ feet _____ minutes
 _____ feet _____ minutes
 _____ feet _____ minutes
 _____ feet _____ minutes
 _____ feet _____ minutes

Scheduled used _____
 Repetitive group _____

12.3 No Decompression Limits

(Non-repetitive Dives Only) U.S. Navy Diving Manual (Air Decompression)

| Depth FSW | Bottom Time |
|-----------|-------------|
| 40 | 200 |
| 50 | 100 |
| 60 | 60 |
| 70 | 50 |
| 80 | 40 |
| 90 | 30 |
| 100 | 25 |
| 110 | 20 |
| 120 | 15 |
| 130 | 10 |
| 140 | 10 |
| 150 | 5 |
| 160 | 5 |
| 170 | 5 |
| 180 | 5 |
| 190 | 5 |

NOTE: OSHA Regulations Require: A decompression chamber capable of recompressing the Diver at the surface to a minimum of 165 FSW (6ATA) and shall be available at the dive location for: A) surface supplied air-diving to depths deeper than 100 FSW.

12.4 Gauge Pressure For
Gauge Pressure in PSI

| Depth In | Feet of Fresh Water | Seawater |
|----------|---------------------|----------|
| 10 | 4.33 | 4.45 |
| 20 | 8.66 | 8.90 |
| 30 | 12.99 | 13.35 |
| 40 | 17.32 | 17.80 |
| 50 | 21.65 | 22.25 |
| 60 | 25.98 | 26.70 |
| 70 | 30.31 | 31.10 |
| 80 | 34.64 | 35.60 |
| 90 | 38.97 | 40.05 |
| 100 | 43.30 | 44.50 |
| 110 | 47.63 | 48.95 |
| 120 | 51.96 | 53.40 |
| 130 | 56.29 | 57.85 |
| 140 | 60.62 | 62.30 |
| 150 | 64.95 | 66.75 |
| 160 | 69.28 | 71.20 |
| 170 | 73.61 | 75.65 |
| 180 | 77.94 | 80.10 |
| 190 | 82.27 | 84.55 |
| 200 | 86.60 | 89.00 |

12.5 Equivalent Depths of Seawater & Fresh Water

| Depth | Equivalent Depth |
|------------------|---------------------|
| Feet of Seawater | Feet of Fresh Water |
| 10 | 10.30 |
| 20 | 20.30 |
| 30 | 30.90 |
| 40 | 41.20 |
| 50 | 51.50 |
| 60 | 61.80 |
| 70 | 72.10 |
| 80 | 82.40 |
| 90 | 92.70 |
| 100 | 103.00 |
| 110 | 113.30 |
| 120 | 123.60 |
| 130 | 133.90 |
| 140 | 144.20 |
| 150 | 154.50 |
| 160 | 164.80 |
| 170 | 175.10 |
| 180 | 185.40 |
| 190 | 195.70 |
| 200 | 206.00 |

13. DRAWINGS

General

The following drawings illustrate the electrical and mechanical details of the diver communication unit. The corresponding parts lists for each drawing are detailed in the parts lists section.

Revisions

As drawings are updated, information about changes is incorporated into a revision sheet. This revision sheet appears in the manual immediately after the drawings. It lists the drawing number, the reference designator of the part or parts involved, a description of the revision, and the effective serial number of the change. With this information, the technician can determine the correct drawing for the current version and any previous version(s) of the unit covered by this manual. If the revision is applicable for all versions of the unit, it is not included in the revision notice, as the change applies to all units.

13.1 Parts Locator, Air Control Panel (Front)

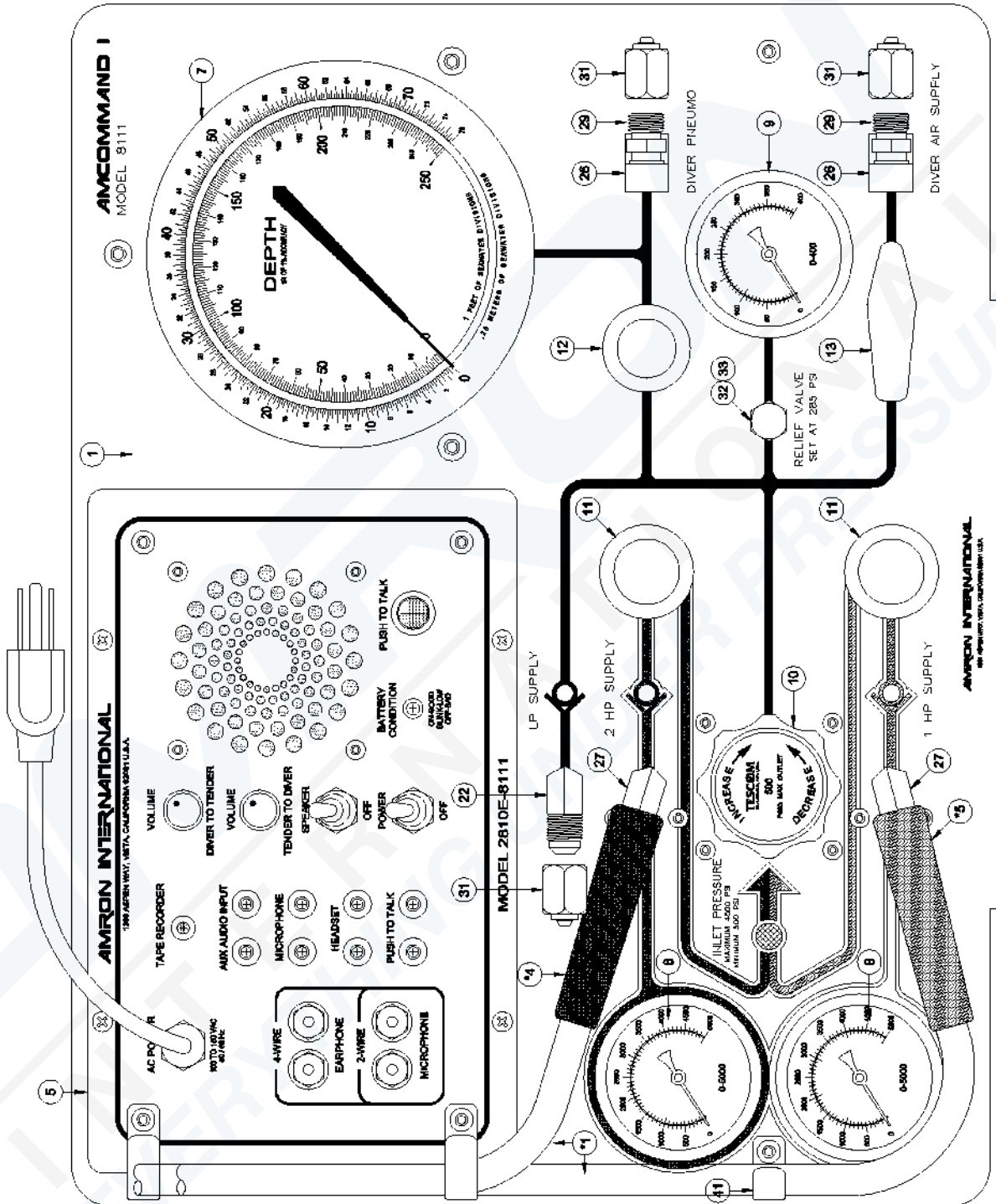

* USED ON 8111-900 ASSEMBLY

13.2 Parts Locator, Air Control Panel 8111 (Back)

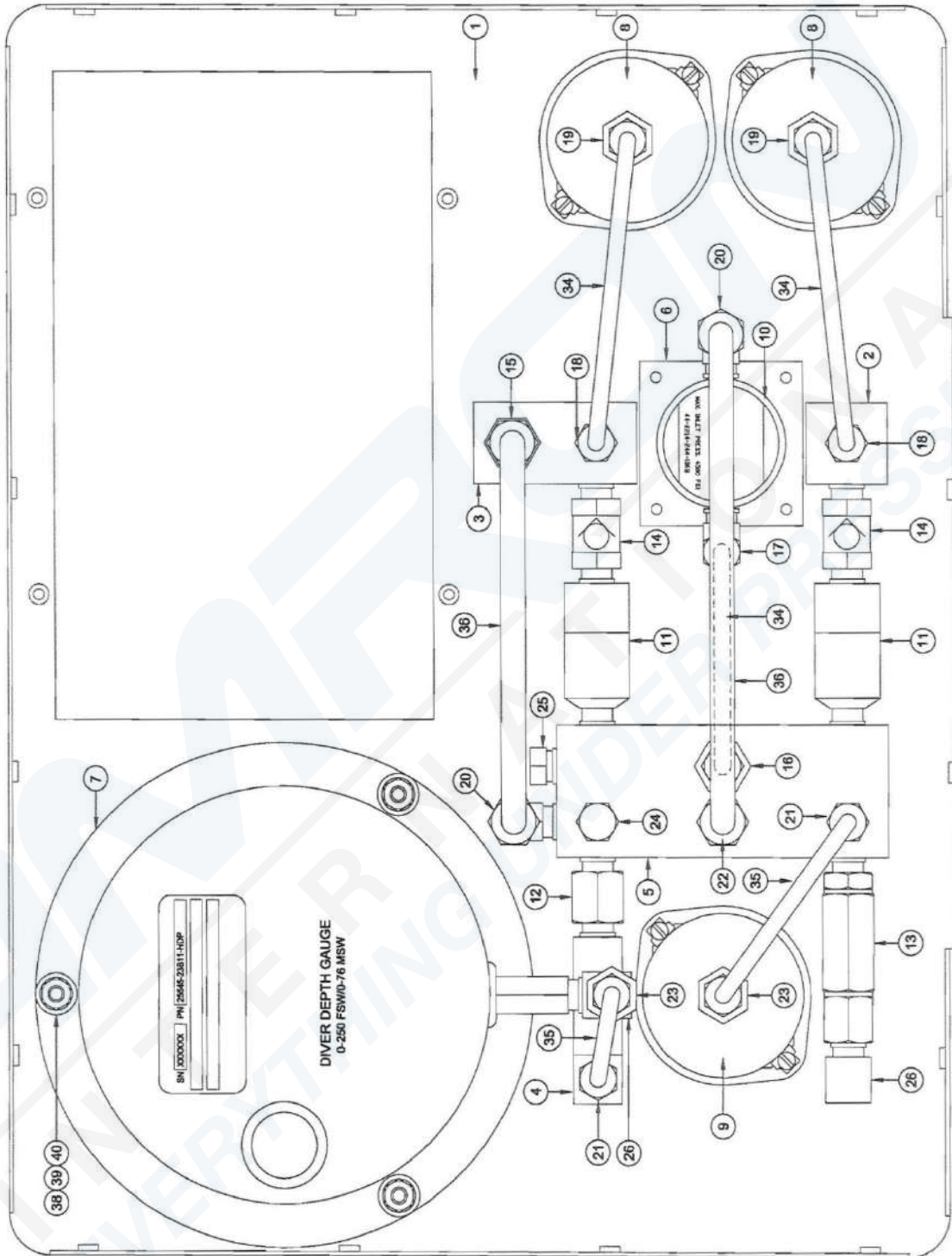

13.3 Parts Locator, Communicator

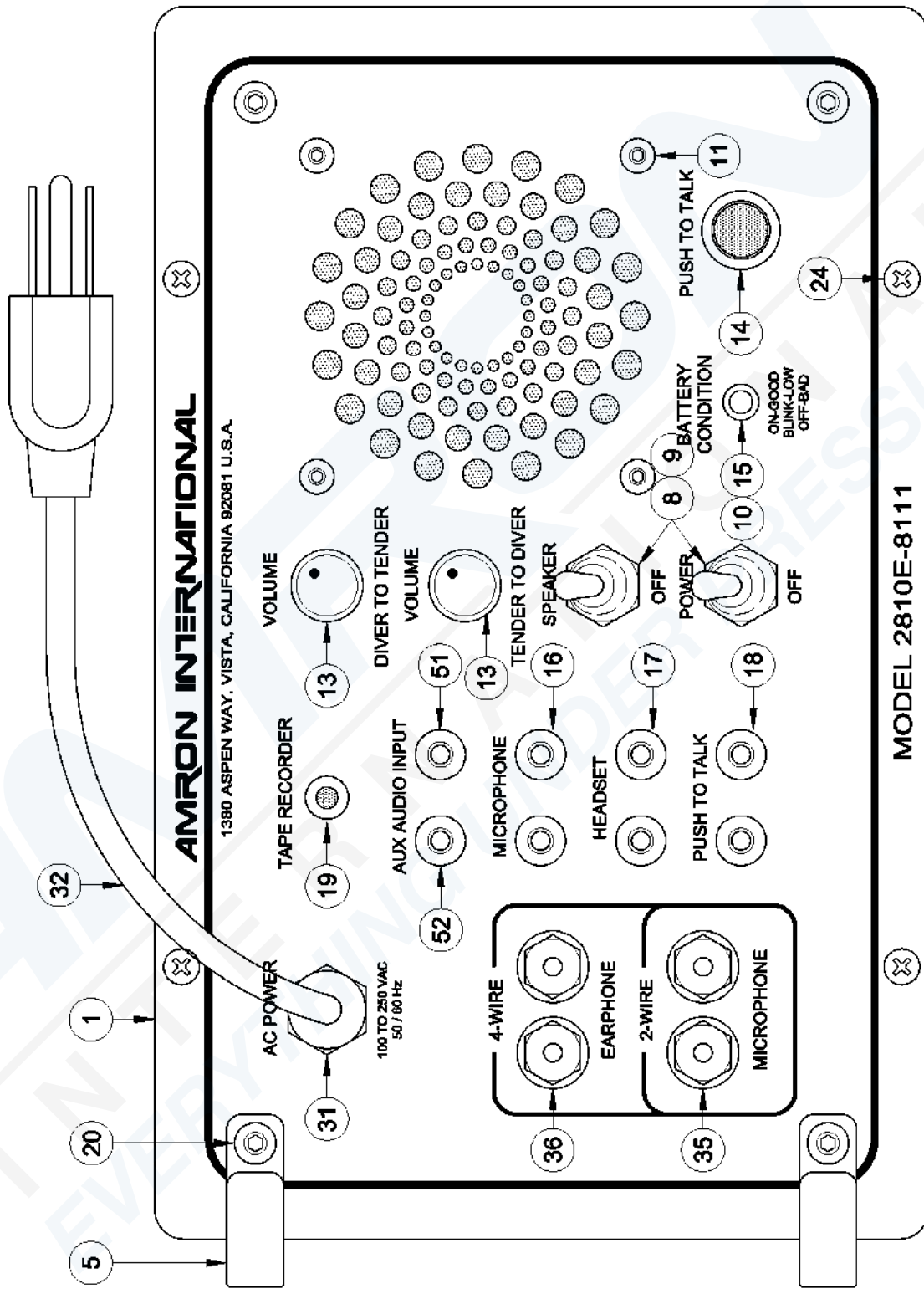

13.4 Parts Locator, Regulator Model 44-2214-244-1068

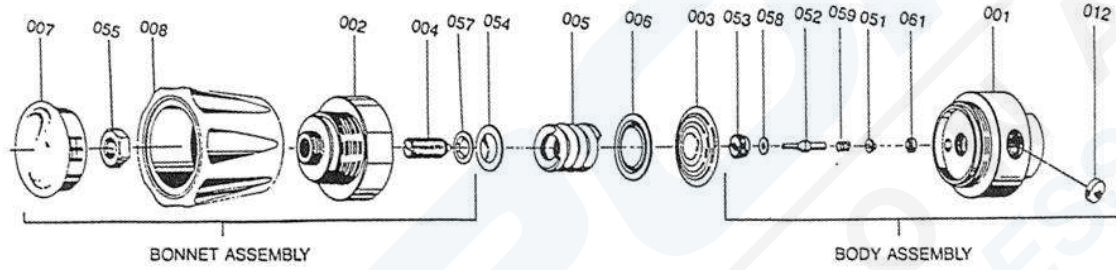

14. PARTS LIST

General

The following parts lists include all mechanical and electrical parts. The following information will be useful in interpreting data which is not self-explanatory.

Revisions

The parts lists in this manual are for the current model of Diver Communicator as of the printing date.

To Order Replacement Parts:

Amron international, Inc.
1380 Aspen Way, Vista, California, 92081 U.S.A.
Telephone: (760) 208-6500 Fax: (760) 599-3857
Email: sales@amronintl.com
Web: www.amronintl.com

When ordering replacement parts, you should give as much information as possible to enable us to supply the correct part. This information should include the part number, description, reference designator, value, radio model number, and serial number. Failure to provide sufficient information may hinder our ability to fill your parts orders promptly and correctly.

14.1 AMCOMMAND I Air Control Delivery System

| Part No. | Description |
|------------|--------------------------|
| 8111-300 | Case Assembly |
| 8111-400 | A/C Panel Assembly |
| 8111-500 | Hose & Yoke Assembly |
| 2810E-8111 | Radio Assembly |
| 2405-28 | Hand Held Microphone PTT |
| 8111-UM | Manual for Amcommand I |

14.2 8111-300 Case Assembly

| Part No. | Description |
|----------|------------------------------|
| 8225-004 | Bracket, Yoke |
| 8111-006 | Bracket, Hose Routing (twin) |

14.3 8111-400 Air Control Panel Assembly

| Reference | Part No. | Description |
|-----------|------------------|--------------------------------------|
| 1 | 8111-001 | Front Panel *** Not For Sale *** |
| 2 | 8111-002 | Manifold, HP Inlet, Brass |
| 3 | 8111-003 | Manifold, HP Inlet/LP Outlet, Brass |
| 4 | 8111-004 | Manifold, LP Pneumo Outlet, Brass |
| 5 | 8111-005 | Manifold, HP Inlet/LP Outlet, Brass |
| 6 | 8110-002 | Bracket, Regulator |
| 7 | 25545-23B11-HDP | Pneumo Gauge, 6" 250 FSW- 76 MSW |
| 8 | 711725206000 | Gauge, 2.5" 0-6000 PSIG, |
| 9 | 71172520600 | Gauge, 2.5" 0-600 PSIG, 1% Accuracy |
| 10 | 44-2214-244-1068 | Regulator, 4500 Psi Inlet |
| 11 | HLV-2 | Valve, HP Select |
| 12 | 4M-V4LK-B-YEL | Valve, Needle, Brass, Yellow Handle |
| 13 | 4M4F-B6LJ-BP | Valve, Ball, Panel Mount, Brass |
| 14 | 4M-C4L-1/3-SS | Check Valve, 1/3 Psi Cracking, 316SS |
| 15 | 4M6Z-C4L-1/3-B | Check Valve, 1/3 Psi Cracking, Brass |

| | | |
|----|-----------------|---------------------------------------|
| 16 | 4M4Z-F4L-50-SS | Filter, Inline, 50 Micron, 316 SS |
| 17 | CBZ-SS-4-4 | Male Elbow, #4x 1/4" NPT, 316 S/S |
| 18 | FBZ-SS-4-4 | Male Connector, #4 X 1/4" NPT, S/S |
| 19 | GBZ-SS-4-4 | Female Connector, #4 X 1/4" NPT S/S |
| 20 | CBZ-B-6-4 | Male Elbow, #6 X 1/4" NPT, Brass |
| 21 | FBZ-B-4-4 | Male Connector, #4 X 1/4" NPT, Brass |
| 22 | FBZ-B-6-4 | Male Connector, #6 X 1/4" NPT, Brass |
| 23 | GBZ-B-4-4 | Female Connector, #4 X 1/4" NPT |
| 24 | HP-B-1/4 | Hex Plug, Brass, 1/4" MNPT |
| 25 | HP-SS-1/4 | Hex Plug, 1/4" MNPT, 316SS |
| 26 | 2202P-4-4 | Street Elbow, 1/4" MNPT, Brass |
| 27 | CTX-SS-4-4 | Male Elbow, 1/4" JIC X 1/4" NPT, S/S |
| 28 | VTX-B-6 | Male Elbow, 45°, 3/8" JIC X 1/4" MNPT |
| 29 | MA-742 | Adapter, O2 X 1/4" MNPT, Brass |
| 30 | MPF-222 | Street Elbow, 45°, 1/4" MNPT, Brass |
| 31 | 8200-016 | Dust Cap With Retainer, Brass |
| 32 | 8600-014 | Vent Cap, Brass, Nickel Plated |
| 33 | 4CPA2-150-B | Relief Valve, Set at 285 PSIG |
| 34 | SSTUS1/4X035316 | Tubing, 1/4" O.D. X .035, 316L SS |
| 35 | CUTUS1/4 | Tubing, 1/4" O.D. X .028, Soft Copper |
| 36 | CUTUS3/8 | Tubing, 3/8" O.D. X .049, Soft Copper |
| 41 | 8111-007 | Bracket, Hose Routing, SS |

14.4 8111-500 HP Yoke & Hose Assembly

| Part No. | Description |
|-----------|--------------------------------------|
| 72HP | Hose Whip, 72", HP 5000 PSI |
| FTX-B-4-4 | Male Connector, 1/4" JIC X 1/4" MNPT |
| 9913-02 | Yoke & Bleeder, (Cga850) Scuba Yoke |
| RP75-BLUE | Hose Protector, Vinyl, Blue |
| RP75-RED | Hose Protector, Vinyl, Red |

14.5 Recommended Spare Parts for Air control

| Part No. | Description |
|-------------|---|
| 822091-B | Repair Kit, for P/N 4M-V4LK-BP-YEL |
| 802065-4 | Repair Kit, for P/N 4M4F-B6LJ-BP |
| 802045 | Repair Kit, for P/N 4M-C4L-1/3-SS, 4M6Z-C4L-1/3-B |
| KIT-F4-50-V | Repair Kit, for P/N 4M4Z-F4L-50-SS |
| 389-6346 | Repair Kit, for P/N 44-2214-244-1068 |
| 389-6341 | Soft Goods Kit, for 44-2214-244-1068 |
| 4CPA2-150-B | Relief Valve, 150 PSI |
| 72HP | Hose Assy, 72" HP 5000 PSI |

14.6 44-2214-244-1068 Regulator Assembly

| Reference | Part No. | Description |
|-----------|------------------|-------------------------|
| 001 | *consult factory | Body, Regulator |
| 002 | 9212-1 | Bonnet Assembly |
| 003 | 9384 | Diaphragm |
| 004 | 8266-2 | Screw, Adjust |
| 005 | TES-1196 | Spring, Load |
| 006 | 8596 | Plate, Back-up |
| 007 | 4659-0500 | Hole Plug |
| 008 | TES-4540-1 | Hand knob |
| 012 | 8203 | Filter |
| 051 | 8263 | Friction Sleeve (Inner) |
| 052 | 6489-6 | Stem, Valve |
| 053 | 6491-1 | Retainer Seat |
| 058 | 6490 | Seat, Valve (Kel-F) |
| 055 | 1149-1 | Nut, Hand Knob |
| 059 | TES-6495 | Spring |
| 061 | 8265-6 | Friction Sleeve (outer) |

*** Regulator Repair Kit: Part No. 389-6346

*** Regulator Soft Goods Kit: Part No. 389-6346

14.7 2810E-8111 Communicator Assembly

| Reference | Part No. | Description |
|-----------|------------------|-----------------------------------|
| 1 | 2810E-8111-001 | Panel, Front *** Not For Sale *** |
| 5 | 8111-006 | Bracket, Hose Routing (Twin) |
| 6 | 570-1000-02 | PC Card Assembly |
| 7 | 100-0000-00 | Speaker; 3.5in 8ohms16w. |
| 8 | 7580K6 | Switch, Toggle SPST |
| 9 | 5168 | Seal, Half Boot Toggle |
| 10 | LEDGREEN | Led, Green Bright |
| 13 | P16NP-10K | Potentiometer, 10k Ohm W/Knob |
| 14 | PBSWITCH | Switch, Push Button, No, Sealed |
| 15 | LEDHOLDER-BLK.25 | Clip, Panel Mount Led |
| 16 | 1498-102 | Jack, Banana Red |
| 17 | 1498-103 | Jack, Banana Black |
| 18 | 1498-107 | Jack, Banana Yellow |
| 19 | ME161-2003 | Jack, Phono |
| 32 | P-2392 | Cord, Ac Euro 3 Cond. |
| 33 | 2823-6003 | Charger Chassis Assembly |
| 34 | 2890-05 | Battery, Recharge, 12v Gel 7amp |
| 35 | 14002R | 5-Way Binding Post (Red) |
| 36 | 14002B | 5-Way Binding Post (Black) |
| 51 | 160-1001-01 | Jack, RCA Red Panel Mount |
| 52 | 160-1001-02 | Jack, RCA White Panel Mount |

14.8 2405-28 Hand Held Microphone – Push-to-Talk

| Part No. | Description |
|----------|---------------------------|
| 2405-28 | Microphone, Hand Held PTT |
| 14001B | Jack, Banana Dual Black |
| 14001Y | Jack, Banana Dual Yellow |

14.9 2810A-FS-01 Field Spares Kit for Model 2810E-8111

| Part No. | Description |
|--|-----------------------------|
| *NOTE: Specify Unit Serial Number | |
| 105-0602-001 | Jack, Tip Red |
| 105-0603-001 | Jack, Tip Black |
| 1498-103 | Jack, Banana Black |
| 1498-107 | Jack, Banana Yellow |
| 1498-102 | Jack, Banana Red |
| 14002B | Binding Post, Black |
| 14002R | Binding Post, Red |
| 7580K6 | Switch, Toggle SPST |
| 5168 | Seal, Switch Toggle Shaft |
| PBSWITCH | Switch, Push Button |
| P16NP-10K | Potentiometer, 10k Ohm |
| LEDGREEN | LED Green Bright |
| LEDHOLDER-BLK.25 | Clip, Panel Mount Led |
| 0034.6019 | Fuse 3.15A/250v Micro quick |
| 0034.6617 | Fuse 1.6A/250v slow |

