

User Manual
For
Amron International, Inc.

**Model 2810-01 Portable
One Diver Communicator**

S/N _____



1380 Aspen Way, Vista California 92081-8349

United States of America

Phone: (760) 208-6500

Fax (760) 599-3857

Email: sales@amronintl.com

Web: www.amronintl.com

This manual and the information contained herein are provided for use as an operation and maintenance guide. No license or rights to manufacture, reproduce, or sell either the manual or articles described herein are given. Amron International, Inc. reserves the right to change specifications without notice.

Copyright© 2018 Amron International, Inc.

TABLE OF CONTENTS

1	INTRODUCTION AND SPECIFICATIONS	1
1.1	INTRODUCTION.....	1
2	ACCESSORIES.....	3
2.1	ACCESSORIES	3
3	CONTROLS AND CONNECTIONS.....	4
3.1	TENDER AND DIVER CONTROLS.....	4
3.2	DRAWING, 2-WIRE CONNECTIONS.....	8
3.3	DRAWING, 4-WIRE (FULL DUPLEX) CONNECTIONS.....	9
3.4	DRAWING, PUSH-TO-TALK MICROPHONE CONNECTIONS.....	10
3.5	DRAWING, HEADSET CONNECTIONS	11
4	OPERATION.....	12
4.1	OPERATION	12
4.2	MODES OF OPERATION.....	14
5	MAINTENANCE AND TROUBLESHOOTING.....	16
5.1	DIVER COMMUNICATOR CHECK PROCEDURES.....	16
5.2	GENERAL MAINTENANCE.....	18
5.3	RECOMMENDED MAINTENANCE SCHEDULE	18
5.4	TROUBLESHOOTING	19
6	DRAWINGS	22
6.1	2810-01 CHASSIS PARTS LOCATOR.....	23
6.2	2810-01-400 FRONT PANEL PARTS LOCATOR.....	24
7	PARTS LISTS.....	25
7.1	MODEL 2810-01 CHASSIS COMPONENTS	25
7.2	2810-01-400 FRONT PANEL COMPONENTS.....	25
7.3	2810A-FS-02 FIELD SPARES KIT	26
8	LIMITED WARRANTY AND SERVICE POLICY.....	27

1 INTRODUCTION AND SPECIFICATIONS

1.1 INTRODUCTION

Congratulations on purchasing the most advanced and powerful portable One Diver Communicator in the diving industry! Our engineering team has integrated the latest advancements to produce the industry's most intelligible and reliable One Diver Communicator.

The 2810-01 is a full featured, one-diver, hardwire communicator that uses state-of-the-art electronics and introduces even more features to the diving community. The first is a digital audio power amplifier which significantly reduces the current draw resulting in almost twice the battery life. The 2810-01 uses a new audio filtering network for improved sound clarity and communications. An auxiliary audio input allows the diver to listen to audio from an MP3 player while remaining in constant communication with the tender. Please note that this feature is only available when diving in 4-Wire mode. These new features allow the AMCOM I 2810-01 to remain the most advanced one-diver communicator on the market. To enjoy all the features, it is important that the tender read and understand the entire manual including all warnings.

The 2810-01 comes standard with rechargeable 12V sealed lead-acid battery, built-in internal battery Power Supply, and can be operated from either a 90-264 VAC, internal 12 VDC battery, or an external 12 VDC power source. The power supply is a medical grade device with electrical isolation for maximum safety to the diver.

Like previous members of the AMCOM I family, the 2810-01 can operate in 2-Wire or 4-Wire (Full Duplex) communication modes. There is a single volume control for the up-link (Diver-to-Tender) and another volume control for the down-link (Tender-to-Diver). Designed for a long and dependable service life, the 2810-01 has a powder coated, stainless steel front panel with a waterproof speaker and heavy-duty switches with waterproof seals. The 2810-01 is enclosed in a rugged yellow plastic case with all the user controls and connections located on the front panel for ease of use.

ELECTRICAL SPECIFICATIONS

Frequency Response	300 - 4000 Hz
DC Power Supply Voltage	12 VDC Nominal, (9 Volts Minimum - 16 Volts Maximum)
AC Power Supply Range	90-264 VAC, 50-60 Hz
Entertainment Input Impedance	>47 kOhms
Nominal Power Supply Voltage	12 VDC
Operational Supply Voltage	9 - 18 VDC
Sensitivity (Input)	1.8 mVRMS
Maximum Output Power (4 Ohm Load, 14 VDC)	20 Watts
Battery Life.....	85 Hours

MECHANICAL SPECIFICATIONS

Panel	Powder Coated Stainless Steel
Enclosure	High Impact Resistant Plastic
Size Length.....	10.62 in. (26.98 cm)
Width	9.68 in. (24.59 cm)
Height	6.87 in. (17.45 cm)
Weight	11.45 Lbs. (5.20 kg)



2 ACCESSORIES

Amron produces a series of accessories designed to operate with the entire line of AMCOM diving communicators.

2.1 ACCESSORIES

The following accessories are available for the AMCOM I communicator. Accessories can be ordered at any time.

2.1.1 AMRON HEAVY-DUTY HEADSET - MODEL 2401-28

The Model 2401-28 is a heavy-duty headset with boom microphone. It comes equipped with color-coded, dual banana plugs that mate directly to AMCOM diver communicators. It includes a six foot (1.8 meter) cord.

2.1.2 AMRON STANDARD HEADSET - MODEL 2460-28

The Model 2460-28 is a light and comfortable headset designed for extended wear at an economical price. It comes equipped with color-coded, dual banana plugs that mate directly to AMCOM diver communicators as well as a spiral cord that can be extended up to 8 feet (2.4 meters).

2.1.3 AMRON PUSH-TO-TALK MICROPHONE - MODEL 2405-28

The Model 2405-28 is a hand-held, noise canceling, push-to-talk microphone that provides excellent sound quality to the diver. It comes equipped with a spiral cord that can be extended up to 6 feet (1.8 meters).

2.1.4 AMRON REMOTE WALK-AND-TALK MODULE - MODEL 2822-28

Designed for 4-Wire (Full Duplex) applications, the Model 2822-28 provides the tender with mobility around the dive site while maintaining communications with the diver. It comes equipped with a small clip-on belt module that contains the connectors for the headset, and 25 feet (7.6 meters) of lightweight flexible cable. Custom cable lengths are available.

2.1.5 AMRON REMOTE PUSH-TO-TALK MODULE - MODEL 2821-28

Designed for 2-Wire applications, the Model 2821-28 provides the tender with mobility around the dive site while maintaining communications with the diver. It comes equipped with a small clip-on belt module that contains a Push-to-Talk switch, connector for the headset, and 25 feet (7.6 meters) of lightweight flexible cable. Custom cable lengths are available.

2.1.6 AUDIO ADAPTOR CABLE - AMRON PART NUMBER 180-1000-00

Adapter cable is 6.5 feet (2 meter) long with two RCA Phono plugs that connect the auxiliary audio input to a standard 3.5 mm stereo phone plug which mates to the headphone jack of most common portable audio devices.

3 CONTROLS AND CONNECTIONS

Before using the 2810-01 diver communicator, the tender should be familiar with all the operating controls and connections. While reading this manual, you will find capitalized words such as PANEL SPEAKER. These words are to remind the reader that additional information can be found in this section of the manual.

3.1 TENDER AND DIVER CONTROLS

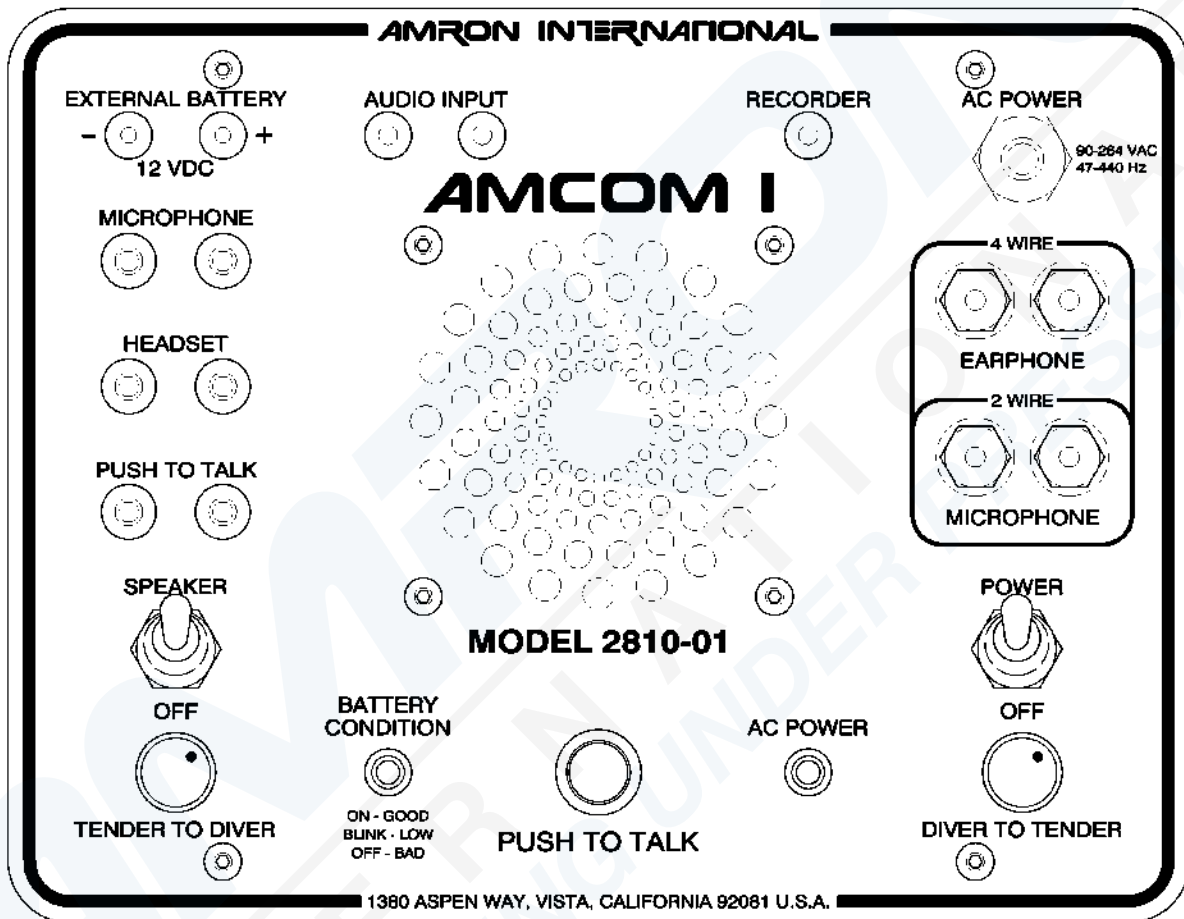

- 3.1.1 **POWER SWITCH** – This switch controls power to the unit.
- 3.1.2 **SPEAKER SWITCH** – This switch allows the tender to turn off the speaker. If the tender is using a headset, it may be necessary to turn off the speaker in order to prevent acoustic feedback.
- 3.1.3 **PUSH-TO-TALK BUTTON** – This button allows the tender to talk to the diver when operating in the 2-Wire mode. It is not necessary to use this control in the Full Duplex (4-Wire) mode. When using Full Duplex mode, this control allows the tender to interrupt the diver by forcing them into listen only mode.

- 3.1.4 **TENDER TO DIVER VOLUME** - This control sets the volume for the diver's earphone including any signal from the AUXILIARY AUDIO INPUT. Rotate this knob clockwise to increase the volume.
- 3.1.5 **DIVER TO TENDER VOLUME** - This control sets the volume for the tender's earphone and/or panel speaker. Rotate this knob clockwise to increase the volume.
- 3.1.6 **PANEL SPEAKER** - A waterproof, acoustic speaker that allows the tender to monitor communication to the diver and act as a microphone by using the PUSH-TO-TALK BUTTON. The volume level is controlled by the DIVER TO TENDER VOLUME control and it can be turned off using the SPEAKER SWITCH.
- 3.1.7 **BATTERY CONDITION INDICATOR** - This LED is used by the tender to determine the available battery level. A steady green light means that the battery charge level is greater than 30%. When the battery reaches approximately 30% remaining life, the LED will start blinking at a rate of about once per second. When the battery reaches its end-of-charge, the LED will turn off and the 2810-01 will go into shutdown mode to prevent damaging the communicator or rechargeable battery. It is advised that the rechargeable battery be connected to the Power Supply as soon as possible once the BATTERY CONDITION INDICATOR starts blinking. While there should be enough time to safely complete a normal diving operation, the exact amount of time is dependent on the age and condition of the sealed lead acid battery.
- 3.1.8 **TENDER HEADSET** - This is the dual banana jack (color-coded black) that functions as both an output (earphone) and input (microphone) for the tender as controlled by the PUSH-TO-TALK BUTTON and PUSH-TO-TALK JACK. Using this connection, the tender can be wired in either 2-Wire or 4-Wire (Full Duplex) mode regardless of the mode used for the diver.

To connect the tender in the 4-Wire (Full Duplex) mode, connect the earphone (black) banana plug of the headset to this jack and the microphone (red) to the TENDER MICROPHONE jack (red) as shown in the wiring diagram in section 3.6. In this mode, the tender does not have to use the PUSH-TO-TALK BUTTON to communicate with a diver who is also connected in the 4-Wire (Full Duplex) mode. This configuration can be used even if the diver is connected in 2-Wire mode. In that situation, the tender is required to use the PUSH-TO-TALK BUTTON or PUSH-TO-TALK JACK.

The headset microphone is always active which means that there can be acoustic feedback between the PANEL SPEAKER and the microphone if the tender is near the 2810-01. To prevent this, the PANEL SPEAKER can be turned off using the SPEAKER SWITCH. Another option is to move the tender away from the 2810-01 by using the Amron Model 2822-28 Walk-and-Talk Module accessory. This allows the tender to communicate while other members of the surface crew listen using the PANEL SPEAKER. This module comes with 25 feet (7.6 meters) of cable (custom cable lengths are available).

The tender can also be connected in 2-Wire mode by stacking both the earphone (black) and microphone (red) banana plugs into this jack as shown in the wiring

diagram in section 3.2. The diver does not have to be connected in 2-Wire mode if the tender is in 2-Wire mode. In order to talk to the diver, the tender must use either the PUSH-TO-TALK BUTTON or PUSH-TO-TALK JACK. Since the headset microphone is not active until one of the push-to-talk methods is used, there is no chance for acoustic feedback to occur and surface conversation or noise is not transmitted to diver and the PANEL SPEAKER can be left on. This may, for some situations, make for a better overall diving experience. If the tender requires more mobility at the dive site, the Amron Model 2821-28 Remote Push-to-Talk Module can be used to extend the headset cable. It includes a push-to-talk button on a clip-on belt module and comes standard with 25 feet (7.6 meters) of cable (custom cable lengths are available).

The tender may also use the optional Amron Model 2405-28 Push-to-Talk Microphone. This microphone comes with two color-coded banana plugs. The black plug goes into the TENDER HEADSET jack and the yellow plug goes in the PUSH-TO-TALK jack. To communicate with the diver, the tender presses the button on the side of the microphone. There is no chance of acoustic feedback since the PANEL SPEAKER is cut-off when the tender uses the microphone. When using the Push-to-Talk Microphone, the SPEAKER SWITCH must be turned on in order to hear the diver.

- 3.1.9 **TENDER MICROPHONE** - This is a dual banana jack (color-coded red) that functions as the microphone input from the tender's headset. It is only used if the tender is in 4-Wire (Full Duplex) mode.
- 3.1.10 **PUSH-TO-TALK JACK** - This is a dual banana jack (color-coded yellow) that allows for remote keying of the push-to-talk function of the 2810-01. The difference between using the PUSH-TO-TALK JACK and PUSH-TO-TALK BUTTON is that the button allows the tender to communicate using the PANEL SPEAKER as a microphone. If both are used at the same time, the PANEL SPEAKER is active as a microphone. This allows a crew member to talk to the diver using the PANEL SPEAKER even if the tender is away from the 2810-01 using the Remote Push-to-Talk Module in 2-Wire mode.
- 3.1.11 **DIVER MICROPHONE** - This is a dual 5-way binding post jack (color-coded red) that functions as both an output (earphone) and input (microphone) for the diver as controlled by the PUSH-TO-TALK BUTTON and PUSH-TO-TALK JACK. Using this connection, the diver can be wired in either 2-Wire or 4-Wire (Full Duplex) mode regardless of the mode used for the diver.

To connect the diver in 4-Wire (Full Duplex) mode, connect the diver microphone to this jack and the diver earphone the DIVER EARPHONE jack as shown in the wiring diagram in section 3.3. The diver can use this mode even if the tender is wired in 2-Wire mode.

To connect the diver in 2-Wire mode, connect both the diver microphone and earphone to this jack. If the diver umbilical uses banana plugs, simply stack both plugs into this jack as shown in the wiring diagram in section 3.2. In this mode, the diver microphone will be active and heard on tender headset and/or PANEL

SPEAKER unless the PUSH-TO-TALK BUTTON or PUSH-TO-TALK JACK is activated.

- 3.1.12 **DIVER EARPHONE** - This is a dual 5-way binding post jack (color-coded black) that functions as the output for the diver's earphone. It is only used when the diver is in 4-Wire (Full Duplex) mode.
- 3.1.13 **EXTERNAL BATTERY JACK** - The 2810-01 can be powered using an external battery or power supply via the two color coded TIP jacks. The red TIP jack is the positive power input and the black is the negative power input. The input voltage must be between 9 and 18 VDC and must be able to supply a peak current of 3 Amps for proper operation. The following warnings need to be heeded when using the EXTERNAL BATTERY JACK. A minimum wire size of 18 AWG and maximum wire run of 3 feet (1 meter) are recommended.

WARNING!

If you use an external power supply, the maximum voltage needs to be limited from 9-16 Volts.

- 3.1.14 **RECORDER OUTPUT** - This is a single RCA Phono jack (color-coded black) that provides a transformer isolated of both the diver and tender communications. It is designed to drive the standard line-level inputs of audio or video recorders with input impedances as low as 600 Ohms. The RECORDER OUTPUT will not record the signal from the AUXILIARY AUDIO INPUT.
- 3.1.15 **AUXILIARY AUDIO INPUT** - This is a set of two RCA Phone jacks (color-coded red and white) that provides a means to connect an external audio signal for diver entertainment. Although this input will accept a stereo audio source, it will be converted into a monaural signal before going to the diver. This signal is not heard in either the tender headset or via the PANEL SPEAKER. The earphone output of most MP3 players can be connected to this input using an adaptor cable like the Amron Audio Adaptor Cable (Amron Part Number 180-1000-00). This feature will only work if the diver is wired in 4-Wire (Full Duplex) mode.

There is no separate volume control provided for the diver entertainment signal. The audio device provides the volume control. It is advised at the start of diving operation, and before the external audio device is turned on, that the tender adjust and verify the TENDER TO DIVER VOLUME level is correct and comfortable for the diver. Then starting with the lowest volume, adjust the volume on external device until a comfortable level is achieved. If the tender is connected in the 4-Wire (Full Duplex) mode, the volume level should not be so loud as to prevent the diver from hearing the tender. If the tender is connected in the 2-Wire mode, then the entertainment will be cut off whenever the PUSH-TO-TALK BUTTON or PUSH-TO-TALK JACK is used. The PUSH-TO-TALK BUTTON can be used by the tender to cut off the entertainment even if the tender is connected in the 4-Wire (Full Duplex) mode.

3.2 DRAWING, 2-WIRE CONNECTIONS

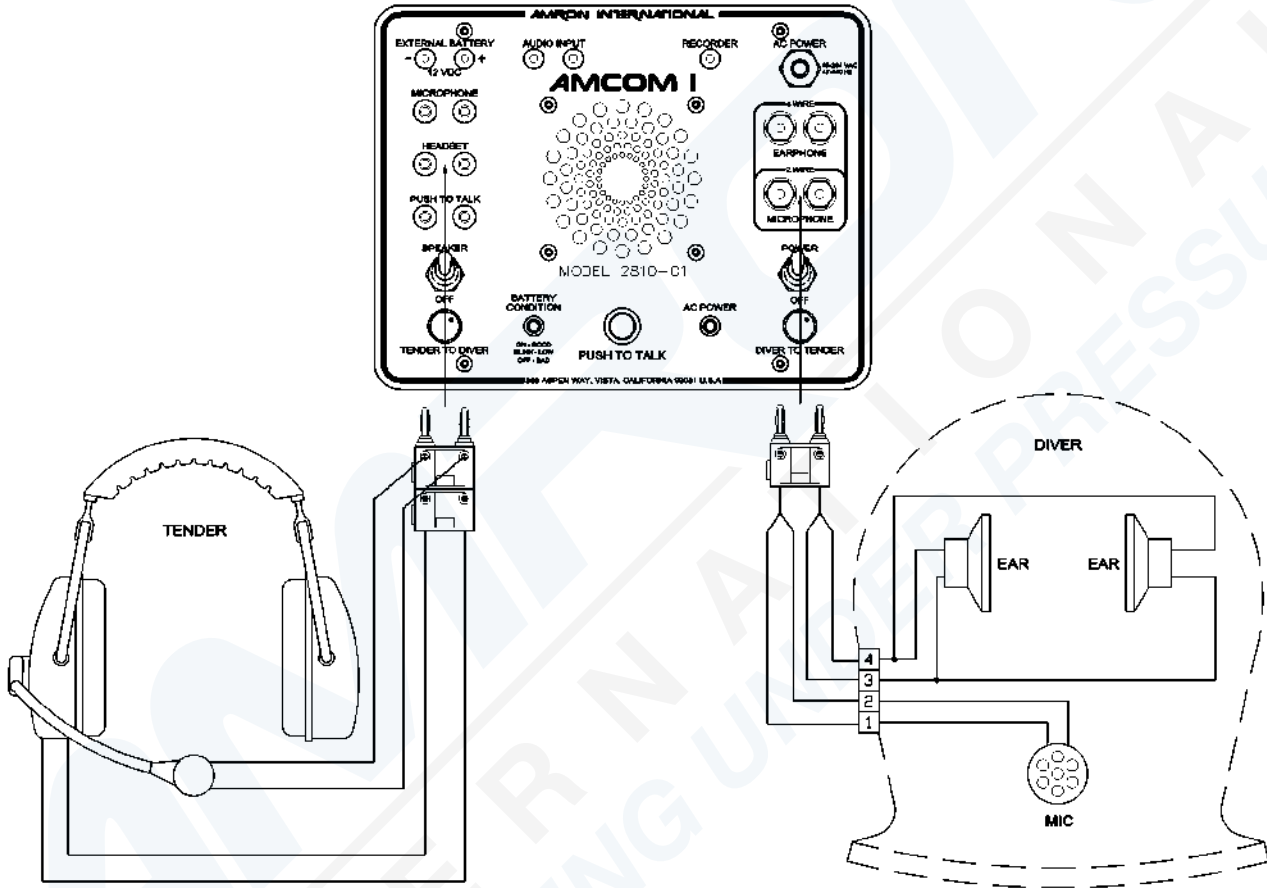

3.3 DRAWING, 4-WIRE (FULL DUPLEX) CONNECTIONS

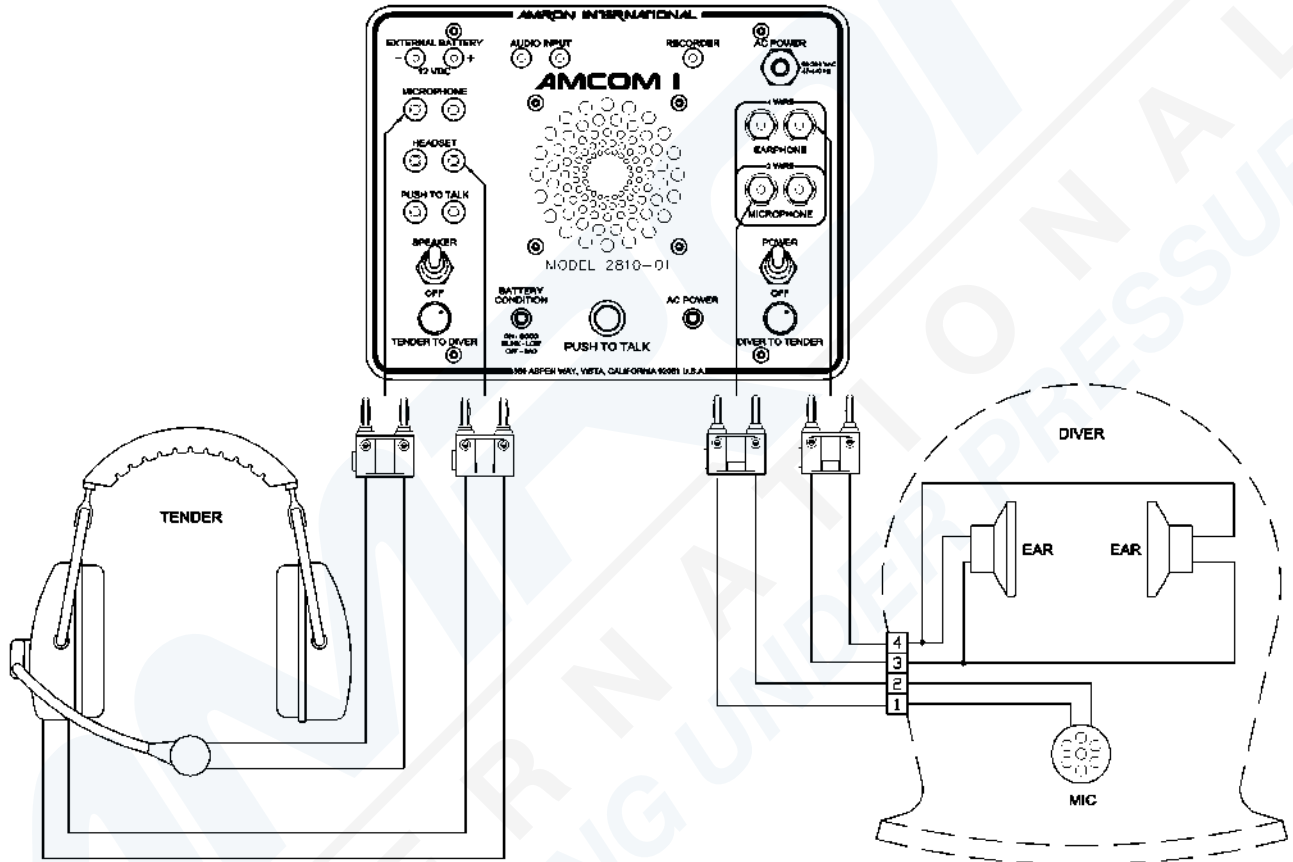

3.4 DRAWING, PUSH-TO-TALK MICROPHONE CONNECTIONS

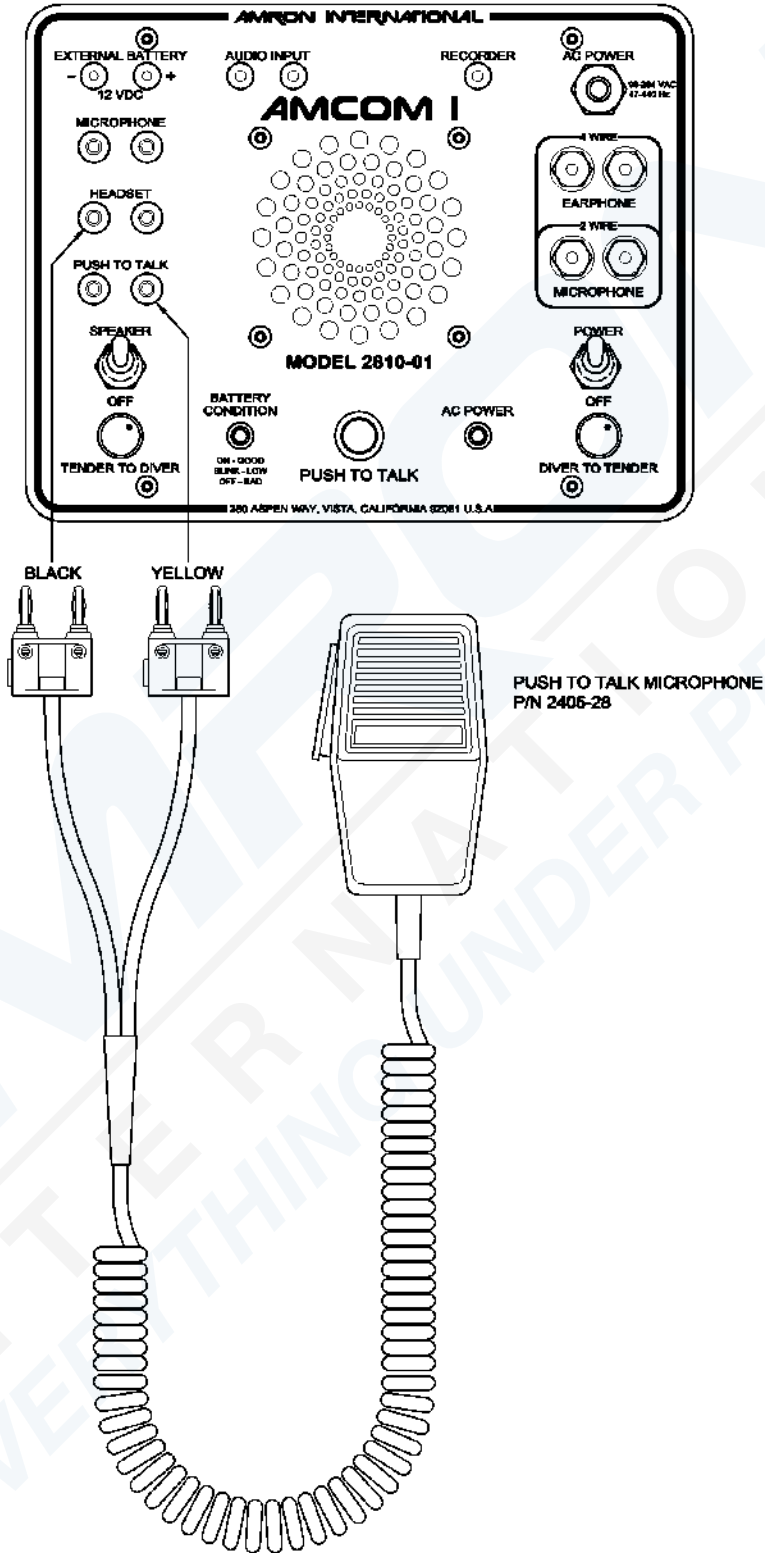

3.5 DRAWING, HEADSET CONNECTIONS

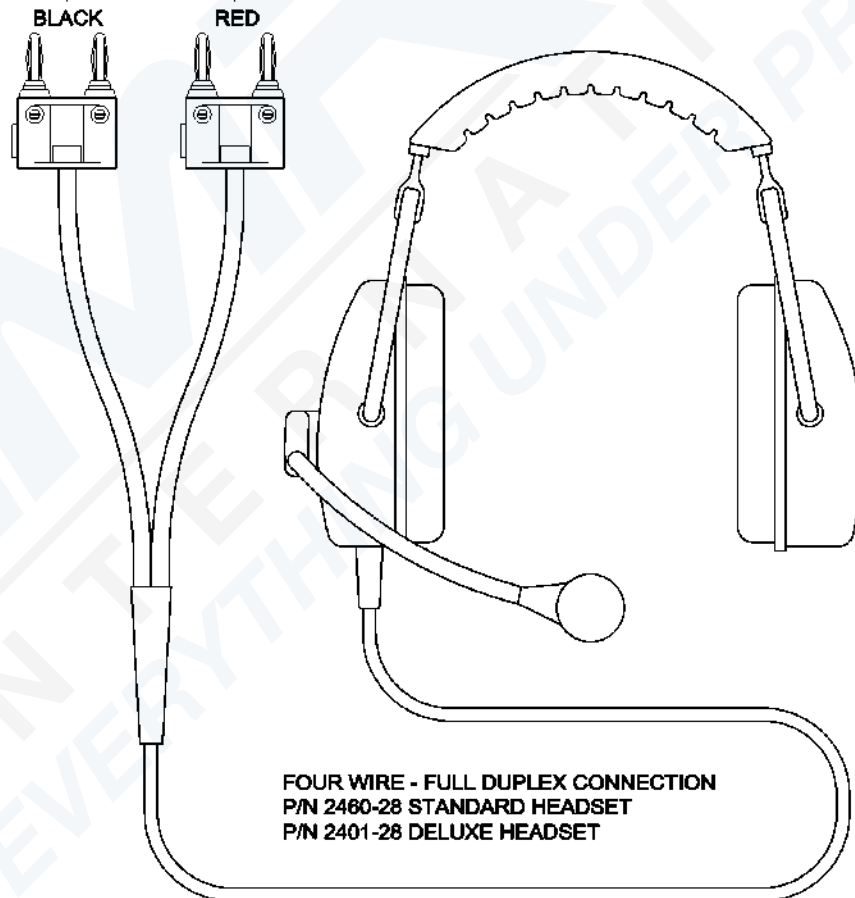
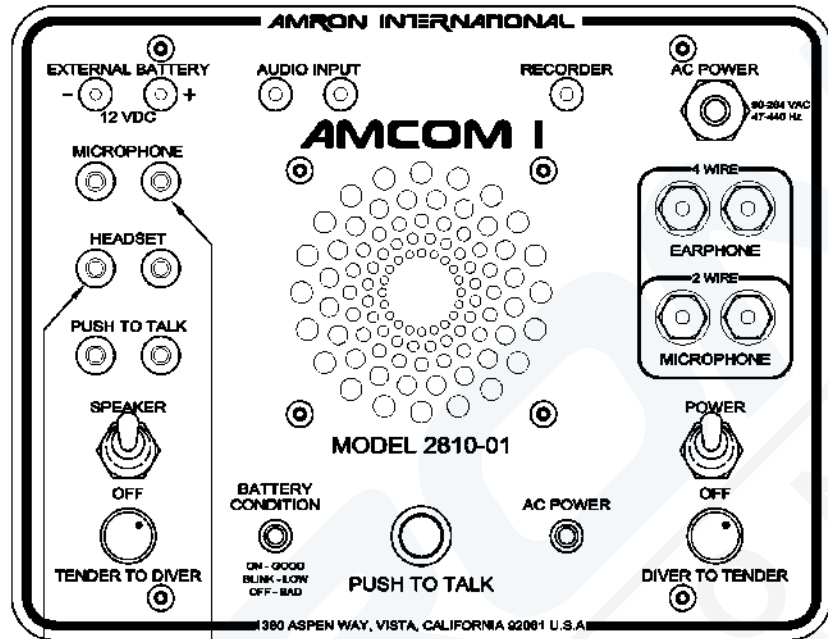

4 OPERATION

4.1 OPERATION

The 2810-01 comes standard with rechargeable 12V sealed lead-acid battery, built-in internal battery Power Supply, and can be operated from either a 90-264 VAC, internal 12 VDC battery, or an external 12 VDC power source. The power supply is a medical grade device with electrical isolation for maximum safety to the diver. The unit is housed in a durable yellow enclosure and can be accessed by simply releasing the two latches located on the front.

WARNING!

When operating your Amron Diver Communicator from AC mains, it is critical to use a Ground Fault Circuit Interrupter (GFCI) and/or isolation transformer for tender and diver safety. Surges and spikes are common on AC lines found onboard ships, from local generators, or at the end of a long extension lines. These spikes can exceed 1kV! Such spikes can be high enough to cause the input fuses on the power supply to blow and, in extreme cases, actually damage the charging circuitry. Amron uses a medical grade power supply to isolate such faults to ensure that they will not cause a safety issue for the diver or tender. Amron cannot guarantee that non-Amron power supplies meet the same high standards and strongly advises against using any such device to power your diver communicator.

4.1.1 CHARGING THE BATTERY

The Model 2810-01 has a built-in internal Power Supply with integrated intelligent battery charging circuitry and 12V rechargeable sealed lead acid battery. To charge the battery, simply plug in the AC power cord to an AC outlet ranging 90-264 VAC, 50-60 Hz.

The internal battery Power Supply is designed to charge the battery in float mode so the Power Supply can be left on indefinitely, without damage, to ensure the battery is fully charged and the unit is ready to use. A fully discharged battery will take approximately 10 hours to reach full charge (depending on the age of the battery and the surrounding temperature). To ensure maximum service life, the battery should be fully charged at least once every six months.

The operating time for a fully charged battery is approximately 85 hours. The exact operating time depends on the age of the battery and the ambient temperature. The sealed lead acid battery used in the 2810-01 has a service life of 300 full charge/discharge cycles or 3 years. The BATTERY CONDITION INDICATOR will start to blink when the battery has approximately 30% remaining charge. To maximize the service life, the battery should be recharged as soon as possible after the indicator starts to blink. When the battery reaches the full discharge state, the 2810-01 will shut down to prevent damage to both the battery and the electronics.

4.1.2 BATTERY CONDITION CHECK

Turn all the volume controls to minimum and turn on the POWER SWITCH. The state of the battery is shown on the BATTERY CONDITION INDICATOR as follows:

- STEADY GREEN - the battery is good and has more than 30% remaining life
- BLINKING GREEN - the battery is low and has less than 30% remaining life
- OFF or NO LIGHT - the battery is depleted and needs to be changed/recharged before use

The BLINKING GREEN light provides a warning that the battery is low and should be changed or recharged before starting the dive operation. When the indicator starts BLINKING GREEN during dive operations, there is, depending on age of the battery and the ambient temperature, approximately 24 hours of remaining battery life. This should be sufficient time to safely complete dive operations. A battery that has not been used for a long period of time will exhibit a higher voltage than the actual charge state. This is known as surface charge and will quickly dissipate once the unit is turned on. It is recommended that the unit be left on for 5 minutes before relying on the BATTERY CONDITION INDICATOR.

4.1.3 BATTERY INSTALLATION

The 2810-01 is supplied with a single 12V gel-cell sealed lead-acid battery. To remove and install the battery, remove the four (4) screws from the front panel and position panel assembly out of the way to access the battery. Set screws aside in a safe place where they won't be lost. Remove color-coded slide terminals and unsecure Velcro battery strap. Lift out old battery and install new battery, secure battery strap, connect color-coded slide terminals, and secure front panel assembly with four (4) screws.

4.1.4 OPERATING ON AC POWER

Amron has designed the 2810-01 to operate with a range of 90-264 VAC, 50-60 Hz. The medical grade power supply allows for proper isolation that prevents any possible leakage of AC current into the communicator. This protects the diver and tender from electrocution.

WARNING!

When operating your Amron Diver Communicator from AC mains, it is critical to use a Ground Fault Circuit Interrupter (GFCI) and/or isolation transformer for tender and diver safety. Surges and spikes are common on AC lines found onboard ships, from local generators, or at the end of a long extension lines. These spikes can exceed 1kV! Such spikes can be high enough to damage the charger circuitry. Amron cannot guarantee that non-Amron power supplies meet the same high standards and strongly advises against using any such device to power your diver communicator.

4.2 MODES OF OPERATION

The communicator has the ability to operate in either 2-Wire or 4-Wire (Full Duplex). Both the diver and tender can be connected in either mode and a combination of modes can be used. For example, the diver can be connected in 4-Wire (Full Duplex) mode to take advantage of the new entertainment feature while the tender is wired in 2-Wire mode. If either the diver or the tender is wired in 2-Wire mode, the tender must use a push-to-talk, either the PUSH-TO-TALK BUTTON or PUSH-TO-TALK JACK, when talking to the diver.

2-Wire communication is defined as a single communication path, normally the diver is the priority signal path – tender listens to diver. Signal reversing is accomplished by pushing the PUSH-TO-TALK BUTTON – diver hears tender. Often times a 4-conductor communication cable is used with 2 wires tied together as a pair for redundancy, this is still a 2-Wire system. Since only one person can talk at a time, there is a level of discipline that goes with using 2-Wire mode in order to obtain clear communication. One advantage of 2-Wire is that the tender's microphone is not active unless one of the two push-to-talk controls, PUSH-TO-TALK BUTTON or PUSH-TO-TALK JACK, are active. This eliminates any possible acoustic feedback between the tender's microphone and the PANEL SPEAKER. It also prevents noise from the surface reaching the diver and allows the tender to communicate with other members of the surface crew without involving the diver. If the diver is connected in 2-Wire mode, the AUDIO AUXILIARY INPUT cannot be used to deliver entertainment to the diver.

4-Wire (Full Duplex) communication is defined as a dual communication path, a signal path (a pair of wires) for up-link and a signal path (a pair of wires) for down link. A common example of Full Duplex communication is the telephone. 4-Wire (Full Duplex) has the advantage of natural communication without having to use the PUSH-TO-TALK BUTTON. This keeps the tender's hands free to perform other task. It does not require the same level of discipline to achieve clear communications that 2-Wire does. It has the advantage that neither the diver nor the tender are cut off when the other is talking. Because the diver's microphone is not connected in parallel with the earphone, the diver is louder and potentially clearer in 4-Wire (Full Duplex) mode.

4.2.1 2-WIRE

To connect the diver in 2-Wire mode, connect the communication umbilical wires to the DIVER MICROPHONE binding post jack on the 2810-01 as shown in the wiring drawing in section 3.2. If the umbilical uses a banana plug, simply insert the plug into the binding post jack. Verify that it is firmly and completely seated. This may require that the external plastic nut be tightened down. If the umbilical uses bare wires, loosen the external plastic nut of the binding post jack. Either insert the bare end of the wire into the hole in the metal shaft of the binding post or firmly wrap the wire around the shaft. Tighten the nut until the bare wire is firmly fastened by the nut. The nut should not be fastened on the insulation of the wire nor should any of the bare wires touch.

The tender can operate in 2-Wire without a headset or push-to-talk microphone by using the PANEL SPEAKER as both a speaker and microphone. When the tender wants to talk to the diver, he presses the PUSH-TO-TALK BUTTON on the front panel and speaks clearly into the PANEL SPEAKER at a distance of between 4 to 8 inches (10 to 20 cm). When done speaking, the tender releases the PUSH-TO-TALK BUTTON to allow the diver to communicate.

When the tender uses a headset or push-to-talk microphone, follow the corresponding wiring diagram in sections 3.4 and 3.5. When using the Amron Model 2405-28 Push-to-Talk Microphone, the tender presses the push-to-talk button on the side of the microphone and speaks clearly at a distance of between 1 and 2 inches (25 to 51 mm). When done speaking, the tender releases the push-to-talk button to allow the diver to communicate.

Whenever either the diver or the tender are connected in 2-Wire, the tender must use one of the push-to-talk methods when talking to the diver.

4.2.2 4-WIRE (FULL DUPLEX)

To connect the diver in 4-Wire (Full Duplex) mode, connect the communication umbilical wires to the DIVER MICROPHONE and DIVER EARPHONE jacks as shown in wiring diagram in section 3.3. If the umbilical uses a banana plug, simply insert the plug into the correct binding post jack. Verify that it is firmly and completely seated. This may require that the external plastic nut be tightened. If the umbilical uses bare wire ends, loosen the external plastic nut of the binding post jack. Either insert the bare end of the wire into the hole in the metal shaft of the binding post or firmly wrap the wire around the shaft. Tighten the nut until the bare wire is firmly fastened by the nut. The nut should not be fastened on the insulation of the wire nor should any of the bare wires touch. If the AUDIO AUXILIARY INPUT is to be used to deliver entertainment to the diver, then the diver must be wired in 4-Wire (Full Duplex) mode. The diver microphone will be louder in 4-Wire (Full Duplex) mode than in 2-Wire mode. This can be a significant advantage when using longer dive umbilical cables.

To use 4-Wire (Full Duplex) mode, the tender must use a headset and connect per the instructions in 3.1.8. The tender will have to use the PUSH-TO-TALK BUTTON to communicate if the diver is in 2-Wire mode. The tender can also use the PUSH-TO-TALK BUTTON to cut off the AUDIO AUXILIARY INPUT signal from the diver even if the tender is connected in 4-Wire (Full Duplex) mode. When the tender uses a headset, the SPEAKER SWITCH should be turned off to prevent acoustic feedback. Acoustic feedback can also be avoided by moving the tender away from the 2810-01 by using the Amron Model 2822-28 Remote Walk-and-Talk Module. In this way, the PANEL SPEAKER can allow other members of the diving crew to monitor the dive operation or to communicate to the diver by pressing the PUSH-TO-TALK BUTTON and talking into the speaker.

4.2.3 SETTING THE VOLUME CONTROLS

2-WIRE MODE - Turn power switch to ON, turn speaker switch to ON, and adjust both volume controls to mid-scale. Tender has to depress PUSH-TO-TALK BUTTON in order to talk to diver. Tender and Diver talk to each other during Tender adjusting volume controls as below:

DIVER TO TENDER VOLUME - While diver is talking, tender adjusts this volume control to a comfortable hearing level.

TENDER TO DIVER VOLUME - While tender is talking into the panel speaker and depressing PTT switch, tender adjusts this volume control to a comfortable diver hearing level.

4-WIRE (FULL DUPLEX) MODE -Turn power switch to ON, turn speaker switch to OFF, and adjust both volume controls to mid-scale. Tender to use headset. Tender and Diver talk to each other during Tender adjusting volume controls as below:

DIVER TO TENDER VOLUME - While diver is talking, tender adjusts this volume control to a comfortable hearing level.

WARNING!

To ensure clear communications when using the AUXILIARY AUDIO INPUT, it is critical that the volume level of the external audio device be set at a level below that of the tender's microphone as described above. It is recommended that the tender use the PUSH-TO-TALK BUTTON when talking to the diver as this cuts off the signal from the AUXILIARY AUDIO INPUT

TENDER TO DIVER VOLUME - While tender is talking, tender adjusts this volume control to a comfortable level for the diver. If the AUXILIARY AUDIO INPUT will be used, the volume level of the external audio device should not be higher than the tender's voice.

5 MAINTENANCE AND TROUBLESHOOTING

The following section describes the procedures for checking the operation of your diver communicator, general maintenance procedures, and how to troubleshoot common problems.

5.1 DIVER COMMUNICATOR CHECK PROCEDURES

The following are a series of step-by-step procedures to perform a functional check of your 2810-01 communicator using only a headset. These steps check all communication functions in both 2-Wire and 4-Wire (Full Duplex) mode. If the communicator checks out using these procedures, then any communication problems are probably located somewhere else in the system setup.

5.1.1 FULL DUPLEX (4-Wire) CHECK

This procedure checks the communicator functions in the Full Duplex (4-Wire) mode.

1. Set all volume controls to the mid-scale (halfway) position.
2. Turn the SPEAKER SWITCH off to avoid acoustic feedback.
3. Turn on the communicator and verify the BATTERY CONDITION INDICATOR is on or blinking. If the LED does not come on at all, then replace or recharge the battery. If that does not resolve the problem, then go to the troubleshooting section to determine the cause.

4. Identify the microphone and headset leads. When using an Amron headset, the microphone is the red banana plug and the headset is the black banana plug.
5. Plug the microphone lead into the TENDER MICROPHONE (red) jack and the headset lead into the TENDER HEADSET (black) jack.
6. Don the headset and talk into the microphone. You should be able to hear yourself in the headset. Adjust the DIVER TO TENDER VOLUME control and verify the level can be adjusted to a comfortable level.
7. Move the headset microphone lead to the DIVER MICROPHONE (red) jack. Talk into the microphone. You should be able to hear yourself in the headset. Adjust the DIVER TO TENDER VOLUME control and verify that the level can be adjusted to a comfortable level.
8. Move the headset lead to the DIVER EARPHONE (black) jack. Talk into the microphone. You should be able to hear yourself in the headset.

This completes the check of the Full Duplex (4-Wire) function of the communicator. If at any point in the test you were not able to hear yourself in the headset as indicated by the test, refer to the troubleshooting section to determine the cause.

5.1.2 2-WIRE CHECK

This procedure checks the communicator functions in the 2-Wire mode.

1. Set all the volume controls to the mid-scale (halfway) position.
2. Turn the SPEAKER SWITCH off to avoid acoustic feedback.
3. Turn on the communicator and verify the BATTERY CONDITION INDICATOR is on or blinking. If the LED does not come on at all, then replace or recharge the battery. If that does not resolve the problem, then go to the troubleshooting section to determine the cause.
4. Identify the microphone and headset leads. When using an Amron headset, the microphone is the red banana plug and the headset is the black banana plug.
5. Plug the microphone lead into the TENDER HEADSET (black) jack and the headset lead into the DIVER MICROPHONE (red) jack.
6. Don the headset. Talk into the microphone while pressing the PUSH-TO-TALK BUTTON. You should be able to hear yourself in the headset. Adjust the TENDER TO DIVER VOLUME control and verify that the level can be adjusted to a comfortable level.
7. Unplug the microphone lead. Turn on the SPEAKER SWITCH. Press the PUSH-TO-TALK BUTTON while speaking into the PANEL SPEAKER. You should be able to hear yourself in the headset. Adjust the TENDER TO DIVER VOLUME if necessary and verify that the level can be adjusted to a comfortable level.

8. Plug the microphone lead into the TENDER HEADSET (black) jack. Short the PUSH-TO-TALK JACK (yellow) with a short piece of wire. Talk into the microphone and verify that you hear yourself in the headset. Remove the short. Turn off the SPEAKER SWITCH.
9. Move the microphone lead to the DIVER MICROPHONE (red) jack and move the headset lead to the TENDER HEADSET jack.
10. Talk into the microphone and verify you can hear yourself in the headset. The PUSH-TO-TALK BUTTON should not be pressed. Adjust the DIVER TO TENDER.

5.2 GENERAL MAINTENANCE

The 2810-01 diver communicator is designed to provide years of continuous, failure-free service when properly used and maintained. There are a few important things that the user can do to extend the life of their equipment

1. Handle the diver communicator with care. Do not throw it around or drop it. Select a work area where the communicator and wire connecting to it are out of everyone's way so it is not knocked over.
2. Clean the communicator after use or when needed. If the equipment is on an extended work program, have the tender clean the equipment during slow work periods. Rinse off salt deposits with fresh water. Clean the diver connections with a mild vinegar and water solution using a soft brush. Rinse off the connectors with water after cleaning.
3. When using a rechargeable battery, the battery should be recharged after use or as soon as possible when the BATTERY CONDITION INDICATOR starts blinking.

5.3 RECOMMENDED MAINTENANCE SCHEDULE

The following sections outline the recommended scheduled maintenance for the 2810-01.

5.3.1 DAILY MAINTENANCE

Wipe off any accumulated salt or salt spray on the front panel or connectors using a clean, damp cloth. Pay particular attention to where the various front panel components attach to the panel. Inspect the outer case for any damage.

5.3.2 WEEKLY MAINTENANCE

Wipe off any accumulated salt or salt spray on the front panel or connectors using a clean, damp cloth. Pay particular attention to where the various front panel components attach to the panel. Inspect the outer case for any damage.

- Inspect the PUSH-TO-TALK BUTTON, binding posts and volume controls for smooth operation.
- Inspect the case lid O-ring for any damage and replace if necessary.

5.3.3 6 MONTH CHECK

Wipe off any accumulated salt or salt spray on the front panel or connectors using a clean, damp cloth. Pay particular attention to where the various front panel components attach to the panel. Inspect the outer case for any damage.

1. Inspect the PUSH-TO-TALK BUTTON, binding posts and volume controls for smooth operation.
2. Inspect the case lid O-ring for any damage and replace if necessary.
3. Inspect the front panel gasket for any damage and replace if necessary.
4. Recharge the battery.
5. Perform the 2-Wire and 4-Wire (Full Duplex) system checks as described in sections 5.1.1 and 5.1.2.

5.3.4 YEARLY CHECK

For maximum service life, it is recommended that the diver communicator be sent back to Amron for a yearly check.

5.4 TROUBLESHOOTING

Most problems are usually simple issues that can often be found by careful inspection of the diver communicator, diving umbilical, and diver wiring. The following section will describe the troubleshooting procedure for several common issues. If these sections do not cover your particular issue, it is recommended that the diving umbilical be disconnected from the diver communicator and the check-out procedures in section 5.1.1 be conducted. If the diver communicator passes the check-out procedures then the issue is most likely in the umbilical connections, the umbilical itself, or the wiring of the diver's hat/helmet.

5.4.1 CONNECTION ISSUES

Most diver communicator problems are caused by bad connections. Making good connections will result in years of good communications. For longer life, all connections should be soldered and copper wire must be tinned. It is strongly suggested that dual banana plugs be used topside to provide convenient and secure connections.

All cable splices must be soldered. Splices should be staggered and covered with shrink tubing (preferably shrink tubing with an adhesive sealant) and a general splice cover to protect the connections. Potting the splices to create a reliable splice is preferred but not necessary to create a reliable splice.

5.4.2 LOW BATTERY INDICATION

The BATTERY CONDITION INDICATOR indicates the battery level or state-of-charge by monitoring the battery voltage. The battery voltage can be measured independently using a Voltmeter by measuring the voltage across the EXTERNAL BATTERY JACK. The voltage has to be 9 Volts or greater for the communicator

with rechargeable battery to operate. It is recommended that the communicator be recharged for at least 10 hours if the measured voltage is less than 12 Volts (depending on the age of the battery and the surrounding temperature). If the BATTERY CONDITION INDICATOR indicates a low (blinking LED) or bad (off LED) after charging, then either the battery is bad and needs to be replaced or the charger has malfunctioned.

WARNING!

When changing the battery it is critical that the RED wire be connected to the positive terminal of the battery and the BLACK wire connected to the negative terminal of the battery.

5.4.3 UNIT NOT OPERATING

The most common reason that a diver communicator appears to be dead when the POWER SWITCH and SPEAKER SWITCH are turned on is a bad or loose battery. Check the battery per section 5.2. If the battery is good, then disconnect any diving umbilical and perform the communicator check out procedure per section 5.1.1 & 5.1.2.

If the battery and battery connections appear good and the communicator fails the check-out procedure, then remove the screws holding the front panel. Lift the front panel up carefully as the panel components are connected to a Printed Circuit Assembly (PCA) by a wire harness. Verify that the connectors on the PCA are firmly seated. Check that the wire harnesses are soldered to the various connectors, controls, and speaker. There should be no loose wires in the system. Remove the fuse from the PCA. It is marked FH1 and is a cylindrical component. Verify that the fuse is good by checking the continuity with a multi-meter. If the fuse is open, replace with the same type: 3.15 Amp, 250V, Fast Acting. Close the front panel; re-install the screws and re-test the communicator. If the communicator still appears dead, contact Amron for further assistance.

5.4.4 LOW VOLUME

Check the volume control settings and adjust if necessary. Check the diver connections and verify that the diver and tender are connected as intended. Verify the wires and connector are clean and tight (see section 5.4.1 for additional information). Check the BATTERY CONDITION INDICATOR and test the battery per section 4.1.2 if necessary. If the problem persists, disconnect the diver umbilical and perform the communicator check out procedure per sections 5.1.1 & 5.1.2. If the communicator fails the check-out procedure, contact Amron for further assistance.

If the communicator checks out, then the problem is likely in either the diver umbilical communication cable, the wiring of the diving hat/helmet, or the diver's microphone/earphone.

5.4.5 GARBLED VOICE TO DIVER

The TENDER TO DIVER VOLUME control is set too high. Reduce this control until the voice signal clears. If this does not solve the problem, check the diver's earphone for corrosion or other defect. Replace if necessary. If the tender is using a headset, remove the headset and communicate to the diver by pressing the PUSH-TO-TALK BUTTON and talking into the PANEL SPEAKER. If this solves the problem then the tender headset may be wet or defective. If the tender is using the PANEL SPEAKER to talk to the diver, check the speaker for any accumulated water. Drain the speaker if necessary. If these steps do not solve the problem, then disconnect the diver umbilical and perform the communicator check out procedure per sections 5.1.1 & 5.1.2. If the communicator fails the check-out procedure, contact Amron for further assistance. If the communicator checks out, then the problem is likely in the diver umbilical communication cable. If possible, substitute a known good cable to verify.

5.4.6 GARBLED VOICE TO TENDER

The DIVER TO TENDER VOLUME control is set too high. Reduce this control until the voice signal clears. If this does not solve the problem, check the diver's microphone for corrosion or other defect. Replace if necessary. If the tender is using a headset, remove the headset and listen to the diver using the PANEL SPEAKER. If this solves the problem then the tender headset may be wet or defective. If the tender is using the PANEL SPEAKER to talk to the diver, check the speaker for any accumulated water. Drain the speaker if necessary. If these steps have not solved the problem, then disconnect the diver umbilical and perform the communicator check out procedure per section 5.1.1. & 5.1.2. If the communicator fails the check-out procedure, contact Amron for further assistance. If the communicator checks out, then the problem is likely in the diver umbilical communication cable. If possible, substitute a known good cable to verify.

5.4.7 DIVER CUTS OFF

This is usually caused by an intermittent connection between either the umbilical and the diver communicator or the umbilical and the diver's hat/helmet. The intermittent connection could also be inside the diver's hat/helmet. Check all connections to verify that they are clean and tight. If the problem continues, substitute the communication cable with a known good cable. If this solves the issue, then the communication cable in the original umbilical is damaged and needs to be replaced or repaired. If none of these solutions fixes the problem, contact Amron for further assistance.

5.4.8 FEEDBACK FULL DUPLEX (4-Wire) MODE

There are two forms of feedback that can affect the 2810-01: acoustic feedback and cable crosstalk. Acoustic feedback occurs when an active microphone is close enough to pick up and amplify the signal from a speaker or earphone. The required distance between the microphone and speaker/earphone is dependent on the volume setting and the amount of acoustic isolation. For example, a tender headset

left sitting on a work table may cause acoustic feedback. When the tender dons the headset at the same volume level, the acoustic feedback will no longer occur. The tender's head provides acoustic isolation between the microphone and earphone of the headset. The same is true for the diver's microphone and earphone.

To troubleshoot acoustic feedback issues first determine the source. One way to quickly determine the source of the acoustic feedback is to cover each active microphone with your hand, one at a time. Another method is to adjust the volume controls one at a time. The volume control that stops the feedback indicates the source. For example if the TENDER TO DIVER VOLUME control stops the feedback, then the problem is likely in the diver's hat/helmet. Common sources are feedback between the tender's headset microphone and the PANEL SPEAKER. If the tender wants to operate with the headset and leave the PANEL SPEAKER on, Amron recommends the tender move away from the communicator by using the Amron Model 2822-28 Remote Walk-and-Talk Module. This module provides an "extension" cord for the tender headset allowing the tender to operate the communicator the required distance as needed.

Crosstalk is caused by signal leakage between the microphone and earphone wires in the umbilical cable. Amron recommends only a two pair twisted shielded type cable. With all the wires open (not connected), the resistance between any two wires should be greater than 10 Meg-Ohms. Over time, the cable can be damaged and this resistance drops to the point that crosstalk can occur. When this occurs, the communication cable in the umbilical should be replaced. For a temporary solution, you can try swapping the position of the diver earphone wires on the DIVER EARPHONE jack. If you are using a banana plug, simply unplug the diver earphone and rotate by 180 degrees before reconnecting. If this does not solve the problem and the umbilical cannot be immediately replaced, then operate in 2-Wire mode until a replacement umbilical can be used. Amron strongly recommends the use of the Amron CC1 communication cable. It has been specially designed for clear communications and long service life.

5.4.9 PUSH-TO-TALK DOES NOT WORK

If used, check the connection to the handheld microphone. A common issue is that the yellow banana plug is not properly seated in the PUSH-TO-TALK JACK. If the tender is using the PANEL SPEAKER as the microphone with the PUSH-TO-TALK BUTTON, make sure the SPEAKER SWITCH is turned on. If neither of these solves the problem, there could be a broken wire inside the diver communicator. Open the front panel and inspect as described in section 5.4.1. If that does not resolve the problem then contact Amron for further assistance.

6 DRAWINGS

The following drawings illustrate the electrical and mechanical details of the diver communication unit. The corresponding parts lists for each drawing are detailed in the parts lists section, or are included as part of the drawing. All drawings are at their current revision level as of the date of printing. Amron reserves the rights to revise the documentation without notification.

6.1 2810-01 CHASSIS PARTS LOCATOR

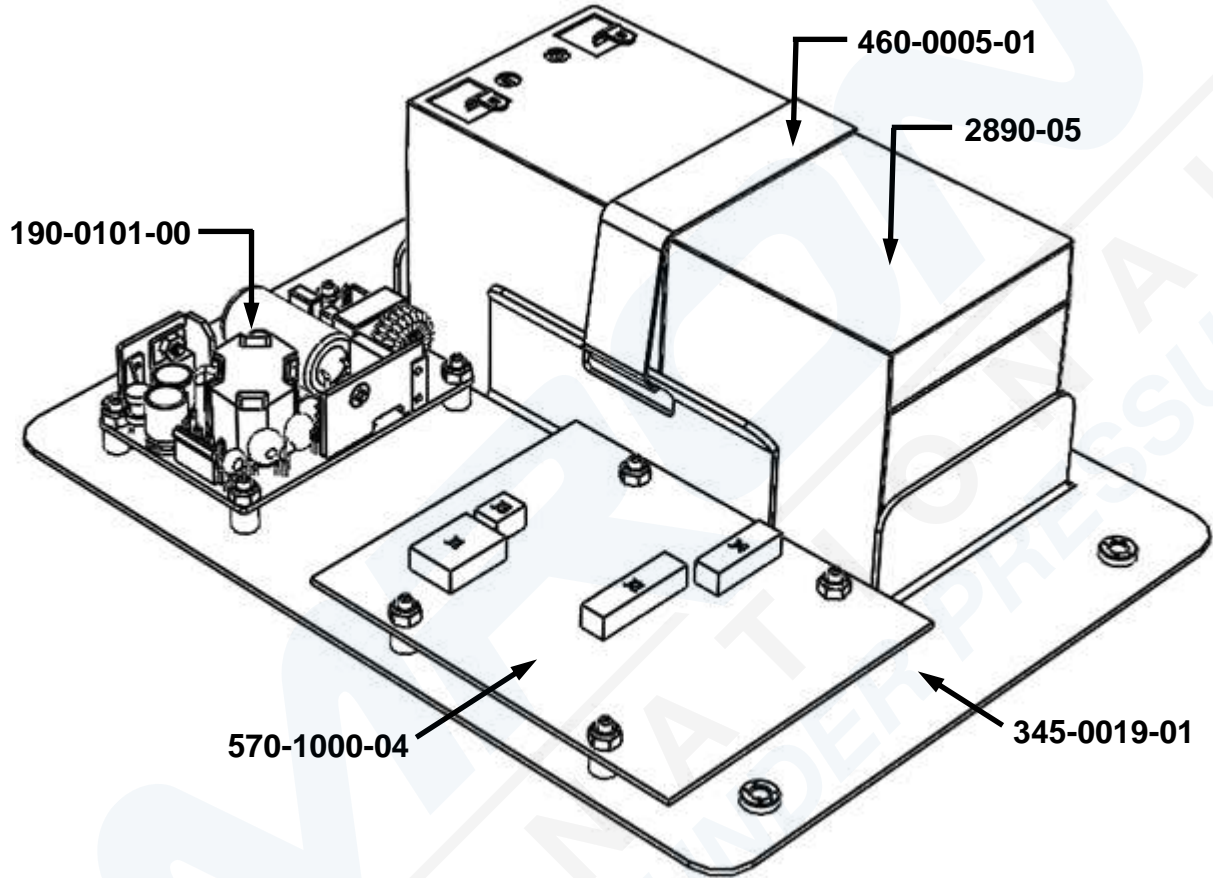

6.2 2810-01-400 FRONT PANEL PARTS LOCATOR

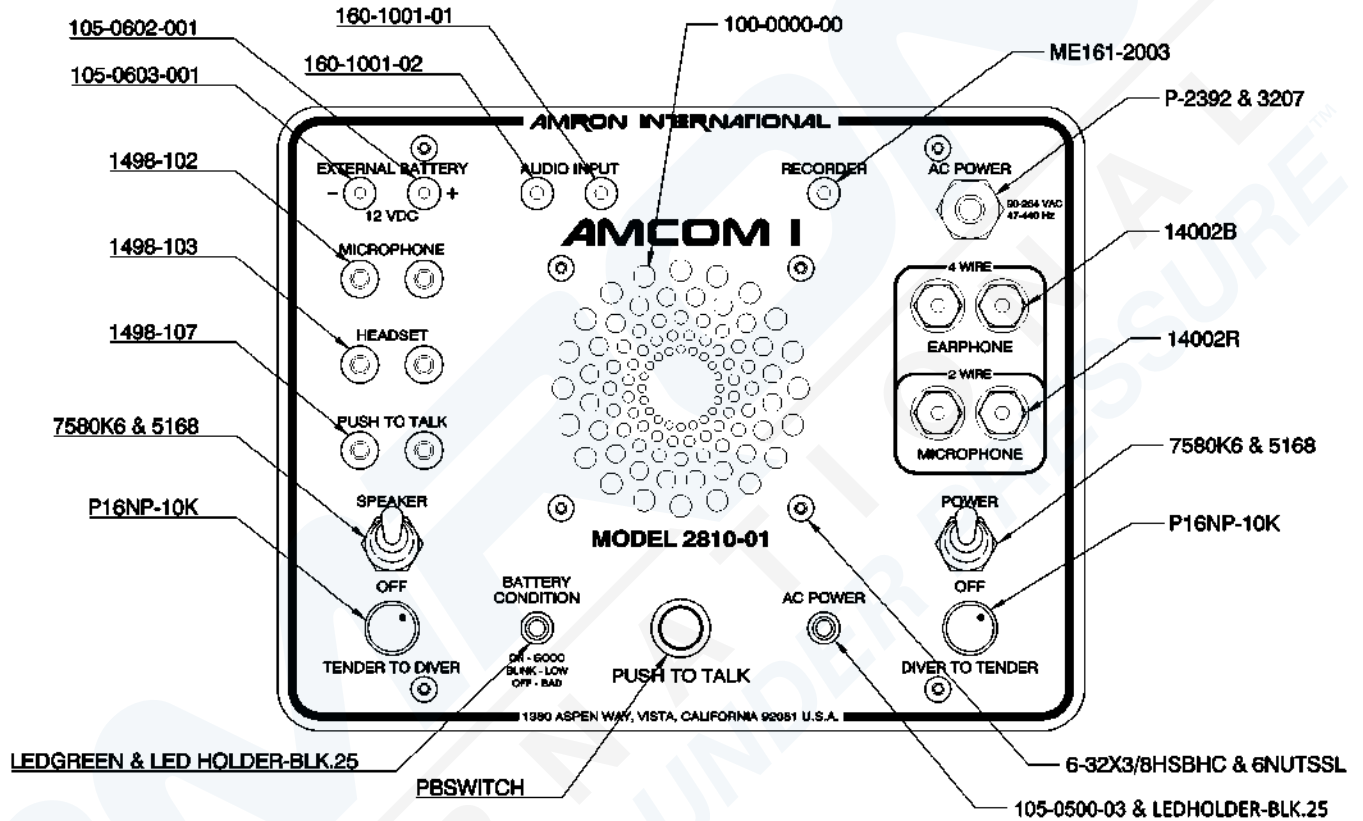

7 PARTS LISTS

The parts lists include both mechanical and electrical parts. The following information will be useful in interpreting data which is not self-explanatory.

REVISIONS

The parts lists in this manual are for the current model of diver communicator as of the printing date.

To Order Replacement Parts Contact:

Amron International, Inc.
 1380 Aspen Way, Vista, California, 92081 U.S.A.
 Telephone: (760) 208-6500 Fax: (760) 599-3857
 Email: sales@amronintl.com
 Web: www.amronintl.com

When ordering replacement parts, you should give as much information as possible to enable us to supply the correct part. This information should include the part number, description, reference designator, value, radio model number, and serial number. Failure to provide sufficient information may hinder our ability to fill your parts orders promptly and correctly.

7.1 MODEL 2810-01 CHASSIS COMPONENTS

Part Number	Description
570-1000-04	P.C. Card Assembly, Model 2810-01
2890-05	Rechargeable 12V Battery
190-0101-00	Power Supply
460-0005-01	Battery Strap
345-0019-01	Mounting Bracket

7.2 2810-01-400 FRONT PANEL COMPONENTS

Part Number	Description
2810-01-400	Complete Front Panel Assembly with Wire Harness
100-0000-00	Speaker
105-0602-001	Jack Tip Red
105-0603-001	Jack Tip Black
14002B	5-Way Binding Post Black
14002R	5-Way Binding Post Red
1498-102	Jack Banana Red
1498-103	Jack Banana Black
1498-107	Jack Banana Yellow

Part Number	Description
160-1001-01	Jack, RCA Red
160-1001-02	Jack, RCA White
5168	Seal Half Boot Toggle Gray
7580K6	Switch Toggle SPST
LEDGREEN	Led Green, Battery Condition
LEDHOLDER-BLK.25	Mounting Clip for LED
ME161-2003	Jack Phono
P16NP-10K	Potentiometer 10k Ohm with Knob
P-2392	Power Cord
PBSWITCH	Switch Sealed Push-Button Mom
105-0500-03	LED Green, AC Power

7.3 2810A-FS-02 FIELD SPARES KIT

Part Number	Description	Quantity
105-0602-001	Jack, Tip Red	1
105-0603-001	Jack, Tip Black	1
14002B	5-Way Binding Post Black	2
14002R	5-Way Binding Post Red	2
1498-102	Jack, Banana Red	2
1498-103	Jack, Banana Black	2
1498-107	Jack, Banana Yellow	2
0034.6019	Fuse 3.15A/250V Micro Quick	1
5168	Seal, Half boot Toggle Gray	1
7580K6	Switch, Toggle SPST	1
LEDGREEN	LED Green	1
LEDHOLDER-BLK.25	Mounting Clip for LED	1
P16NP-10K	Potentiometer, 10k Ohm with knob	1
PBSWITCH	Switch, Push Button, Sealed	1

8 LIMITED WARRANTY AND SERVICE POLICY

Amron International, Inc.

LIMITED WARRANTY & SERVICE POLICY

LIMITED WARRANTY

AMRON INTERNATIONAL, INC., (Amron) warrants that its manufactured products are free from defects in material and workmanship under normal use and service for a period of one year from date of shipment as described in Amron's literature covering this product. Oxygen Treatment Hoods and accessories are excluded and limited to 90 days. Amron's obligation under this warranty is limited to the repair or replacement, at Amron's option, of defective material. This warranty shall not cover defects which are the result of misuse, negligence, accident, repair or alterations.

SERVICE POLICY

For technical assistance or to request a repair, please complete one of the following:

- *Amron Communicator Repair* : <https://www.amronintl.com/communicator-repair-form>
- *Repair Request* (all other products): <https://www.amronintl.com/repair-form>
- Call (760) 208-6500, Monday – Friday, 8 a.m. to 5 p.m. PST.

Both MODEL NO. and SERIAL NO. are required fields to be entered on the *Amron Communicator Repair Request* form and can be found on the products identification label as shown below.

“Sample” Product Identification Label



Do not return any product without obtaining a RMR (Return Materials Request). Detailed return instructions will be provided at the time of request.

1380 Aspen Way, Vista California 92081-8349 U.S.A
Phone: (760) 208-6500 Fax (760) 599-3857
Email: sales@amronintl.com Web: www.amronintl.com