

Instruction Manual
for
Amron International, Inc.

**Model 8225-HP & 8225-HP2 AMCOMMAND II
Two Diver Air Control Systems**

S/N: _____



1380 Aspen Way, Vista California 92081-8349

United States of America

Phone: (760) 208-6500

Fax (760) 599-3857

email: sales@amronintl.com

web: www.amronintl.com

This manual and the information contained herein are provided for use as an operation and maintenance guide. No license or rights to manufacture, reproduce, or sell either the manual or articles described herein are given. Amron International, Inc. reserves the right to change specifications without notice.

TABLE OF CONTENTS

1. SPECIFICATONS.....	1
1.1 Air Control	1
1.2 Depth Monitoring (Pneumo).....	2
1.3 Communications	2
1.4 Enclosure	3
2. GENERAL INFORMATION.....	4
2.1 Air Control	4
2.2 Depth Monitoring.....	4
2.3 Low Pressure Alarm Module	5
2.4 Communications	5
3. SAFETY AND REGULATIONS	6
3.1 Diving Safety and Regulations	6
3.2 Personnel Requirements.....	7
3.3 Air Supply Requirements	8
3.4 Calibration, Service and Inspection	9
4. OPTIONS.....	10
4.1 Model 2821-28 Walk-and-Push-to-Talk (2-Wire Operation)	10
4.2 Model 2822-28 Remote Walk-and-Talk (4-Wire Operation)	10
4.3 Model 2460-28 Headset.....	10
4.4 Model 2829-11 Wireless Kit with Case	10
4.5 Model 2829-04 Wireless Headset.....	10
4.6 Model 2405-28 Hand Held Microphone	10
4.7 Model HAS-300D 300 Bar DIN Adapter.....	10
4.8 Heating Element.....	10
5. WARRANTY & SERVICE POLICY.....	11
5.1 Limited Warranty	11
5.2 Service Policy.....	11
6. CONTROLS & CONNECTIONS	12
6.1 Air Control	12
6.2 Air Control Front Panel, Model 8225-HP	14
6.3 Depth Monitoring.....	15
6.4 Low Pressure Alarm.....	15
6.5 Pneumo Front Panel, Model 8225-HP	16
6.6 Communications	17
6.7 Communicator Front Panel, Model 2825A-8225.....	21
7. PRE-DIVE PROCEDURES	22
7.1 Pre-Dive Set-Up	22
7.2 Pre-Dive Check Out	22
7.3 Pre-Dive Pneumo Test.....	23
7.4 Pre-Dive Testing Communications.....	24
7.5 Connecting Diver Umbilical	24
7.6 Low Pressure Supply	24

8. OPERATING PROCEDURES.....	26
8.1 Low Pressure Breathing Air (Primary Supply)	26
8.2 High Pressure Breathing Air (Primary Supply).....	26
8.3 Pre-Operation Checklist	27
8.4 Pneumo Readings.....	27
8.5 Diver Communications	29
8.6 2-Wire Operation (Refer to Figure 3)	29
8.7 Diagram, 2-Wire Set-Up Instructions (Figure 3).....	31
8.8 FULL DUPLEX (4-Wire) Operation (Refer to Figure 4)	32
8.9 Diagram, FULL DUPLEX 4-Wire connection Model 2825-8225 (Figure 4)	33
8.10 FULL DUPLEX (4-WIRE) – WHAT, WHY AND HOW.....	34
9. THEORY OF OPERATION	38
9.1 Flow Diagram, Model 8225-HP	41
9.2 Electrical.....	42
9.3 Functional Block Diagram, Model 2825-8225	45
10. MAINTENANCE	46
10.1 Review of Scheduled Maintenance.....	46
10.2 Scheduled Maintenance.....	46
11. TROUBLESHOOTING AND REPAIR.....	48
11.1 General Information	48
11.2 Air Control	49
11.3 Depth Monitoring	51
11.4 Diver Communications	51
11.5 Problems and Their Possible Causes	53
12. REFERENCE MATERIAL.....	56
12.1 Diving Log, U.S Navy (Chart).....	56
12.2 Repetitive Dive Worksheet.....	57
12.3 No Decompression Limits	58
12.4 Gauge Pressure for Depth of Seawater & Fresh water	59
12.5 Equivalent Depths of Seawater & Freshwater	60
13. DRAWINGS.....	61
13.1 Parts Locator, Model 8225-200 (pneumo Front Panel)	62
13.2 Parts Locator, Model 8225-200 (Pneumo Back Panel)	63
13.3 Parts Locator, Model 8225-400 HP (Air control Front Panel)	64
13.4 Parts Locator, Model 8225-400 HP (Air Control Back Panel).....	65
13.5 Parts Locator, Model 8225 HP2 (Air Control Front Panel).....	66
13.6 Parts Locator, Model 8225-400 HP2 (Air Control Back Panel).....	67
13.7 Parts Locator, Model 2825A-8225-28A (Diver Communications).....	68
13.8 Parts Locator, Model 8000-0201 (Regulator).....	69

14. PARTS LISTS	70
14.1 AMCOMMAND II Air Control System, Model 8225-HP.....	71
14.2 AMCOMMAND II Air Control System, Model 8225-HP2.....	71
14.3 8225-200 Pneumo Panel Assembly.....	72
14.4 8225-400HP Air Control Panel Assembly, Model 8225-HP	73
14.5 8225-400HP2 Air control Panel Assembly, Model 8225-HP2.....	74
14.6 8225-500 Yoke/Hose Assembly.....	75
14.7 26-1512-26-277 Regulator, Pressure Reducing	76
14.8 2825A-8225-400 Front Panel Assembly.....	77
14.9 Recommended Spare Parts	78
15. REPAIR & CALIBRATION LOGS	79
15.1 Repair and Maintenance Log for Model 8225-HP(2)	79
15.2 Gauge Calibration Log Model 25545-23B11-HDP.....	80

1. SPECIFICATONS

1.1 Air Control

1.1.1 High Pressure Input

Input Pressure Range	500-3000 PSI with standard CGA850 Yoke Connections	
	***500-4500 PSI with optional 300 Bar DIN Adapters	
Inlet Valve (Source Select)		2
Gauge - 0-6000 PSI	Accuracy +/- 1.5%	
Check Valve, prevents reverse inlet flow.....		2
Input Filter, In Line Pre Regulator.....	50 Micron	
CGA850 Yoke connections with 6 ft. high-pressure hose whips (standard)		2

** Available with optional 300 Bar DIN Adapters, Amron Part No. HAS-300D ***

1.1.2 High Pressure Regulator, Tescom

Outlet Pressure Range	0-265 PSI	
High Flow	Cv = .24	
Max Pressure.....	4500 PSI	

1.1.3 Low Pressure Input, with Check Valve

Max Pressure	285 PSI	
Inlet Connection (#6 JIC)		1
Diver Outlet Connection, (O2 Fitting).....		2
Diver Outlet Valve		2
Air Pressure Gauge, 0-600 PSI	Accuracy +/- 1.5%	
Over Pressure Relief Valve Set Pressure.....	285 PSI	

1.1.4 Universal Storage lock – CGA850 Yoke & 300 Bar DIN

HP hoses and CGA850 yokes or optional 300 BAR DIN connections are secured to universal storage blocks mounted on air control panel located inside of unit.

1.1.5 Panel

Material	Stainless Steel	
Powder Coating	Black Textured Semi-Gloss Polyester	
Silkscreen Graphics	Red, White & Blue	

1.2 Depth Monitoring (Pneumo)

1.2.1 Pneumo Gauge

Mirrored Scale, 6 Inch..... 2
 Range Dual Scale 0-250 FSW/0-76 MSW
 Divisions..... 1 Foot
 Accuracy 0.25% of Full Scale

1.2.2 Pneumo Valve

Regulating Valve, KEL-F Seat 2

1.2.3 Outlet Connection

O2 Fitting Chrome Plated Brass 2

1.2.4 Low Pressure Alarm

Audio Range, 22.5-125 PSI Factory set at 100 PSI

1.2.5 Panel Material

Material Aluminum
 Powder Coating Black Textured Semi-Gloss Polyester
 Silkscreen Graphics Yellow

1.3 Communications

1.3.1 AMCOM II, Model 2825A-8225 2-Diver Communicator

Operating Voltage 12 V DC
 Power Rechargeable Battery
 or External Power 12 VDC
 Operating Time Nominal 60 Hour
 Charger 110/220 Volt
 Frequency Response 300-7500 Hz
 Audio Power..... 12 Watt
 Panel..... Black Powder Coat over Stainless Steel with White Silkscreen Graphics

1.4 Enclosure

1.4.1 Case Material

Pressure molded fiberglass, with aluminum and or stainless steel hardware.
Includes carrying handle, latches, and stay hinge to lock unit in open position (upper section is locked upright in respect to lower section).

1.4.2 Case

Lid closed 20" W x 14" D x 12" H
Lid Open 20" W x 14" D x 21" H
Weight: Approximately 70 lbs.
Color: International yellow

2. GENERAL INFORMATION

The AMRON AMCOMMAND II Model 8225-HP & 8225-HP2 is a portable self-contained two-diver high and low pressure air control, communication and depth monitoring (pneumo) system, for surface supplied diving operations. The system is designed to provide a central control point for the supply of breathing air to the divers, monitor the diver's depth, and provide two-way communications between the divers and the surface. The system is housed in a durable pressure fused fiberglass case, which provides a convenient, compact, rugged, professional system.

2.1 Air Control

The Air Control Section consists of two high-pressure inputs, a single low-pressure input, and two-diver air connections.

2.1.1 Standard 3000 PSI MAX Input

Model 8225-HP & HP2 comes standard with 2 each CGA850 yokes attached to 6-foot long HP hoses. The CGA850 yoke limits the maximum input pressure to 3000 PSI

2.1.2 Optional 4500 PSI MAX Input

Installing the 300 Bar DIN Adapters, Amron Part No. HAS-300D, will increase the maximum input pressure limit to 4500 PSI. Simply remove CGA850 yoke nut and yoke from bleeder body, screw on 300 Bar DIN adapters, and tighten with a wrench

Each input has a shut-off valve and 0-6000 psi gauge.

Check valves provide protection against back flow of air from a full bottle to an empty, when switching HP bottles. High-pressure air is reduced to desired low pressure via a Tescom adjustable regulator. The input to the regulator is protected against contamination by a 50-micron filter. Regulator output pressure is adjustable over the range of 0 to 285 psi; a 2 1/2" 0 600 PSI gauge monitors the output pressure. The unit has an over pressurization relief valve, factory set to 285 psi.

The low-pressure input is #6 JIC (3/8), and has a check valve to permit simple switch over from low-pressure air to high-pressure air.

2.2 Depth Monitoring

The diver's pneumo connection is an O2 type fitting; pneumo valves are regulating type. Pneumo gauges are 6" high, precision 0.25% of full-scale accuracy, dual scale 0 250 FSW/0-76 MSW with one foot increments. Gauge protectors are provided for each pneumo gauge.

2.3 Low Pressure Alarm Module

Low Pressure Alarm Module supplies a loud audio signal to alert the operator when a diver's air pressure falls below a preset limit of 100 PSIG.

2.4 Communications

The diver communication system is based on the field proven AMRON Model 2825. The unit is powered from internal, rechargeable gel-cell batteries; battery charger provided. Operating time from fully charged battery is approximately 60 hours. Unit can also be operated from an external 12 V DC source, via charger jacks on the front panel. The communicator has a unique battery condition indicator. Steady GREEN light indicates battery voltage level is good. Blinking GREEN light indicates battery voltage is approaching a low level (approx. 2-4 hours of operation remain). Steady RED light indicates battery voltage is below the level necessary to guarantee proper operation.

WARNING: When Battery Condition indicator is steady RED light, communication will stop. The battery condition indicator also functions in the same manner when operating from an external power source.

Possibly the most useful feature of the AMCOMMAND communicator is the ability to operate the unit remotely. This feature allows the use of a hand-held, push-to-talk microphone (included), or a walk and talk type module (optional). This allows the tender (operator) to move about and still maintain contact with the divers.

The use of the noise canceling push-to-talk microphone automatically disconnects the speaker when talking to the divers, cutting out the majority of the background noise which greatly improves the intelligibility of communications.

The communicator provides 12 watts voice power. This power level provides the volume necessary to communicate clearly even under difficult conditions. Standard controls include: power on/off, tender volume, diver volume, speaker on/off, 5-way binding post diver input, push-to-talk switch, headset/microphone jack, and remote push-to-talk jacks.

2.4.1 28A Wireless Tender Option

Models 8225-HP/28A & 8225-HP2/28A Amcommand II comes with the Amron 2-Diver Deluxe Communications System with Wireless Tender. This feature allows the tender (operator) to be completely mobile around the dive sight while still remaining in constant contact with the divers. The wireless tender is a full duplex (FULL DUPLEX) system. The system comes complete with a built in transceiver module with antenna and one wireless headset with clip-on belt module. The system allows unlimited headsets for listen only. The transceiver operates at a frequency of 2.40 to 2.46 GHz using frequency modulation. They have a range of 120 yards (110 meters) with clear line-of-sight.

3. SAFETY AND REGULATIONS

Safe diving does not happen by accident. There are few occupations in the world which require such a broad range of knowledge and training as diving. There are many diverse factors which can affect diving safety, i.e. planning, weather, equipment, location, water conditions, as well as the type of work being done. The single most important factor in eliminating accidents is planning and attention to detail. Diving knowledge, training and experience are fundamental elements needed to execute a safe dive.

The following reference materials are recommended as sources of information for running a safe diving operation:

1. U.S. Department of Labor, OSHA Regulations 1910.401 Sub-part T– Commercial Diving Operations.
2. U.S. Navy Diving Manual.
3. Divers Handbook of Underwater Calculations.

3.1 Diving Safety and Regulations

3.1.1 Diving Regulations

Several codes and regulations cover diving operations and procedures. In the United States most commercial diving operations are covered by the OSHA (Occupational Safety and Health Administration) regulations, or individual state regulations, which are adopted from the federal regulations, and made a part of the civil code.

While government agencies are exempt from OSHA regulations, they generally fall under other regulations, which are similar or stricter than OSHA. If they are completely exempt, they must still abide by the procedures for operating a safe dive.

While no agency (within the U.S., for commercial diving operations) tests or approves equipment for use, they do establish minimum standards which should be followed. The suitability of a given piece of equipment for a particular task is left to the supervisor of the dive. The following information is extracted from the OSHA regulations for commercial diving operations.

NOTE: The information is not presented as a direct or complete quotation, but rather as our interpretation of the regulations. Each diving supervisor should obtain a copy of these regulations for their own use.

Copies of the complete section of Commercial Diving Operations are available from Amron International for a nominal charge.

WARNING: DO NOT USE THE AMCOMMAND II FOR THE FOLLOWING:

- Mixed gas diving operations with an oxygen level greater than 25%.
- Oxygen or oxygen enriched breathing mixtures above 25%.

The AMCOMMAND II is not designed or intended for these applications.

3.2 Personnel Requirements

1. Each dive team member shall have the experience or training necessary to perform assigned tasks in a safe and healthful manner. The person operating the AMCOMMAND II must be trained in the proper operating procedures and emergency operating procedures.
2. It is the responsibility of the designated person in charge of the diving operation to be on site at all times. He is responsible for all aspects of the diving operation affecting the health and safety of dive team members.
3. The dive shall be terminated when:
 - A diver requests termination.
 - A diver fails to respond to instructions.
 - Diver communications are lost and cannot be re-established quickly.
 - A diver begins to use diver carried back-up breathing air or location reserve breathing air.
 - Operational conditions deteriorate to a point where safe diving cannot be guaranteed.

3.3 Air Supply Requirements

WARNING

Regardless of the type of air supply being used for surface supplied diving; the diver must always have a back-up supply of air. Generally this is in the form of a bailout bottle. The back-up air supply must be adequate to return the diver to the surface; if the dive requires in-water decompression, this must be accounted for also.

1. The diver's air supply may originate from a low-pressure air compressor, high-pressure air cylinders, or a combination of both. Regardless of the source, the air must meet certain established standards of purity and must be supplied in an adequate volume for breathing.
2. The air supply requirements depend upon the specific factors of each dive such as depth, duration, level of exertion, and type of diving system (helmet/hat) being used. It is the dive supervisor's responsibility to ensure that an adequate supply of air is available and on site for the planned dive. This includes sufficient back up air to safely return the diver to the surface in the event the primary supply of air is lost.
3. Low-pressure compressors used for breathing air should be specifically designed for diving. Compressors used to supply air to the divers shall be equipped with a volume tank which has a check valve on the inlet side, a pressure gauge, relief valve, drain valve, and a proper filtration system. The output of the air compressor system shall be tested for air purity every 6 months by means of an air sample.
4. Air compressor intakes shall be located away from and up wind of areas containing exhaust or other contaminants.
5. **NOTE: OSHA regulations require** a decompression chamber capable of recompressing the diver at the surface to a minimum of 165 FSW (6 ATA) shall be available at the dive location for a surface supplied air diving to depths deeper than 100 FSW.

3.4 Calibration, Service and Inspection

1. Each depth gauge shall be dead weight tested or calibrated against a master reference gauge every 6 months or if there is a discrepancy greater than two percent (2%) between any two equivalent gauges.
2. Each equipment modification, repair, test, calibration, or maintenance service shall be recorded by means of a tagging or logging system, and include the date and nature of work performed, and the name of the person performing the work. For your convenience a repair service log is provided at the end of this manual.
3. Equipment Inspection; Prior to each dive, the equipment shall be inspected and checked to ensure that it is in proper working order.

4. OPTIONS

4.1 Model 2821-28 Walk-and-Push-to-Talk (2-Wire Operation)

AMRON headset extension (remote walk and talk), with push-to-talk belt module, jacks for headset, 25 feet 1/4" O.D. cable (Use with Model 2460 28 headset with boom microphone).

4.2 Model 2822-28 Remote Walk-and-Talk (4-Wire Operation)

AMRON headset extension (remote walk and talk), with belt module, jacks for headset, 25 feet 1/4" O.D. cable (Use with Model 2460 28 headset with boom microphone).

4.3 Model 2460-28 Headset

Headset with boom microphone and color-coded dual banana plugs to mate to color-coded inputs on Amron communicators and accessory items.

4.4 Model 2829-11 Wireless Kit with Case

Wireless kit comes standard with a remote tender transceiver, wireless headset, wall charger, and case.

4.5 Model 2829-04 Wireless Headset

Wireless Headset with single ear muff and boom microphone. Full Duplex, includes voice-actuated transmitter.

4.6 Model 2405-28 Hand Held Microphone

Noise Canceling, Hand Held Push-to-Talk Microphone.

4.7 Model HAS-300D 300 Bar DIN Adapter

Converts a standard Amron CGA850 Yoke (3000 PSI) to 300 Bar DIN (4500 PSI) use.

4.8 Heating Element

Optional heating cable is 18 ft. long and is wrapped around the high pressure input and regulator section located on the backside of manifold panel; the standard plug connection 120 VAC heater is located on the front panel for ease of use; lower case is insulated with closed cell foam to help protect against severe weather conditions as an added safety feature, a GFCI in-line cord set is supplied.

5. WARRANTY & SERVICE POLICY

5.1 Limited Warranty

Amron warrants that its manufactured products are free from defects in material and workmanship under normal use and service, as described in all literature covering the products for a period of 90 days from date of shipment. Amron's obligations under this warranty are limited to the repair of, or replacement of materials at Amron's discretion. This warranty shall not cover defects which are the result of misuse, negligence, accident, repair, or alterations.

5.2 Service Policy

For technical assistance or to request a repair, please call (760) 208-6500, Monday – Friday, 8 a.m. to 5 p.m. PT. Have the model number and serial number handy and be prepared to offer as much information as possible about the problem.

Please do not return any product without obtaining a return authorization number. Detailed instructions will be provided at the time of request.

6. CONTROLS & CONNECTIONS

Before using the AMCOMMAND II Model 8225-HP or 8225-HP2, familiarize yourself with its operating controls and connections. For simplicity, the controls and connections are divided into three categories. The categories are Air Control, Pneumo, and Communications.

6.1 Air Control

The Air Control section consists of a high-pressure section and a low-pressure section. The system is designed to supply breathing air to a diver through an umbilical. This is known as surface supplied diving. The air the divers are breathing is supplied from the surface.

6.1.1 High-Pressure

Accepts breathing air from SCUBA bottles or any other suitable source, i.e. high-pressure flasks. The pressure is reduced to a level suitable to the needs of the diver via a pressure-reducing regulator. The pressure required by the diver is determined by the type of helmet/hat being used and the depth the diver is working at. The general rule of thumb is bottom pressure plus over-bottom pressure required for a given type of diving helmet / hat. Consult your diving helmet / hat manufacture/manual for the requirement of the helmet / hat you are using.

The High-Pressure section has two inputs, complete with high-pressure hose whips, CGA850 SCUBA bottles yokes, and pressure reducing regulator.

6.1.2 Standard 3000 PSI MAX Input

All models come standard with 2 each Amron CGA850 yokes attached to 6-foot long HP hoses. The CGA850 yoke limits the maximum input pressure to 3000 PSI.

6.1.3 Optional 4500 PSI MAX Input

Installing the 300 Bar DIN Adapters, Amron Part No. HAS-300D, will increase the 8225-HP and 8225-HP2 to a maximum input pressure limit to 4500 PSI. Simply remove Amron CGA850 yoke nut and yoke from bleeder body, screw on 300 Bar DIN Adapter and tighten with a wrench

1. Source select inlet valve handles are color coded Red and Blue to correspond to the hose whips which are also color-coded Red and Blue. This helps the operator identify which valve controls which tank. For maximum airflow, turn handle counter clockwise four (4) full turns. To shut-off valve, turn handle clockwise until it stops.
2. Inlet gauge reads actual input pressure of air source. Gauge pressure range is 0-6000 psi; accuracy is 1-1/2% of full scale.
3. Check valves (HP section) prevent input air from one source flowing into a second lower pressure source when both source valves are open. This simplifies the switch over from one SCUBA bottle to another. **NOTE:** If both source valves are left open with full bottles the bottles will be drawn from equally.

4. The Amron CGA850 input yokes are standard with bleed valves and color-coded 6-ft. high-pressure hose whips. The CGA850 input yokes are limited to maximum pressures of 3000 PSI and fit standard SCUBA bottle valves.
5. A pre-regulator filter prevents debris from contaminating the regulator. Filter element is 50 micron.
6. High pressure TESCO regulator(s) reduce pressure of incoming air from high-pressure bottles to a level required by diver's helmet / hat. To increase the diver's air pressure, turn knob clockwise to desired setting. To decrease the diver's air pressure, turn knob counter clock-wise. **NOTE:** Regulator is a non-venting type; in order to reduce the set pressure, air must be flowing through the regulator.

6.1.4 Low-Pressure

The Low-Pressure section consists of an LP input, low pressure output of regulator, LP gauge, and diver connection. A small portion of the LP air is also used when diver depth measurements are made.

LP input accepts breathing air from a low-pressure source i.e., a low pressure diving air compressor. **Note:** The low-pressure section does not regulate the air pressure to the diver. The compressor must be set to provide the proper pressure to the diver.

Breathing air from the low-pressure side of the regulator or the low-pressure input is routed to the diver's breathing air connections. A portion of the low-pressure air is used by the pneumo section for diver depth measurements.

1. Low-pressure input, #6 JIC type fitting. (O₂ type fitting available).
2. Low-pressure check valve prevents the back flow of air from the HP regulator output into the LP air source. This also permits simple switch over from LP to HP air
3. 1/4 Turn ball valve controls flow of air to diver. Ball valve permits unrestricted flow.
4. Divers air supply gauge reads air pressure to divers, 0-600600 PSI.
5. Divers air supply outlet connection, O₂ (oxygen) type fitting. (37° JIC optional).
6. Pressure relief valve, factory set for 285 PSI, vents excess pressure to atmosphere. Vent is located between diver output connections.

6.2 Air Control Front Panel, Model 8225-HP

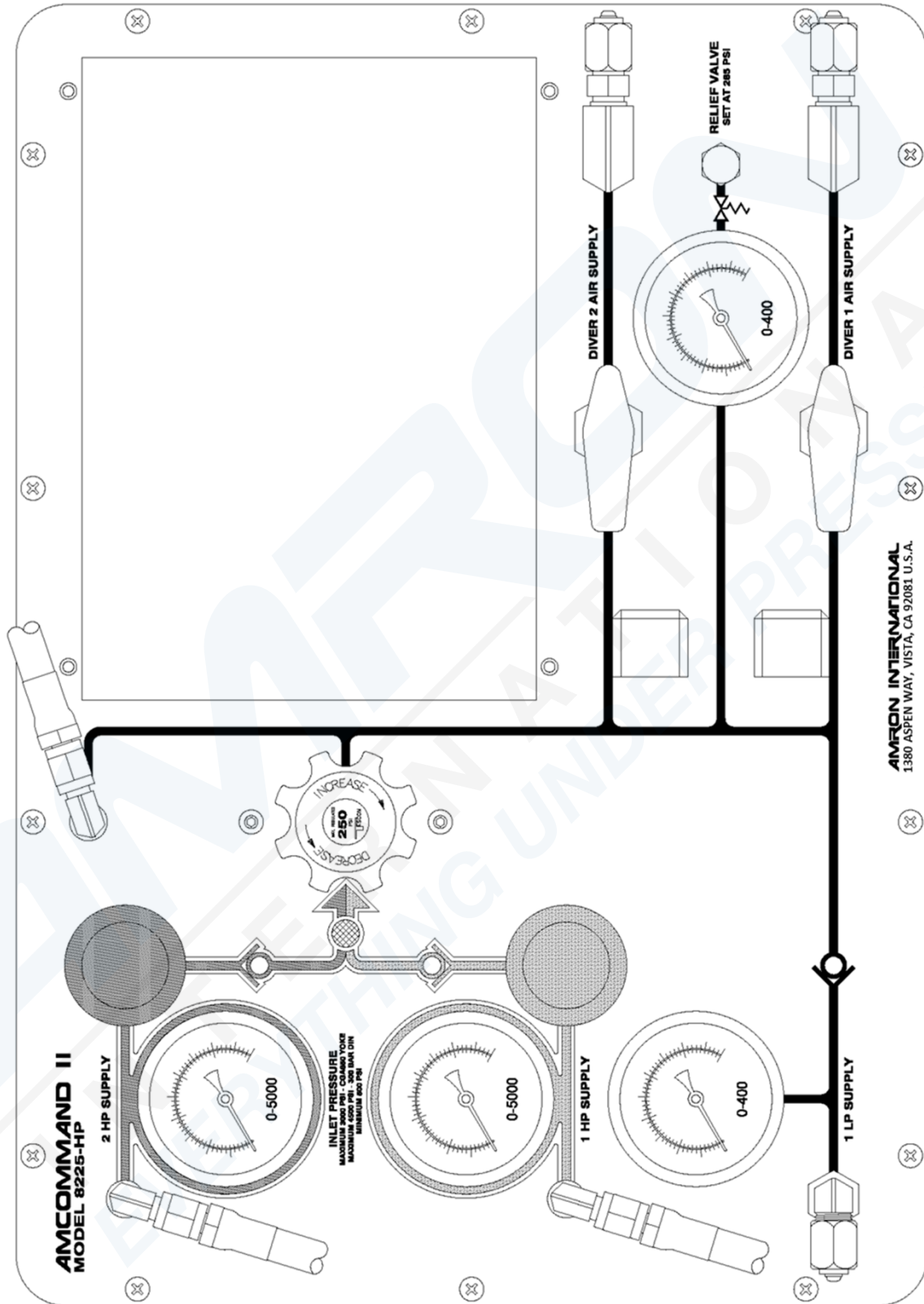

6.3 Depth Monitoring

The Pneumo Fathometer section is used to measure the diver's depth. Pneumo readings are made by pressurizing the diver's pneumo hose. Air is forced through the pneumo hose until all water is displaced. The air is then shut off and the pressure is read on a high accuracy gauge calibrated in FSW (feet of seawater). See Section 8, Page 33, Par. 12 for details. The system components are:

1. Diver pneumo valve (yellow handle) controls the air supply to the pneumo Fathometer system, one for each diver.
2. Pneumo gauge, dual scale 0-250 FSW/0-76 MSW, mirrored scale, 6 inch, high precision, 0.25% of full scale accuracy, one for each diver.
3. Diver pneumo outlet connections are O2 (oxygen) type fittings. (37° JIC fitting optional).

6.4 Low Pressure Alarm

Monitors the divers air pressure. Alarm is factory set to 100 PSI, when pressure drops below the set point the audio alarm is turned on.

1. ON/OFF switch turns alarm on or off as desired.
2. Audio transducer emits audio tone at 2900 Hz at a level of 90 dB.
3. Pressure switch, (internal) adjustable 25 to 300 PSI set point. Factory set to 100 PSI.

6.5 Pneumo Front Panel, Model 8225-HP

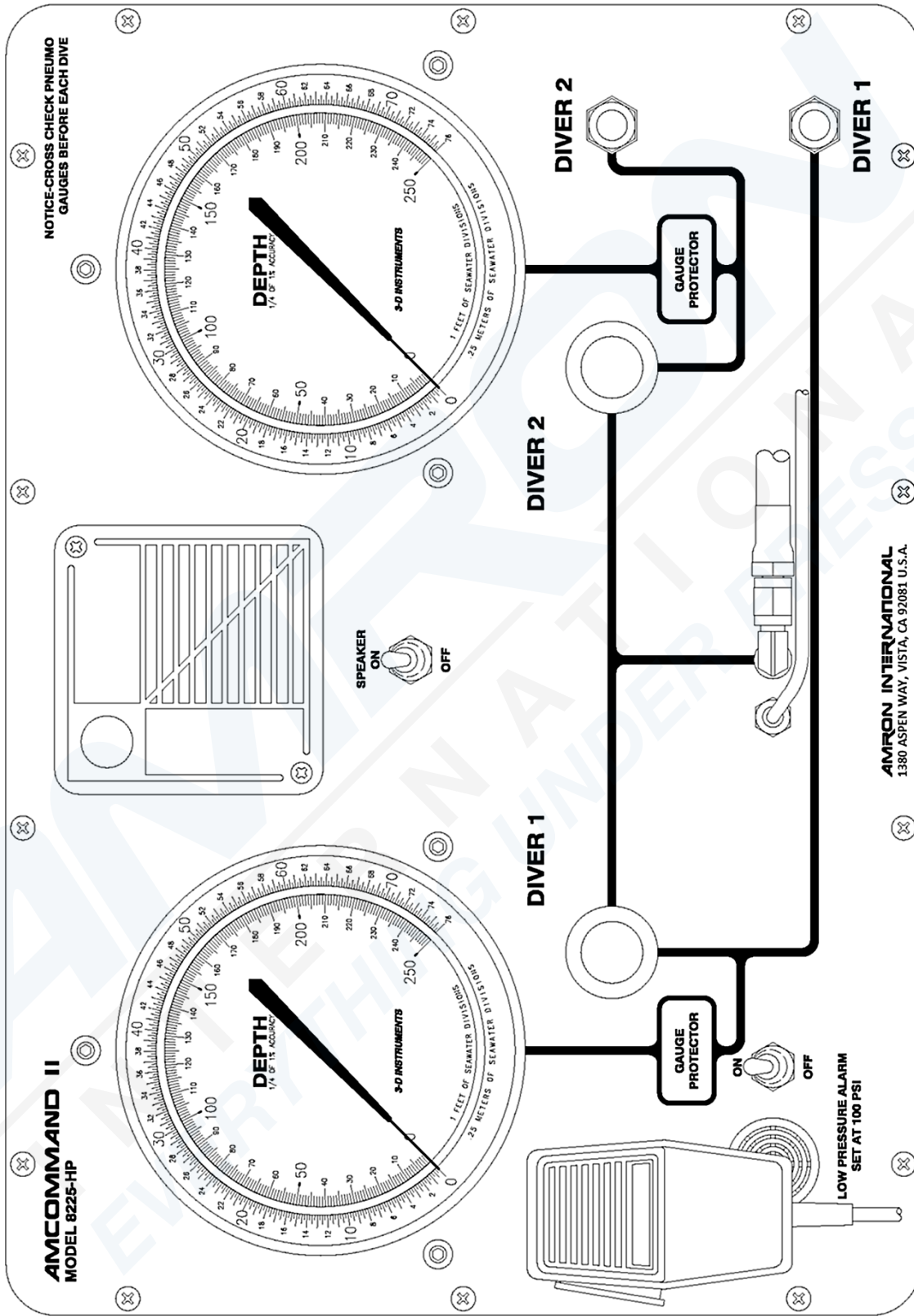

6.6 Communications

Two-way communications with diver's. high power, folded acoustic horn, provides ample volume for noisy environments. Speaker is mounted in the optimum plane to direct sound to the operator.

6.6.1 Tender Controls

POWER SWITCH – This switch controls power to the unit.

PUSH-TO-TALK ALL DIVERS BUTTON – This button allows the tender to talk to all the divers when operating in the 2-Wire mode. It is not necessary to use this control in the Full Duplex (4-Wire) mode. When using Full Duplex mode, this control allows the tender to interrupt the divers by forcing them into listen only mode.

EARPHONE VOLUME – This control sets the volume for the tender's earphone and/or **PANEL SPEAKER**. Rotate this knob clockwise to increase the volume from all the divers.

MICROPHONE VOLUME (Model 2825A only) – This control sets the level for the tender's microphone. Rotate this knob clockwise to increase the tender's volume to all the divers.

HAND HELD MICROPHONE - Convenient method to talk to divers; automatically activates the push-to-talk function and disconnects the talk back speaker reducing background noise. This feature significantly improves intelligibility.

6.6.2 Tender Connections

TAPE RECORDER – This is a single RCA Phono jack (color-coded black) that provides a transformer isolated of both the diver and tender communications. It is designed to drive the standard line-level inputs of audio or video recorders with input impedances as low as 600 Ohms.

TENDER HEADSET JACK – This is the dual banana jack (color-coded black) that functions as both an output (earphone) and input (microphone) for the tender as controlled by the **PUSH-TO-TALK BUTTON** and **PUSH-TO-TALK JACK**. Using this connection, the tender can be wired in either 2-Wire or Full Duplex (4-Wire) mode regardless of the mode used for the diver.

To connect the tender in the Full Duplex (4-Wire) mode, connect the earphone (black) banana plug of the headset to this jack and the microphone (red) to the **TENDER MICROPHONE** jack (red) as shown in the wiring diagram in section 4.9. In this mode, the tender does not have to use the **PUSH-TO-TALK BUTTON** to communicate with a diver who is also connected in the Full Duplex (4-Wire) mode. This configuration can be used even if the diver is connected in 2-Wire mode. In that situation, the tender is required to use the **PUSH-TO-TALK BUTTON** or **PUSH-TO-TALK JACK**.

The headset microphone is always active, which means that there can be acoustic feedback between the **PANEL SPEAKER** and the microphone if the tender is near the communicator. To prevent this, the **PANEL SPEAKER** can be turned off using the **SPEAKER SWITCH**. Another option is to move the tender away from the communicator by using the Amron Model 2822-28 Walk-and-Talk Module accessory. This allows the tender to communicate while

other members of the surface crew listen using the PANEL SPEAKER. This module comes with 25 feet (7.6 meters) of cable (custom cable lengths are available).

The tender can also be connected in 2-Wire mode by stacking both the earphone (black) and microphone (red) banana plugs into this jack as shown in the wiring diagram in section 4.8. The diver does not have to be connected in 2-Wire mode if the tender is in 2-Wire mode. In order to talk to the diver, the tender must use either the PUSH-TO-TALK BUTTON or PUSH-TO-TALK JACK. Since the headset microphone is not active until one of the push-to-talk methods is used, there is no chance for acoustic feedback to occur and surface conversation or noise is not transmitted to diver and the PANEL SPEAKER can be left on. This may, for some situations, make for a better overall diving experience. If the tender requires more mobility at the dive site, the Amron Model 2821-28 Remote Push-to-Talk Module can be used to extend the headset cable. It includes a push-to-talk button on a clip-on belt module and comes standard with 25 feet (7.6 meters) of cable (custom cable lengths are available).

The tender may also use the optional Amron Model 2405-28 Push-to-Talk Microphone. This microphone comes with two color-coded banana plugs. The black plug goes into the TENDER HEADSET jack and the yellow plug goes in the PUSH-TO-TALK JACK as shown in the wiring diagram in section 4.10. To communicate with the diver, the tender presses the button on the side of the microphone. There is no chance of acoustic feedback since the PANEL SPEAKER is cut off when the tender uses the microphone. When using the Push-to-Talk Microphone, the SPEAKER SWITCH must be turned on in order to hear the diver.

TENDER MICROPHONE JACK – This is a dual banana jack (color-coded red) that functions as the microphone input from the tender's headset. It is only used if the tender is in Full Duplex (4-Wire) mode. On the 2825A, the TENDER MICROPHONE VOLUME control adjusts the sensitivity of the input.

PUSH-TO-TALK JACK – This is a dual banana jack (color-coded yellow) that allows for remote keying of the push-to-talk function of the communicator. It is use by the Push-To-Talk Microphone (Amron Model 2405-28) and the Remote Walk-And-Talk Module (Amron Model 2822-28).

The difference between using the PUSH-TO-TALK JACK and PUSH-TO-TALK SWITCH is that the switch allows the tender to communicate using the PANEL MICROPHONE. If both are used at the same time, the PANEL MICROPHONE is active. This allows another crew member to talk to the diver using the PANEL MICROPHONE even if the tender is away from the communicator using the Remote Push-to-Talk Module in 2-Wire mode.

6.6.3 Diver Controls (separate controls for each diver)

DIVER EARPHONE VOLUME has separate earphone volume controls for each diver. This allows the tender to set the best individual volume for each diver.

DIVER MICROPHONE has separate microphone volume controls for each diver. This sets amplification level of each diver's microphone signal controlling that diver's volume to both the tender and the other diver.

PUSH-TO-TALK-DIVER – There is a separate PUSH-TO-TALK button for each diver. Normally used in 2-Wire mode, this control allows the tender to talk to only one of the divers.

The diver selected will hear both the tender and the other diver allowing crosstalk between the divers controlled by the tender. It can be used in Full Duplex (4-Wire) to cut off the microphone of an individual diver.

6.6.4 Diver Connections

DIVER MICROPHONE – This is a dual 5-way binding post jack (color-coded red) that functions as both an output (earphone) and input (microphone) for the diver as controlled by the PUSH-TO-TALK BUTTON and PUSH-TO-TALK JACK. Using this connection, the diver can be wired in either 2-Wire or Full Duplex (4-Wire) mode regardless of the mode used for the diver.

To connect the diver in 2-Wire mode, connect both the diver microphone and earphone to this jack. If the diver umbilical uses banana plugs, simply stack both plugs into this jack as shown in the wiring diagram in section 4.8. In this mode, the diver microphone will be active and heard on tender headset and/or PANEL SPEAKER unless the PUSH-TO-TALK BUTTON or PUSH-TO-TALK JACK is used. When a pre-amp microphone is used in the 2-Wire mode setup, it is required to have special speakers supplied only by Amron. Contact Amron for more information.

To connect the diver in Full Duplex (4-Wire) mode, connect the diver microphone to this jack and the diver earphone the DIVER EARPHONE jack as shown in the wiring diagram in section 4.9. The diver can use this mode even if the tender is wired in 2-Wire mode.

DIVER EARPHONE – This is a dual 5-way binding post jack (color-coded black) that functions as the output for the diver's earphone. It is only used when the diver is in Full Duplex (4-Wire) mode.

6.6.5 Power Connections

EXTERNAL BATTERY JACK – The communicator can be powered using an external battery or power supply via the two color coded TIP jacks. The red TIP jack is the positive power input and the black is the negative power input. The input voltage must be between 9 and 18 V_{DC} and must be able to supply a peak current of 3 Amps for proper operation. The following warnings need to be heeded when using the EXTERNAL BATTERY JACK. A minimum wire size of 18 AWG and maximum wire run of 3 feet (1 meter) is recommended.

It is strongly recommended that an Amron External Charger Model 2823-603 be used as the external power supply. The Amron External Charger was specifically designed for use with all Amron communicators and has a high degree of insulation between the primary and secondary circuits for diver protection and safety.

WARNING: The EXTERNAL BATTERY JACKS are to be used to recharge the sealed lead acid battery. It is strongly advised to use the provided Amron External Charger, Model 2823-603, to charge or operate the communicator. This charger has been designed with the necessary electrical isolation to prevent dangerous currents from the AC lines from reaching the diver.

If you use an external power supply, the maximum voltage needs to be limited to 15 Volts if the rechargeable battery is in the unit. If a higher voltage is to be used, it is advised that the battery be disconnected or removed from the communicator to prevent possible damage to the battery.

BATTERY CONDITION INDICATOR – A steady GREEN light indicates battery charge level is good. Blinking GREEN light indicates battery charge level is at a low level with less than 3 hours of running time available. Steady RED light indicates battery charge level is below the level necessary to guarantee proper operation.

6.7 Communicator Front Panel, Model 2825A-8225

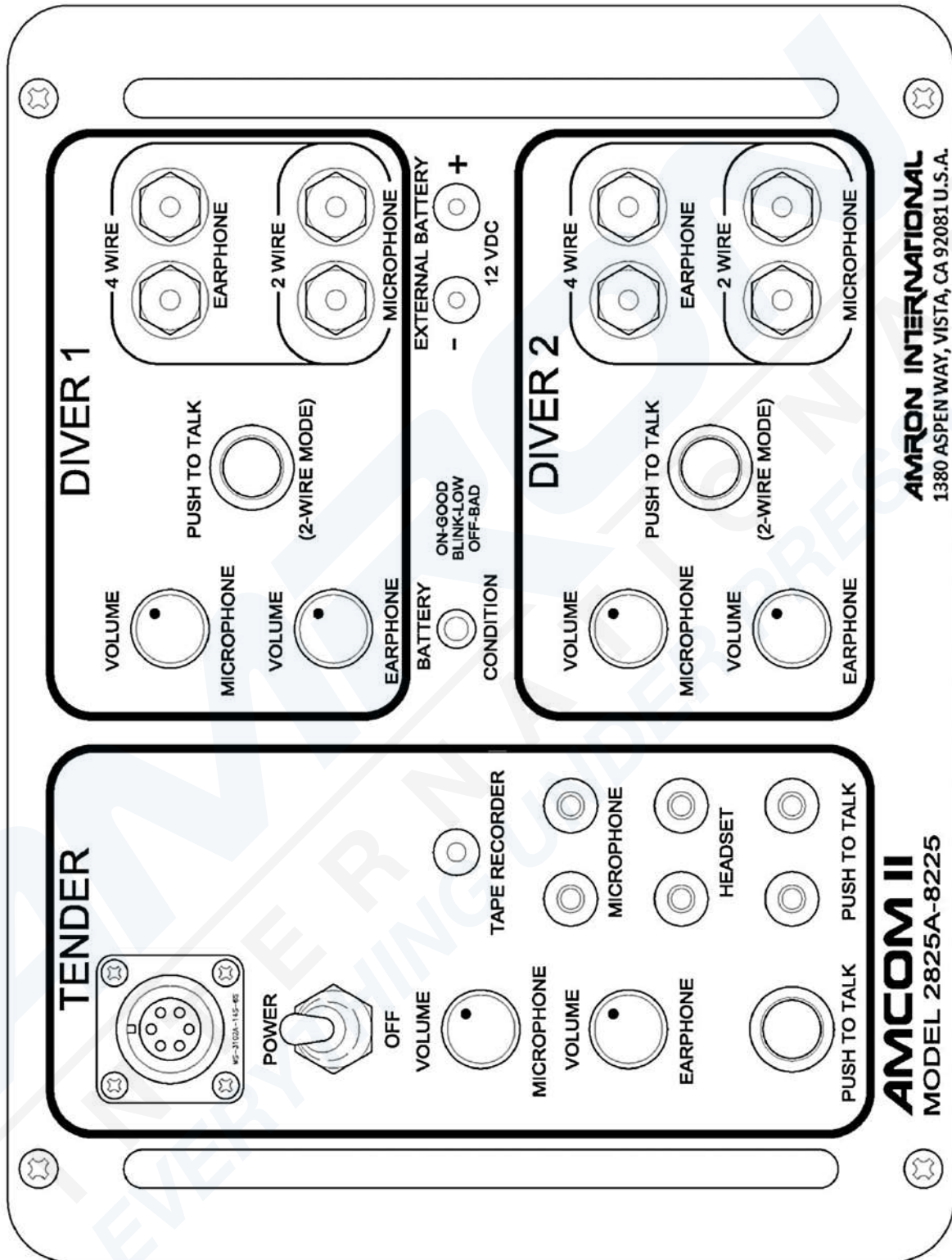

7. PRE-DIVE PROCEDURES

7.1 Pre-Dive Set-Up

1. Place AMCOMMAND II on flat surface that can support the unit. Select a working area which is secure, stable, convenient, and suitable for use during the period of the dive.
2. Open unit and remove both yokes and color coded high pressure hose whips from the storage position. Conduct a visual inspection of unit to insure no damage has occurred during transportation to the job site, or since the last time the unit was used.
3. Attach each yoke to a scuba cylinder by screwing down until finger tight. **Note:** be sure the bleeder valve on each yoke is in the closed position. (**Note:** do not turn the cylinder's air on at this time).
4. If available, a low pressure compressor should be used as the primary air supply and scuba cylinders used as a back-up air source.

Note: Low pressure compressors used for breathing air should be specifically designed for diving.

5. All hose whips should be clear of debris and have their open ends taped, capped or plugged when not in use.
6. Flush out low pressure hose whip before connecting to the AMCOMMAND II to prevent debris from entering system.
7. Attach hose whip to LP supply inlet fitting. **Note:** When tightening, USE TWO WRENCHES place one wrench on inlet fitting and hold, turn hose fitting with a second wrench making sure not to over tighten.

7.2 Pre-Dive Check Out

1. Be sure both the high pressure valves, pneumo valve, and air supply valves are in the 'off' (closed) position.
2. Regulator should be set to a low pressure, turn knob counter clockwise until the knob stops.
3. Turn the Diver output valves and pneumo valves to 'off' position.
4. With the yoke bleeder valve in closed position, turn on high pressure air at both SCUBA or breathing air cylinders. **Note:** Always open high pressure valves slowly, allow system to fill slowly before opening valves for maximum flow. Check the pressure level of both HP supplies.
5. Turn on 1 HP supply valve by turning counter clockwise four (4) full turns. **Note:** 2 HP supply valve should be in the off position and used as a back-up.

Caution: If both HP valves are opened at the same time, both air supplies will be used simultaneously. This will result in both bottles being empty at the same time. The purpose of the two supplies is to alternate between the two bottles. Use one of the bottles until it reaches 500 PSI, and then switch to the second bottle. With a full bottle on line, you can then replace the first bottle with a full unit.

6. Note the cylinders air pressure by reading the HP supply gauges.

7. Adjust regulator to desired setting by turning knob while monitoring the diver air supply gauge. Clockwise increases the set pressure.

Note: regulator setting is determined by: required over-bottom pressure for manufacturer's helmet or mask plus the bottom pressure relating to the diver's depth. See section 10-3 for gauge pressure verses depth chart

7.3 Pre-Dive Pneumo Test

The AMCOMMAND II Pneumo section has gauge protectors to protect the pneumo gauges from over pressurization. However it is good operating practice to use a procedure which will not damage the gauges when operating a system without gauge protectors. Using a standard procedure will permit the operator to use a different system without gauge protectors and operate the system correctly.

A Pneumo gauge with a range of 250 FSW/76 MSW has an equivalent full-scale pressure rating of 111.25 PSI. If you exceed this pressure by a significant amount you will cause a permanent change in the calibration of the gauge. If you exceed 111 PSI by 100% you will destroy the gauge.

Procedure for checking the pneumo gauges:

1. Pressurize the LP section of the Amcommand II; reduce the output pressure of the regulator to a pressure less than 100 PSI.
2. Open the diver output valve momentarily to reduce the pressure and check the action of the regulator. Check to see that the output of the regulator stays at less than 100 PSI.
3. Open Pneumo valve slowly, while watching the depth gauge, check that the gauge needle is slowly rising and that air is exhausting through the diver's pneumo connection (or diver's pneumo hose if connected).
4. Close valve; check depth gauge to see that it reads zero. The gauge should be within +/- 10 feet of zero. Zero will be affected by changes in atmospheric pressure and/or changes in altitude. If zero is off by more than 10 feet and there has not been a significant change in either atmospheric pressure or altitude, suspect that the gauge has been subjected to over-pressurization and may have suffered damage. Cross-check the gauge or have the gauge calibrated before using.
5. Seal the output of the pneumo section. This can be done by capping off the Pneumo output, or preferable sealing the end of the pneumo hose. Pressurize the Pneumo to 200 FSW and close the blow-down valve. This reading should hold, with out a decrease in reading. If the reading decreases you have a leak in the system, correct before proceeding.
6. Cross-checking the pneumo gauges. Either connect the pneumo outputs together, or connect the pneumo hoses together and pressurize the system, both gauges should read the same. If the gauges differ by more than 2%, have the defective gauge calibrated. Gauge calibration should be compared at several points over the range

of the gauge, with both increasing and decreasing pressure. As a minimum check the gauges over the range which the gauge will be used.

7.4 Pre-Dive Testing Communications

1. Always test the communications between the AMCOMMAND II and divers before each dive. Connect the diver's umbilical to the diver communicator, and the helmet / hat to the umbilical.
2. Turn power to "ON" position.
3. Set "Tenders Volume" at mid scale. While diver is speaking, adjust to a comfortable level.
4. Set "Divers Volume" at mid scale. Talk to diver and adjust until diver can hear tender at a comfortable level. If you are using a 2-wire system you must use the "Push-to-talk" switch, or the push-to-talk "Hand held Microphone".
5. Become familiar with the "Push- to -Talk" switch by pushing the switch when talking to the diver. **Note:** If switch is depressed, tender can not hear diver. Diver cannot hear tender if tender does not actuate the "Push- to -Talk" switch.
6. Check Diver 2 or the standby diver communication.

7.5 Connecting Diver Umbilical

1. Remove protective caps and attach diver air supply and diver pneumo hose fittings to corresponding outlets. **Note:** When tightening, place one wrench on outlet fitting and one wrench on hose fitting. Tighten hose fitting, making sure not to over tighten.
2. Blow out diver's air supply hose to insure no debris is in the line before connecting to a helmet or mask.

Connect the communication cable (surface end) to the two binding posts located on the right side of radio. Wires should be well fastened to the binding posts and not touching each other (bare wire). We strongly recommend the use of dual banana plugs attached to the top side end of the umbilical. This ensures a good connection and reduces the possibility of shorts and/or intermittent connections. Attach diver's end to helmet or mask.

Test the operation of the system.

7.6 Low Pressure Supply

Test LP supply with low pressure compressor.

Note: Adjust diver air supply pressure at compressor. The AMCOMMAND's LP supply system by-passes the regulator, therefore, cannot control air pressure entering system, or the pressure to the diver.



8. OPERATING PROCEDURES

8.1 Low Pressure Breathing Air (Primary Supply)

Low Pressure Compressor (Primary supply), High Pressure (Backup). In this mode of operation the divers breathing air is being supplied by an LP compressor, the HP Supply is use as a back-up supply. Having the HP supply as a backup does not eliminate the requirement for a bailout source of air.

In the event the LP air source fails, it is a simple matter to switch over to HP Air. Turn "ON" the HP source by opening the HP-1 valve. Check the diver's air supply pressure.

8.2 High Pressure Breathing Air (Primary Supply)

In this mode of operation the divers breathing air is being supplied by via high pressure breathing air source. This could include SCUBA tanks (singles or twins), high pressure storage cylinders, or a bank of high-pressure storage cylinders.

Caution!

Maximum input pressure limit of 3000 PSI when using standard CGA850 yokes.

Maximum input pressure limit of 4500 PSI when using optional 300 Bar DIN adapters.

The High Pressure breathing system is designed to allow the rotation of bottles as they are consumed. Operate the system using a single bottle until the bottle pressure has dropped to approximately 500 PSI, then switch to the next bottle. Repeat this procedure alternating between HP-1 and HP-2, changing bottles as they are used. The HP input system has check valves, which prevent back-flow between the bottles. This facilitates switching between bottles.

Example:

If you have two bottles connected to the system and you are using bottle HP-1, bottle HP-2 is "OFF", when HP-1 reaches 500 PSI, you may switch to HP-2 by opening the valve for HP-2. The system will draw air from the higher of the two sources, HP-2. You can then turn HP-1 "OFF", and change the bottle connected to source HP-1. This procedure ensures an uninterrupted supply of air to the diver.

After turning HP-1 off, turn the bottle valve off, open bleed-valve on the yoke and bleed the pressure. Release the yoke and replace the empty bottle with a full bottle. Close the bleed-valve and turn SCUBA cylinder on and verify the bottle is full.

Another method of changing bottles is to leave both valves on the system in the "ON" position. Use the SCUBA bottle valves as the ON/OFF control for selecting which

bottle is in use. This reduces the number of valves, which must be open and closed for each change of bottles. If you use this procedure, you should monetarily open the new bottle and check the gauge to ensure the bottle is full, then close bottle to prevent the system from using air from both bottles at the same time.

1. When planning your dive you must take into consideration the amount of time a given bottle will last and the number of bottle changes, which will be necessary during the dive. There are two options that can be used to accommodate dives that will have a high consumption of air.
2. Use twin tanks instead of singles. Use a high volume cylinder (250 - 300 cubic feet) of breathing air; these can generally be rented from a welding gas supplier, or supplier of industrial gases. Make sure you specify breathing air, and request certification. These cylinders can be also be manifolded quite easily. Generally the charge for rental is very competitive in cost and usually includes delivery to the job site.

Note: When using high-pressure cylinders, care must be exercised in the handling, transport and storage of it. Make sure all personnel involved are instructed in the proper procedures. If you have any questions regarding the proper procedures contact your supplier.

8.3 Pre-Operation Checklist

1. Diver dressed and ready except helmet / hat
2. Diver's umbilical organized
3. LP Compressor running and at pressure
4. LP Alarm in "ON" position
5. HP source connected and ready, HP-1 and HP-2 valves "OFF"
6. Zero Pneumo Gauges
7. Diver air ON, purge diver Helmet / hat
8. Diver dons helmet / hat
9. Diver communicator ON, Comm check
10. Diver air check
11. Diver enters water
12. Record the starting time of the dive

During the dive, the tender shall maintain voice communication with the diver at all times. Tender shall monitor diver's air pressure and breathing rate

8.4 Pneumo Readings

During the dive, the tender shall monitor the diver's depth, recording the depth and time at depth. The procedure for measuring depth is as follows.

1. Advise the diver that a pneumo reading is to be taken.

2. The diver will place the end of the pneumo hose at the point at which the measurement shall be taken. Diver will advise the tender he is ready for the pneumo reading.
3. Slowly open the Pneumo valve corresponding to the diver whose depth is being measured. The Pneumo gauge reading will increase and stabilize at a value greater than the depth of the diver. The value will depend upon the flow rate, and pressure drop over the length of the pneumo hose. The diver will advise the tender of bubbles coming from the end of the hose.
4. Close the pneumo valve, the reading will to decrease to the value of the diver's depth. Once the reading has stabilized, this is the depth at the end of the pneumo hose.

Note: Pneumo readings can be used for several purposes i.e., measuring the diver's depth, depth to a particular point under water, vertical distance from one underwater object to another. The accuracy of the measurement is plus or minus 0.625 feet of seawater, (+/- 7.5 inches). This represents an overall accuracy of +/- 1/4 of 1% of the full-scale value of the depth gauge. To maintain this accuracy the gauges must be calibrated every 6 months.

When using the pneumo system to measure the diver's depth for use in determining decompression requirements, please note the following:

8.4.1 Definitions of terms, PAR 7.1

DEPTH - When used to indicate the depth of a dive, it means the maximum depth attained by any part of the diver during the dive, measured in feet of seawater.

8.4.2 Selection of decompression Schedule, PAR 7.2.3

- (A) Always select the schedule depth to be equal to or the next depth greater than the actual depth to which the dive was conducted, and
- (B) Always select the schedule bottom time to be equal to or the next longer bottom time than the actual bottom time of the dive.

8.4.3 Rules during ascent, PAR 7.4.1

Decompression Stop Depth - The diver's chest should be located as close as possible to the stop depth.

The above information is quoted from the U.S. NAVY DIVING MANUAL, Chapter 7, Air Decompression.

8.5 Diver Communications

The AMCOM SERIES II can be operated in two basic modes of operation. The conventional method of operation is known as 2-wire, this allows the diver to be heard by the tender, but requires the operator/tender to actuate the Push-To-Talk switch in order to talk to the diver. The modern method of operation allows two way conversations to be carried on simultaneously. Amron calls this method of operation "FULL DUPLEX". The diver and tender can talk to each other as you would on a telephone. The same applies to diver to diver conversations. Amron tries to encourage the use of FULL DUPLEX for superior communications and safety.

The Model 2825A-8225 has the capability of 2-wire and/or FULL DUPLEX (4-wire) communication modes. FULL DUPLEX and 2-wire can be used simultaneously (mixed), divers on FULL DUPLEX, tender on 2-wire.

2-wire communication is defined as a single communication path. The diver is the priority signal path, tender listens to diver. Signal reversing is accomplished by pushing the Push-To-Talk switch; diver hears tender. Often times a 4-conductor (4 wires) common cable is used with two wires tied together as a pair (this is done for redundancy.), however this is still a 2-wire system.

FULL DUPLEX communication is defined as a dual communication path; a signal path (a pair of wires) for up-link and a signal path (a pair of wires) for down link. A common example of FULL DUPLEX like communication is the telephone. This permits the freedom of natural communication, lower system noise, and diver to diver communication without having to attempt Crosstalk switching.

For an in depth discussion on FULL DUPLEX refer to FULL DUPLEX, WHAT, WHY, AND HOW!, located at the end of the operation section of this manual.

8.6 2-Wire Operation (Refer to Figure 3)

1. Connect the comm cable from the divers to Diver 1 and/or Diver 2, Microphone (inputs) under the words "2-wire". Wires should be well fastened to the binding posts and not touching each other. A good method of attachment is to use a dual banana plug (AMRON P/N 14001B). If more than one diver is connected to any microphone (input), (Diver 1 or Diver 2), those divers on the same two terminals will not be able to crosstalk.

The earphone connection is not used by the divers. The earphone jacks can be used to operate a remote speaker; both diver and tender conversations will be heard.

2. In 2-wire, the tender must press the Push-To-Talk switch to be heard. If you are using the (optional) AMRON Remote Walk and Talk, Model 2821-28, the tender may press the Push-To-Talk switch on the belt module.

8.6.1 Volume Controls - Set all volume controls to mid scale.

- (A) **Tender**
 - (i) Divers to Tender – Adjust to comfortable level
 - (ii) Tender to Divers – Adjust to comfortable level
- (B) **Diver 1**
 - (i) Divers to Tender – Adjust to comfortable level
 - (ii) Tender to Divers – Adjust to comfortable level
- (C) **Diver 2**
 - (i) Divers to Tender – Adjust to comfortable level
 - (ii) Tender to Divers – Adjust to comfortable level

8.7 Diagram, 2-Wire Set-Up Instructions (Figure 3)

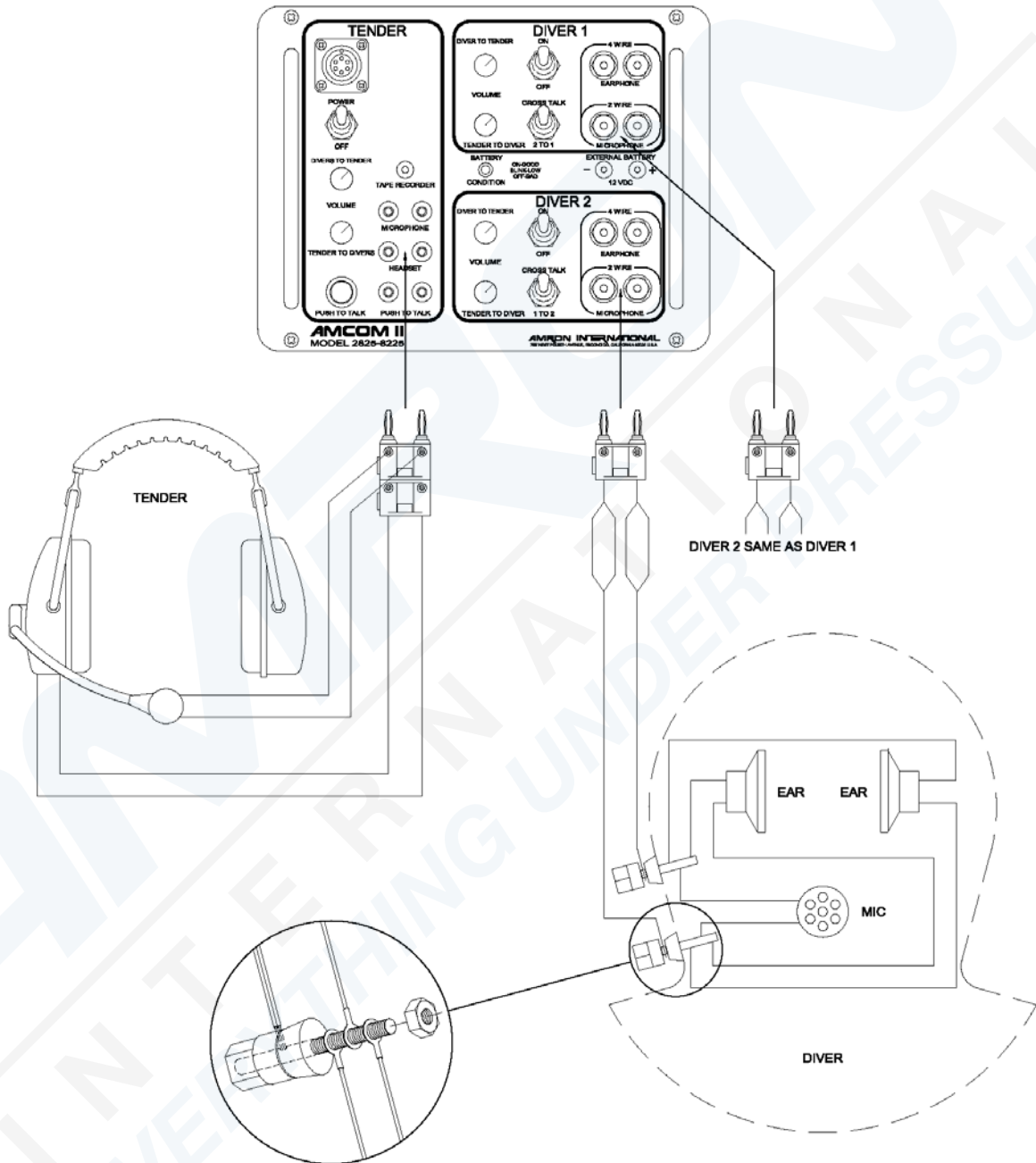

8.8 FULL DUPLEX (4-Wire) Operation (Refer to Figure 4)

- A. Connect the two wires from the diver's microphone to the 'Microphone (Input) Diver'
- B. Connect the two wires from diver's earphones to the 'Earphone (Inputs) Diver 1'.
- C. Repeat the same for Diver 2.
- D. Connect tender headset earphones (black dual banana plug) to headset (input).
- E. Connect headset microphone (red dual banana plug) to tender microphone.
- F. Turn speaker off to avoid acoustic feedback.
- G. Operation with speaker is possible by extending tender's headset away from the speaker. Use AMRON Model 2822-28 headset extension cable (25 foot).

Note: When operating with a standby diver who does not have his helmet / hat on, acoustic feedback (squeal) may occur. This can be avoided by turning his volume down (Diver to Tender), which cuts off his microphone, yet will enable him to monitor the diver/tender conversation through his helmet / hat earphones. Or you can disconnect (UN-plug) his microphone circuit that will disable his microphone.

8.8.1 Volume Controls

Set all volume controls at mid-scale. Tender should don headset and talk to himself. If adjustments are required, increase or decrease volume (controls). This will establish a system volume level.

8.8.2 Tender Volume Controls

- A. Divers To Tender - Use as a master control.
- B. Tender to Divers - Use as a master control.

If conditions change as a group, the tender volume controls can be used as master volume control.

8.9 Diagram, FULL DUPLEX 4-Wire connection Model 2825-8225 (Figure 4)

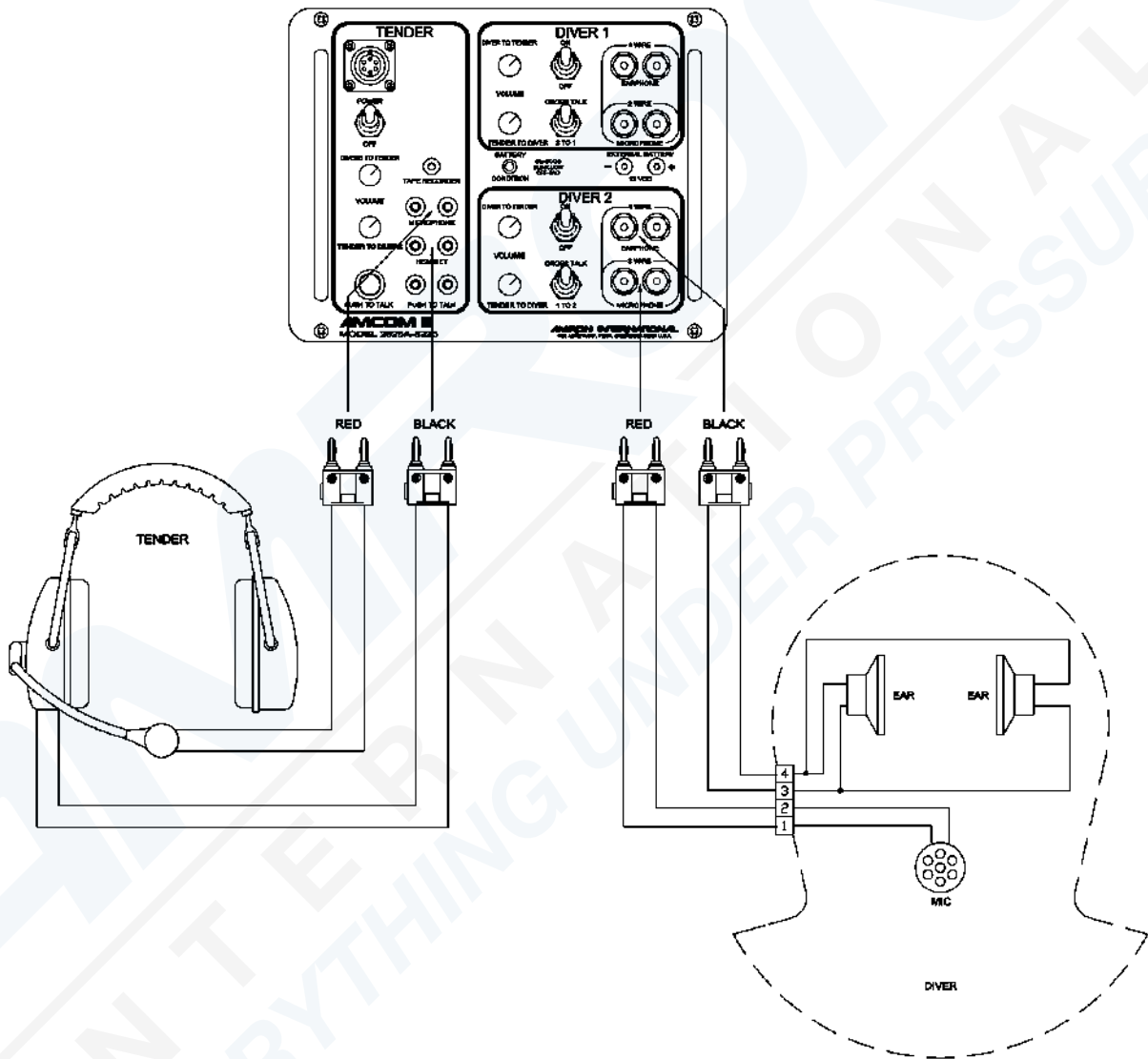

8.10 FULL DUPLEX (4-WIRE) – WHAT, WHY AND HOW

Amron has designed the AMCOM Full Duplex (4-WIRE) mode from the ground up, taking advantage of state-of-the-art electronics technology to provide a superior hard-wire communication experience. Full Duplex (4-Wire) mode has the following advantages:

- Up to 285% more signal strength from the diver microphone over the 2-Wire mode using standard 8-Ohm microphones.
- No push-to-talk required leaving the tender's hands free for other tasks.
- The diver and tender can hear themselves talk providing a more natural communication experience.

These advantages produce superior communications and the system is easier to operate by eliminating the need for using a push-to-talk switch. Another advantage is that the system is easy to troubleshoot. In fact it is easier to troubleshoot than 2-Wire system once you understand what is happening. Full Duplex (4-Wire) mode pays off in better communications, something that many of our competitors have yet to achieve. Better communications means higher diver production, safer dive conditions and less down time.

8.10 WHAT ARE 2-WIRE AND 4-WIRE MODES?

8.10.1 2-WIRE MODE

2-Wire mode is the most commonly used communication mode in the commercial diving industry. Technically it is defined as a single communication path using a minimum of 2 wires in a communication cable. Being a single path, there can only be one talker at a time. Commonly the diver has the priority and the tender listens as the diver talks. In order for the tender to talk to the diver, this communication path has to be reversed. This is done by the tender pressing a push-to-talk switch. This switch activates a set of relays that switch the diver connection to the output side of an audio power amplifier and the tender connection to the input side. This allows the tender to talk while the diver listens.

Most diver communication cables, such as the "Army surplus Comm-Cable," have four wires. These four wires are often separated into two sets of twisted-wire pairs. In many diving operations, these two sets of twisted-pairs are connected in parallel for redundancy. A breakage in a single wire in the cable does not cause a loss of communication, as each wire has a parallel wire to take over. This arrangement is still a 2-Wire mode even though 4 wires are being used.

8.10.2 4-WIRE MODE

4-Wire mode uses two communication paths: an uplink from the diver to the tender and a downlink from the tender to the diver. This allows voice communications to go in both directions at the same time. An example of this type of communication system is the telephone. Another example is called Round Robin communications. Amron's Full Duplex (4-Wire) is not the same as Round Robin.

8.11 WHAT IS FULL DUPLEX (4-WIRE)?

It is a 4-Wire dual communication path system that uses special audio amplifiers on the microphone and earphone connection to eliminate the issues associated with Round Robin systems. It allows everyone on the communicator to talk to each other just as if they were on a telephone.

8.11.1 WHY ARE SPECIAL AMPLIFIERS NEEDED?

When developing a 4-Wire communication system, the biggest problem facing the designer is oscillation caused by feedback. This can occur in two ways. The most common is acoustic feedback, also called the Larsen effect, which occurs when the microphone picks up the sound from the speaker and feeds it back into the amplifier. This signal is amplified and sent out the speaker at a higher level. Given the right conditions, this process repeats until the amplifier reaches maximum signal level. The result is usually a high pitch, howling sound commonly heard in public address systems when the volume is turned up too high.

The solution for acoustic feedback is to turn down the amplifier volume and to isolate the speaker from the microphone. In a dive helmet, the diver's head makes a good acoustic isolator. On the surface, a tender using a headset may get some acoustic feedback via the PANEL SPEAKER. The solution is to put some distance between the tender and the PANEL SPEAKER by using the Amron Model 2822-28 Walk-and-Talk Module accessory. Alternatively, the PANEL SPEAKER can be turned off using the SPEAKER SWITCH located on the front panel.

There exists a second, more difficult to avoid feedback path that can also cause oscillation. In 4-Wire mode, there are two sets of wire pairs. One pair carries the signal from the diver microphone to the communicator microphone input. This is an extremely low level signal, typically in the range of about 1mVRMS. The second carries the output signal from the communicator power amplifier to the diver's earphone. This signal can be as high as 4VRMS. The earphone signal is typically about 1000 times greater than the microphone signal and can be as much as 4000 times greater. If the signal on the earphone wire pair were to couple to the microphone wire pair, the result would be a feedback path that can lead to oscillation. To prevent such coupling, the dive cables are constructed using two individual twisted wire pairs and in high quality cables, such as Amron's CC1 communication cable, each pair can be shielded to provide additional protection. Shielding does decrease the amount of coupling between the wire pairs but without special amplifiers, the full capability of using twisted wire pairs is lost.

Amron Diver Communicators are designed with a special balanced circuit, differential input and output amplifiers. In a balanced circuit, each wire in the twisted pair carries an equal and opposite signal. Each wire generates an electromagnetic field that is in opposition with the field of other wire. The net result is that strength of the radiated electromagnetic field is significantly reduced if not totally eliminated. In addition, any external fields, either from the other wire pair or an external noise source, will be coupled to both wires equally creating a common-mode signal. The differential microphone amplifier in Amron Diver Communicators

cancels the common-mode signal while amplifying the signal from the microphone. Communicators without both differential input and output amplifiers cannot match the performance of Amron Diving Communicators. This is an extreme simplification of the common-mode coupling effect and common-mode signal rejection but shows the power of Amron's Full Duplex (4-Wire) mode of operation.

8.11.2 ISN'T ROUND ROBIN THE SAME THING?

In Round Robin communication systems, each diver is connected using a 4-Wire cable like the Amron Full Duplex (4-Wire) mode. This is where the similarities end. In Round Robin systems all the microphones are connected together in parallel and connected to the microphone input of the communicator. All the earphones are also connected in parallel and connected to the earphone output of the communicator. Each microphone is loaded by all the other microphones in the system causing lower output. In a two diver setup where the diver microphones have a typical impedance of 8 Ohms and the tender's microphone has an impedance of 150 Ohm, the diver microphone output level will be reduced by about 50% while the tender's microphone is attenuated by out 95%. On the earphone side, the diver earphones commonly have an impedance of 8 Ohms while the typical tender earphone impedance is around 175 Ohms. These two factors combine to create a serious volume imbalance which requires higher volume settings resulting in more noise and less system stability.

8.12 WHY FULL DUPLEX (4-WIRE)?

Amron Diver Communicator uses an independent microphone amplifier for each diver circuit as well as for the tender. This allows Amron Diver Communicators to use the power of common-mode rejection to cancel any coupled noise for each microphone as well as providing less loading of the microphone than in 2-Wire mode. In 2-Wire mode, the diver microphone is wired in parallel with the diver earphones. Assuming that the impedance of the microphone is the same as the earphones, the signal from the microphone is attenuated by 65%. By separating the microphone from the earphones, the output signal from the microphone increases by 285%. With more signal, the volume level can be decreased resulting in less noise and improved system stability for a significant improvement in overall clarity.

8.13 HOW DO YOU USE FULL DUPLEX (4-WIRE)?

In order to use Amron's Full Duplex (4-Wire) mode, you need the following items:

- An AMCOM series diver communicator
- A good quality dive communication cable with four wires (two twisted wire pairs) like Amron's CC1
- A dive hat/helmet with connection for 4 wires such as a Marsh Marine connector

To connect the system together, refer to appropriate section of the operating manual for AMCOM diver communicator. In general it involves three steps (using the Amron CC1 cable):

1. Install male Marsh-Marine 4-pin connector in hat/helmet. Attach black and white wires to binding post and both speakers. Attach red and green wires to leads from microphone. It doesn't matter which color goes to which lead. Use 8-32 x 1/4 SS screw and nuts, cover each with tape or shrink tubing. You are now finished with the diving hat/helmet.
2. Install 4-pin female Marsh-Marine connector on diver's end of communication cable. Connect red and green wires to the light colored pair of communication cable wires; black and white wires to black pair of communication-cable wires. You are now finished with this step.
3. Install black dual banana plug to black pair of wires on tender end of diver communication-cable and attach red dual banana plug to lighter color pair of wires. If you don't have red dual banana plugs, red tape will serve to identify that pair as the microphone circuit. **YOU ARE FINISHED!**

To setup and check-out the communication link:

1. Attach hat/helmet to umbilical.
2. Attach communication cable to AMCOM diver communicator. Connect the red banana plug to DIVER MICROPHONE (red) jack and the black banana plug to DIVER EARPHONE (black) jack.
3. Set the volume controls to mid-range on the communicator. Turn on the communicator. There may be some acoustic feedback, if that occurs then reduce the volume until it feedback stops.
4. Don the hat/helmet and start talking. You should hear yourself in earphones. Adjust the volume as necessary for clear communications.

To revert back to 2-Wire mode, simply remove black banana plug from DIVER EARPHONE (black) jack and plug it on top of DIVER MICROPHONE (red) plug.

Things to keep in mind when using Amron's AMCOM diver communicators:

With the AMCOM diver communicators you can mix 2-Wire and Full Duplex (4-Wire) modes of operation. For example, the diver can operate on Full Duplex (4-Wire) mode while the tender operates in 2-Wire mode. The tender can use the panel speaker to listen to the diver and talk to the diver by pressing the push-to-talk button and using the panel speaker as a microphone.

When using AMCOM diver communicators with multiple diver capacity, each diver can be wired in either 2-Wire or Full Duplex (4-Wire) mode. All divers do not have to operate in the same mode.

The push-to-talk button overrides the diver conversation by forcing all divers into listen only mode. This occurs whether the diver is wired in 2-Wire or Full Duplex (4-Wire) mode.

9. THEORY OF OPERATION

This section is divided into two parts, the first deals with the mechanical and the second deals with the electronics.

Refer to the functional block diagram while reading this section.

1. HP-1 and HP-2, high-pressure input, has a maximum input pressure limit of 3000 PSI when using standard CGA850 SCUBA yokes with bleed valves and color coded hose protectors.

Installing the optional 300 Bar DIN Adapter (Amron Part No. HAS-300D) will increase the units maximum input pressure limit to 4500 PSI. Simply remove CGA850 yoke nut and yoke from bleeder body, screw on the 300 Bar DIN Adapter and tighten with a wrench.

The SCUBA yokes can also be removed for connection directly to a high-pressure bank with a maximum pressure limit of 4500 PSI. The hose fitting is 1/4 inch 37° flare, female swivel.

2. HP gauges, 0-6000 PSI, 1-1/2 % of full-scale accuracy.
3. HP valves, shut-off type, four turns opens to full flow, S/S stem with KEL-F seat for positive shut off, and Viton O-rings.
4. HP check valves, 1/3 PSI cracking pressure.
5. HP filter, inline 50-micron filter element.
6. HP regulator(s), self-contained, direct acting, spring loaded, diaphragm operated pressure-reducing regulator. Control pressures are obtained by adjusting the control knob. Pressure INCREASES are made by a clockwise rotation while pressure DECREASES are made by a counter-clockwise rotation.

Note: Regulator is a non-venting design and adjustments to decrease the set pressure will not occur unless there is flow through the regulator. If the diver is not on, line adjustment can be made by opening the pneumo valve slightly while adjusting the regulator. All final adjustments should be made in the clockwise direction in order to insure the most accurate set point.

When operating in cold weather (40° to 45° F and below), regulator icing may occur. This is caused by moisture condensing and freezing, this can and will cause blockage in the regulator. Increasing the pressure will temporarily clear the blockage by lifting the valve seat to allow the ice to blow through. If this happens terminate the dive immediately. The following information provides a guide to the causes and procedures that can reduce the possibility of icing.

The cause of icing is moisture in the breathing air combined with a cold temperature, and high flow rates. Cold air containing moisture is particularly prone to icing. First, air that is cold will support less moisture before condensing occurs. Second, the colder the air is the closer it is to the freezing point. Third, when air passes an expansion point (the regulator control valve) it is further cooled. The combination of these three factors causes the icing.

To reduce the chance of regulator icing, use the following procedures.

- 6A. Make sure the breathing air source is dry. Scuba cylinders should be filled from a compressor with a good filtration system. The air source for the filling compressor should be from outdoors, and the filling of the tanks should be done on a cold dry day.
- 6B. Place the AMCOMMAND II and the bottles in a warm location. This can be a temporary shelter with a portable heater.
7. Relief valve, factory set to 285 PSI. This valve is set to relieve the system pressure in the event the regulator should fail to control the pressure. The exhaust port for this valve is located between the diver output connections. If this valve should ever vent during a dive, the dive should be terminated immediately. Correct the cause of the problem before using the system again. You can control the outlet pressure by using the input valve (HP-1 or HP-2) as a throttle valve, closing the valve to reduce the pressure to the system. Open the valve slightly upon reaching the approximate pressure required; adjust the valve slightly to match the flow required by the diver. You can advise the diver to go to free flow, which will maintain a constant flow rate making it easier to control the pressure.
8. LP input, the input is straight forward using a check valve to eliminate the need for another panel valve and facilitate switching from LP to HP air.
9. Output gauge monitors the pressure to the diver. Gauge range is 0-600 PSI, 1-1/2% of full-scale accuracy.
10. Diver output valves, 3/8 inch ball valves, 1/4 turn full open, unrestricted flow -- one valve for each diver.
11. Low-pressure alarm monitors diver's breathing air pressure; audio alarm is factory set to come on at 100 PSI. Accuracy is +/-15 PSI. Audio alarm set point is internally set and can be adjusted to turn on anywhere between 30 and 285 PSI. Audio output is approximately 90 dB at 2900 Hz. The alarm has an ON/OFF switch to disable the alarm. The diver communicator supplies power for the audio alarm. Power is available regardless of whether the communicator is on or not.
12. Pneumo Fathometer system, the depth measurement system consists of the two depth gauges, blow down valves, output connections, and gauge protectors. The operation of the pneumo system is based upon the density of seawater that is 64.043 lb/ft³. The weight of a column of

sea water one inch, by one inch, by one foot in height is .44473 (64.043 lbs. divided by 144 sq. inches). For underwater calculations this is rounded off to three places or .445 lbs. per square inch. Therefore by measuring the pressure, we can calculate the depth. To avoid doing the calculation we use a very accurate gauge that reads the pressure in pounds per square inch, but has the dial calibrated in feet of seawater.

Note: Fresh water has a density of 62.366 lbs/ft³, therefore the same calculations equals .433 lbs. per square inch. These differences must be taken into consideration when diving in fresh water, particularly decompression stops. See Section 10 for fresh water vs. sea water tables, "Diver's Handbook of Underwater Calculations", or U.S. Navy Diving Manual for additional information regarding fresh water diving.

The pneumo system operates on the bases of a tube extending from the surface of the water to the depth at which the measurement is going to be taken. Air (pressurized) is forced into the tube, until all the water is forced out of the tube. In fact, bubbles of air will come out of the end hose. The air is then shut OFF, (this eliminates any additional pressure from flow) the pressure will then stabilize equal to the pressure at the end of the hose. The pressure in the hose will then equal the pressure at the end of the hose, and the depth.

The pressure is then read on a very accurate gauge. The dial of the gauge is calibrated in feet of seawater rather than pounds per square inch (PSI), eliminating the need to convert from PSI to FSW.

The pneumo gauges have a 6-inch dial, dual scale 0-250 FSW/0-76 MSW, with 1-foot calibration increments. The accuracy of the gauge is 0.25% of full scale. Gauges are supplied with calibration certificates traceable to the National Bureau of Standards. The gauges must be Calibrated every six months to guaranty their accuracy. Gauges should be cross checked before every dive, if there is a discrepancy of more than 2% between gauges, the gauges must be calibrated before being placed in service.

Pneumo valves, one for each diver, shut off type valve, KEL-F seat for positive shut-off.

Pneumo gauge protectors, each pneumo gauge is protected by an automatic valve which is factory set to shut off all pressure to the gauge when the pressure reaches or exceed the set point. The set point for a slow rising pressure is approximately 10% above full scale, 122 PSI. Fast rising pressures will be shut off at a lower pressure. The gauge protector will automatically release when the pressure is reduced. The gauge protector also includes a gauge snubber to protect the gauge from pulsations (shocks) in the pressure applied to the gauge.

9.1 Flow Diagram, Model 8225-HP

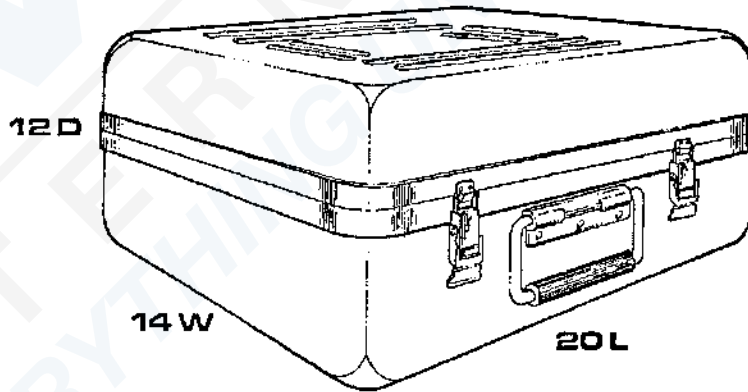
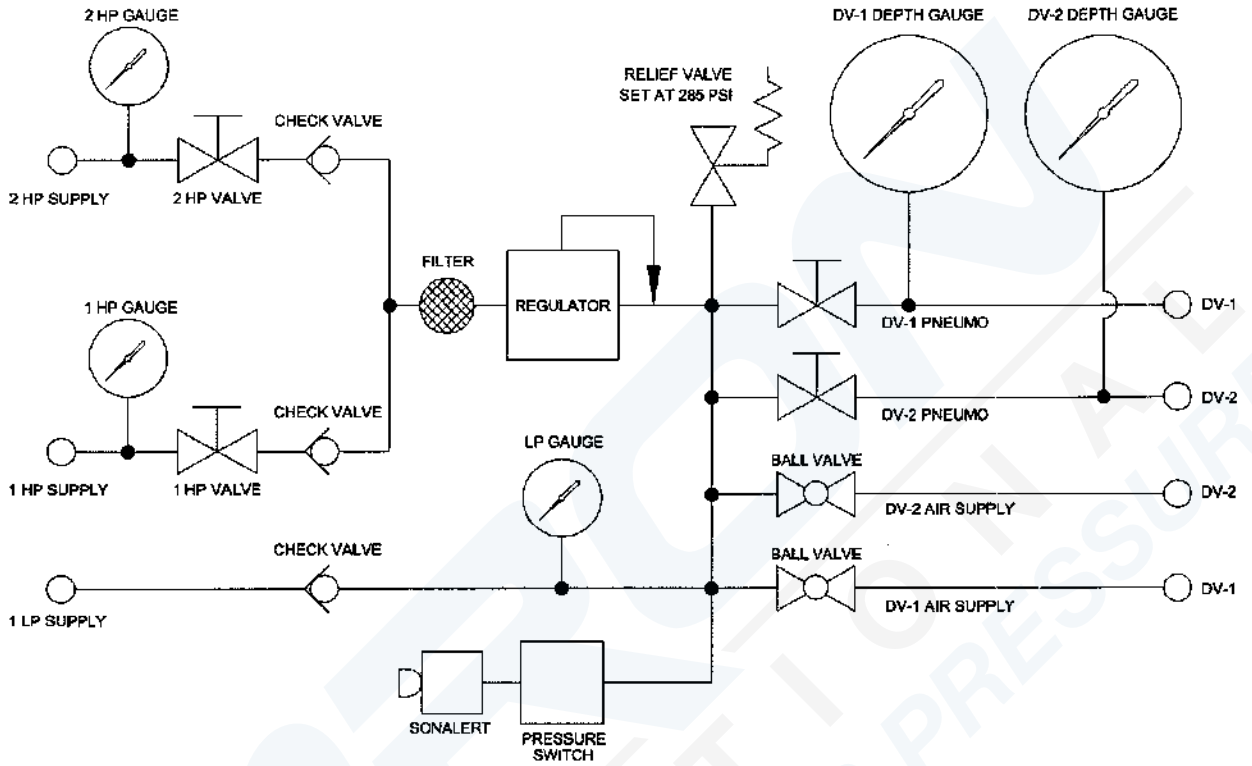

9.2 Electrical

The diver communicator is fundamentally an intercom, providing two way communication between the diver and the tender or operator. The Model 2825A-8225 can be operated in two different modes; 2-wire which requires the use of the push-to-talk switch or Full Duplex (4-wire) where voice conversations are the same as a telephone. In the Full Duplex method of operation, all persons on the system will be able to talk to each other, just as a party line phone system.

Although Full Duplex requires the use of four wires, it does not require a special grade or type of cable. Standard diver umbilical wire (Army surplus cable) will work very effectively. Once implemented, the system is very easily maintained and simple to use.

The 2825A-8225 incorporates another unique feature, the push -to -talk, hand-held microphone with automatic speaker cutout. This feature cuts out the talk back speaker when the tender is using the hand-held microphone. This eliminates the background noise found around most diving operations. Compressors, cranes and other construction equipment noise is effectively blocked out of conversation to the diver, reducing or eliminating "come back" or "say again".

Another innovation of the AMCOM series of diver communication systems is the design of the diver-input connections. The 5-way binding posts are spaced to accept dual banana plugs. We strongly recommend the use of dual banana plugs as a measure to improve reliability of the communication system. Also all connections should be soldered. Bare copper wire corrodes very quickly, however wire which has been tinned (soldered) is almost impervious to corrosion. A system properly designed and implemented will provide years of satisfactory service. The Talkback speaker has been located in the pneumo panel for two reasons. The first is space; the second is to place the speaker in an optimum position in relation to the tender.

Refer to the functional block diagram (figure 4) and schematics while reading this section.

SIGNAL INPUT - U1, U2, and U3, are differential input amplifiers that accept dynamic microphone level signals (1 to 10mv.) and amplify them. Signals common to both inputs are rejected, common mode rejection, (CMR).

VOLUME CONTROL - The input amplifier output signal is attenuated through tender volume control R103 and diver volume control R107, and R108. Each individual microphone signal can be adjusted before going to mixer U4.

MIXER - U4 is a unity gain-inverting amplifier that mixes microphone inputs from diver and tender. The output of mixer is then used to drive the pre-drivers.

PRE-DRIVER AND INVERTOR- U5 is a dual operational amplifier. The first amplifier is a unity gain inverting pre-driver and its signal goes directly to U6, one of the two audio power amplifiers. The second amplifier of U5 inverts at unity gain the signal from the first amplifier and feeds it to U7, the second power amplifier.

AUDIO POWER AMPLIFIERS - U6 and U7 are audio power amplifier integrated circuits connected in a bridge configuration. The output “floats” at approximately 6 volts and should never be connected to ground. The amplified audio “output” signal is directed to divers or tender through relays K1 and K2.

BIAS LEVEL - Resistor R39 and diode determine the bias voltage for the amplifiers U1, U2, U3, U4, and U5. It should be 4.3 Volts measured to ground +/- 10%.

AUDIO OUTPUT VOLUME CONTROLS - R104, R105 and R106 attenuate output levels to diver earphone and tender headset.

2-WIRE OPERATION - Input audio signals from divers are amplified through the circuitry described previously, and directed to the tender’s headset and speaker through relays K1 and K2. When tender actuates the push- to -talk switch, tender’s speaker and headset are connected through relay K1 to microphone input. Divers are connected to audio output through relays K1 and K2.

SWITCHES - S1 AND S2 break connections to diver microphone jacks. Crosstalk switches S3 and S4 connect appropriate diver microphones to audio output.

FULL DUPLEX (4-wire) - Tender and diver microphone are connected to amplifier inputs at all times. Tender headset and diver earphone are connected to audio output at all times.

BATTERY CHARGER - Maintains batteries at full float charge of 13.8 To 14.4 Volts. Front panel AC power “LED”, indicates when AC power is applied to unit. Charger protects batteries from overcharge by automatically switching to float charge when batteries are fully charged.

BATTERY SENSE CIRCUIT - Electronically senses voltage from battery. Controls panel "LED" (battery condition indicator) which indicates: steady light - battery is Good, blinking light - low battery, no light - below reliable operational range or no voltage. Sense points, above 11 volts +/- .25 volts = Good (steady light). 11.0 to 10.0 volts +/- .25 volts = Low (blinking light). Below 10.0 +/- .25 volts = Bad, battery is below reliable operating range. Rechargeable batteries should not be operated below their normal operating voltage, permanent damage can occur. They should not be left in a non-charged state.

We strongly recommend the batteries be put on charge and left on charge when not in use. This will solve two problems, 1) the unit will always be ready to be put in service, and 2) it ensures the batteries will be charged as soon as the unit is returned from the field. In cold weather operation, expect reduced battery performance under cold conditions; also discharged batteries are subject to freezing and damage. The capacity of the battery will be reduced by approximately 40% at temperatures of 0°F. Charging of the batteries should be done within the temperature range of 32°F to 104°F. The ideal temperature for recharging is between 50°F to 86°F.

Battery Life - Several factors affect the life of the battery. These factors are discharge rate, depth of discharge, charge rate, operating temperature, and storage temperatures. The general rule of thumb is 300 charge cycles, or 3 years. The failure of the battery is not a complete catastrophic failure at the end of its life but a general deterioration in performance over the life of the battery.

10. MAINTENANCE

10.1 Review of Scheduled Maintenance

The inherent quality of your AMCOMMAND II will provide years of continuous failure-free service if properly used and maintained.

1. Before and after each dive: do Functional test, clean and inspect for damage.
2. Every 6 months: calibrate, functional test, clean and inspect for damage.
3. Every 12 months: in addition to the normal 6-month maintenance, service filter, leak test and check adjustments.
4. Every 36 months: in addition to the normal annual service replace all seals, gaskets, soft goods, and batteries.

In addition to the above scheduled maintenance, there are three important areas of user care that will determine the length of service you can expect from your equipment.

1. Take care of your equipment, protect it, and handle it with care during transportation to the job site. Ensure the equipment is protected. Select a work area where the equipment will be out of everyone's way, so that it doesn't get knocked over.
2. Clean your equipment. After the work is done at the job site, clean up the equipment. If you are on an extended work program, have the equipment operators clean the equipment during slow work periods. Cleaning involves wiping off the dirt with hot soapy water and a soft cloth. Soft Scrub, paint thinner, mineral spirits & turpentine can be used, if necessary, to clean only the case. Clean the terminals (diver communicator connections), using a solution of mild vinegar and a small brush.
3. Charge the batteries after each use; preferably leave the unit on charge when the equipment is not in use.

10.2 Scheduled Maintenance

1. Before and after each dive: inspect for any damaged parts, broken gauges, condition of high-pressure hose whip (inspect for cuts, abrasion, or general deterioration). Functional test of unit prior to dive, after dive record operator comments regarding maintenance required.
2. Every 6 Months: complete the before and after each dive inspection. Each diver pneumo gauge must be calibrated. Calibrate against dead weight tester or reference gauge. Pressure test PNEUMO section and repair any and all leaks. Record the results of inspection and gauge calibration.

Every 12 months: complete the above tests plus the following:

1. Remove high-pressure valve stems, inspect, clean, lubricate (use Christolube grease, Amron part No. MCG-111-20Z) and install. Check valve seat, threads, packing material for signs of wear or deterioration, replace if necessary.
2. Remove filter element and inspect. If filter element is dirty, make a determination as to where the contamination is coming from. Check the air source being used to determine where the contamination is coming from and correct. If filter is contaminated, remove high pressure section and clean all valves, inspect for signs of wear and deterioration, replace those parts which show signs of deterioration, clean and reassemble.
3. Check regulator action, check regulator maximum pressure which should be greater than 265 PSI.
4. Check relief valve actuation and shut off. Should vent at 285 PSI, close at 280 PSI sealing bubble tight.
5. Check action of pneumo gauge protectors, should shut off at 122 PSI +/- 5 lbs., on slow rising pressure.
6. Check operation of LOW-PRESSURE alarm, adjust if necessary. Should turn on at 100 PSI +/- 5 lbs., turn off at 110 PSI +/- 5 lbs.
7. Check all valves for bubble tight shut off. Replace seats as needed.
8. Leak test all fittings, Pressure test PNEUMO section.
9. Check accuracy of all gauges.
10. Record the results of the above tests.

Every three years, in addition to the above test:

1. Replace all soft goods, seals, gaskets and batteries.
2. Record the results of the above tests.

11. TROUBLESHOOTING AND REPAIR

11.1 General Information

Normal shop tools and procedures apply for all repairs.

During this section when you are instructed to remove a part or make an adjustment, you are first to remove all pressure from the system, or as a minimum from the section you are working on

11.1.1 Tubing and Tube Fittings

Repair, assembly, and inspection procedures. The common cause of leaks on tube fittings are debris, cracks, and deformed tube flares. Tube fittings, on initial make up tighten 1-1/4 turns from finger tight. To remake tube fittings, tighten finger tight plus 1/8 turn. Care must be used when disassembling tube fittings to ensure the fitting is held while the tube nut is turned.

11.1.2 Pipe Fittings

An over tightened pipe fitting is the most common cause of leaks. Before installing pipe fittings, remove all old Teflon tape, use stiff bristle brush. Replace Teflon tape by wrapping 1-1/2 turns of 1/2 inch tape, counter-clockwise on the threaded portion of the fitting. Use care when installing Teflon tape, leave one full turn of thread exposed and uncovered. This insures that a piece of tape does not get cut off and enter the system during the installation of the fitting.

11.1.3 To Remove a Panel

From the case (either the upper, lower, or communicator), first disconnect the electrical cable from the communicator and the pneumo hose from the lower panel. Turn the MS connector on the communicator counter-clockwise to loosen. When the locking ring is turning free, pull up on the connector to remove. You will also need to remove the air hose connecting the lower panel to the upper panel. Loosen the fitting on the lower panel, use two wrenches, and disconnect the hose.

11.1.4 Remove the Diver Communicator

Before attempting to remove the lower panel, loosen and remove the four screws on the front panel of the communicator. Lift communicator out of panel and set aside. Remove the lower panel by removing the screws from around the perimeter of the panel. The lower panel can now be removed from the case. When the lower panel is removed, the case will want to tip over backwards because of the unbalanced weight, support the upper panel or remove the stay hinge and lay the upper panel down.

11.1.5 Removing the Upper Panel

This is the same procedure as the lower. To install the panel back in the case, install all screws before tightening any of the screws. This allows the panel to be shifted to facilitate the alignment of the screw holes in the panel.

11.2 Air Control

11.2.1 HP Gauges

Inspect for leaks. Any leak other than the input fitting is cause to replace the gauge. Internal leaks may cause the gauge face to bulge, if this occurs replace gauge. Inspect gauge blow-out plug for damage. Check accuracy of gauge against reference gauge. Gauges are not repairable, nor can they be adjusted. Discard and replace if problems are encountered.

11.2.2 HP Valves

These are repairable. Remove stem by removing handle and stem packing nut, unscrew stem. Inspect stem, stem screw threads, valve body screw threads, brass packing washer, Viton O-ring, and stem seat (KEL-F). Repair kits are available and include a complete stem assembly. Lubricate stem screw threads and Viton O-ring with Chris-o-lube grease, install stem assembly, and permanently tighten packing nut.

11.2.3 HP Check Valves

These are repairable. The Maintenance Kit is available from Amron and contains Viton seat and spring. When checking for leaks, be sure to check valve body to end of fitting.

11.2.4 HP Filter

This is a replaceable element. The Maintenance Kit is available from Amron and contains the element, body gasket, and retainer spring. Check with soap and water to ensure filter is not leaking.

11.2.5 HP-Regulator

Problems and their possible causes. Refer to figure while reading this section. If the regulated pressure continues to rise at lock-up with no change in the control knob setting, suspect damaged or dirty main valve seat (item 20) or damaged valve stem (item 18). Bleed inlet pressure and inspect seat and valve stem by removing back cap (item 13), an audible leak through bonnet (item 8). Check torque on bonnet ring (item 6) and diaphragm nut and inspect diaphragm (item 11) for damage or excessive wear. If outlet pressure drops off rapidly with very small flow demand, check that valve stem support (item 22) has not been inadvertently left out after previous disassembly or that filter has not been clogged by and excessively contaminated supply.

11.2.6 Repair Kits

Repair kits are available in two configurations. Soft goods repair kit, P/N 389-6906 includes items 11 diaphragm, 14 "O"-ring, 15 "O"-ring, and 20 seats. The Standard repair kit, P/N 389-6907 includes all the items in the soft goods kit and the following items, 7 washer, and 18 valve stem.

11.2.7 Disassembly and assembly of the Regulator

1. Remove regulator from system.
2. Turn CONTROL KNOB (item 3) counter-clockwise to insure removal of all spring force on the DIAPHRAGM (item 11).
3. Secure regulator in vise with the BACK CAP (item 13) on the bottom.
4. Remove mounting bracket (item 5).
5. Remove BONNET RING (item 6). DIAPHRAGM (item 11) and associated parts can now be disassembled.
6. Remove BACK CAP (item 13) by using 1-1/8" wrench. Valve stem (item 18) and associated parts are removed with the back cap.

The above steps provide the disassembly procedures. To reassemble, simply reverse these procedures. Torque Diaphragm nut to between 45-50 inch pounds, and the Bonnet Ring to between 50-55 foot pounds. Lubricate the "O"-rings, bonnet ring and back cap.

11.2.8 Relief Valve

Check the operation of the vent valve by pressurizing the system until the vent begins to relieve the pressure. Decrease the pressure to stop the venting action, valve should stop bubble tight. If the relief valve does not operate correctly remove and disassemble, inspect. Replace any defective parts or clean, lubricate and reassemble.

To disassemble the relief valve, remove valve from system. In the output side of the valve there is a set screw, remove it. There is a second set screw under the first screw. The second set screw is the actual adjustment for the set point. The first screw is a locking screw that locks the adjusting screw at the set point.

There is another set screw at the other end of the valve, removing this allows the valve to be completely disassembled. When taking the valve apart be sure to lay the parts out in the order in which they were removed to facilitate assembly. Reverse the order to assemble. Pressurize the valve to check the setting of the valve. Remove the pressure and adjust as necessary to set the pressure. Turning the screw clockwise increases the pressure at which the valve will relieve.

11.2.9 LP Input check Valve

Same as the HP check valves except for size. During test, insure that the valve is not leaking by pressurizing the HP section and check the LP input for air leaking out of the input.

11.2.10 Diver's Pressure Gauge

Same as HP pressure gauges.

11.2.11 Diver's Output Valves

¼ turn ball-valves, to test, pressurize the input and turn the valves off, check that no air is leaking past the valve. The valves are repairable. They use Teflon seats which can be

replaced. A maintenance kit is available from Amron. To replace, remove valve from system. Remove end pieces from valve, remove valve stem packing nut and remove stem. Teflon ball seal and stem packing can now be removed and replaced. To assemble, reverse the process.

11.3 Depth Monitoring

11.3.1 Pneumo Valves

Pneumo Valves are repairable. Remove stem by removing handle and step packing nut. Unscrew stem. Inspect stem, stem screw threads, valve body screw threads, brass and Teflon packing washer, and stem seat (KEL-F). Repair kits are available and include a complete stem assembly. Lubricate stem screw threads with Christolube grease, install stem assembly and permanently tighten packing nut.

11.3.2 Pneumo Gauge Protector

Pneumo gauges are not field repairable nor are there any adjustments which can be made in the field. Check to make sure the blow-out plugs are in place. Calibrate every 6 months. Check the zero position of the gauge; a displaced zero is evidence of a gauge that has been subjected to over-pressurization.

11.3.3 Pneumo Gauges

Pneumo gauges are not field repairable nor are there any adjustments which can be made in the field. Check to make sure the blow-out plugs are in place. Calibrate every 6 months. Check the zero position of the gauge, a displaced zero is evidence of a gauge that has been subjected to over-pressurization.

Note: Check the gauge before using. If there is any question about the gauges integrity, have the gauge calibrated. Normal variations in zero are caused by variations in barometric pressure or changes in altitude. These variations normally will not exceed 10 feet.

11.3.4 Low Pressure Alarm

To adjust the set point of the low pressure alarm, loosen the locking ring on the pressure switch. Rotate the body of the switch clockwise to increase the set pressure. The set point of the switch is very sensitive to adjustment and requires patience and a steady hand. Tighten lock and recheck set point. Variation between increasing pressure and decreasing pressure trip points is about 15 PSI. Check the set point in the decreasing direction.

11.4 Diver Communications

11.4.1 Diver Radio Field check Procedures

The following are procedures to allow a functional check in the field of your radio, using only a headset. These steps check all communication functions of the radio in both 2-wire and Full Duplex modes. This means that if your radio checks with these steps, any communication problems should be somewhere else in the system, such as the umbilical, connections, speakers and/or microphone.

11.4.2 Quick Full Duplex Check

1. Identify headset microphone lead and headset earphone lead. Plug into dual banana jack adapters (usually the microphone plug is red).
2. Plug in headset microphone to "Tender" "Microphone" (input) and headset earphone to "Tender" "Headset" (input/output). You should be able to hear yourself talk. This verifies Tender circuit.
3. Move headset microphone to "Diver 1" "Microphone" (input) and headset earphones to "Diver 1" "Earphone" (output). You should be able to hear yourself talk. This verifies Diver 1 circuit.
4. Move headset microphone to "Diver 2" "Microphone" (input) and headset earphones to "Diver 2" "Earphone" (output). You should be able to hear yourself talk. This verifies Diver 2 circuit.

11.4.3 Comprehensive 2-Wire and Full Duplex Check

Set all volume controls at mid-scale, turn power on.

1. Identify headset microphone lead and headset earphone lead. Plug into dual banana jack adapters (usually the microphone plug is red.)
2. Plug headset earphone into "Tender" "Headset" (output) and the headset microphone into "Tender" "Microphone" (input). Turn power on, speaker off. Put on headset and speak into microphone, listening for your own voice. Adjust Diver-to-Tender volume; check that controls respond and that there is adequate volume. If you can talk to yourself, then Tender circuit is operating properly

11.4.4 "Diver 1" Down-link Check

1. Move headset earphone plug from "Headset" (output) to "Microphone" "Diver 1". Talk into headset while pressing the Push-to-Talk switch. You should be able to talk to yourself with plenty of volume as long as the Push-to-Talk switch is depressed. This verifies 2-wire communication from tender to "Diver 1" and the function of relay K1.
2. Move headset earphone plug from "Microphone" (input) "Diver 1" to "Earphone" (output) "Diver 1". Talk into headset. There should be plenty of volume. This checks earphone output for Diver 1, Full Duplex.

11.4.5 "Diver 2" Down link Check

1. Move headset earphone plug from "Diver 1" "Earphone" (output) to "Microphone" (input) "Diver 2". Talk into headset while pressing the Push-to-Talk switch. You should be able to talk to yourself with plenty of volume as long as the "Push-to-Talk switch is depressed. This verifies 2-wire communication from Tender to Diver 2 and the function of relay K2.
2. Move headset earphone plug from "Microphone" (input) "Diver 2" to "Earphone" (output) "Diver 2". Talk into headset. There should be

plenty of volume. This checks earphone output for Diver 2, Full Duplex.

11.4.6 Tender's Speaker Down-link Check

1. Unplug headset from "Microphone" (input) and turn "Speaker" on. Press Push-to-Talk and talk into speaker. You should hear yourself in the headset earphones. This verifies speaker section of relay K1. Turn speaker off.

11.4.7 "Diver 1" Up-link Check

1. Place headset microphone into "Microphone" (input) "Diver 1" and headset earphone plug in "Tender" "Headset" (output). Talk into headset. You should hear yourself in the headphones with plenty of volume. Press "Diver 1" On/Off while talking. When switch is depressed, your voice should cut out. This verifies "Diver 1" "Microphone" (input), relay K1 and "Diver 1 On/Off switch.

11.4.8 "Diver 2" Up-link Check

1. Move headset microphone into "Microphone" (input) "Diver 2". Talk into headset. You should hear yourself in the headphones with plenty of volume. Press "Diver 2" On/Off while talking. When switch is depressed, your voice should cut out. This verifies "Diver 2" "Microphone" (input) relay K1 and "Diver 2" On/Off switch.

11.4.9 Crosstalk Check

1. Move headset microphone plug to "Microphone (input "Diver 1". Press "Crosstalk DV-2 to DV-1 switch and talk into headset. You should hear yourself while the "Crosstalk" switch is depressed. This checks the "Crosstalk" function Diver 2 talking to Diver 1.
2. Move headset microphone plug to "Microphone" (input) "Diver 2"; move headset earphone plug to "Diver 1" "Microphone" (input). Press "Crosstalk 1 to 2" switch and talk into headset. You should hear yourself while the "Crosstalk" switch is depressed. This checks the "Crosstalk" function Diver 1 talking to Diver 2.

11.5 Problems and Their Possible Causes

11.5.1 Unit Does Not Operate

Check to see that unit is turned on (speaker and headset switch). Check that battery condition is okay, (battery condition indicator). Check to see that connections are proper; correct if necessary. Use diver radio field check procedure to determine if problem is within the unit or elsewhere within the communication system. Check to see that internal P.C card connectors are properly seated. There should be no gap between the bottom of the connector housing and the circuit card. Push connector down and recheck.

11.5.2 Low Volume

Check volume control settings, adjust if desired. Check diver connections, correct if bad. Use diver radio field check procedure. Check for low batteries.

11.5.3 Garbled Voice to Diver

The Diver volume to Tender is set too high; reduce volume. Tender's headset is marginal, speaker has water in it and Diver's microphone is marginal, damaged comm cable or connections; substitute with known good units to determine exact problem and correct.

11.5.4 Garbled Voice to Tender

The Diver volume to Tender is set too high; reduce volume. Tender's headset is marginal, speaker has water in it, and Diver's microphone is marginal, damaged comm cable or connections; substitute with known good units to determine exact problem and correct.

11.5.5 Diver Cuts Out

Check for intermittent connection; substitute system components with known good units to determine exact problem and correct fault.

11.5.6 Connections

Most diver communications problems are caused by bad connections. The time spent in making good connections will result in years of good communications. All connections must be soldered to last for any period of time. Copper wire must be tinned as a minimum. It is strongly suggested that dual banana plugs be used for topside connections. This provides a convenient and secure connection which will last for several years if treated with a reasonable amount of care.

All cable splices must be soldered. Splices should be staggered, covered with shrink tubing, preferably shrink tubing with an adhesive sealant, and a general splice cover to protect the connections. Potting of splices is a very good and professional approach, however not necessary to create a reliable splice.

11.5.7 Push-to-Talk Does Not Function but Tender Hears Diver (2-Wire)

Check connection to tender headset microphone if used. Check battery condition indicator to be steady green. The first function to fail because of low batteries is the actuation of the push-to-talk function. Find which push-to-talk switch is not working (PTT All Divers, PTT Diver 1 & PTT Diver 2). It could be a broken wire on the switch terminals or a bad connection with PC card.

11.5.8 Diver Hears Tender but Tender Cannot Hear Diver (or volume is very low)

Check to see if Diver is connected to microphone and not earphone. Check to see that volume levels are not turned down. Inspect Diver connections and hat components.

11.5.9 Feedback

These situations may cause feedback: Tender's speaker on while headset is connected; unused Diver communications connected to system; damaged comm cable or connections (open or shorted wires or connections). Feedback can be caused by leakage between

microphone wires and earphone wires in the umbilical. Leakage can be determined by a continuity test between the wires. Resistance for a new cable should be in excess of 10Meg ohms. In a situation where the comm cable is damaged, reduce the volume to diver as low as possible (reduce side tone), or go to 2-wire operation until cable can be repaired.

11.5.10 Distortion

Distortion may be caused by several conditions: Volume is adjusted too high; system is on the verge of feedback; marginal components (earphone or microphone). Check by substitution, replace defective components. Note: when operating with standby Diver who does not have his helmet / hat on, acoustic feedback or distortion may occur. Correct by turning his volume down or disconnecting his comm cable (at least his microphone, which will reduce overall system noise).

12. REFERENCE MATERIAL

12.1 Diving Log, U.S Navy (Chart)

DIVING CHART - AIR						Date	
NAME OF DIVER 1			DIVING APPARATUS		TYPE DRESS		EGS (PSIG)
NAME OF DIVER 2			DIVING APPARATUS		TYPE DRESS		EGS (PSIG)
TENDERS (DIVER 1)				TENDERS (DIVER 2)			
LEFT SURFACE (LS)		AND DEPTH (fsw)		REACHED BOTTOM (RB)		DESCENT TIME	
LEFT BOTTOM (LB)		TOTAL BOTTOM TIME (TBT)		TABLE & SCHEDULE USED		TIME TO FIRST STOP	
REACHED SURFACE (RS)		TOTAL DECOMPRESSION TIME (TDT)		TOTAL TIME OF DIVE (TTD)		REPETITIVE GROUP	
DESCENT	ASCENT	DEPTH OF STOPS	DECOMPRESSION TIME		TIME		
			WATER	CHAMBER	WATER	CHAMBER	
	↑	10			L		
	↑	20			R		
	↑	30			L		
		40			R		
		50			L		
		60			R		
		70			L		
		80			R		
		90			L		
		100			R		
		110			L		
		120			R		
	↓	130			L		
PURPOSE OF DIVE				REMARKS			
DIVER'S CONDITION				DIVING SUPERVISOR			

12.2 Repetitive Dive Worksheet

REPETITIVE DIVE WORKSHEET

I. PREVIOUS DIVE:

_____ minutes Standard Air Table
 _____ feet No-Decompression Table
 _____ repetitive group designation

II. SURFACE INTERVAL:

_____ hours _____ minutes on surface.
 Repetitive group from I _____
 New repetitive group from surface _____
 Residual Nitrogen Timetable _____

III. RESIDUAL NITROGEN TIME:

_____ feet (depth of repetitive dive)
 New repetitive group from II. _____
 Residual nitrogen time from _____
 Residual Nitrogen Timetable _____

IV. EQUIVALENT SINGLE DIVE TIME:

_____ minutes, residual nitrogen time from III.
 + _____ minutes, actual bottom time of repetitive dive.
 = _____ minutes, equivalent single dive time.

V. DECOMPRESSION FOR REPETITIVE DIVE:

_____ minutes, equivalent single dive time from IV.
 _____ feet, depth of repetitive dive

Decompression from (check one):

- Standard Air Table No-Decompression Table
 Surface Table Using Oxygen Surface Table Using Air
 No decompression required

Decompression Stops: _____ feet _____ minutes
 _____ feet _____ minutes
 _____ feet _____ minutes
 _____ feet _____ minutes
 _____ feet _____ minutes

Scheduled used _____
 Repetitive group _____

12.3 No Decompression Limits

(Non-repetitive Dives Only) U.S. Navy Diving Manual (Air Decompression)

Depth FSW	Bottom Time
40	200
50	100
60	60
70	50
80	40
90	30
100	25
110	20
120	15
130	10
140	10
150	5
160	5
170	5
180	5
190	5

NOTE: OSHA Regulations Require: A decompression chamber capable of recompressing the Diver at the surface to a minimum of 165 FSW (6ATA) and shall be available at the dive location for: A) surface supplied air-diving to depths deeper than 100 FSW.

12.4 Gauge Pressure for Depth of Seawater & Fresh water

Gauge Pressure in PSI

Depth In	Feet of Fresh Water	Seawater
10	4.33	4.45
20	8.66	8.90
30	12.99	13.35
40	17.32	17.80
50	21.65	22.25
60	25.98	26.70
70	30.31	31.10
80	34.64	35.60
90	38.97	40.05
100	43.30	44.50
110	47.63	48.95
120	51.96	53.40
130	56.29	57.85
140	60.62	62.30
150	64.95	66.75
160	69.28	71.20
170	73.61	75.65
180	77.94	80.10
190	82.27	84.55
200	86.60	89.00

12.5 Equivalent Depths of Seawater & Freshwater

Depth	Equivalent Depth
Feet of Seawater	Feet of Fresh Water
10	10.30
20	20.30
30	30.90
40	41.20
50	51.50
60	61.80
70	72.10
80	82.40
90	92.70
100	103.00
110	113.30
120	123.60
130	133.90
140	144.20
150	154.50
160	164.80
170	175.10
180	185.40
190	195.70
200	206.00

13. DRAWINGS

General

The following drawings illustrate the electrical and mechanical details of the diver communication unit. The corresponding parts lists for each drawing are detailed in the parts lists section.

Revisions

As drawings are updated, information about changes is incorporated into a revision sheet. This revision sheet appears in the manual immediately after the drawings. It lists the drawing number, the reference designator of the part or parts involved, a description of the revision, and the effective serial number of the change. With this information, the technician can determine the correct drawing for the current version and any previous version(s) of the unit covered by this manual. If the revision is applicable for all versions of the unit, it is not included in the revision notice, as the change applies to all units.

13.1 Parts Locator, Model 8225-200 (pneumo Front Panel)

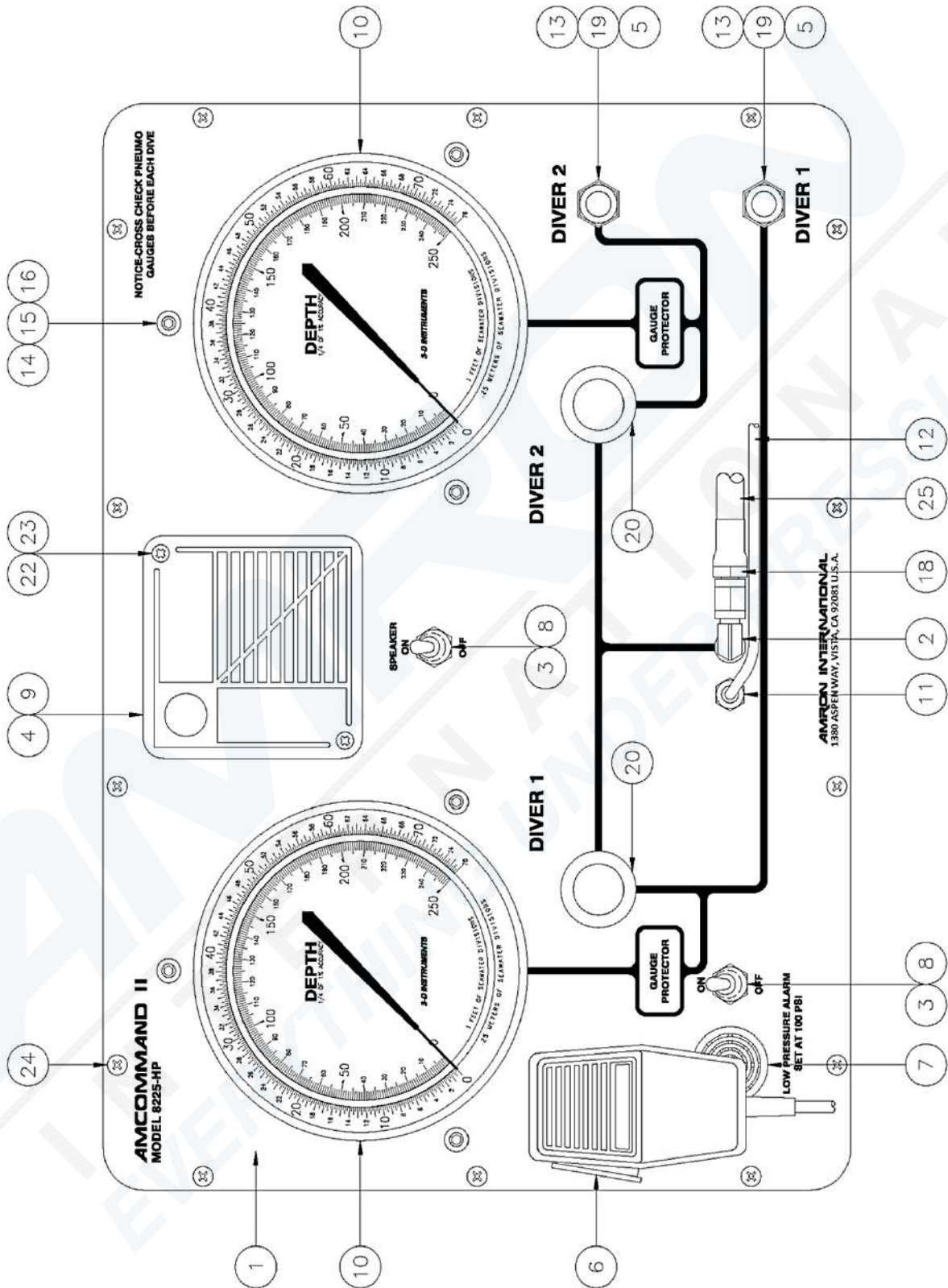

13.2 Parts Locator, Model 8225-200 (Pneumo Back Panel)

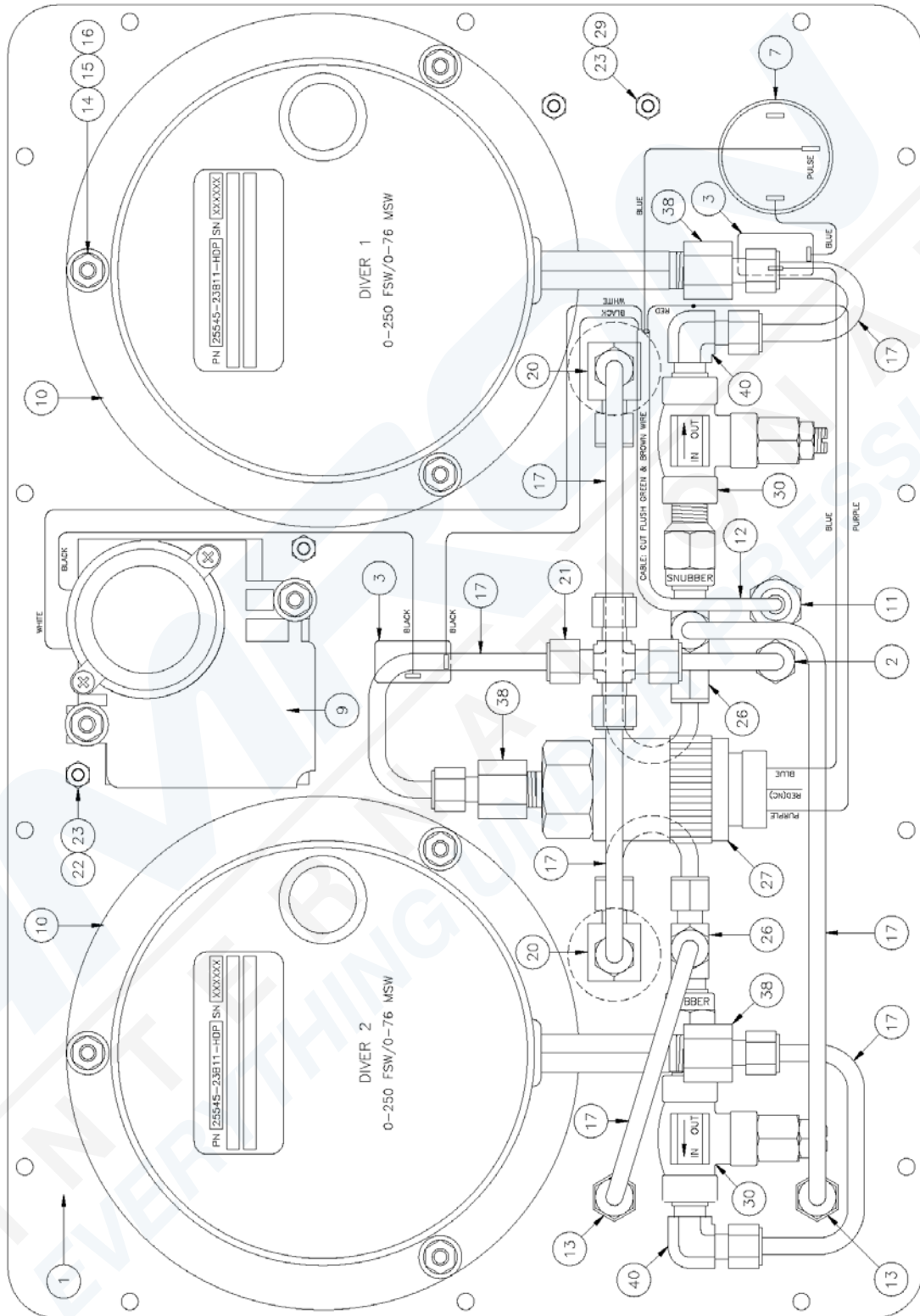

13.3 Parts Locator, Model 8225-400 HP (Air control Front Panel)

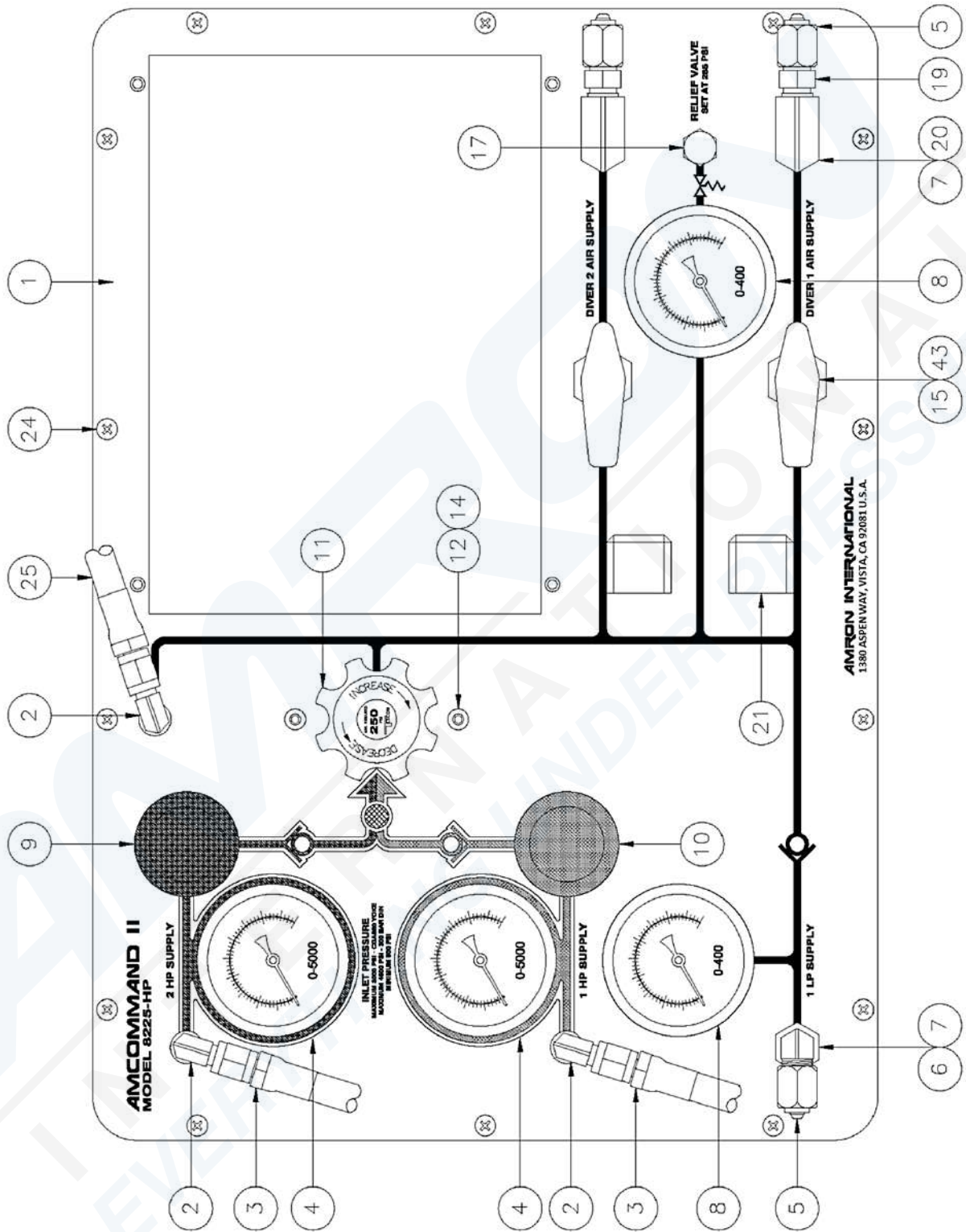

13.4 Parts Locator, Model 8225-400 HP (Air Control Back Panel)

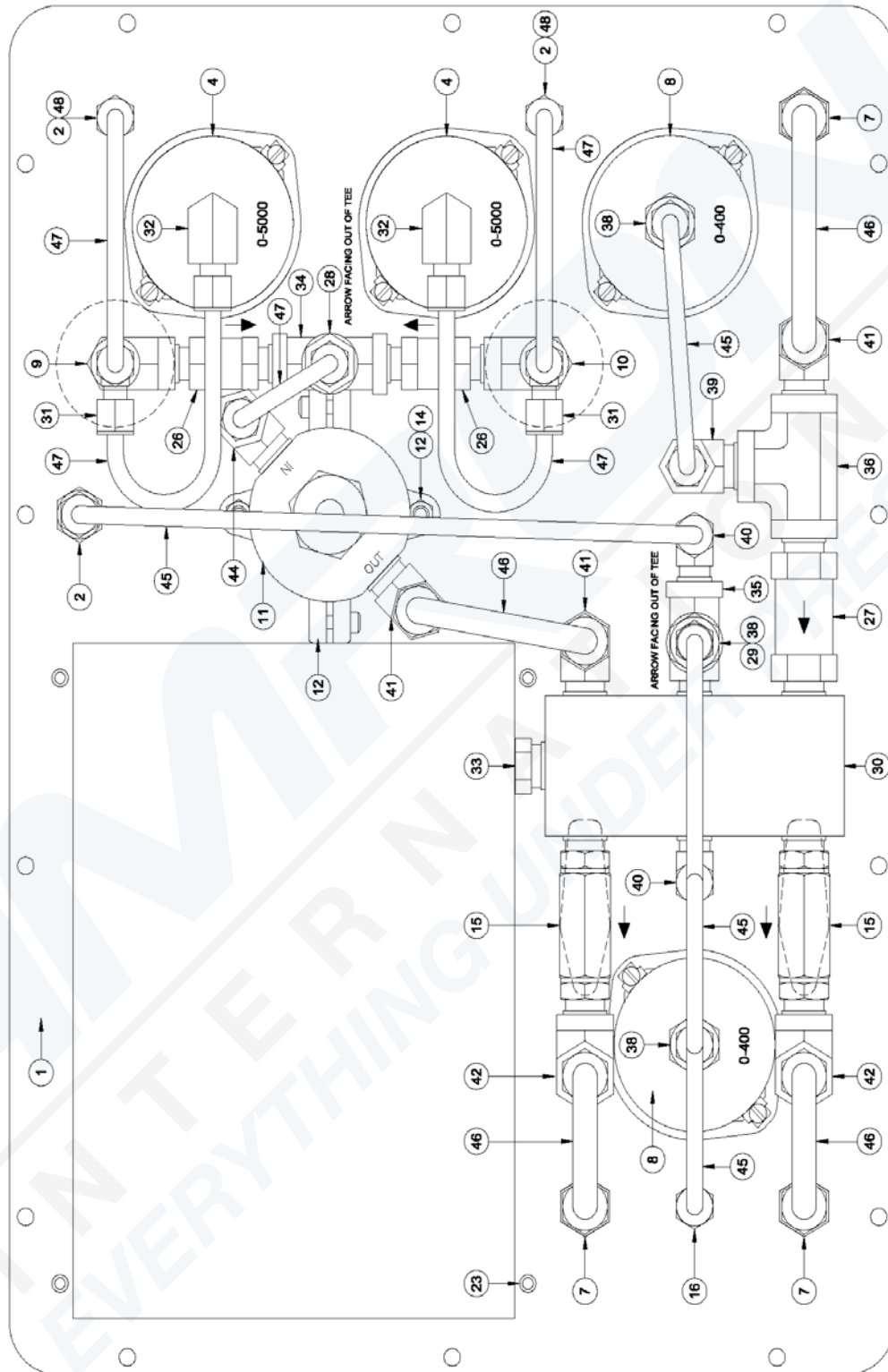

13.5 Parts Locator, Model 8225 HP2 (Air Control Front Panel)

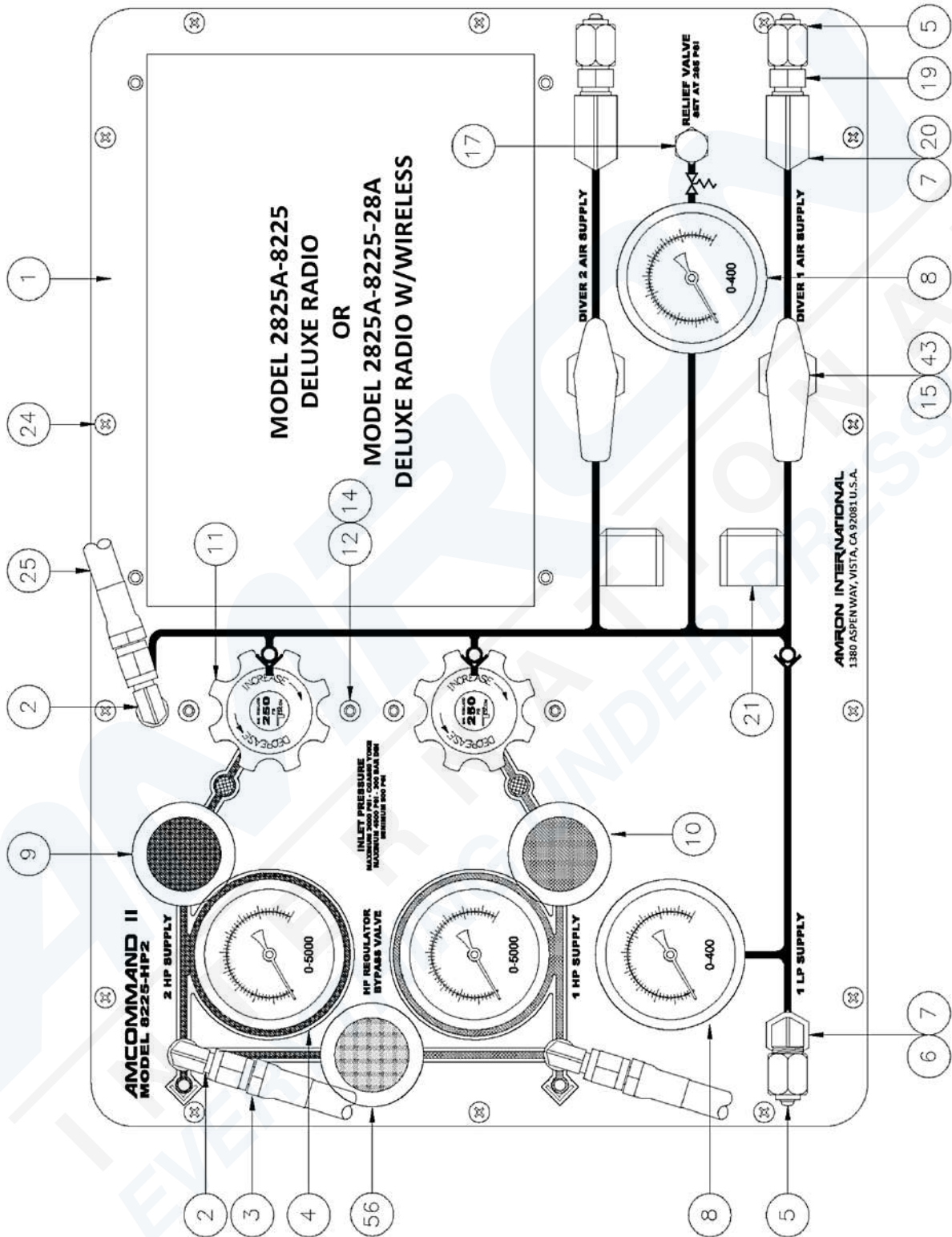

13.6 Parts Locator, Model 8225-400 HP2 (Air Control Back Panel)

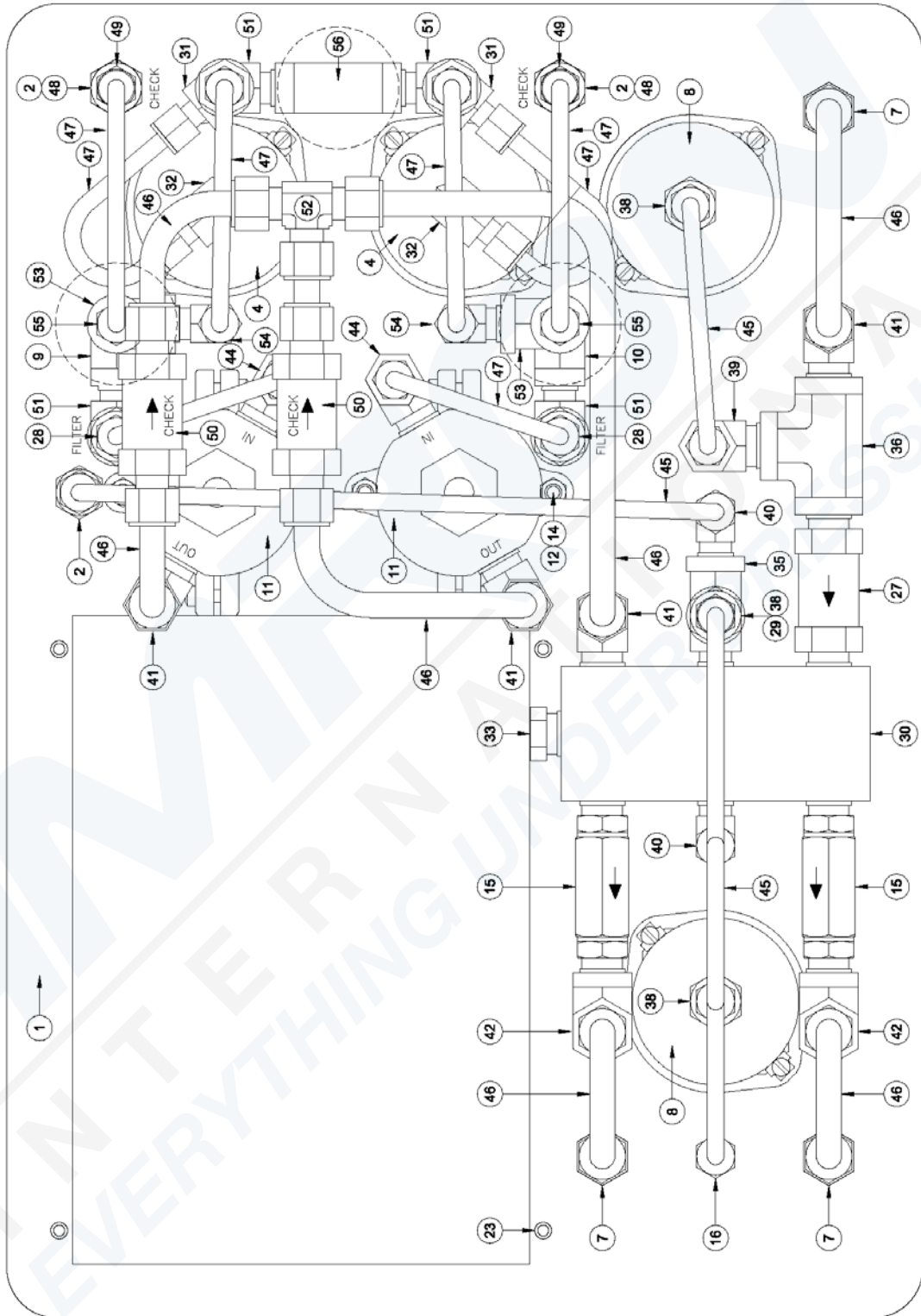

13.7 Parts Locator, Model 2825A-8225-28A (Diver Communications)

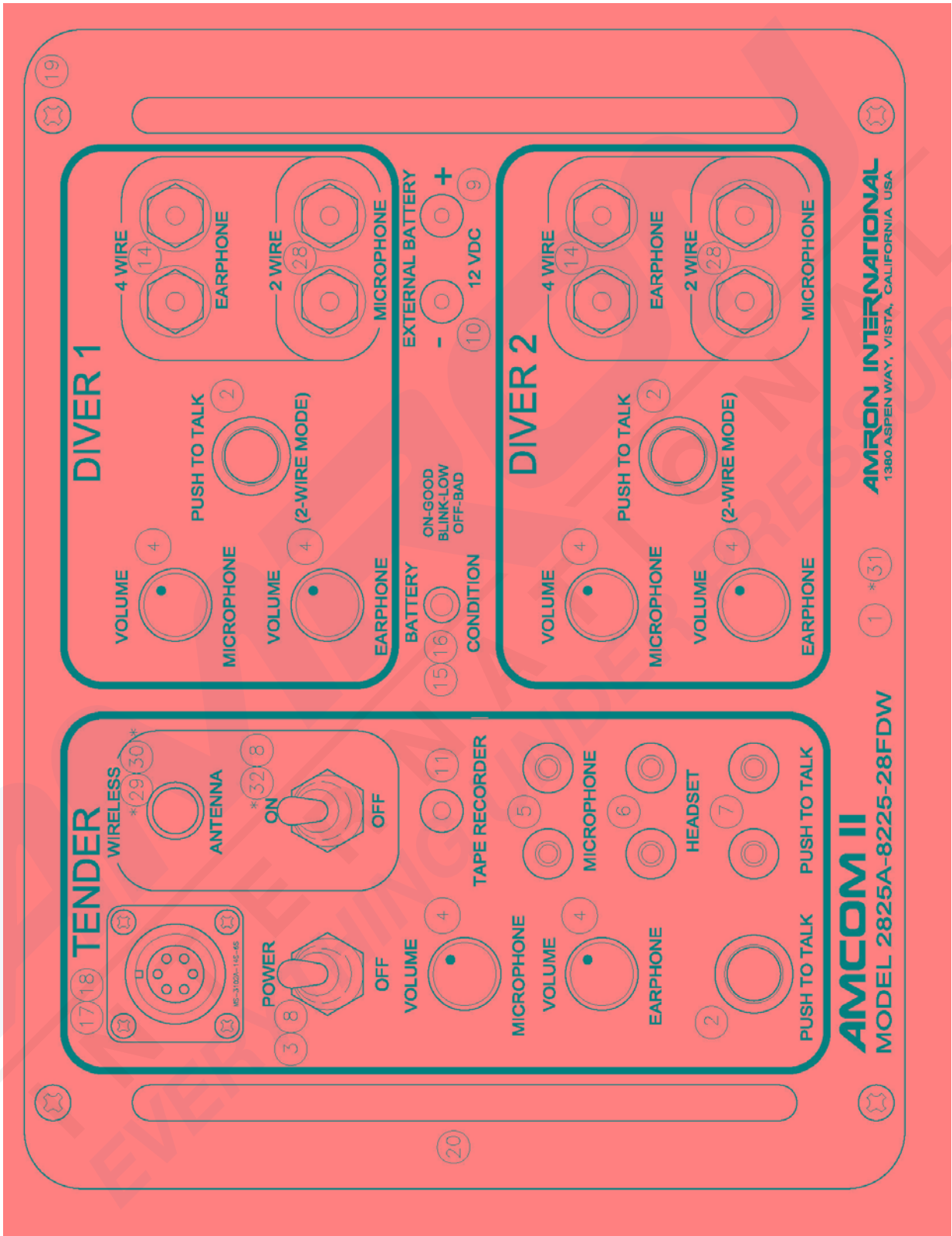

13.8 Parts Locator, Model 8000-0201 (Regulator)

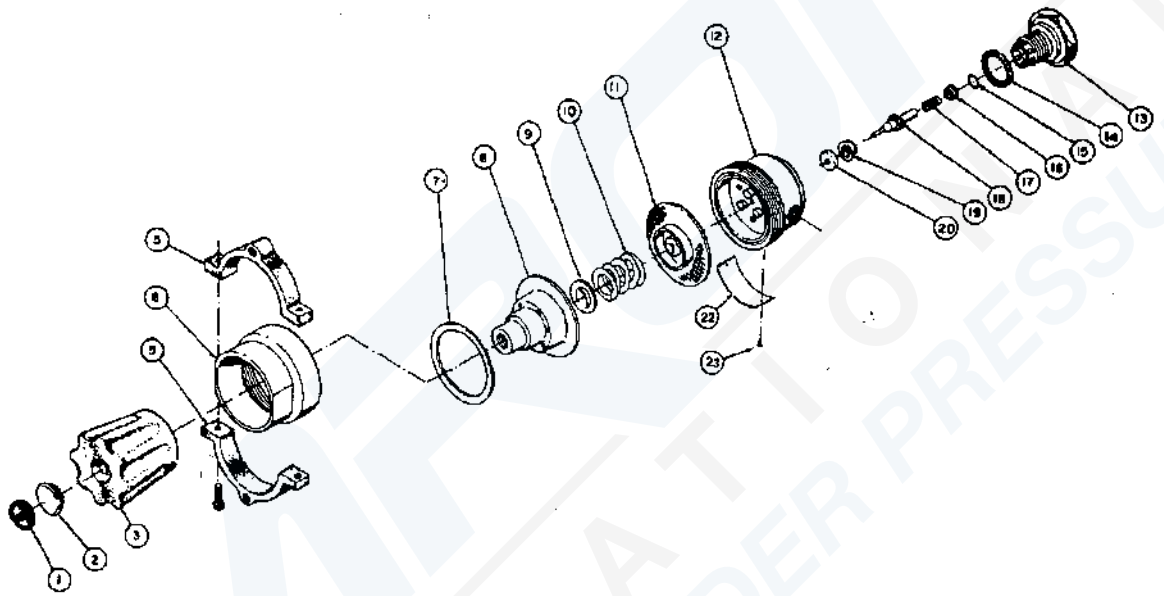

14. PARTS LISTS

General

The following parts lists include all mechanical and electrical parts. The following information will be useful in interpreting data which is not self-explanatory.

Revisions

The parts lists in this manual are for the current model of Diver Communicator as of the printing date. If a different part was used in a previous build, details of the parts change are included in the revision listing sheet. This will enable you to determine the correct replacement part. If the new part is the recommended replacement part for all units, the old part is not listed in the revision listing.

To Order Replacement Parts:

Amron International, Inc

1380 Aspen Way
Vista, CA 92081 USA

Telephone: (760) 208-6500

Fax: (760) 599-3857

Email: sales@amronintl.com

Website: www.amronintl.com

When ordering replacement parts, you should give as much information as possible to enable us to supply the correct part you need. This information should include the reference designator, description value, part number, radio model number, and serial number. Failure to provide sufficient information may result in our inability to fill your parts orders promptly and correctly. Part numbers should always include a description as a double-check for you and us to ensure you are getting the parts you desire.

14.1 AMCOMMAND II Air Control System, Model 8225-HP

Reference	Part No.	Description
N/S	8225-200	Pneumo Panel Assembly
N/S	8225-300	Case, Air Control & Pneumo
N/S	8225-400HP	A/C Panel Assembly, 8225-HP
N/S	8225-500	HP Yoke/Hose Assembly
25	HP4FS16	16IN HP Whip #4 JIC X #4 JIC
N/S	2825A-8225	AMCOM II Deluxe
N/S	2832-202-01	P.C. Card Assembly-Amcom II
6	2405-28	Hand Held Microphone P-T-T
N/S	2823-603	Charger Assembly

14.2 AMCOMMAND II Air Control System, Model 8225-HP2

Reference	Part No.	Description
N/S	8225-200	Pneumo Panel Assembly
N/S	8225-300	Case, Air Control & Pneumo
N/S	8225-400HP2	A/C Panel Assembly, 8225-HP2
N/S	8225-500	HP Yoke/Hose Assembly
25	HP4FS16	16IN HP Whip NO4 JIC X NO4
N/S	2825A-8225	AMCOM II Deluxe Communicator
N/S	2832-202-01	P.C. Card Assembly-Amcom II
6	2405-28	Hand Held Microphone P-T-T
N/S	2823-603	Charger Assembly

14.3 8225-200 Pneumo Panel Assembly

Reference	Part No.	Description
10	25545-23B11-HDP	Gauge Pneumo 6", 250 FSW
20	4Z-V4AK-B-YEL	Valve, Pneumo Shut-off*
8	5168	Switch, Seal Toggle Shaft
3	7580K6	Switch, Toggle SPST
55	8200-016	Cap, Dust with Retainer #6
1	*** NOT FOR SALE ***	Panel, Pneumo
4	8225-006	Cover, Front 8225 Speaker
12	8446	Cable, 6 Conductor 2-18Ga. 4-22
40	CBZ-B-4-4	Elbow, Male, 1/4" x 1/4" NPT, Brass
38	GBZ-B-4-4	Connector, Female 1/4 Brass
13	GH2BZ-B-4-4	Connector, Female Bulkhead 1/4
21	KBZ-B-4	Cross, Union 1/4" Brass
27	96211-BB4	Switch, Pressure 22.5-125 PSI
30	ALV-BL-10-150	Gauge Protector, Adjustable
26	RBZ-B-4-4-4	Tee, Male Run 1/4
25	HP4FS16	HP Whip; #4 JIC X #4 JIC, 16in.
9	SA818	Speaker, 4 ohm/15 watt
7	273-068	Alarm, Audio
2	WEBTX-B-4	Elbow, Bulkhead Union Brass
17	*** NOT FOR SALE ***	Copper Tubing, 1/4"
*	822091-B	Repair Kit for 4Z-V4AK-B-YEL
N/S = Not Shown		
* = Repair Kit		

14.4 8225-400HP Air Control Panel Assembly, Model 8225-HP

Reference	Part No.	Description
1	*** NOT FOR SALE ***	Panel, Front Model 8225
2	WEBTX-B-4	Elbow, Bulkhead Union Brass
3	8225-500	HP Yoke Assembly
4	711725206000	Gauge, 0-6000 PSI w/Clamp
5	8200-016	Cap, Dust with retainer #6
6	VTX-B-6	Elbow, Male 45 Degree body only
7	GH2BZ-B-6-4	Connector, Bulkhead 3/8 Tube x 1/4 FNPT
8	71172520600	Gauge, 0-600 PSI w/Clamp
9	4F-V6AK-V-SS-KRY-LH	Valve, Viton Angle Fem Pipe, Blue*
9	V6-HANDLE-BLUE	V6 Handle Blue
10	4F-V6AK-V-SS-KRY-LH	Valve, Viton Angle Fem Pipe, Red*
10	V6-HANDLE-RED	V6 Handle Red
11	26-1512-26-277	Regulator, Pressure 5000/265
15	6M-B6LJ-BP	Valve, Ball 3/8" MNPT Brass*
16	FBZ-B-4-4	Connector, Male 1/4
17	8600-014	Diffuser, Vent Cap
19	MA-742	Adapter, 02 x 1/4 MNPT Brass Chrome
20	CD-B-1/4	Elbow, Street 90 Degree 1/4 Brass
21	8225-004	Bracket, Yoke for 8225
25	HP4FS16HP	HP Whip; #4 JIC X #4 JIC, 16in.
26	4M-C4L-1/3-SS	Check Valve, S/S, 1/4 MNPT 1/3 PSI*
27	6M-C6L-1-B	Check Valve, Brass, 3/8 MNPT, 1 PSI*
28	4M4Z-F4L-50-SS	Filter, 1/4 50 Micron*
29	4CPA2-150-B	Valve, Relief Adjustable*
30	8225-005	Manifold, A/C Model 8225
31	RBZ-SS-4-4-4	Tee, Male Run 1/4 S/S
32	DBZ-SS-4-4	Elbow, Female, 1/4 S/S
33	HP-B-3/8	Plug, Hex 3/8
34	MMO-SS-1/4	Tee, Female 1/4 S/S
35	MRO-B-1/4	Tee, Street (male on run) 1/4
36	MMO-B-3/8	Tee, Female 3/8 Brass
38	GBZ-B-4-4	Connector, Female 1/4 Brass
39	CBZ-B-4-6	Elbow, Male 1/4 Tube x 3/8 NPT, Brass
40	CBZ-B-4-4	Elbow, Male 1/4 x 1/4 Brass
41	CBZ-B-6-6	Elbow, Male 3/8 Brass
42	DBZ-B-6-6	Elbow, Female 3/8 Brass
43	B6-PANEL-NUT-SS	Panel Nut, #8 Air Control
44	CBZ-SS-4-6	Elbow, Male 1/4 Tube x 3/8 NPT, S/S
45	*** NOT FOR SALE ***	Copper Tubing, Soft, 1/4" x .028 Wall
46	*** NOT FOR SALE ***	Copper Tubing, Soft, 3/8" x .032 Wall
47	*** NOT FOR SALE ***	316L S/S Tubing, 1/4" x .035 Wall
48	AP50C-4	Copper Seal, #4 JIC

14.5 8225-400HP2 Air control Panel Assembly, Model 8225-HP2

Reference	Part No.	Description
1	*** NOT FOR SALE ***	Panel, Front Model 8225-HP2
2	WEBTX-B-4	Elbow, Bulkhead Union Brass
3	8225-500	HP Yoke Assembly
4	711725206000	Gauge, 0-6000 PSI w/Clamp
5	8200-016	Cap, Dust with retainer #6
6	VTX-B-6	Elbow, Male 45 Degree body only
7	GH2BZ-B-6-4	Connector, Bulkhead 3/8 Tube x 1/4 FNPT
8	71172520600	Gauge, 0-600 PSI w/Clamp
9	4F-V6AK-V-SS-KRY-LH	Valve, Viton Angle Fem Pipe, Blue*
9	V6-HANDLE-BLUE	V6 Handle Blue
10	4F-V6AK-V-SS-KRY-LH	Valve, Viton Angle Fem Pipe, Red*
10	V6-HANDLE-RED	V6 Handle Red
11	26-1512-26-277	Regulator, Pressure 5000/265
15	6M-B6LJ-BP	Valve, Ball 3/8" MNPT Brass*
16	FBZ-B-4-4	Connector, Male 1/4
17	8600-014	Diffuser, Vent Cap
19	MA-742	Adapter, 02 x 1/4 MNPT Brass Chrome
20	CD-B-1/4	Elbow, Street 90 Degree 1/4 Brass
21	8225-004	Bracket, Yoke for 8225
25	HP4FS16	HP Whip; #4 JIC X #4 JIC, 16in.
27	6M-C6L-1-B	Check Valve, Brass, 3/8 MNPT, 1 PSI*
28	4M4Z-F4L-50-SS	Filter, 1/4 50 Micron*
29	4CPA2-150-B	Valve, Relief Adjustable*
30	8225-005	Manifold, A/C Model 8225
31	RBZ-SS-4-4-4	Tee, Male Run 1/4 S/S
32	DBZ-SS-4-4	Elbow, Female, 1/4 S/S
32	DBZ-SS-4-4	Elbow, Female, 1/4 S/S
33	HP-B-3/8	Plug, Hex 3/8
34	MMO-SS-1/4	Tee, Female 1/4 S/S
35	MRO-B-1/4	Tee, Street (male on run) 1/4
36	MMO-B-3/8	Tee, Female 3/8 Brass
38	GBZ-B-4-4	Connector, Female 1/4 Brass
39	CBZ-B-4-6	Elbow, Male 1/4 Tube x 3/8 NPT, Brass
40	CBZ-B-4-4	Elbow, Male 1/4 x 1/4 Brass
41	CBZ-B-6-6	Elbow, Male 3/8 Brass
42	DBZ-B-6-6	Elbow, Female 3/8 Brass
43	B6-PANEL-NUT-SS	Panel Nut, #8 Air Control
44	CBZ-SS-4-6	Elbow, Male 1/4 Tube x 3/8 NPT, S/S
45	*** NOT FOR SALE ***	Copper Tubing, Soft, 1/4" x .028 Wall

14.5 8225-400HP2 Air Control Panel Assembly (continued)

Reference	Part No.	Description
46	*** NOT FOR SALE ***	Copper Tubing, Soft, 3/8" x .032 Wall
47	*** NOT FOR SALE ***	316L S/S Tubing, 1/4" x .035 Wall
48	AP50C-4	Copper Seal, #4 JIC
49	4Z-C4L-1/3-SS	Check Valve, S/S, 1/4 CPI 1/3 PSI*
50	6Z-C6L-1-B	Check Valve, S/S, 3/8 CPI, 1 PSI*
51	CD-SS-1/4	Elbow, Street 1/4"NPT, S/S
52	JBZ-B-6-6-6	Tee, 3/8" Tube, Brass
53	MRO-SS-1/4	Tee, Street 1/4"NPT, S/S
54	CBZ-SS-4-4	Elbow, Male 1/4 Tube x 1/4 MNPT, S/S
55	FBZ-SS-4-4	Connector, Male 1/4 Tube x 1/4 MNPT, S/S
*	822188-SS	Repair Kit, for P/N 4FV6AKVSS-B2500-KRY, 4FV6AKVSS-R2500-KRY, 4FV6LKVSS-W2500-KRY
*	802065-4	Repair Kit for Parker P/N B6LJ-B Series Ball Valve
*	802045	Repair Kit, for P/N 4M-C4L-1/3-SS
*	802040	Repair Kit, for P/N 6M-C6L-1-B
*	KIT-F4-50-V	Repair Kit, for P/N 4M4Z-F4L-50-SS
*	389-6906	Soft Goods Kit, for P/N 26-1512-26-277
*	389-6907	Repair Kit, for P/N 26-1512-26-277
N/S = Not Shown		
* = Repair Kit		

14.6 8225-500 Yoke/Hose Assembly

Reference	Part No.	Description
3	72HP	Hose Assembly, 72" HP (5000)
N/S	FTX-B-4-4	Male Connector, #4 JIC x 1/4 MNPT
N/S	9913-02	Yoke & Bleeder Assembly
N/S	RP75-BLUE	Hose Protector, Blue
N/S	RP75-RED	Hose Protector, Red
N/S = Not Shown		

14.7 26-1512-26-277 Regulator, Pressure Reducing

Reference	Part No.	Description
2	8515-250	Plug, Hole
3	1150	Assembly, Control Knob
5	1129	Assembly, Mounting Bracket
6	212-1	Ring, Bonnet
7	1181	Washer
8	1619	Assembly, Bonnet
9	60986	Button, Spring
10	60984	Spring, Load
11	2645	Diaphragm *
12	2821-1	Body, Regulator
13	5180-1	Cap, Back
14	5200-002107	O-ring*
15	5200-000087	O-Ring*
16	1186-6	Retainer, Valve Spring**
17	5378	Spring**
18	5840-6	Stem, Valve**
19	6633	Filter
20	6850	Seat*
	389-6906	Soft Goods Kit (*)
	389-6907	Repair Kit, includes Soft Goods Kit (* & **)

14.8 2825A-8225-400 Front Panel Assembly

Reference	Part No.	Description
1	*NOT AVAILABLE FOR SALE	Panel, Front Amcom II
2	PBSWITCH	Switch, Push Button SPST (mom)
3	7580K6	Switch, Toggle SPST
4	P16NP-10K	Potentiometer, 10K ohms with knobs
5	1498-102	Jack, Banana Red
6	1498-103	Jack, Banana Black
7	1498-107	Jack, Banana Yellow
8	5168	Seal, Half Boot, Toggle
9	105-0602-001	Jack, Tip Red
10	105-0603-001	Jack, Tip Black
11	ME161-2003	RCA Phono Jack
14	14002B	Binding Post, Black
15	LEDHOLDER-BLK.25	Mounting Clip, for 5mm LED
16	LT2462-24-D51	LED, BI-Color Red/Green
17	MS-3102A-14S-6S	MS Connector, Bulkhead 6 Pin Female
20	492	Handle, Round 1.5X5.5X5/16
28	14002R	Binding Post, Red
*29	190-0000-00	Antenna, 2.4GHz
*30	180-1001-00	Cable, RG-316, SMA Plug
*31	*NOT AVAILABLE FOR SALE	Panel, Front with Wireless Tender
*32	7580K6	Switch, Toggle SPST
N/S=Not Shown		
N/A=Not Applicable		
*Wireless Tender (Optional)		

14.9 Recommended Spare Parts

Reference	Part No.	Description
N/S	802045	Repair Kit, for P/N 4M-C4L-1/3-SS
N/S	802065-4	Repair Kit for Parker P/N B6LJ-B Series Ball
N/S	822188-SS	Repair Kit, for P/N 4FV6AKVSS-B2500-KRY, 4FV6AKVSS-R2500-KRY, 4FV6AKVSS-W2500-KRY
N/S	KIT-F4-50-V	Repair Kit, for P/N 4M4Z-F4L-50-SS
N/S	802040	Repair Kit, for P/N 6M-C6L-1-B
N/S	822091-B	Repair Kit for P/N 4Z-V4AK-B-YEL
N/S	389-6906	Soft Goods Kit, for P/N 26-1512-26-277
N/S	389-6907	Repair Kit, for P/N 26-1512-26-277
3	72HP	Hose Assembly, 72" HP (5000)
14	14002B	Binding Post, Black
28	14002R	Binding Post, Red
5	1498-102	Jack, Banana Red
6	1498-103	Jack, Banana Black
7	1498-107	Jack, Banana Yellow
8	5168	Switch, Seal Toggle Shaft
3	7580K6	Switch, Toggle SPST
2	PBSWITCH	Switch, Push Button SPST (mom)
N/S	2890-05	Battery, 12 Volt, 7 Ah
N/S	14001B	Plug, Dual Banana Black
N/S	14001Y	Plug, Dual Banana Yellow
N/S	14001R	Plug, Dual Banana Red
N/S	2832-202-01	Amplifier Card Assembly
N/S	2405-28	Hand Held Microphone P-T-T

