

User Manual  
For  
Amron International, Inc.

**Model 8890-2**  
**Dual Oxygen Treatment Panel**



1380 Aspen Way, Vista California 92081-8349

United States of America

Phone: (760) 208-6500

Fax (760) 599-3857

Email: [sales@amronintl.com](mailto:sales@amronintl.com)

Web: [www.amronintl.com](http://www.amronintl.com)

This manual and the information contained herein are provided for use as an operation and maintenance guide. No license or rights to manufacture, reproduce, or sell either the manual or articles described herein are given. Amron International, Inc. reserves the right to change specifications without notice.

*Copyright© 2025 Amron International, Inc.*



**TABLE OF CONTENTS**

**1 INTRODUCTION AND SPECIFICATIONS ..... 1**

1.1 INTRODUCTION..... 1

1.2 MECHANICAL SPECIFICATIONS ..... 1

1.3 ENCLOSURE ..... 2

1.4 DIMENSIONS (LESS HUMIDIFIER)..... 2

**2 ACCESSORIES ..... 3**

**3 INSTALLATION AND OPERATION..... 4**

3.1 HOOD SUPPLY ..... 4

3.2 HOOD EXHAUST ..... 4

3.3 FRONT PANEL, MODEL 8890-2..... 5

3.4 INSTALLATION OF PANEL & HUMIDIFIER ..... 6

3.5 INSTALLATION OF HOOD ASSEMBLY ..... 6

3.6 INSTALLATION OF MASK ASSEMBLY ..... 6

3.7 DRAWING, MOUNTING OPTIONS..... 7

3.8 DRAWING, SCHEMATIC OF COMPLETE SYSTEM..... 8

3.9 TREATMENT PANEL WITH HOOD ASSEMBLY ..... 9

3.10 DRAWING, TREATMENT PANEL WITH HOOD ASSEMBLY ..... 10

**4 MAINTENANCE AND TROUBLESHOOTING ..... 11**

4.1 GENERAL MAINTENANCE..... 11

4.2 RECOMMENDED MAINTENANCE SCHEDULE ..... 11

4.3 TROUBLESHOOTING ..... 12

**5 DRAWINGS AND SCHEMATICS..... 14**

5.1 PARTS LOCATOR, TREATMENT PANEL (FRONT)..... 15

5.2 PARTS LOCATOR, TREATMENT PANEL (BACK)..... 16

5.3 PARTS LOCATOR, HOOD ASSEMBLY (LESS TREATMENT PANEL)..... 17

5.4 PARTS LOCATOR, MASK ASSEMBLY ..... 17

5.5 FLOW DIAGRAM ..... 18

**6 PARTS LIST GENERAL..... 19**

6.1 MODEL 8890-2 OXYGEN TREATMENT PANEL..... 20

6.2 MODEL 8890-102 OXYGEN HOOD SYSTEM WITH TUBING & HUMIDIFIER ..... 20

6.3 RECOMMENDED SPARES..... 21

**7 LIMITED WARRANTY AND SERVICE POLICY..... 22**

## 1 INTRODUCTION AND SPECIFICATIONS

### 1.1 INTRODUCTION

The Model 8890-2, Hyperbaric Oxygen Dual Treatment Panel, is easy to use, and provides control and administration of oxygen within the chamber to an Amron oxygen treatment hood, lightweight face seal or Avox Pressur Vak II™ face seal.

The panel is installed in the chamber and easily connected to the reduced chamber oxygen supply system. The panel's oxygen supply line may be connected in the supply port of the Amron BIBS Manifold, Model 8000-004, if the supply pressure is less than 100 PSI. This allows flexibility when full patient treatment necessitates the use of both the Oxygen Treatment Panel System and the Amron BIBS Mask System.

The Model 8890-2 panel allows you to manually control the oxygen supply, humidification of oxygen, and exhaust flow to the patient wearing an oxygen treatment hood or an oxygen mask. The Model 8890-2 Oxygen Treatment Panel can be used in conjunction with Amron Hoods and hood assemblies. Amron's Hood Assemblies are supplied with a Hood, humidifier, and the necessary tubing & fittings for a quick and easy set-up of the system.

The disposable Humidifier is an inexpensive unit designed for single patient use. This unit incorporates a fine-pore diffusing element that provides for an effective gas/liquid interface for humidification. The humidifier's jar has a large, wide mouth for easy filling and cleaning. The unit is of a durable, shatter-resistant construction with a 2-PSI pressure relief valve.

If you wish to use the Avox Pressur Vak II face seal in your system, a special adapter (P/N 8890-005) is available.

### 1.2 MECHANICAL SPECIFICATIONS

Input Pressure Range.....	15 PSI Over Chamber Pressure to 100 PSI
Max. Pressure.....	100 PSI
Supply Inlet Fitting (1/4 in. CPI).....	1 ea.
Hood Supply On/Off Valve (1/4 Turn Ball Valve) .....	2 ea.
Hood Supply Flowmeter (5-50 LPM) .....	2 ea.
Supply Outlet Connection (22 MM O.D.) .....	2 ea.
Humidifier Supply Flowmeter (.6-5 LPM) .....	2 ea.
Humidifier Outlet Connection (02 Fitting) .....	2 ea.
Exhaust Inlet Connection (22 MM O.D.) .....	2 ea.
Exhaust Flow Control Valve (Needle Valve) .....	2 ea.
Hood Exhaust On/Off Valve (1/4 Turn Ball Valve) .....	2 ea.
Exhaust Outlet Fitting (1/2 in. CPI type) .....	2 ea.

**1.3 ENCLOSURE**

Material ..... Aluminum  
Finish ..... Polyester Powder Coating  
Graphics ..... Silk-Screened, Two Color  
Color ..... Gray

**1.4 DIMENSIONS (LESS HUMIDIFIER)**

Width ..... 15.5in.  
Height ..... 9.1 in.  
Depth ..... 2.0 in.  
Weight ..... 6.5 lbs.

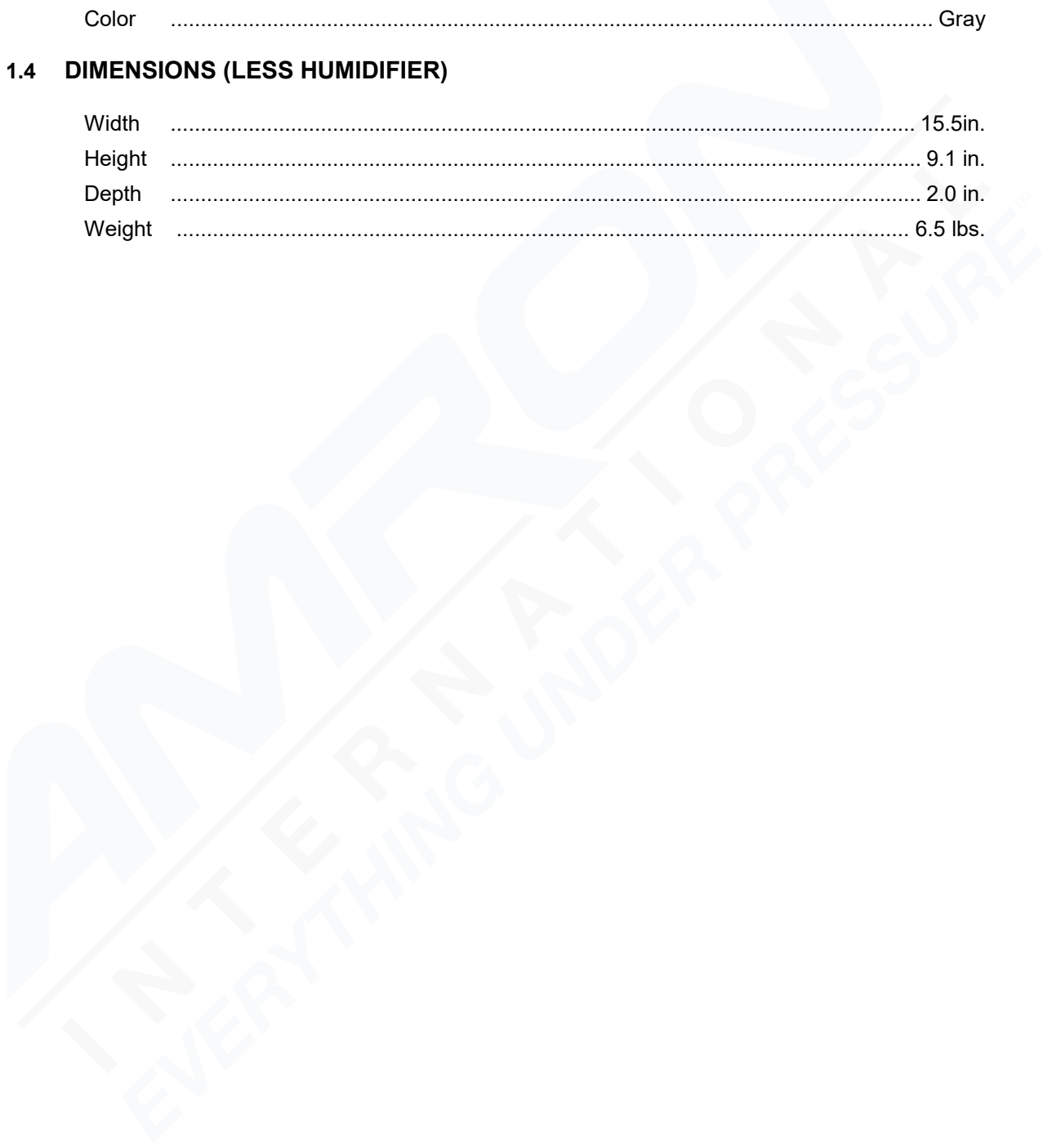

## 2 ACCESSORIES

The following accessories are available to be used with the 8890 Oxygen Treatment Panel and can be ordered at any time.

8890-102	8891-03 Oxygen Hood Assembly with untrimmed silicone neck seal comes complete with all necessary tubing, adapters and humidifier. Just attach to treatment panel and hood assembly is ready to use.
8890-005	Special adapter for use with the Avox Pressure Vak II Face seal when using the oxygen face mask assembly system.
8890-0063	The disposable humidifier is designed for single patient use. This model is ideal for situations requiring isolation environments. The disposable jar has a large, wide mouth for easy filling and cleaning. The unit is of a durable, shatter-resistant construction with a 2-PSI pressure relief valve.
803152-XX	Avox Pressur Vak II Face Seal (adult sizes only) <ul style="list-style-type: none"><li>▪ 803152-05 Extra Small</li><li>▪ 803152-01 Small</li><li>▪ 803152-02 Medium</li><li>▪ 803152-03 Large</li><li>▪ 803152-04 Extra Large</li></ul>
8891-03	Hood Assembly Complete with Untrimmed Silicone Neck Seal
8891-010	Hood with Optical Quality Window
8891-009-00	Silicone Neck Seal, Untrimmed
8891-006	Torso Seal
8891-011	Neck Ring
8891-15	O-ring for Neck Ring
8891-25	Multi-purpose Plug
8891-50	Silencer, Inlet Noise Reducer
8890-300	Exhaust Regulator Adapter Kit
1640	Straight Adapter, 22 mm
1641	Street Elbow Adapter, 90 °, 22 mm
1680	Flex Tubing, 22 mm
MCG-111-2OZ	Oxygen Compatible Lubricant, Christolube (2 oz. Tube)

### 3 INSTALLATION AND OPERATION

Before using the oxygen treatment panel, familiarize yourself with its operating controls and connections. For simplicity, the controls and connections are divided into two categories; hood supply and hood exhaust.

#### 3.1 HOOD SUPPLY

**3.1.1 Oxygen Supply Inlet Fitting:**

1/4" CPI type fitting (various type and size fittings are available upon request).

**3.1.2 Hood Supply On/Off Valve:**

1/4 turn ball valve is main oxygen supply control valve to stop all supply flow and allows flowmeters to be preset.

**3.1.3 Hood Supply Flowmeter:**

Controls oxygen flow to hood or face mask. The flow range is 5 to 50 LPM.

**3.1.4 Supply Outlet Connection:**

22mm O.D. Teflon connector accommodates flex tubing to hood or face mask assembly.

**3.1.5 Humidifier Supply Flowmeter:**

Controls oxygen flow to humidifier. The flow range is .6 to 5 LPM.

**3.1.6 Humidifier Outlet Connection:**

Oxygen type fitting for mating with humidifier.

#### 3.2 HOOD EXHAUST

**3.2.1 Exhaust Inlet Connection:**

22mm O.D. Teflon connector accommodates flex tubing from hood or face mask assembly.

**3.2.2 Exhaust Flow Control Valve:**

Needle valve controls amount of exhaust flow to be vented.

**3.2.3 Hood Exhaust On/Off Valve:**

1/4 turn ball valve is main exhaust control valve to stop all exhaust flow and allows exhaust flow control valve to be preset.

**3.2.4 Exhaust Outlet Fitting:**

1/2" CPI type fitting (Various type and size fittings available upon request).

**3.3 FRONT PANEL, MODEL 8890-2**

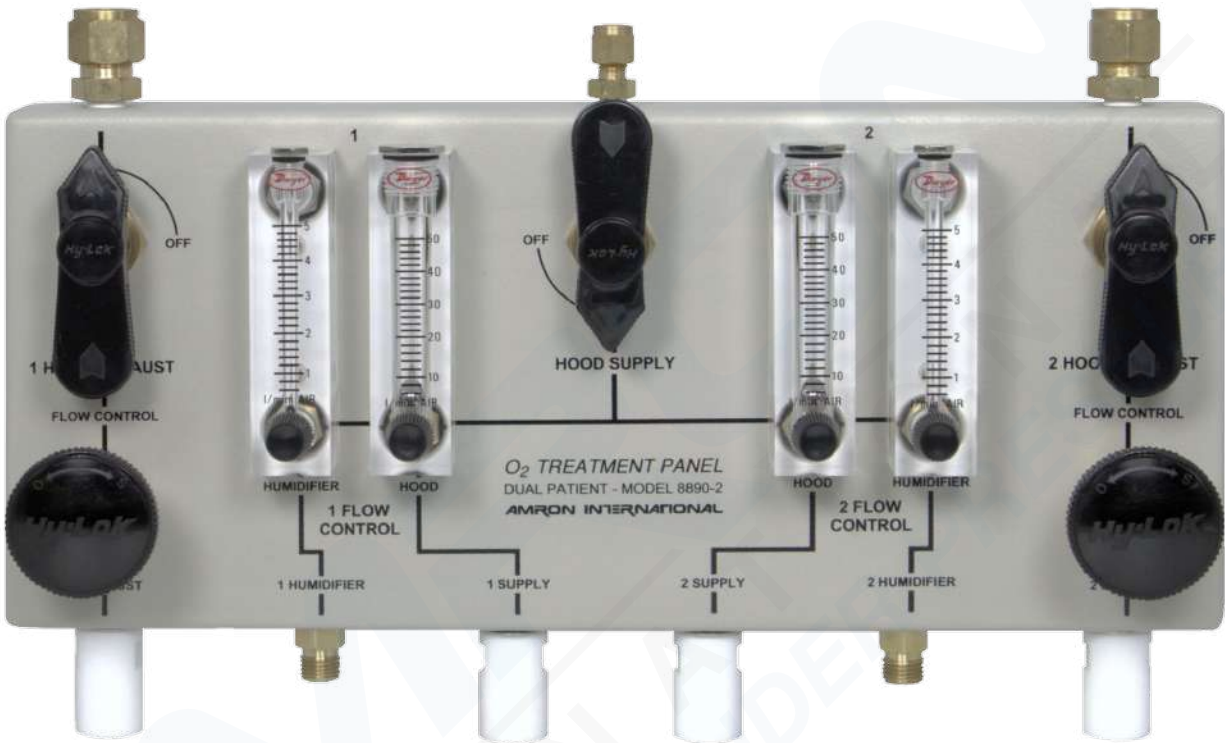



### 3.4 INSTALLATION OF PANEL & HUMIDIFIER

- 3.4.1 Mount treatment Panel securely keeping the flow meters perpendicular to chamber floor to ensure accurate performance.
- 3.4.2 Connect chamber oxygen supply line (less than 100 PSI) to supply inlet fitting on treatment panel. The chamber oxygen line is to be 1/4" O.D. Copper or stainless steel with a working pressure greater than 100 PSI. The chamber oxygen supply line from treatment panel may be connected to the Amron BIBS Manifold if the pressure to manifold block is less than 100 PSI. (For more details, refer to schematic drawing in section 6.2)
- 3.4.3 Connect exhaust line from exhaust outlet fitting on treatment panel to a hull penetrator used for exhaust only. Install a hull stop ball valve on outside of chamber using same hull penetrator for exhaust outside the chamber. Run exhausted gas outside the building. The exhaust line is to be 1/2" O.D. copper or stainless steel with a working pressure greater than 100 PSI. (For more details, refer to schematic drawing in section 6.2).
- 3.4.4 Connect humidifier to oxygen fitting, labeled "HUMIDIFIER".
- 3.4.5 Fill humidifier to proper level using distilled, sterilized or potable water unless otherwise instructed by a physician.

### 3.5 INSTALLATION OF HOOD ASSEMBLY

- 3.5.1 Connect 1/4 in. ID oxygen tubing from line adapter tee to humidifier output.
- 3.5.2 Connect 22mm line adapter tee to supply outlet connection.
- 3.5.3 Connect oxygen supply and exhaust flex tubing connectors to the 22 mm mating connections located on neck ring. The supply and exhaust connectors may be attached to either connection when using the Amron Oxygen Treatment Hood. Optional 90-degree elbows are available from Amron.

**NOTE: OTHER MANUFACTURED HOODS VARY. PLEASE REFER TO THE MANUFACTURER'S LITERATURE FOR PROPER INSTALLATION AND OPERATING PROCEDURES.**

### 3.6 INSTALLATION OF MASK ASSEMBLY

- 3.6.1 Connect 1/4 in. ID oxygen tubing from line adapter tee to humidifier output.
- 3.6.2 Connect 22mm multi-access Tee (labeled "Supply") to supply output connection. Note -Arrow on one-way valve to point toward parallel wye.
- 3.6.3 Connect 22mm multi-access tee (labeled "Exhaust") to exhaust inlet connection. Note -Arrow on one-way valve to point away from parallel wye.

3.7 DRAWING, MOUNTING OPTIONS

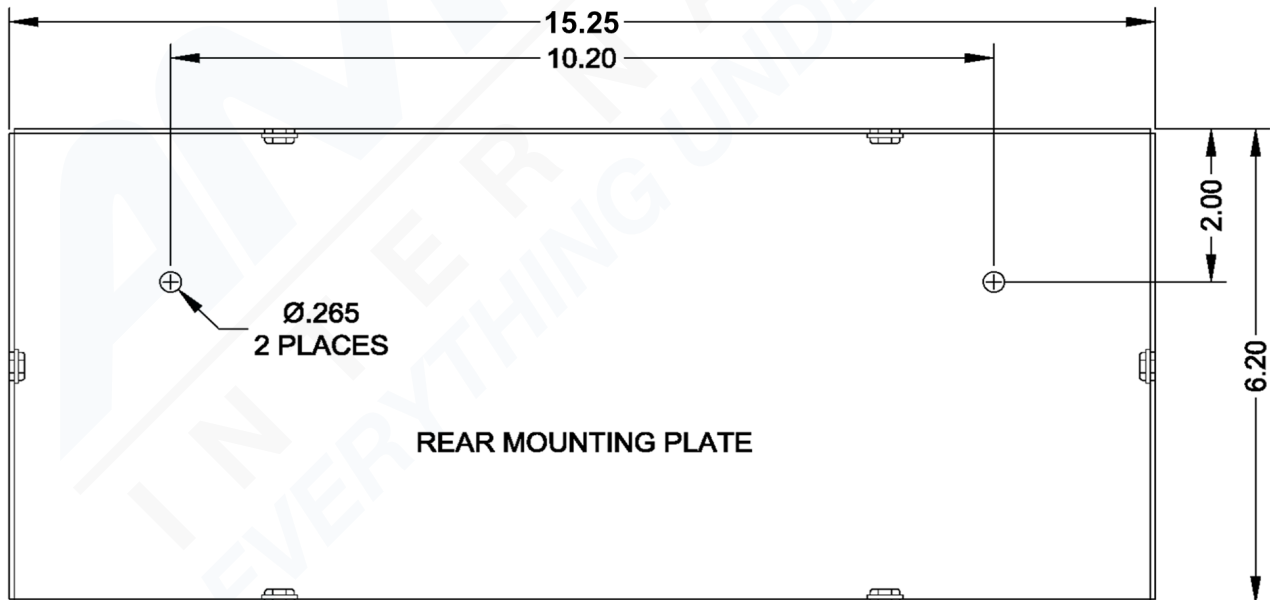
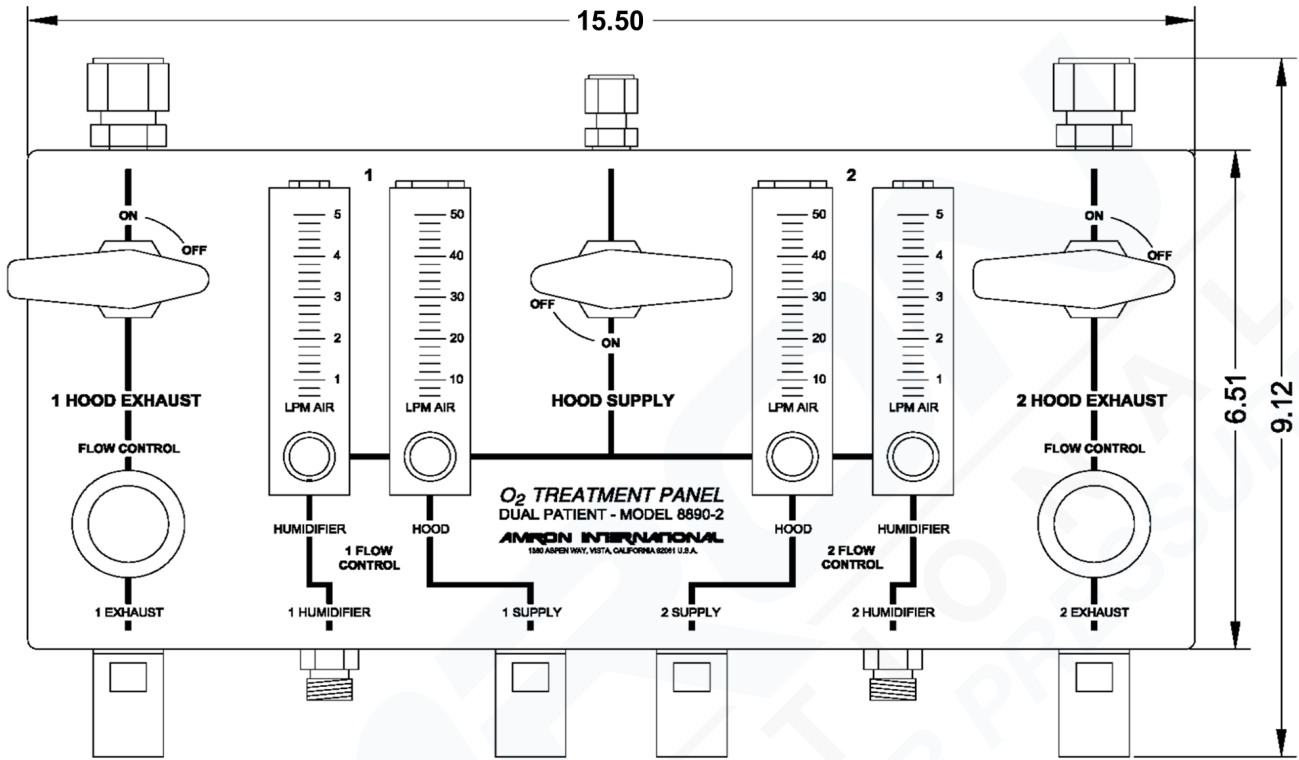

**3.8 DRAWING, SCHEMATIC OF COMPLETE SYSTEM**

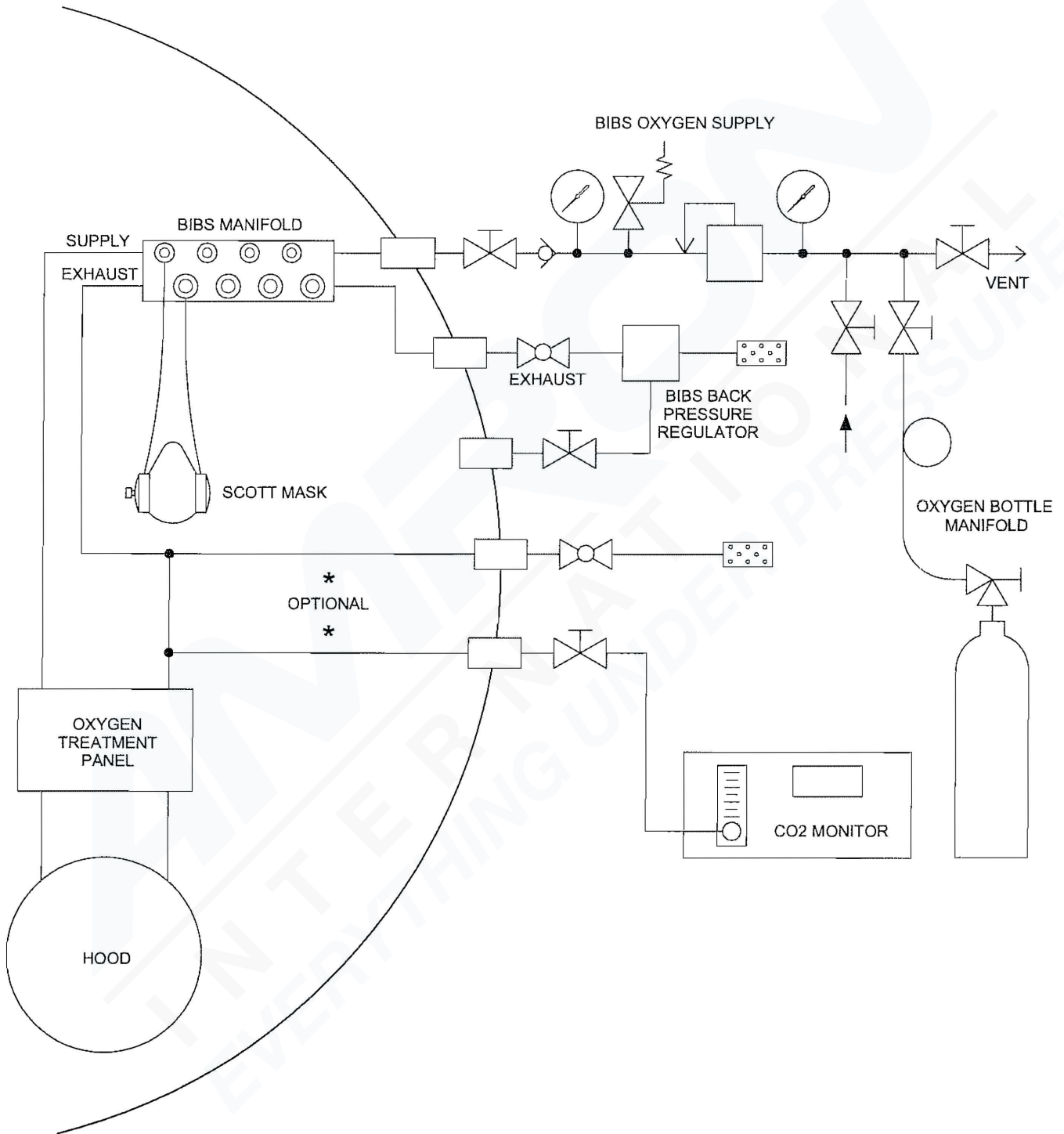

**3.9 TREATMENT PANEL WITH HOOD ASSEMBLY**

- 3.9.1 Connect humidifier to oxygen fitting labeled "Humidifier".
- 3.9.2 Connect 1/4 in. ID oxygen tubing from line adapter tee to humidifier output.
- 3.9.3 Connect 22 mm I.D. from line adapter tee to supply outlet connection.
- 3.9.4 Connect oxygen supply and exhaust flex tubing connectors to the 22 mm mating connections located on neck ring. The supply and exhaust connectors may be attached to either connection when using the Amron Oxygen Treatment Hood. Optional 90 degree elbows are available from Amron.

**NOTE: OTHER MANUFACTURED HOODS VARY. PLEASE REFER TO THE MANUFACTURER'S LITERATURE FOR PROPER INSTALLATION AND OPERATING PROCEDURES.**

- 3.9.5 Fill humidifier to proper level using distilled, sterilized or potable water unless otherwise instructed by a physician.
- 3.9.6 Turn "Hood Supply" and "Hood Exhaust" valves to "OFF" position.
- 3.9.7 Turn on both chamber oxygen supply and exhaust hull stop ball valves located on outside of chamber.

**NOTE: CHAMBER OXYGEN SUPPLY IS NOT TO EXCEED 100 PSI.**

- 3.9.8 Mount neck ring assembly over head of patient.
- 3.9.9 Turn "Hood Supply" and "Hood Exhaust" valves to "ON" position.
- 3.9.10 Open (approx. 1 turn) EXHAUST FLOW CONTROL VALVE.
- 3.9.11 Adjust "Hood Flow Control" flow meter between 25-40 liters per minute.

**PLEASE NOTE: FLOW RATES WILL VARY WITH CHAMBER, DELIVERY SYSTEM, PATIENT TIDAL VOLUME AND BREATHING RATE. PROPER O<sub>2</sub> AND CO<sub>2</sub> LEVELS ARE TO BE VERIFIED WITHIN THE HOOD THROUGH THE MULTIPURPOSE PORT.**

- 3.9.12 Adjust "Humidifier Flow Control" flow meter to mid-scale.
- 3.9.13 Mount the hood to neck dam and adjust the supply and exhaust flow controls to stabilize hood pressure. Note: Excessive flow will over inflate the hood, and insufficient flow will collapse the hood.
- 3.9.14 When terminating use of treatment panel and hood, simply remove hood from patient.
- 3.9.15 To secure system, turn off main oxygen valve and main exhaust valve.

**3.10 DRAWING, TREATMENT PANEL WITH HOOD ASSEMBLY**

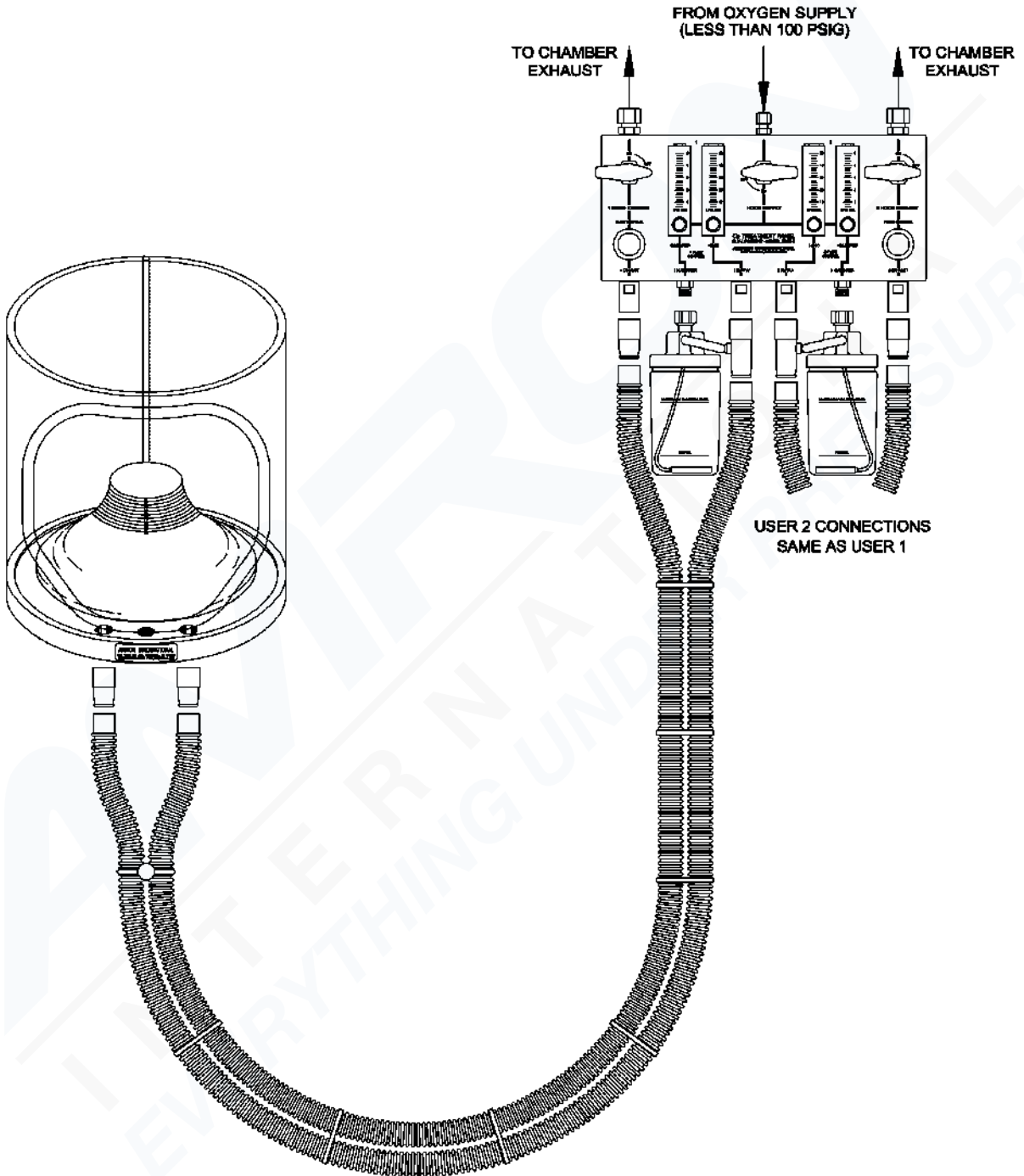

## 4 MAINTENANCE AND TROUBLESHOOTING

The following section describes the procedures for checking the operation of your Oxygen Treatment Panel, general maintenance procedures, and how to troubleshoot common problems.

### 4.1 GENERAL MAINTENANCE

The Oxygen Treatment Panel is designed to provide years of continuous, failure-free service when properly used and maintained. There are a few important things that the user can do to extend the life of their equipment.

1. Handle the Oxygen Treatment Panel with care.
2. Clean your equipment. Cleaning involves the use of a clean damp cloth to wipe the treatment panel, connections, flex tubing, hood/neck seal and mask etc.

### 4.2 RECOMMENDED MAINTENANCE SCHEDULE

The following sections outline the recommended scheduled maintenance for the Oxygen Treatment Panel

#### 4.2.1 DAILY MAINTENANCE

- Before and after use of Treatment Panel, inspect for any damaged parts (inspect for cuts, abrasion, and general deterioration).
- Do a functional test prior to use, to assure proper performance of system.
- After use of Treatment Panel, record operator comments regarding maintenance required.
- Clean your equipment as previously stated.

**NOTE: If equipment has been cleaned with a hospital approved germicidal disinfectant, be sure to rinse and dry completely.**

- The o-ring located on the neck ring of hood has been lightly coated with an oxygen-compatible Christolube lubricant to aid in the mating of the hood to the neck ring. For ordering information regarding the Christolube Lubricant, refer to Options and Accessories section.
- 

#### 4.2.2 YEARLY MAINTENANCE

- Remove valve stem from EXHAUST FLOW CONTROL VALVE and inspect, clean, lubricate (use Halocarbon grease) and install. Check valve seat, threads, and packing material for signs of wear or deterioration and replace if necessary.
- Check all valves for bubble tight shut off. Replace seats as needed.
- Leak test all fittings and connections.

- The Dwyer flowmeters are calibrated at the factory. If at a time during the meter's life, you wish to recheck its calibration, do so only with devices of certified accuracy. DO NOT attempt to check flowmeters with a similar flowmeter as seemingly unimportant variations in piping and back pressure may cause noticeable differences in the indicated reading.

#### **4.2.3 36 MONTH MAINTENANCE**

- Replace all soft goods, seals and gaskets.
- Record the results of the above tests.

### **4.3 TROUBLESHOOTING**

Most problems are usually simple issues that can often be found by careful inspection of the equipment. The following section will describe the troubleshooting procedure for several common issues.

#### **4.3.1 No Oxygen Supply to Hood or Mask**

Turn Hood Supply Valve in the "ON" position Crack open Hood and Humidifier Flowmeters. Check at hood or mask for oxygen flow.

Check to be sure main oxygen supply is turned on and reading correct pressure.

Check all connections for proper installation.

#### **4.3.2 No Oxygen Exhaust from Hood or Mask**

Turn Hood Exhaust Valve in the "ON" position. Crack open Exhaust Flow Control Valve. Check at hood or mask for exhaust flow.

Check that Outside Exhaust Valve is in the "ON" position.

Check all connections for proper installation.

#### **4.3.3 Over Inflation of Hood**

Over inflation of hood is caused from excessive flow. Adjust both flowmeters to mid-scale and check hood exhaust flex tubing for any kinks. If excessive flow continues, open Exhaust Flow Control Valve by turning handle counter-clockwise to increase exhaust flow. If over inflation persists, decrease the flow from Hood Supply Flowmeters by turning knob clockwise. If the problem still exists, check that Outside Chamber Exhaust Valve is in the "ON" position.

#### **4.3.4 Collapsing of Hood**

Insufficient flow will collapse the hood. Adjust both flowmeters to mid-scale and check hood supply flex tubing for any kinks. Check for leaks where Neck Ring to Hood Ring mate. If insufficient flow continues, decrease Exhaust Flow Control Valve by turning handle clockwise.

#### 4.3.5 Humidifier Malfunction

Test Humidifier for leaks and safety valve operation by setting flow of oxygen to 3 LPM and occluding the Humidifier outlet. If safety valve does not activate or appreciable leakage is observed, check that the jar is secure to the Humidifier lid, and that the fitting to the oxygen source is tight.



## 5 DRAWINGS AND SCHEMATICS

The following drawings illustrate the mechanical details of the Amron Oxygen Treatment Panel and associated parts. The corresponding parts lists for each drawing are detailed in the parts lists section.

### Revisions

As drawings are updated, information about changes is incorporated into a revision sheet. This revision sheet appears in the manual immediately after the drawings. It lists the drawing number, reference designator of the part or parts involved a description of the revision, and the effective serial number of the change. With this information the technician can determine the correct drawing for the current version, and any previous version, of the unit covered by this manual. If the revision is applicable for all versions of the unit, it is not included in the revision notice, as the change applies to all units.

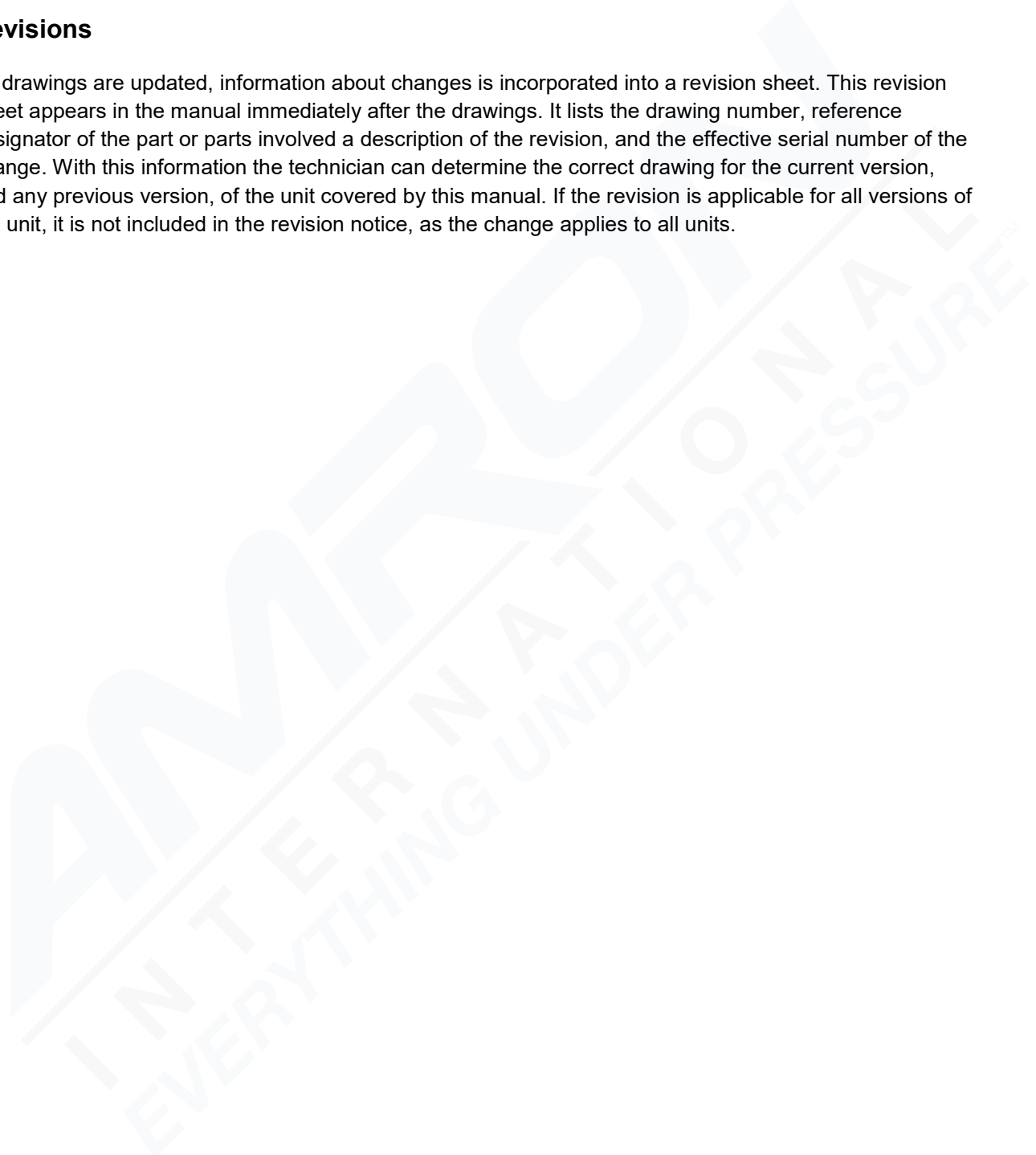

5.1 PARTS LOCATOR, TREATMENT PANEL (FRONT)

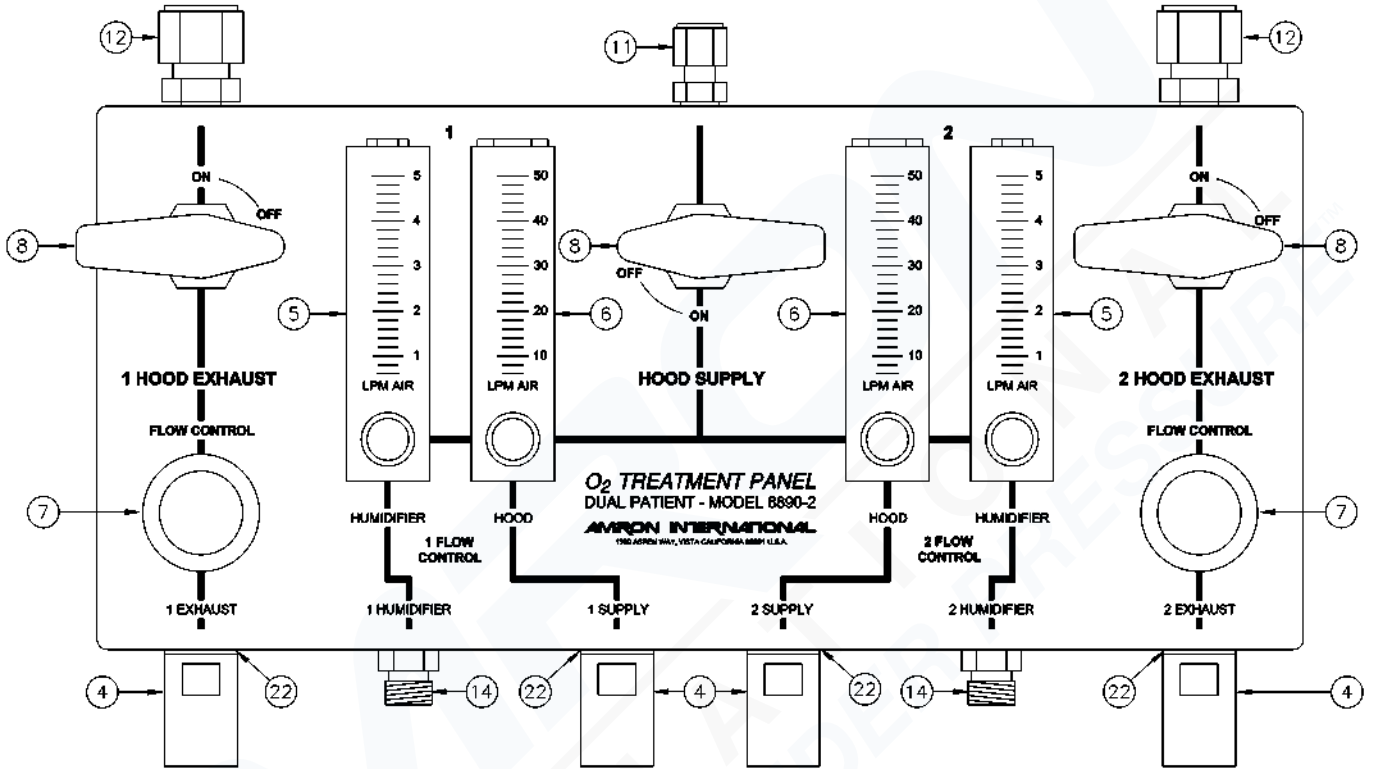

**5.2 PARTS LOCATOR, TREATMENT PANEL (BACK)**

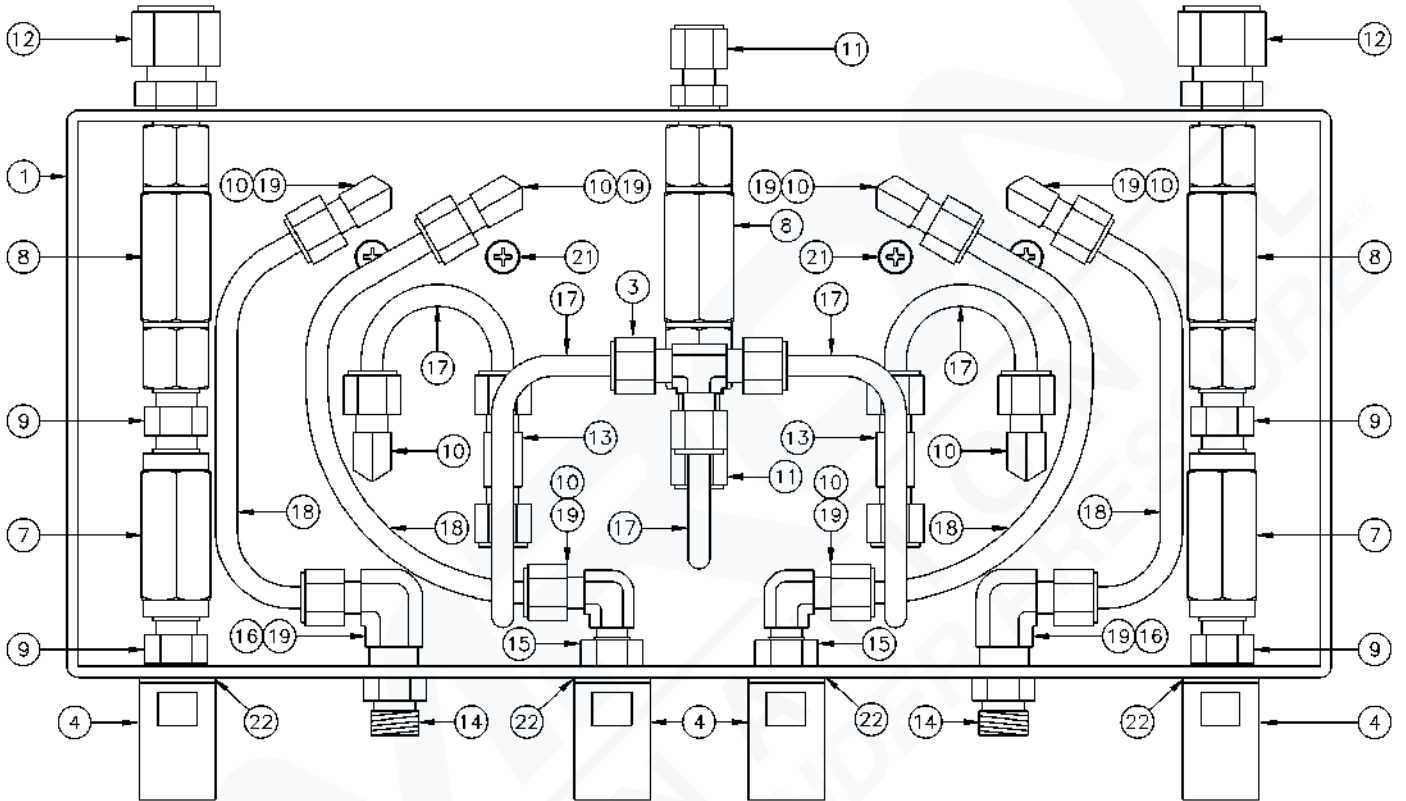

**5.3 PARTS LOCATOR, HOOD ASSEMBLY (LESS TREATMENT PANEL)**

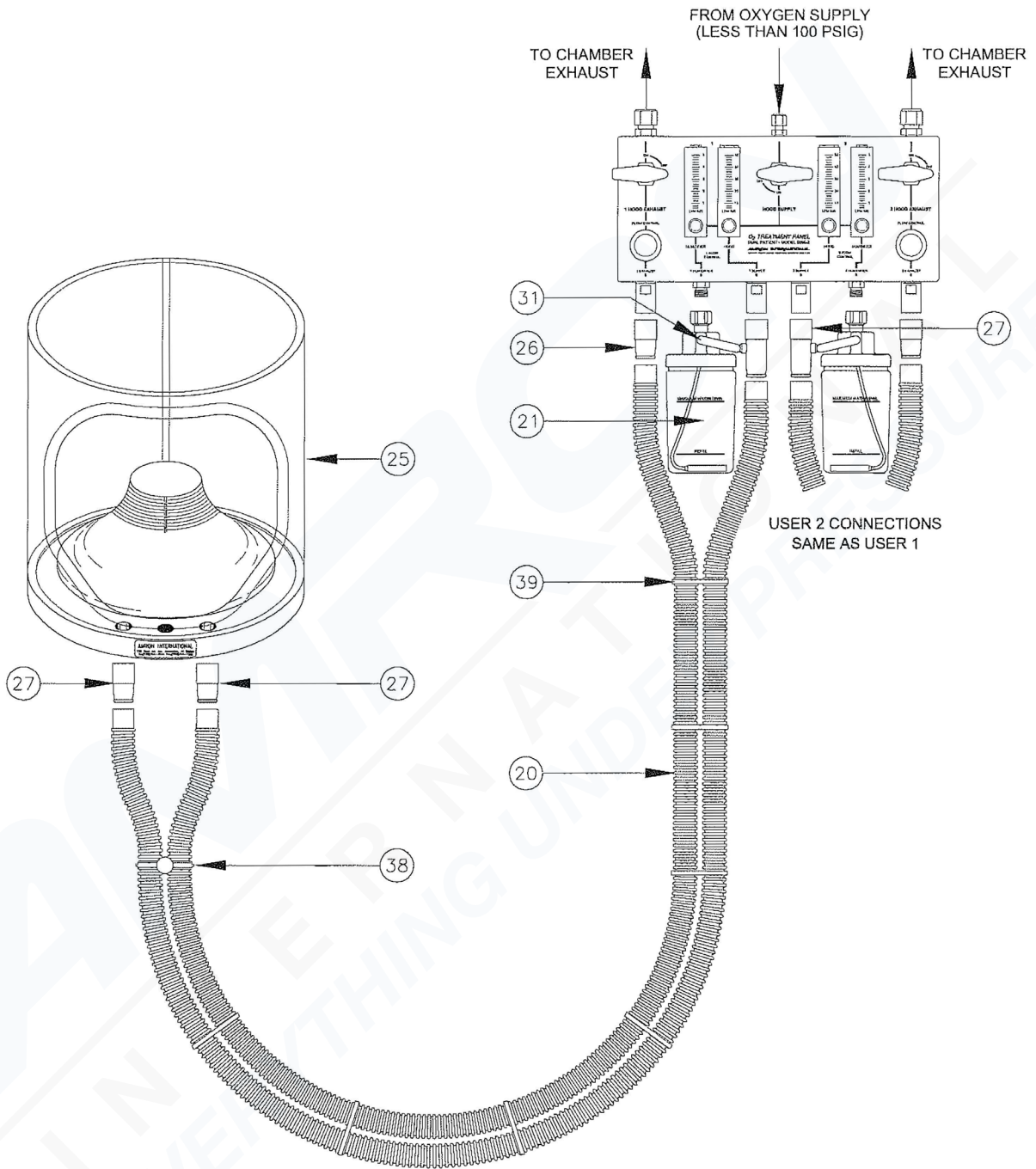

**5.5 FLOW DIAGRAM**

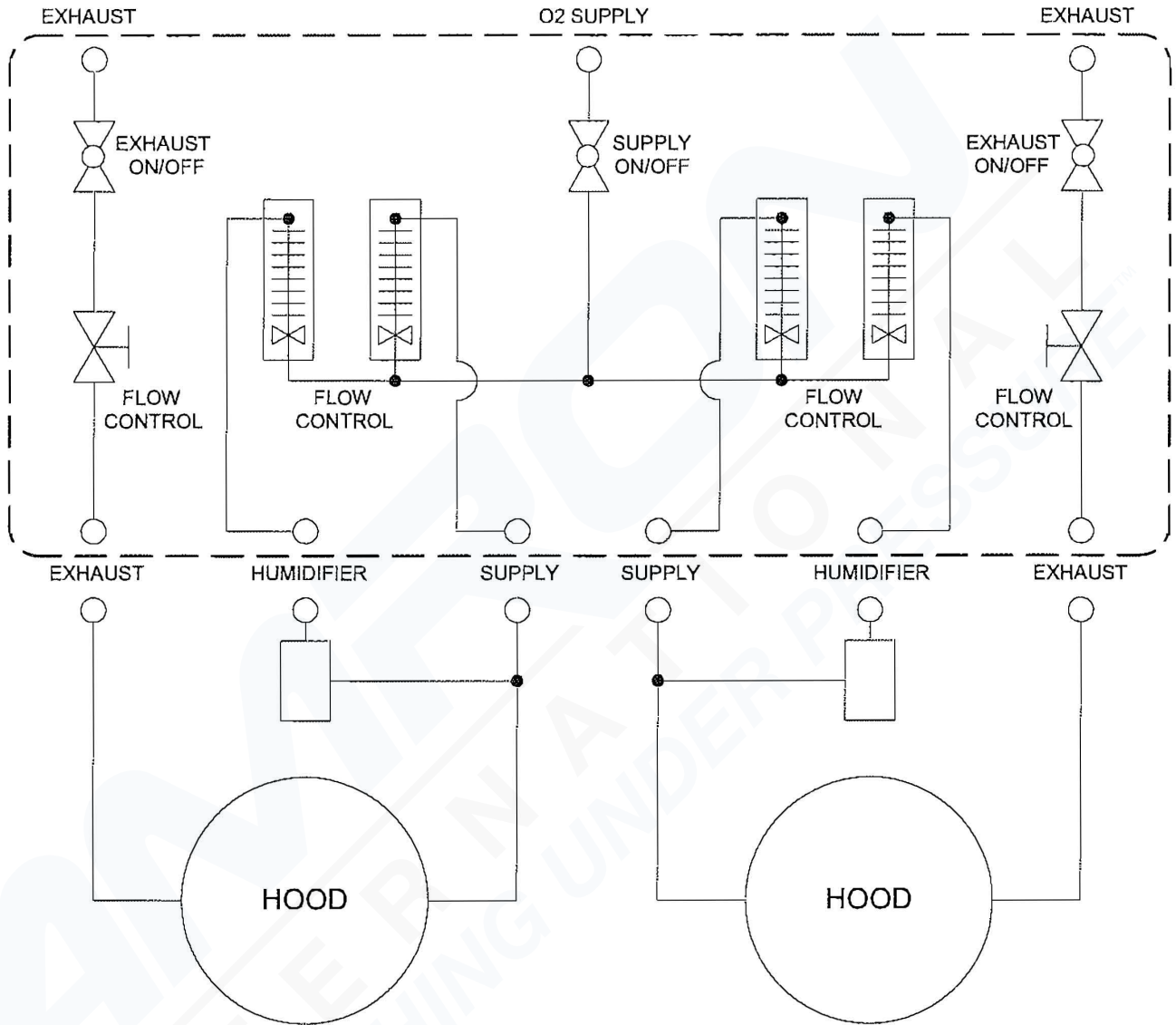

## 6 PARTS LIST GENERAL

The parts lists include both mechanical and electrical parts. The following information will be useful in interpreting data which is not self-explanatory.

### REVISIONS

The parts lists in this manual are for the current model of diver communicator as of the printing date.

To Order Replacement Parts Contact:

Amron international, Inc.  
1380 Aspen Way, Vista, California, 92081 U.S.A.  
Telephone: (760) 208-6500 Fax: (760) 599-3857  
Email: [sales@amronintl.com](mailto:sales@amronintl.com)  
Web: [www.amronintl.com](http://www.amronintl.com)

When ordering replacement parts, you should give as much information as possible to enable us to supply the correct part. This information should include the part number, description, reference designator, value, radio model number, and serial number. Failure to provide sufficient information may hinder our ability to fill your parts orders promptly and correctly.

**6.1 MODEL 8890-2 OXYGEN TREATMENT PANEL**

REFERENCE	PART NUMBER	DESCRIPTION
1	8890-011	FRONT COVER *** NOT FOR SALE ***
2	8890-012	REAR COVER *** NOT FOR SALE ***
3	CTA-4-BRAS	UNION TEE, 1/4 TUBE BRASS
4	8890-014	COUPLER, 22 MM
5	VFA-23-BV	FLOWMETER, HUMIDIFIER .6-5 LPM
6	VFA-26-BV	FLOWMETER, HOOD 6-50 LPM
7	NV3F-4N-S-OS-BRAS	VALVE NEEDLE 1/4IN FNPT INLINE
8	HB2F-4N-BRAS	BALL VALVE BRASS 1/4IN FNPT
9	FF-B-1/4	BRASS PIPE NIPPLE; SIZE: 1/4IN
10	CLMA4-2N-BRAS	ELBOW 1/8NPT X 1/4 TUBE
11	CMC4-4N-BRAS	MALE CONNECTOR 1/4 X 1/4 NPT
12	CMC8-4N-BRAS	MALE CONNECTOR 1/2 X 1/4 NPT
13	CBTM4-2N-BRAS	TEE MALE BRANCH 1/4 X 1/8 NPT
14	AF-1008	O <sub>2</sub> X 1/8 MNPT ADAPTER
15	PTR-B-1/4X1/8	PIPE THREAD REDUCER, 1/4 X 1/8
16	CLF4-2N-BRAS	FEMALE ELBOW BRASS 4-2NPT
17	CUTUS1/4	COPPER TUBING, 1/4" X .035 WALL
18	NN-4-035	NYLON TUBING, 1/4" X .035 WALL
19	TIZ.170-B-4	INSERT, BRASS .70 OD.
22	8-32X3/8SSFHP	SCREW, 8-32 X 3/8"
23	10-32X3/8SSFHP	SCREW, 10-32 X 3/8" S/S FLAT HEAD, PHILLIP
28	9/16ISW	INTERNAL STAR WASHER, S/S

**6.2 MODEL 8890-102 OXYGEN HOOD SYSTEM WITH TUBING & HUMIDIFIER**

REFERENCE	PART NUMBER	DESCRIPTION
25	8891-03	COMPLETE O2 HOOD WITH LATEX NECK SEAL
21	8890-0063	HUMIDIFIER, DISPOSABLE
27	1640	TUBING ADAPTER, 22 MM
39	528-3520	CABLE TIE
26	1642	TEE, LINE ADAPTER
38	8890-2001	TUBING HANGER
20	1680	FLEX TUBING, 22 MM X (10FT. REQUIRED)
31	0500-071	OXYGEN TUBING, PVC, 1/4 IN. ID

**6.3 RECOMMENDED SPARES**

PART NO.	DESCRIPTION	QTY.
8890-0063	HUMIDIFIER, DISPOSABLE	1
8891-03	COMPLETE HOOD W/SILICONE NECK SEAL, UNTRIMMED	1
8891-006	TORSO SEAL FOR TRACHEA PATIENTS	1
1680	FLEX TUBING, 22 MM (SOLD BY THE CASE OR FOOT)	20
1642	LINE ADAPTER TEE	1
1640	TUBING ADAPTER	1
TBD	REPAIR KIT, FOR P/N NV3FA-4N-S-OS-S316	1
KIT-HB2-SET-S316	REPAIR KIT, FOR P/N HB2F-4N-BRAS	2
0500-071	OXYGEN TUBING, PVC, 1/4 IN. ID (SOLD BY THE FOOT)	1
MCG-111-2OZ	CHRISTOLUBE GREASE, (2 OZ. TUBE)	1



**7 LIMITED WARRANTY AND SERVICE POLICY****Amron International, Inc.****LIMITED WARRANTY & SERVICE POLICY****LIMITED WARRANTY**

AMRON INTERNATIONAL, INC., (Amron) warrants that its manufactured products are free from defects in material and workmanship under normal use and service for a period of one year from date of shipment as described in Amron's literature covering this product. Oxygen Treatment Hoods and accessories are excluded and limited to 90 days. Amron's obligation under this warranty is limited to the repair or replacement, at Amron's option, of defective material. This warranty shall not cover defects which are the result of misuse, negligence, accident, repair or alterations.

**SERVICE POLICY**

For technical assistance or to request a repair, please complete one of the following:

- *Amron Communicator Repair*: <https://www.amronintl.com/communicator-repair-form>
- *Repair Request* (all other products): <https://www.amronintl.com/repair-form>
- Call (760) 208-6500, Monday – Friday, 8 a.m. to 5 p.m. PST.

Both MODEL NO. and SERIAL NO. are required fields to be entered on the *Amron Communicator Repair Request* form and can be found on the products identification label as shown below.

"Sample" Product Identification Label

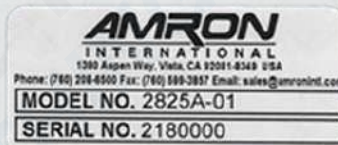

*Do not* return any product without obtaining a RMR (Return Materials Request). Detailed return instructions will be provided at the time of request.

1380 Aspen Way, Vista California 92081-8349 U.S.A  
Phone: (760) 208-6500 Fax (760) 599-3857  
Email: [sales@amronintl.com](mailto:sales@amronintl.com) Web: [www.amronintl.com](http://www.amronintl.com)