

STANLEY®

GT23 HYDRAULIC POWER UNIT



USER'S MANUAL SAFETY, OPERATION AND MAINTENANCE



© 2014 STANLEY Black & Decker, Inc.
New Britain, CT 06053
U.S.A.
69405 5/2019 Ver. 13

TABLE OF CONTENTS

SAFETY SYMBOLS.....	4
SAFETY PRECAUTIONS	5
DASH DECALS	6
HOSE TYPES	7
HOSE RECOMMENDATIONS.....	8
HTMA / EHTMA REQUIREMENTS	9
OPERATION	10
ROUTINE MAINTENANCE	14
PROGRAMMABLE CONTROLLER	15
FAULT CODES.....	16
TESTING THE HYDRAULIC CIRCUIT	17
TROUBLESHOOTING	18
SPECIFICATIONS	19
BRIGGS ENGINE ASSEMBLY	20
BRIGGS ENGINE PARTS LIST.....	21
FUEL TANK & CAP	22
FRAME PARTS	23
HOSES, FITTINGS & CLAMPS	24
MAIN WIRING HARNESS.....	25

IMPORTANT

To fill out a product warranty validation form, and for information on your warranty, visit www.stanleyinfrastructure.com and select the Company tab > Warranty.

Note: The warranty validation record must be submitted to validate the warranty.

SERVICING: This manual contains safety, operation and routine maintenance instructions. STANLEY Infrastructure recommends that servicing of hydraulic tools, other than routine maintenance, must be performed by an authorized and certified dealer. Please read the following warning.

⚠ WARNING

SERIOUS INJURY OR DEATH COULD RESULT FROM THE IMPROPER REPAIR OR SERVICE OF THIS TOOL.

REPAIRS AND / OR SERVICE TO THIS TOOL MUST ONLY BE DONE BY AN AUTHORIZED AND CERTIFIED DEALER.

For the nearest certified dealer, call STANLEY Infrastructure at (503) 659-5660 and ask for a Customer Service Representative.

SAFETY PRECAUTIONS

Tool operators and maintenance personnel must comply with the safety precautions given in this manual and on the stickers and tags attached to the equipment.

These precautions are given for your safety. Review them carefully before operating the tool and before performing general maintenance or repairs.

Supervising personnel should develop additional precautions relating to the specific work area and local safety regulations. Place the added precautions in the space provided.

In addition to this manual, read and understand safety and operating instructions in the Engine Operation Manual furnished with the power unit.

The Hydraulic Power Unit will provide safe and dependable service if operated in accordance with the instructions given in this manual. Read and understand this manual and any stickers and tags attached to the Power Unit. Failure to do so could result in personal injury or equipment damage.



- Operator must start in a work area without bystanders. The operator must be familiar with all prohibited work areas such as excessive slopes and dangerous terrain conditions.
- Establish a training program for all operators to ensure safe operation.
- Do not operate the power unit unless thoroughly trained or under the supervision of an instructor.
- Always wear safety equipment such as goggles, ear, head protection, and safety shoes at all times when operating the power unit and a hydraulic tool.
- Do not inspect or clean the power unit while it is running. Accidental engagement of the unit can cause serious injury.
- Always use hoses and fittings rated at 2500 psi/172 bar with a 4 to 1 safety factor. Be sure all hose connections are tight.
- Be sure all hoses are connected for correct flow direction to and from the tool being used.
- Do not inspect hoses and fittings for leaks by using bare hands. "Pin-hole" leaks can penetrate the skin.
- NEVER OPERATE THE POWER UNIT IN A CLOSED SPACE. Inhalation of engine exhaust can be fatal.
- Do not operate a damaged, improperly adjusted power unit.
- Never wear loose clothing that can get entangled in the working parts of the power unit.
- Keep all parts of your body away from the working parts of the power unit.
- Keep clear of hot engine exhaust.
- Do not add fuel to the power unit while the power unit is running or is still hot.
- Do not operate the power unit if gasoline odor is present.
- Do not use flammable solvents around the power unit engine.
- Do not operate the power unit within 3.3 ft/1 m of buildings, obstructions or flammable objects.
- Do not reverse tool rotation direction by changing fluid flow direction.
- Allow power unit engine to cool before storing in an enclosed space.
- Always keep critical tool markings, such as labels and warning stickers legible.
- To avoid personal injury or equipment damage, all tool repair, maintenance and service must only be performed by authorized and properly trained personnel.

DASH DECALS

STANLEY Dash Sticker 74759



Single Circuit Sticker 68595

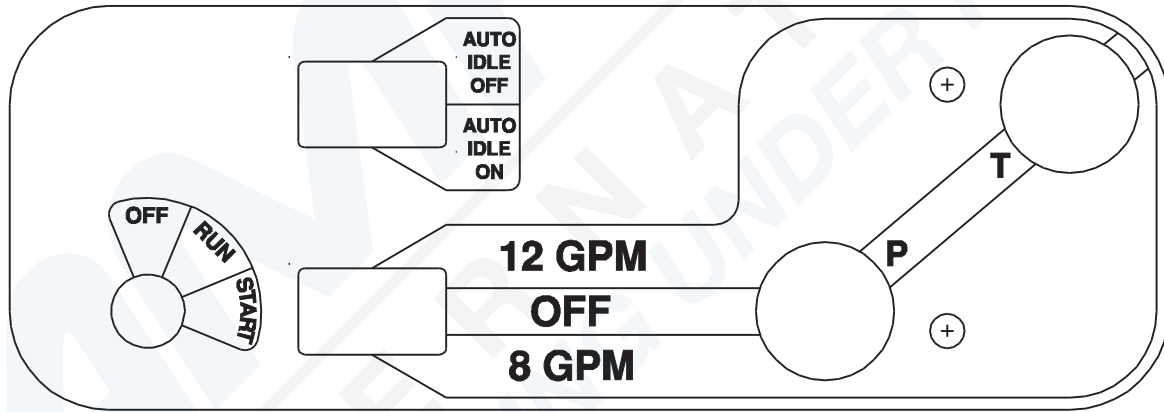

HOSE TYPES

The rated working pressure of the hydraulic hose must be equal to or higher than the relief valve setting on the hydraulic system. There are three types of hydraulic hose that meet this requirement and are authorized for use with STANLEY hydraulic tools. They are:

Certified non-conductive — constructed of thermoplastic or synthetic rubber inner tube, synthetic fiber braid reinforcement, and weather resistant thermoplastic or synthetic rubber cover. *Hose labeled **certified non-conductive** is the only hose authorized for use near electrical conductors.*

Wire-braided (conductive) — constructed of synthetic rubber inner tube, single or double wire braid reinforcement, and weather resistant synthetic rubber cover. *This hose is **conductive** and must never be used near electrical conductors.*

Fabric-braided (not certified or labeled non-conductive) — constructed of thermoplastic or synthetic rubber inner tube, synthetic fiber braid reinforcement, and weather resistant thermoplastic or synthetic rubber cover. *This hose is **not certified non-conductive** and must never be used near electrical conductors.*

HOSE SAFETY TAGS

To help ensure your safety, the following DANGER tags are attached to all hose purchased from STANLEY. DO NOT REMOVE THESE TAGS.

If the information on a tag is illegible because of wear or damage, replace the tag immediately. A new tag may be obtained from your STANLEY Distributor.

THE TAG SHOWN BELOW IS ATTACHED TO “CERTIFIED NON-CONDUCTIVE” HOSE

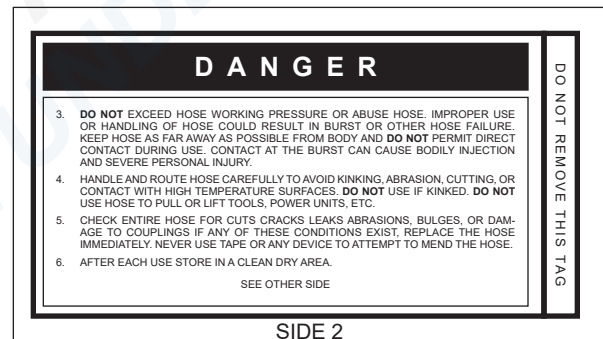
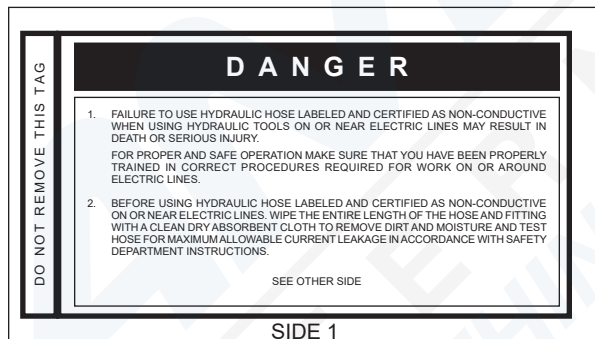

(Shown smaller than actual size)

THE TAG SHOWN BELOW IS ATTACHED TO “CONDUCTIVE” HOSE.

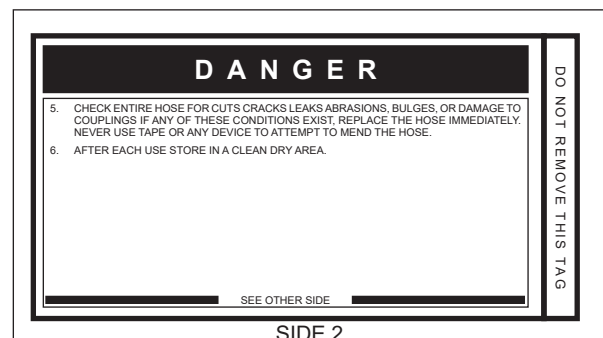
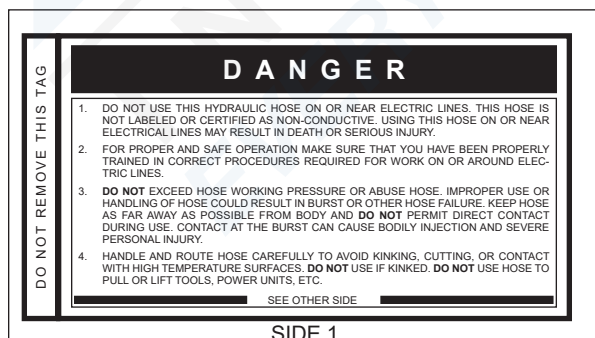

(Shown smaller than actual size)

HOSE RECOMMENDATIONS

Tool to Hydraulic Circuit Hose Recommendations

The chart to the right shows recommended minimum hose diameters for various hose lengths based on gallons per minute (GPM)/liters per minute (LPM). These recommendations are intended to keep return line pressure (back pressure) to a minimum acceptable level to ensure maximum tool performance.

This chart is intended to be used for hydraulic tool applications only based on STANLEY tool operating requirements and should not be used for any other applications.

All hydraulic hose must have at least a rated minimum working pressure equal to the maximum hydraulic system relief valve setting.

All hydraulic hose must meet or exceed specifications as set forth by SAE J517.

Oil Flow		Hose Lengths		Inside Diameter		USE (Press/Return)	Min. Working Pressure	
GPM	LPM	FEET	METERS	INCH	MM		PSI	BAR
Certified Non-Conductive Hose - Fiber Braid - for Utility Bucket Trucks								
4-9	15-34	up to 10	up to 3	3/8	10	Both	2250	155
Conductive Hose - Wire Braid or Fiber Braid - DO NOT USE NEAR ELECTRICAL CONDUCTORS								
4-6	15-23	up to 25	up to 7.5	3/8	10	Both	2500	175
4-6	15-23	26-100	7.5-30	1/2	13	Both	2500	175
5-10.5	19-40	up to 50	up to 15	1/2	13	Both	2500	175
5-10.5	19-40	51-100	15-30	5/8	16	Both	2500	175
5-10.5	19-40	100-300	30-90	5/8	16	Pressure	2500	175
10-13	38-49	up to 50	up to 15	3/4	19	Return	2500	175
10-13	38-49	51-100	15-30	5/8	16	Both	2500	175
10-13	38-49	100-200	30-60	3/4	19	Pressure	2500	175
13-16	49-60	up to 25	up to 8	1	25.4	Return	2500	175
13-16	49-60	26-100	8-30	5/8	16	Pressure	2500	175
				3/4	19	Return	2500	175
				3/4	19	Pressure	2500	175
				1	25.4	Return	2500	175

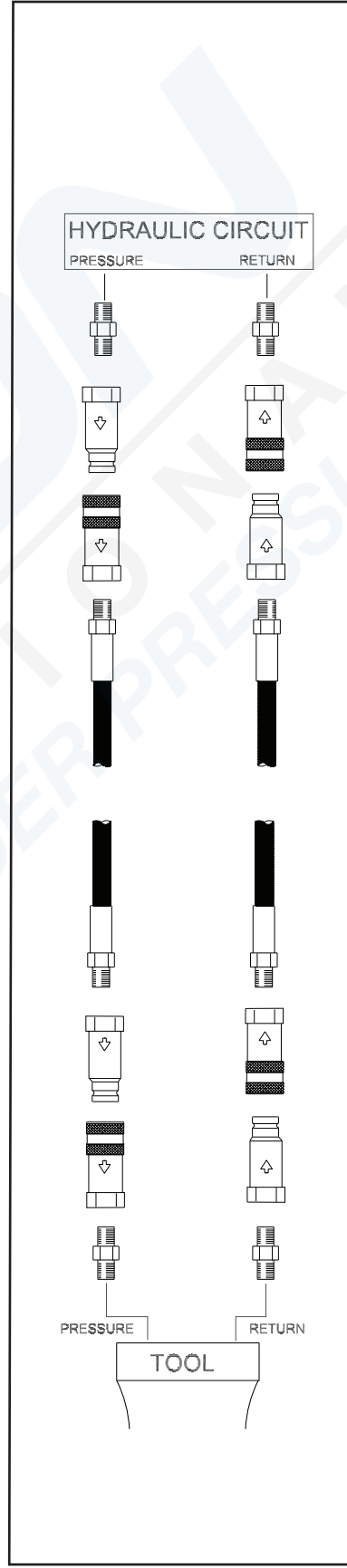

Figure 1. Typical Hose Connections





HTMA / EHTMA REQUIREMENTS

HTMA / EHTMA REQUIREMENTS

TOOL TYPE

HTMA HYDRAULIC SYSTEM REQUIREMENTS	TYPE I	TYPE II	TYPE RR	TYPE III
Flow range	4-6 GPM (15-23 LPM)	7-9 GPM (26-34 LPM)	9-10.5 GPM (34-40 LPM)	11-13 GPM (42-49 LPM)
Nominal operating pressure (At the power supply outlet)	1500 psi (103 bar)	1500 psi (103 bar)	1500 psi (103 bar)	1500 psi (103 bar)
System relief valve setting (At the power supply outlet)	2100-2250 psi (145-155 bar)	2100-2250 psi (145-155 bar)	2200-2300 psi (152-159 bar)	2100-2250 psi (145-155 bar)
Maximum back pressure (At tool end of the return hose)	250 psi (17 bar)	250 psi (17 bar)	250 psi (17 bar)	250 psi (17 bar)
Measured at a max fluid viscosity of: (At minimum operating temperature)	400 ssu* (82 centistokes)	400 ssu* (82 centistokes)	400 ssu* (82 centistokes)	400 ssu* (82 centistokes)
Temperature: Sufficient heat rejection capacity to limit maximum fluid temperature to: (At maximum expected ambient temperature)	140° F (60° C)	140° F (60° C)	140° F (60° C)	140° F (60° C)
Minimum cooling capacity at a temperature difference of between ambient and fluid temps	3 hp (2.24 kW) 40° F (22° C)	5 hp (3.73 kW) 40° F (22° C)	6 hp (5.22 kW) 40° F (22° C)	7 hp (4.47 kW) 40° F (22° C)
Note: Do not operate the tool at oil temperatures above 140° F (60° C). Operation at higher temperatures can cause operator discomfort at the tool.				
Filter minimum full-flow filtration Sized for flow of at least: (For cold temp startup and maximum dirt-holding capacity)	25 microns 30 GPM (114 LPM)	25 microns 30 GPM (114 LPM)	25 microns 30 GPM (114 LPM)	25 microns 30 GPM (114 LPM)
Hydraulic fluid, petroleum based (premium grade, anti- wear, non-conductive) Viscosity (at minimum and maximum operating temps)	100-400 ssu (20-82 centistokes)	100-400 ssu (20-82 centistokes)	100-400 ssu (20-82 centistokes)	100-400 ssu (20-82 centistokes)
Note: When choosing hydraulic fluid, the expected oil temperature extremes that will be experienced in service determine the most suitable temperature viscosity characteristics. Hydraulic fluids with a viscosity index over 140 will meet the requirements over a wide range of operating temperatures.				
*SSU = Saybolt Seconds Universal				

CLASSIFICATION

EHTMA HYDRAULIC SYSTEM REQUIREMENTS					
Flow range	3.5-4.3 GPM (13.5-16.5 LPM)	4.7-5.8 GPM (18-22 LPM)	7.1-8.7 GPM (27-33 LPM)	9.5-11.6 GPM (36-44 LPM)	11.8-14.5 GPM (45-55 LPM)
Nominal operating pressure (At the power supply outlet)	1870 psi (129 bar)	1500 psi (103 bar)	1500 psi (103 bar)	1500 psi (103 bar)	1500 psi (103 bar)
System relief valve setting (At the power supply outlet)	2495 psi (172 bar)	2000 psi (138 bar)	2000 psi (138 bar)	2000 psi (138 bar)	2000 psi (138 bar)

Note: These are general hydraulic system requirements. See tool specification page for tool specific requirements.

OPERATION

PREPARATION FOR USE

Do not operate the power unit until you have read the Engine Operating and Maintenance Instructions manual furnished with the unit.

1. ENGINE CRANKCASE OIL LEVEL

Always check the oil level before starting the engine. Make sure the oil level is at the FULL MARK on the dipstick. Do not overfill. Use detergent oil classified "For Service SE, SF, SG" as specified in the Engine Operating and Maintenance Instructions manual. See engine manual for oil viscosity grade.

2. SPARK PLUG

On power units equipped with Briggs & Stratton Engines, ONLY Champion RC12YC or equivalent can be used.

Incorrect type spark plugs can produce radio frequency interference that will corrupt and damage the controller. Failure to use the correct spark plug could result in a warranty that will not be considered.

3. ENGINE FUEL LEVEL

Check the fuel level. If low, fill with unleaded gasoline with a minimum of 85 octane.

4. HYDRAULIC FLUID

RECOMMENDED HYDRAULIC OILS

Below is a list of recommended oils by brand.

Brand	Biodegradable	Description
CITGO	No	Hydurance AW32
AMS Oil	No	HVH 32
Exxon Mobil	No	Univis HVI26*
Exxon Mobil	No	DTE 10 Excel
Shell	No	S2 V 32
Chevron	No	Rando HDZ 32
Conoco Phillips	No	Unax AW-WR-32
Clarion (CITGO)	Yes	Green Bio 32
Exxon Mobil	Yes	EAL 224H
Chevron	Yes	Clarity AW32
Terresolve	Yes	Envirologic 132
Shell	Yes	Naturelle HF-E-32

* Recommended for extreme cold temperatures

HYDRAULIC CONNECTIONS

The recommended hose length is 25 ft/8 m, with a 1/2 inch/12.7 mm inside diameter. Hoses must have a working pressure rating of at least 2500 psi/175 bar. Each hose end must have male thread ends compatible with H.T.M.A. (HYDRAULIC TOOL MANUFACTURERS ASSOCIATION) quick disconnect fittings (NPT type threads). See "HTMA / EHTMA REQUIREMENTS" on page 9.



Figure 1. Panel Control Valve

Facing the panel control valve, the bottom male quick disconnect fitting is the PRESSURE FLUID OUT fitting. The top female quick disconnect fitting is the RETURN FLUID IN fitting.

QUICK DISCONNECT COUPLERS

H.T.M.A. approved quick disconnect couplings are installed to hydraulic hoses so that the direction of oil flow is always from the male to the female quick disconnect. Quick disconnect couplings and hose fittings are selected so that additional fittings such as reducer or adapter fittings are not required.

If adapter fittings are used, they must be approved steel hydraulic fittings meeting a minimum operating pressure rating of 2500 psi/172 bar. Do not use galvanized pipe fittings or black pipe fittings.

Use thread tape or pipe joint compound when installing quick disconnect couplings to hose or tool fittings. Follow the instructions furnished with the selected thread sealant. DO NOT OVERTIGHTEN THE FITTINGS.

5. BATTERY

The supplied 12 Volt DC battery is a non-spillable, maintenance-free battery and is fully charged.

Make sure the battery cables are tight and charging circuit functions are operating properly.

OPERATION

NOTICE

Do not charge the battery with a standard automotive battery charger. This type of charger produces a charging amperage higher than 2 amps. Charging at higher than 2 amps will damage the battery.

NOTICE

If the engine runs out of gas or dies during operation and the ignition switch is left in the ON or RUN position, this could drain the battery. Make sure the ignition switch is returned to the OFF position.

OPERATION

CONTROLS

This unit is equipped with an advanced proportional engine control system. It provides a means of controlling engine speed by adjusting the fuel control lever with an actuator. The Power Unit provides one circuit, with an oil flow of 8 GPM/30 LPM up to 2000 psi/140 bar or 12 GPM/45 LPM up to 2000 psi/140 bar with a factory-programmed electronic governed engine throttle.

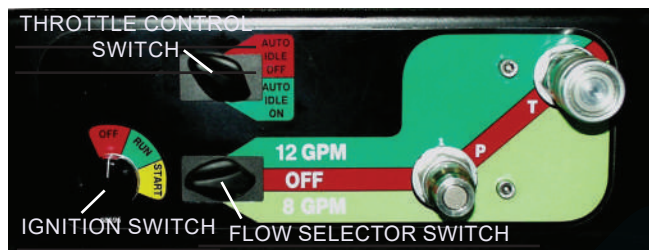

Figure 3. Panel Control Valve

One hydraulic tool can be connected to the tool circuit. The circuit is activated by turning the flow control switch to either the 8 GPM/30 LPM or 12 GPM/45 LPM setting.

THROTTLE CONTROL

The throttle control permits the operator to select one of 2 operating modes after the engine has warmed up. When starting the engine, make sure the flow selector switch is in the OFF position. The throttle control switch can be set in either the AUTO-IDLE-ON or AUTO-IDLE-OFF positions.

AUTO-ON

When the throttle control switch is in the "AUTO-ON" position, the oil flow is regulated automatically when the trigger on the tool activated. When the tool is not being used the engine will return to idle automatically, after a 10 second delay.

This setting will produce 8 GPM/30 LPM or 12 GPM/45 LPM depending on which position the operator has selected with the flow selector switch.

AUTO-OFF

When the throttle control switch is in the "AUTO-OFF" position, the engine speed is held to maintain 8 GPM/30 LPM or 12 GPM/45 LPM depending on which position the operator has selected with the flow selector switch. When a tool is not being used the engine will not return to idle until either the flow selector switch is turned to the OFF position or the throttle control switch is turned to AUTO-ON.

Note: It may be necessary to reset the Controller.

At times it may be necessary to reset the controller. This could happen if a fault occurs in the controller. For example, excessive engine speed. If a fault does occur the power unit will return to an idle and the operator will have no control of the unit. To reset the controller, simply turn off the power unit and restart it.

STARTUP

1. Before starting the engine make sure the flow selector switch is in the OFF position.

Note: The power unit will not start if the flow control switch is not in the "OFF" position.

2. Pull choke knob out and move the Throttle Control Switch to the auto-idle-off or the auto-idle-on position, whichever mode of operation the operator prefers. Ensure the flow selector switch is in the OFF position.
3. Turn the Ignition Switch to the START position. After the engine starts, release the switch.
4. Gradually push in the choke knob as the engine begins to idle smoothly.
5. Allow the engine to warm up.
6. Connect hoses and the tool as described on page 8 and 10.

FOR 8 GPM OPERATION

For 8 GPM operation, select mode of operation with the Throttle Control switch, either auto-idle-on or the auto-idle-off position. Move the flow selector switch to the 8 GPM position.

When finished operating the tool, move the flow selector switch to the OFF position.

FOR 12 GPM OPERATION

For 12 GPM operation, select mode of operation with the Throttle Control Switch, either auto-idle-on or the auto-idle-off position. Move the flow selector switch to the 12 GPM position.

When finished operating the tool, move the flow selector switch to the OFF position.

OPERATION

COLD WEATHER STARTUP

1. Use the procedures described under "STARTUP" and then follow the procedure below.
2. Hydraulic fluids are thicker in cold weather. Therefore, it is recommended that the engine be run at low idle long enough to bring the fluid temperature up to a minimum of 50°F/10°C.
3. If the tools and tool hoses are cold, it is recommended to allow hydraulic fluid to circulate through the tool hoses until warm before using the tool.

SHUTDOWN

1. Ensure the flow selector switch in the OFF position (center position).
2. Unless already at idle the power unit should return to idle. This may take a few seconds for the unit to react due to a built-in program delay.
3. Allow the engine to idle for approximately one minute and move the Ignition Switch to the OFF position.

ROUTINE MAINTENANCE

ENGINE MAINTENANCE

Follow the maintenance schedule and general maintenance instructions in the engine maintenance and operation manual furnished with the power unit.

HYDRAULIC SYSTEM MAINTENANCE

- Check hydraulic fluid level daily. Add fluid per specifications in this manual. See "RECOMMENDED HYDRAULIC OILS" on page 10.
 - Remove condensed moisture from the hydraulic fluid by pumping the hydraulic fluid into a 5 gal/20 l container through the pressure hose. Make sure the engine is at idle when performing this procedure. When the hydraulic reservoir is empty turn the engine off immediately.
 - Allow the fluid to sit long enough for the water to settle to the bottom of the container. Slowly pour the fluid back into the hydraulic tank, avoiding the water at the bottom of the container.
 - Each day, check hydraulic lines and fittings for leaks, kinks, etc. Do not use your hand to perform this check.
 - Change the hydraulic filter element every 200 hours of operation. Change more often if cold, moist or dusty conditions exist.
 - Check oil cooler for debris. Remove debris with air pressure.
- fuel from gumming. Run engine for a short period to circulate the additive.
- Replace crankcase oil with new oil.
 - Remove spark plugs and pour approximately 1 ounce (30 ml) of engine oil into each cylinder. Replace spark plugs and crank the engine slowly to distribute the oil.
 - Check hydraulic reservoir for water. If water is found, change the oil and circulate it through the tool hose and tool.
 - Disconnect tool hoses.

SPARK PLUGS

On power units equipped with Briggs & Stratton Engines, ONLY Champion RC12YC or equivalent can be used.

Incorrect type spark plugs can produce radio frequency interference that will corrupt and damage the controller. Failure to use the correct spark plug could result in a warranty that will not be considered.

STORAGE

- Clean the unit thoroughly before storage. Do not use water pressure.
- Always store the unit in a clean and dry facility.
- If the unit will be stored for a prolonged period (over 30 days), add a fuel additive to the fuel tank to prevent the

PROGRAMMABLE CONTROLLER

The STANLEY programmable controller is an electronic engine governor that controls and limits engine speed by adjusting the fuel control lever with a proportional actuator.

The controller is factory programmable and has no manual adjustments.

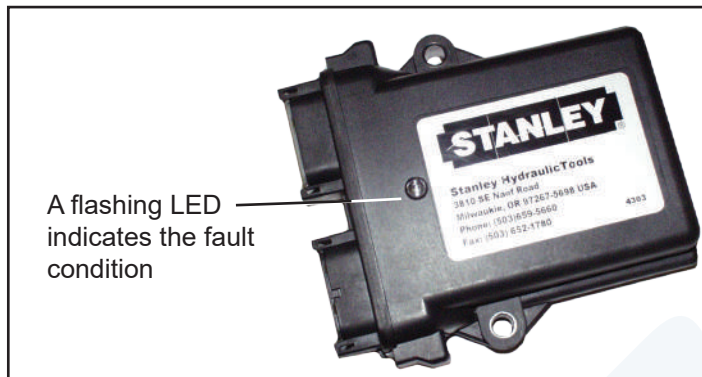

CALIBRATION

Calibration and programming must be done by the factory.

TROUBLESHOOTING GUIDELINES

Please follow the checklist below to troubleshoot your STANLEY controller.

1. Check battery voltage for stability and correct value. The LED will turn on for one second when the controller is first powered up.
2. Check the actuator linkage for binding and backlash.

CHECKING PERFORMANCE CONTROL (ELECTRONIC GOVERNOR-STATIC CHECK)

To determine whether a governor problem is being caused by the actuator or the control module, perform the following static check, exactly in order shown.

A pair of jumper wires and a known good 12-volt battery is required.

1. Disconnect red wires from the control module to actuator.
2. Attach jumper wires from battery to the RED wires to actuator.
3. Actuator should move throttle lever to wide open

position.

- If actuator does not move it is defective. (Replace).
- If actuator moves throttle to wide-open position, the module is defective. (Replace).

Note: Before replacing the actuator verify signal inputs to module (see STANLEY Electrical Trouble shooting guide ", TechHELP # 032807. A copy of the TechHELP can be obtained from the STANLEY web site at stanleyinfrastructure.com or contact a Customer Service Representative at (503) 659-5660.

FAULT CODES

The STANLEY controller is capable of identifying certain fault conditions and alerting the user to them. A flashing LED indicates the fault conditions. The current fault code list is shown on the following page. Please note the following:

1. When power is first applied to the controller, the LED will flash just once for one second to indicate that the LED is working.
2. If there are multiple faults, the LED will flash them all in sequence. Count the flash codes to determine the fault conditions or connect the Calibration Tool to observe the fault conditions. (Use the "Display Faults" option under the Monitor Menu.)
3. If there are no faults, the LED will flash once at reset and from then on indicate the detection of engine speed. A continuous ON LED indicates that a valid engine speed is being sensed.
4. The controller will attempt to shut down for some faults and will not permit starting after reset with faults 1, 5 and 8.

FAULT CODES

Flash Code	Fault	Engine Shutdown	Corrective Action
1	Unit not calibrated	Yes	Have engine serviced by an Authorized STANLEY Dealer.
2	Engine speed excessive	Yes	Have engine serviced by an Authorized STANLEY Dealer.
3	Engine speed unusually low	Yes	Have engine serviced by an Authorized STANLEY Dealer.
4	Engine shutdown due to engine protection input	Yes	Have engine serviced by an Authorized STANLEY Dealer.
5	Factory settings lost	Yes	Have engine serviced by an Authorized STANLEY Dealer.
6	External pot out-of-range	No	Have engine serviced by an Authorized STANLEY Dealer.
7	Accelerator position / idle switch conflict	No	Have engine serviced by an Authorized STANLEY Dealer.
8	Controller unit failed	Yes	Have engine serviced by an Authorized STANLEY Dealer.
9	Limiting excessive actuator current	No	Have engine serviced by an Authorized STANLEY Dealer.
10	Engine speed input signal missing	No	(Active only in auto crank mode) Check speed sensor wiring. Check starter motor.
11	Auto crank unable to start engine	No	Check fuel
12	Auxiliary output is shorted	No	Check the lamp or relay hooked to the output. If fault is still present have engine service by an authorized STANLEY Dealer.
13	Auxiliary output #2 is shorted	No	Check the lamp or relay hooked to the output. If fault is still present have engine service by an authorized STANLEY Dealer.
14	Actuator disconnected or open circuit	No	Check actuator wiring and actuator resistance. Resistance should be less than 10 Ohms.

TESTING THE HYDRAULIC CIRCUIT

GENERAL

Tests and adjustments should be performed periodically to ensure the power unit is operating at maximum efficiency. STANLEY Circuit Tester is recommended. This tester can be used to isolate problems in both the engine and hydraulic system prior to any power unit disassembly.

TESTING THE HYDRAULIC CIRCUIT

The following tests can be performed to ensure that the hydraulic pump is supplying the correct flow and pressure and that the system relief valve is operating properly.

During these tests, make sure the engine is warm and operating smoothly. If test results are not as specified, refer to the troubleshooting table in this section for possible causes.

TESTING THE 8 GPM HTMA TYPE II CIRCUIT OR THE 12 GPM TYPE III CIRCUIT

To test the circuit, proceed as follows:

1. Set the flow selector switch to the OFF (center) position.
2. Set the throttle control switch to AUTO-OFF position.
3. Connect the STANLEY Circuit Tester across two hose ends (where the tool would normally be connected).
4. Fully open the tester restrictor valve (counterclockwise).
5. Start the engine and allow it to run until warm.
6. Switch the flow selector switch to 8 or 12 GPM depending on which flow you are testing.
7. With the engine at the programmed speed, the test flow gauge should read 7-9 GPM/26.5-34 LPM or 11-13 GPM/41.6-49 LPM.
8. Slowly turn the restrictor valve clockwise while watching the pressure gauge. The flow rate should stay at 7-9 GPM/26.5-34 LPM or 11-13 GPM/41.6-49 LPM as the pressure gauge reaches 2100-2200 psi/148-155 bar.
9. At 2100-2200 psi/148-155 bar, the relief valve should begin to open. The pressure at which the relief valve just begins to open is commonly referred to as the

"cracking pressure". At the "cracking pressure," the flow rate should start to drop because the relief valve is allowing fluid to bypass to the hydraulic reservoir. The "cracking pressure" is preset at the factory and if it is not within the above range, the relief valve must be reset as follows:

- a. The relief valve is located on the right side of the unit just behind the dash panel. It protrudes out from the manifold assembly. Use an open end or box end wrench to loosen the nut on the relief valve.
- b. Use an Allen wrench to adjust the relief valve. Turn clockwise to raise the pressure and counterclockwise to reduce the pressure.
- c. Tighten the nut and test again.

TROUBLESHOOTING

PROBLEM	CAUSE	SOLUTION
Engine will not start.	Flow selector switch not in the OFF position.	Make sure the flow selector switch is in the OFF position when starting.
	Battery not connected.	Attach battery cables, check wires.
	Weak battery.	Test battery, charge or replace.
	No fuel.	Add Fuel.
	Fuel filter plugged.	Replace fuel filter.
	Defective spark plugs.	Remove plugs, check gap, clean or replace.
Fluid blowing out of fluid reservoir vent.	Hydraulic tank overfilled.	Correct the fluid level.
	Pump suction leak.	Check suction connections. Tighten if necessary.
Hydraulic tool won't operate	Flow selector switch not switched ON.	Check that the flow selector switch is set to 8 or 12 GPM.
	Incorrect hose connection to tool.	Make sure the tool hose circuit goes from left (pressure) fitting to tool and back to the right fitting (return). Fluid always flows from the male to female fittings.
	Quick disconnect fittings defective.	Detach from hose, connect set together and check for free flow.
	Hydraulic fluid level low.	Check for correct fluid level. Fill using the recommended fluid.
	Pump coupling defective.	With the engine not running. Check the coupling between the pump and engine that is engaged and is not damaged. Caution: Keep hands clear of rotating objects.
	Relief valve stuck open.	Adjust or replace valve.
	Suction hose kinked.	Make sure suction hose from fluid reservoir to pump inlet has a smooth curve.
	Solenoid not working.	Check solenoid operation and electrical connections.
	Tool is defective.	Refer to tool manual.

SPECIFICATIONS

Engine:23 hp Briggs
 Capacity.....One 8 GPM/30 LPM Circuit or One 12 GPM/45 LPM Circuit
 Length:..... 36 in. / 91.4 cm
 Width: 23 in. / 58.4 cm
 Height: 29.5 in. / 74.9cm
 Weight (Wet): Single Circuit Briggs330 lbs / 149.6 kg
 Fuel Tank Capacity: 5.5 gal. / 20.8 ltr
 Estimated Gas Consumption Per Hour 1.3 gal / 4 ltr
 Hydraulic Reservoir Capacity: 3 gal. / 11 ltr
 Relief Valve "crack" setting 2100 psi / 145 bar
 Full relief setting 2500 psi / 172 bar



HTMA Category... "D" (30 LPM @ 138 bar) or "E" (45 LPM @ 138 bar)

Nominal Pressure 1500 psi/103 bar
 Max Pressure 2000 psi/138 bar

POWER UNITS, TRACHORSE & GAS/FUEL DRIVEN EQUIPMENT: A1. Federal Emission Component Compliance 40CFR part 1060.120. STANLEY warrants all fuel system emission components for 2 years from the date of original purchase provided there has been no abuse, neglect, modifications or improper maintenance. Components covered: The emission-related warranty covers all components whose failure would increase the evaporative emissions. Your emission-related warranty does not cover components whose failure would not increase evaporative emissions. Coverage under this warranty extends only to the following parts; fuel tank, fuel cap, fuel hose and vapor hose from the fuel tank to the engine and any connectors that are apart of the fuel system. The equipment is designed, built, and equipped so it conforms at the time of sale to the ultimate purchaser and each subsequent purchaser and is in compliance with 40 C.F.R. 1060.120 standards. The equipment is free from defects in materials and workmanship that may keep it from meeting these requirements.

BRIGGS ENGINE ASSEMBLY

Note: Item # 15 Filter Assembly has a "Filter Service Kit" available P/N-43592.

The kit consists of: Filter Element, Lid Gasket and Bowl O-Ring.

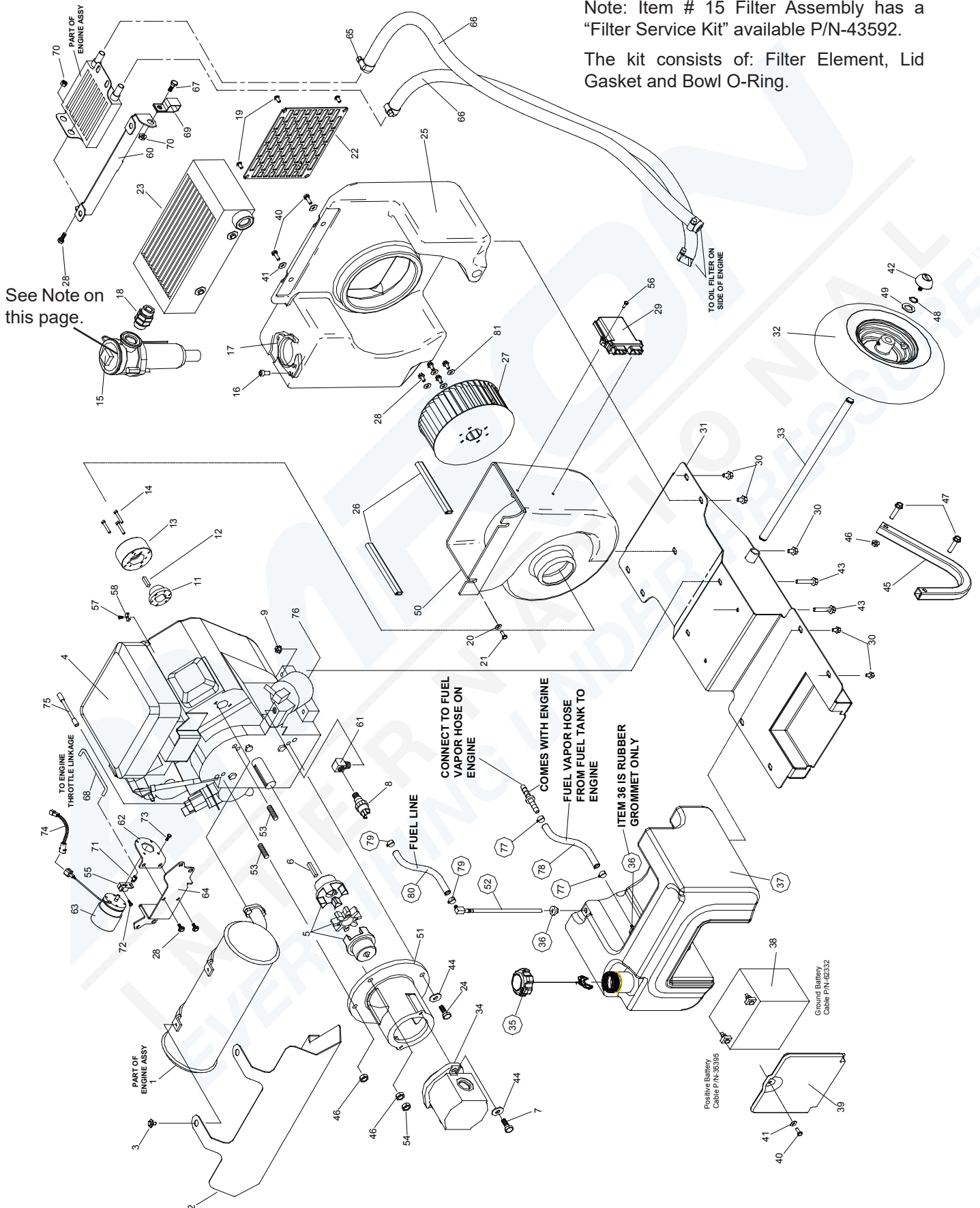

BRIGGS ENGINE PARTS LIST

ITEM	P/N	QTY	DESCRIPTION
1	68674	1	MUFFLER (PART OF ITEM 4 SEE BRIGGS & STRATTON DEALER)
2	66214	1	HEAT SHIELD
3	36152	2	SCREW HEX WASHER
4	68674	1	BRIGGS ENGINE
5	56656	1	COUPLING
6	7819	1	SQUARE KEY
7	78600	2	CAPSCREW 3/8-16 X 1-1/4
8	31765	1	PRESSURE SWITCH
9	12787	4	FLANGE NUT
11	59076	1	BUSHING
12	20990	1	KEY
13	65108	1	BLOWER HUB
14	00111	3	CAPSCREW
15	40080	1	FILTER ASSY
16	43687	2	CAPSCREW
17	64937	1	GRIP PLATE
18	51292	1	STD THREAD UNION
19	17821	4	BUTTON HEAD HS
20	26831	2	WASHER 1/4 IN. ID
21	01213	2	CAPSCREW 1/4 -20 UNC
22	59080	1	FRONT GRILLE
23	59091	1	COOLER
24	07860	2	CAPSCREW 3/8
25	59077	1	HYDRAULIC TANK
26	62296	2	WEATHER STRIP
27	65107	1	BLOWER WHEEL
28	80986	4	HEX FLANGE BOLT 1/4 -20
29	69407	1	ENGINE CONTROLLER
30	40433	9	HEX FLANGE BOLT
31	58897	1	FRAME BASE WELDMENT
32	58918	2	WHEEL & TIRE
33	58917	1	AXLE
34	81743	1	PUMP SINGLE
35	71794	1	FUEL CAP
36	60920	1	GROMMET
37	73050	1	FUEL TANK
38	04303	1	BATTERY
39	60921	1	BATTERY COVER
40	15476	3	CAPSCREW 1/4-20 X 3/4
41	60945	3	WASHER
42	21714	2	HANDLE BUMPER
43	58942	4	HEX FLANGE BOLT
44	01459	4	LOCKWASHER 3/8
45	58975	2	FOOT
46	18893	4	FLANGE NUT 3/8-16
47	58976	4	HEX FLANGE BOLT 3/8-16
48	31240	2	RETAINING RING
49	21318	2	WASHER 3/4
50	59083	1	BLOWER HOUSING

ITEM	P/N	QTY	DESCRIPTION
51	56655	1	PUMP MOUNT
52	60919	1	FUEL ELBOW
53	62385	2	STUD
54	371503	1	NUT
55	69374	1	THROTTLE LEVER
56	62292	2	HEX WASHER HEAD SCREWS
57	64991	1	SCREW
58	56709	1	CABLE CLAMP
59	-----	--	NO ITEM
60	66215	1	COOLER MOUNT
61	69387	1	90° 1/8 NPT STREET EL.
62	68675	1	ANGLE BRACKET WELDMENT
63	68560	1	ROTARY ACTUATOR
64	68676	1	ACTUATOR BRACKET
65	69384	4	HOSE CLAMP
66	69383	2	HOSE
67	59075	1	HEX FLANGE SCREW
68	69288	1	THROTTLE LINK
69	60774	1	CLAMP
70	59095	3	HEX FLANGE NUT
71	62181	1	LINK RETAINER
72	69282	1	HEX SOCKET HEAD CAPSCREW 8-32
73	69281	4	HEX SOCKET HEAD CAPSCREW 6-32
74	69401	1	WIRE ASSEMBLE
75	65042	1	RECTIFIER WIRE
76	01212	1	PIPE PLUG
77	72451	3	SPRING HOSE CLAMP
78	72571	1	FUEL VAPOR HOSE
79	72317	2	SPRING HOSE CLAMP
80	62289	1	FUEL HOSE
81	80984	4	WASHER
AC1	40408	1	FILTER ELEMENT (PART OF ITEM # 15)
AC2	43592	1	FILTER SERVICE KIT (INCLUDES FILTER AND SEALS)

FUEL TANK & CAP

Note: When ordering a fuel tank (item 37) or fuel tank cap (item 35) **DO NOT MIX OLD STYLE TANK AND CAP WITH NEW STYLE TANK AND CAP.**

If you have a power unit and it was purchased prior to 2011 and need to replace the fuel tank or fuel tank cap, you must purchase the same tank and cap that came with your unit.

For example if you have a power unit prior to 2011 do not purchase a new style fuel tank, your engine will not be equipped with a fuel vapor fitting.

The old style fuel cap is a vented cap, while the new style fuel cap is not a vented cap and venting is achieved thru the vapor line.

The old style fuel tank has only one fuel line coming from the tank to the engine. The new style fuel tank has two lines coming from the fuel tank to the engine, one is the fuel line and the other is a fuel vapor line.

OLD STYLE FUEL TANK & CAP (PRIOR TO 2011)

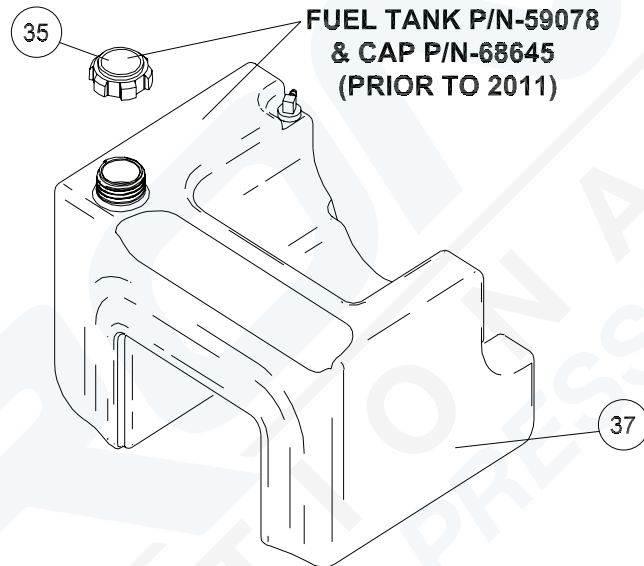

NEW STYLE FUEL TANK & CAP (2011 & FORWARD)

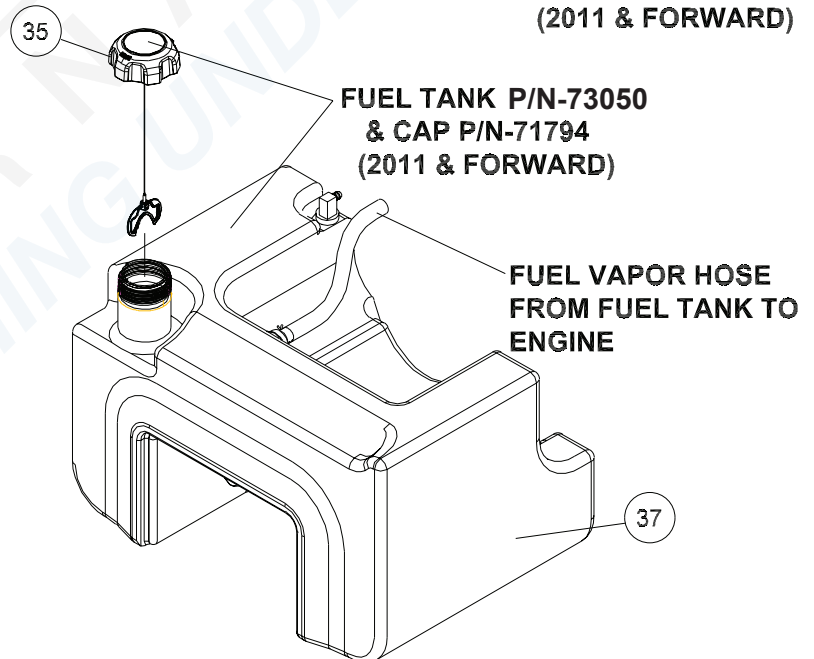

FRAME PARTS

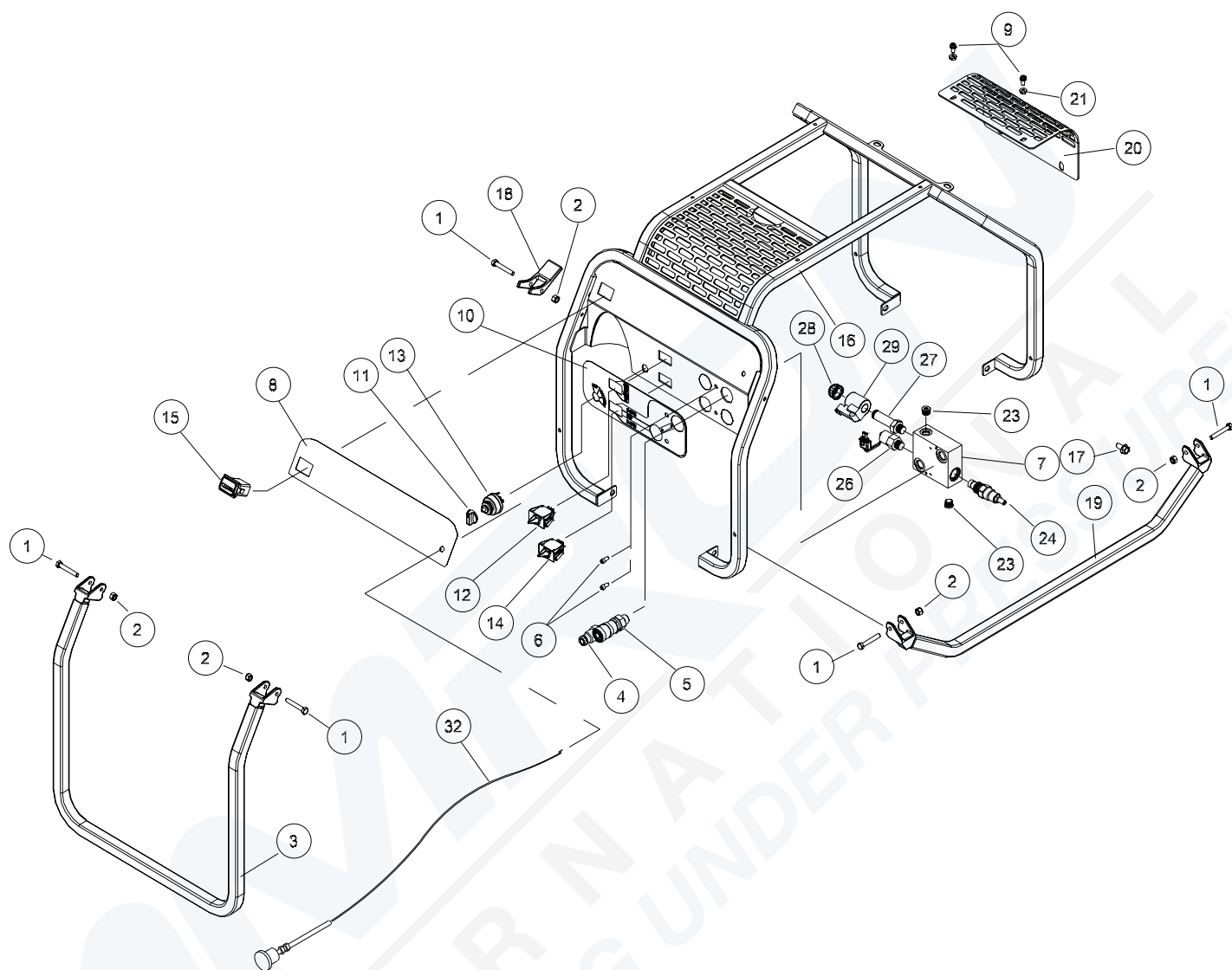

ITEM	P/N	QTY	DESCRIPTION
1	370502	7	CAPSCREW 5/16 IN. -18 UNC
2	03906	7	NYLOCK NUT 5/16 IN. -18 UNC
3	62267	1	HANDLE REAR LIFT
4	58857	1	COUPLER MALE 3/8 IN. -8 SAE
5	58856	1	COUPLER FEMALE 3/8 IN. -8 SAE
6	60962	2	CAPSCREW 1/4 IN. -20
7	59130	1	MANIFOLD ASSY SINGLE CIRCUIT (INCLUDES ITEMS 23 THRU 29)
8	74759	1	DASH DECAL
9	59075	2	HEX FLANGE BOLT 1/4-20 X 5/8
10	68595	1	DECAL SINGLE CIRCUIT
11	67899	1	KNOB (PART OF ITEM 13)
12	60955	1	2-WAY SWITCH
13	67899	1	ROTARY SWITCH
14	60956	1	3-WAY SWITCH
15	60946	1	HOUR METER
16	62269	1	FRAME WELDMENT

ITEM	P/N	QTY	DESCRIPTION
17	23530	2	HEX FLANGE BOLT 3/8 IN. -16
18	58916	1	HANDLE LOCK
19	62268	2	LIFT HANDLE
20	59079	1	COOLER GUARD
21	59095	2	FLANGE NUT 1/4 IN. -20
23	08104	2	HOLLOW HEX PLUG 6 SAE
24	59131	1	RELIEF VALVE
26	59128	1	PRESSURE SWITCH ASSY
27	60959	1	DIRECTIONAL VALVE
28	-----	1	CAP (INCLUDED WITH ITEM 27)
29	60958	1	COIL
32	62298	1	CHOKE CABLE ASSY
33	35395	1	WIRE ASSY 24 INCH (NOT SHOWN)
34	62332	1	WIRE ASSY 22 INCH (NOT SHOWN)
35	64942	1	12V RECEPTACLE (NOT SHOWN)
36	65147	1	WIRE HARNESS (NOT SHOWN)

HOSES, FITTINGS & CLAMPS

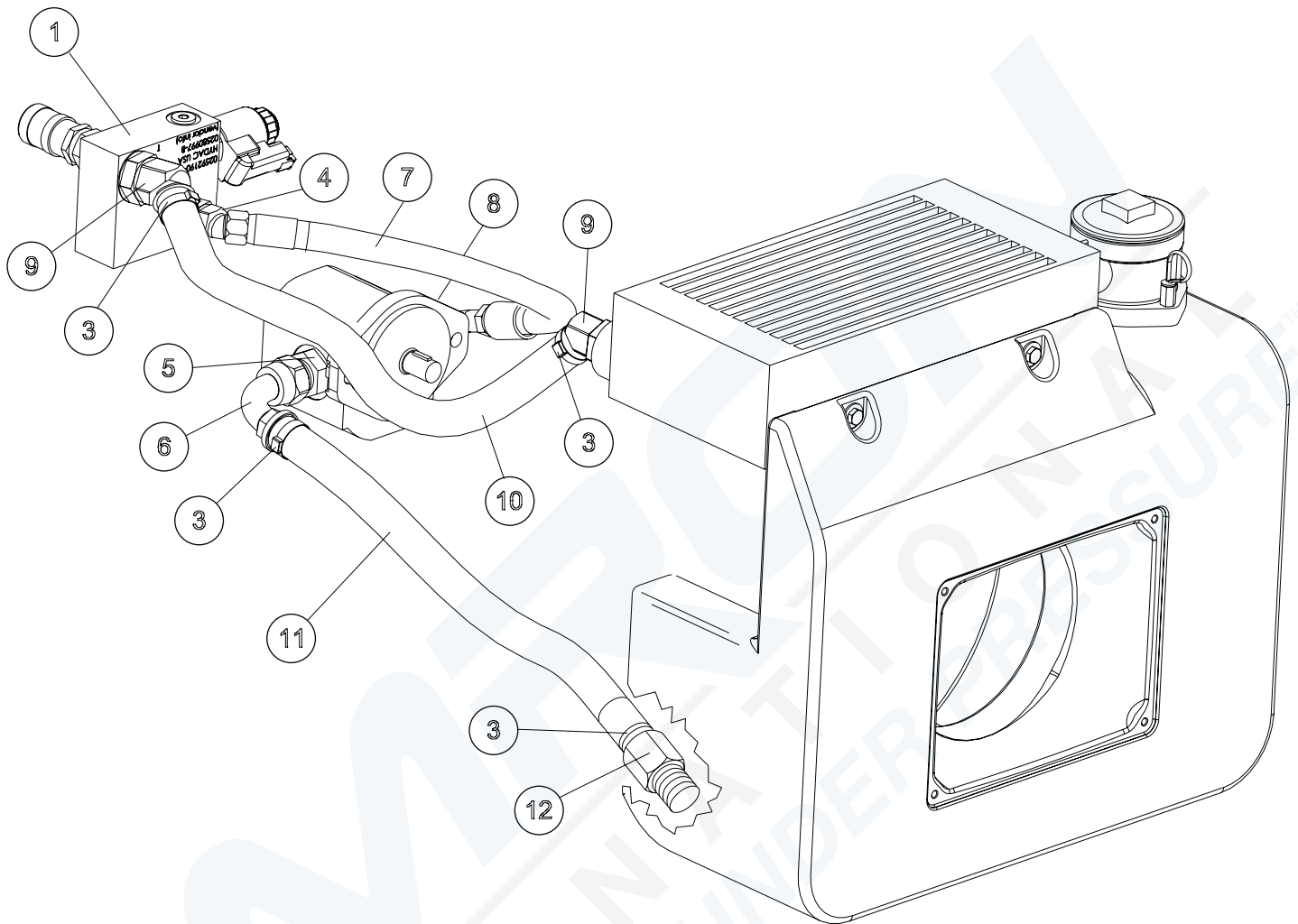

ITEM	P/N	QTY	DESCRIPTION
1	59130	1	MANIFOLD ASSY SINGLE CIRCUIT
3	62199	4	HOSE CLAMP
4	350000	1	ELBOW 45° STRAIGHT THREAD
5	2773	1	ADAPTER
6	58569	1	ELBOW 90°
7	58943	1	HOSE
8	350104	1	CONNECTOR STRAIGHT THREAD
9	40364	2	ELBOW 45°
10	59088	1	HOSE
11	59089	1	HOSE
12	59105	1	HOSE BARB 3/4 IN. HOSE X 3/4 IN. PIPE

MAIN WIRING HARNESS

Wire Harness P/N-65147

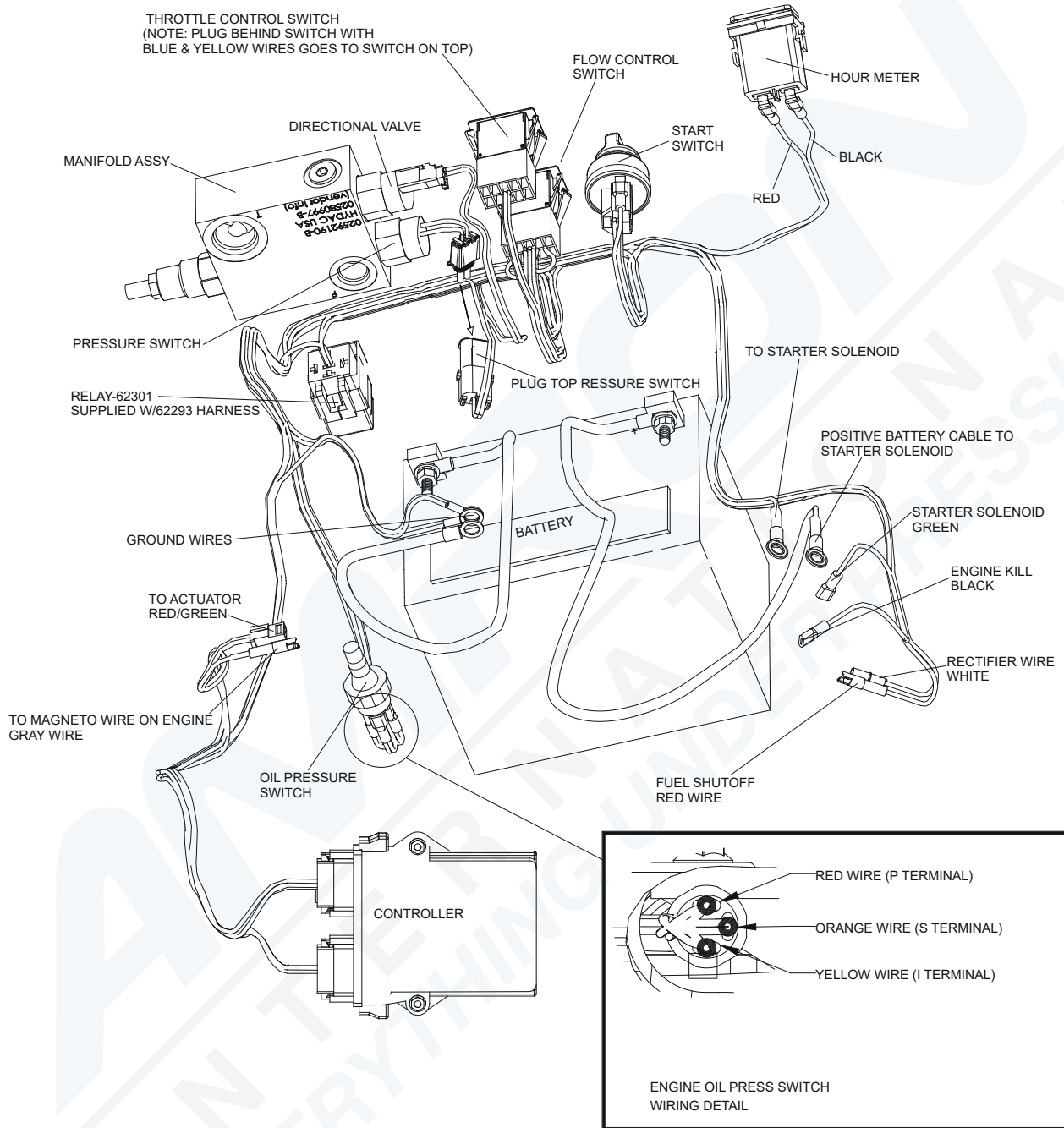

STANLEY®

STANLEY Infrastructure
6430 SE Lake Road
Portland, Oregon 97222 USA
(503) 659-5660 / Fax (503) 652-1780
www.stanleyinfrastructure.com