

User Manual
For
Amron International, Inc.

**Model 8330i & 8330iC-01
3-Diver Air Control Systems**

S/N: _____



1380 Aspen Way, Vista California 92081-8349

United States of America

Phone: (760) 208-6500

Fax (760) 599-3857

Email: sales@amronintl.com

Web: www.amronintl.com

This manual and the information contained herein are provided for use as an operation and maintenance guide. No license or rights to manufacture, reproduce, or sell either the manual or articles described herein are given. Amron International, Inc. reserves the right to change specifications without notice.

Copyright© 2018 Amron International, Inc.

TABLE OF CONTENTS

1. INTRODUCTION AND SPECIFICATIONS	1
1.1 Introduction.....	1
1.2 Specifications Air Control	2
1.3 Specifications Depth Monitoring (Pneumo).....	3
1.4 Specifications Communications (8330iC-01 Model Only).....	3
1.5 Specifications Enclosure	4
2. OPTIONS AND ACCESSORIES.....	5
2.1 Model /28A Wireless Tender Option	5
2.2 Model 2821-28 Walk-and-Push-to-Talk (2-Wire Operation)	5
2.3 Model 2822-28 Remote Walk-and-Talk (4-Wire Operation)	5
2.4 Model 2460-28 Headset.....	5
2.5 Model 2829-11 Wireless Kit with Case	5
2.6 Model 2405-28 Hand Held Microphone	5
3. SAFETY AND REGULATIONS.....	6
3.1 Diving Safety and Regulations	6
3.2 Personnel Requirements.....	7
3.3 Air Supply Requirements	7
3.4 Calibration, Service and Inspection	8
4. CONTROLS & CONNECTIONS	9
4.1 Air Control	9
4.3 Communications (8330iC-01 Model Only)	10
5. PRE-DIVE PROCEDURES	14
5.1 Pre-Dive Set-Up	14
5.2 Pre-Dive Check Out	14
5.3 Pre-Dive Pneumo Test.....	15
5.4 Pre-Dive Testing Communications (8330iC-01 Model Only)	15
5.5 Connecting Diver Umbilical	16
5.6 Low Pressure Supply	16
6. OPERATING PROCEDURES.....	17
6.1 Low Pressure Breathing Air (Primary Supply)	17
6.2 High Pressure Breathing Air (Primary Supply).....	17
6.3 Pre-Operation Checklist	17
6.4 Pneumo Readings.....	18
6.5 Diver Communications (8330iC-01 Models Only).....	19
6.6 2-Wire Operation (Refer to 6.9).....	19
6.7 4-Wire Operation (Refer to 6.10).....	20
6.8 Setting the Volume Controls	20
6.9 Drawing, 2-Wire Connections	22

7. MAINTENANCE.....	24
7.1 Review of Scheduled Maintenance.....	24
7.2 Air Control Scheduled Maintenance	24
7.3 Communicator Maintenance	25
8. TROUBLESHOOTING.....	27
8.1 General Information	27
8.2 Air Control	28
8.3 Depth Monitoring.....	30
8.4 Communicator Check Procedures	30
8.5 Communicator Troubleshooting.....	32
9. REFERENCE MATERIAL.....	36
9.1 Diving Log, U.S. Navy (Chart).....	36
9.2 Repetitive Dive Worksheet.....	37
9.3 No Decompression Limits	38
9.4 Gauge Pressure for Depth of Seawater & Fresh water	39
9.5 Equivalent Depths of Seawater & Freshwater	40
10. DRAWINGS AND SCHEMATICS	40
10.1 Parts Locator, Model 8330i-200 (Pneumo Front Panel)	41
10.2 Parts Locator, Model 8330i-200 (Pneumo Back Panel).....	42
10.3 Parts Locator, Model 8330i-400 (Air Control Front Panel).....	43
10.4 Parts Locator, Model 8330i-400 (Air Control Back Panel)	44
10.5 Parts Locator, Model 2830A-04 (Diver Communications)	45
10.6 Parts Locator, Model 873-400-NV (Regulator)	46
11. PARTS LISTS.....	47
11.1 Air Control System, Model 8330i.....	48
11.2 Air System Control Model 8330iC-01	48
11.3 8330i-200 Pneumo Panel Assembly	48
11.4 8330i-400 Air Control Panel Assembly, Model 8330i & 8330iC-01	49
11.5 Regulator, Pressure Reducing	50
11.6 2830A-04 Front Panel Assembly	51
11.7 Recommended Spare Parts.....	52
12. REPAIR & CALIBRATION LOGS.....	53
12.1 Repair and Maintenance Log for Model 8330i & 8330iC-01	53
12.2 Gauge Calibration Log Model 25545-23B11-HDP.....	54
13. LIMITED WARRANTY AND SERVICE POLICY.....	55

1. INTRODUCTION AND SPECIFICATIONS

1.1 Introduction

The Model 8330i & 8330iC-01 are portable self-contained three-diver high and low pressure air control, depth monitoring (pneumo) systems and optional communications (8330iC-01 Model Only) for surface supplied diving operations. The system is designed to provide a central control point for the supply of breathing air to the divers, monitor the diver's depth, and w/ 8330iC-01, provide two-way communications between the divers and the surface. The system is housed in a durable pressure fused fiberglass case which provides a convenient, compact, rugged, professional system.

1.1.1 Air Control

The Air Control System is designed so that each diver possess their own high-pressure and low-pressure air supplies that are independent of and isolated from the other divers' air supplies. An emergency cross over valve has been designed in as a fail-safe measure.

The Air Control Section consists of three high-pressure inputs, three low-pressure inputs, and three diver air connections.

Each high-pressure input has a shut-off valve and 0-6000 psi gauge.

High-pressure air is reduced to the desired low pressure via an adjustable regulator. The input to the regulator is protected against contamination by a 50-micron filter. Regulator output pressure is adjustable over the range of 0 to 400 psi; a 2 1/2" 0-600 PSI gauge monitors the output pressure. The unit has an over pressurization relief valve, factory set to 350 psi.

The low-pressure inputs are #8 JIC and have a check valve to permit simple switch over from low-pressure air to high-pressure air.

Diver's airline connection is O2 type fitting; control is via 1/4 turn ball valves permitting unrestricted flow.

1.1.2 Depth Monitoring

The diver's pneumo connection is an O2 type fitting; pneumo valves are regulating type. Pneumo gauges are 6" high, precision 0.25% of full-scale accuracy, dual scale 0-250 FSW/0-76 MSW with one-foot increments.

1.1.3 Communications (8330iC-01 Model Only)

The diver communication system is based on the field proven AMCOM III Model 2830A. The unit comes standard with a built-in medical grade internal power supply and can be operated from either a 90-264 V_{AC}, internal 12 V_{DC} battery, or an external 12 V_{DC} power source.

Operating time from fully charged battery is approximately 41 hours. Unit can also be operated from an external 12 V_{DC} source, via charger jacks on the front panel. The communicator has a unique battery condition indicator. Steady GREEN light indicates battery voltage level is good. Blinking GREEN light indicates battery voltage is approaching a low level (approx. 3 hours of operation remain). Steady

RED light indicates battery voltage is below the level necessary to guarantee proper operation.

WARNING: When Battery Condition indicator is steady RED light, communication will stop. The battery condition indicator also functions in the same manner when operating from an external power source.

Possibly the most useful feature of the AMCOM III communicator is the ability to operate the unit remotely. This feature allows the use of a hand-held, push-to-talk microphone (included), or a walk and talk type module (optional). This allows the tender (operator) to move about and still maintain contact with the divers. Optionally the communicator can be equipped with a wireless tender option to allow freedom of movement without wires.

The use of the noise canceling push-to-talk microphone automatically disconnects the speaker when talking to the divers, cutting out the majority of the background noise which greatly improves the intelligibility of communications.

The communicator provides ample voice power. This power level provides the volume necessary to communicate clearly even under difficult conditions. Standard controls include: power on/off, tender volume, diver volume, speaker on/off, 5-way binding post diver input, push-to-talk switch, headset/microphone jack, and remote push-to-talk jacks.

1.2 Specifications Air Control

1.2.1 High Pressure Input

Input Pressure Range	500-5000 PSI
Inlet Valve	3
Gauge - 0-6000 PSI	Accuracy +/- 1.5%
Input Filter, In Line Pre Regulator	50 Micron

1.2.2 High Pressure Regulator

Outlet Pressure Range	0-400 PSI
High Flow	Cv = 0.8
Max Pressure	6000 PSI

1.2.3 Low Pressure Input, with Check Valve

Max Pressure	350 PSI
Inlet Connections (#8 JIC)	3
Diver Outlet Connection, (O2 Fitting).....	3
Diver Outlet Valve (Ball).....	3
Air Pressure Gauge, 0-600 PSI	Accuracy +/- 1.5%
Over Pressure Relief Valve Set Pressure.....	350 PSI

1.2.4 Panel

Material	Stainless Steel
Powder Coating	Black Textured Semi-Gloss Polyester
Silkscreen Graphics	Red, Green, White & Blue

1.3 Specifications Depth Monitoring (Pneumo)

1.3.1 Pneumo Gauge, 3-D Precision

Mirrored Scale, 6 Inch	3
Range	Dual Scale 0-250 FSW/0-76 MSW
Divisions	1 Foot
Accuracy	0.25% of Full Scale

1.3.2 Pneumo Valve

Regulating Valve, KEL-F Seat	3
------------------------------------	---

1.3.3 Outlet Connection

O2 Fitting Chrome Plated Brass	3
--------------------------------------	---

1.3.4 Panel Material

Material	Aluminum
Powder Coating	Black Textured Semi-Gloss Polyester
Silkscreen Graphics	Yellow

1.4 Specifications Communications (8330iC-01 Model Only)

1.4.1 Model 2830A-04, 3-Diver Communicator

Input Impedance (Each Input)	250 Ohms
Frequency Response	300 - 10000 Hz
Common Mode Rejection	40 dB Minimum
Current Drain Maximum Full Volume	3 Amps
Minimum Quiescent	0.190 Amps
Output Impedance	4 Ohm
Power Supply Voltage	12 V _{DC} Nominal (9 V _{DC} Min - 16 V _{DC} Max)
AC Power Operating Range	90-264 V _{AC} , 50-60 Hz
Sensitivity (Input)	0.5 mV
Output Power (RMS @ 4 Ohm Load, 12 VDC)	10 Watts Audio
Panel	Black Powder Coat over Stainless Steel with White Silkscreen Graphics
Battery Life	41 Hours

1.5 Specifications Enclosure

1.5.1 Case Material

Pressure molded fiberglass, with aluminum and or stainless steel hardware. Includes carrying handle, latches, and stay hinge to lock unit in open position (upper section is locked upright in respect to lower section).

1.5.2 Case

Lid closed 24-1/4" W x 19-1/2" D x 14" H

Lid Open 24-1/4" W x 24-1/2" D x 28-1/2" H

Weight: Approximately 108 lbs.

Color: International yellow

2. OPTIONS AND ACCESSORIES

2.1 Model /28A Wireless Tender Option

The communicator is equipped with a wireless module and includes a Model 2829-11 Wireless Tender Headset. The wireless headset allows the tender freedom to move around. It requires the divers to be wired in 4-Wire mode. Additional Wireless Tender Headset can be used by other members of the dive team in listen only mode.

2.2 Model 2821-28 Walk-and-Push-to-Talk (2-Wire Operation)

Designed for 2-Wire applications, the Model 2821-28 provides the tender with mobility around the dive site while maintaining communications with the diver. It comes equipped with a small clip-on belt module that contains a Push-to-Talk switch, connector for the headset, and 25 feet (7.6 meters) of lightweight flexible cable. Custom cable lengths are available.

2.3 Model 2822-28 Remote Walk-and-Talk (4-Wire Operation)

Designed for Full Duplex (4-Wire) applications, the Model 2822-28 provides the tender with mobility around the dive site while maintaining communications with the diver. It comes equipped with a small clip-on belt module that contains the connectors for the headset, and 25 feet (7.6 meters) of lightweight flexible cable. Custom cable lengths are available.

2.4 Model 2460-28 Headset

The Model 2460-28 is a light and comfortable headset designed for extended wear at an economical price. It comes equipped with color-coded, dual banana plugs that mate directly to AMCOM diver communicators as well as a spiral cord that can be extended up to 8 feet (2.4 meters).

2.5 Model 2829-11 Wireless Kit with Case

A heavy-duty headset combined with a wireless belt module that is compatible with the /28A option. One headset comes with communicators ordered with the /28A options but additional headset can be ordered to allow other crew member to monitor communications.

2.6 Model 2405-28 Hand Held Microphone

The Model 2405-28 is a hand-held, noise canceling, push-to-talk microphone that provides excellent sound quality to the diver. It comes equipped with a spiral cord that can be extended up to 6 feet (1.8 meters).

3. SAFETY AND REGULATIONS

Safe diving does not happen by accident. There are few occupations in the world which require such a broad range of knowledge and training as diving. There are many diverse factors which can affect diving safety, i.e. planning, weather, equipment, location, water conditions, as well as the type of work being done. The single most important factor in eliminating accidents is planning and attention to detail. Diving knowledge, training and experience are fundamental elements needed to execute a safe dive.

The following reference materials are recommended as sources of information for running a safe diving operation:

1. U.S. Department of Labor, OSHA Regulations 1910.401 Sub-part T–Commercial Diving Operations.
2. U.S. Navy Diving Manual.
3. Divers Handbook of Underwater Calculations.

3.1 Diving Safety and Regulations

3.1.1 Diving Regulations

Several codes and regulations cover diving operations and procedures. In the United States most commercial diving operations are covered by the OSHA (Occupational Safety and Health Administration) regulations, or individual state regulations, which are adopted from the federal regulations, and made a part of the civil code.

While government agencies are exempt from OSHA regulations, they generally fall under other regulations, which are similar or stricter than OSHA. If they are completely exempt, they must still abide by the procedures for operating a safe dive.

While no agency (within the U.S., for commercial diving operations) tests or approves equipment for use, they do establish minimum standards which should be followed. The suitability of a given piece of equipment for a particular task is left to the supervisor of the dive. The following information is extracted from the OSHA regulations for commercial diving operations.

NOTE: The information is not presented as a direct or complete quotation, but rather as our interpretation of the regulations. Each diving supervisor should obtain a copy of these regulations for their own use.

WARNING: DO NOT USE THE MODEL 8330i & 8330iC-01 FOR THE FOLLOWING:

- Mixed gas diving operations with an oxygen level greater than 25%.
- Oxygen or oxygen enriched breathing mixtures above 25%.

The MODEL 8330i & 8330iC-01 are not designed or intended for these applications.

3.2 Personnel Requirements

1. Each dive team member shall have the experience or training necessary to perform assigned tasks in a safe and healthful manner. The person operating the Model 8330i & 8330iC-01 must be trained in the proper operating procedures and emergency operating procedures.
2. It is the responsibility of the designated person in charge of the diving operation to be on site at all times. He is responsible for all aspects of the diving operation affecting the health and safety of dive team members.
3. The dive shall be terminated when:
 - A diver requests termination.
 - A diver fails to respond to instructions.
 - Diver communications are lost and cannot be re-established quickly.
 - A diver begins to use diver carried back-up breathing air or location reserve breathing air.
 - Operational conditions deteriorate to a point where safe diving cannot be guaranteed.

3.3 Air Supply Requirements

WARNING

Regardless of the type of air supply being used for surface supplied diving; the diver must always have a back-up supply of air. Generally this is in the form of a bailout bottle. The back-up air supply must be adequate to return the diver to the surface; if the dive requires in-water decompression, this must be accounted for also.

1. The diver's air supply may originate from a low-pressure air compressor, high-pressure air cylinders, or a combination of both. Regardless of the source, the air must meet certain established standards of purity and must be supplied in an adequate volume for breathing.
2. The air supply requirements depend upon the specific factors of each dive such as depth, duration, level of exertion, and type of diving system (helmet/hat) being used. It is the dive supervisor's responsibility to ensure that an adequate supply of air is available and on site for the planned dive. This includes sufficient back up air to safely return the diver to the surface in the event the primary supply of air is lost.
3. Low-pressure compressors used for breathing air should be specifically designed for diving. Compressors used to supply air to the divers shall be equipped with a volume tank which has a check valve on the inlet side, a pressure gauge, relief valve, drain valve, and a proper filtration system. The output of the air compressor system shall be tested for air purity every 6 months by means of an air sample.
4. Air compressor intakes shall be located away from and up wind of areas containing exhaust or other contaminants.

5. **NOTE: OSHA regulations require** a decompression chamber capable of recompressing the diver at the surface to a minimum of 165 FSW (6 ATA) shall be available at the dive location for a surface supplied air diving to depths deeper than 100 FSW.

3.4 Calibration, Service and Inspection

1. Each depth gauge shall be dead weight tested or calibrated against a master reference gauge every 6 months or if there is a discrepancy greater than two percent (2%) between any two equivalent gauges.
2. Each equipment modification, repair, test, calibration, or maintenance service shall be recorded by means of a tagging or logging system, and include the date and nature of work performed, and the name of the person performing the work. For your convenience a repair service log is provided at the end of this manual.
3. Equipment Inspection; Prior to each dive, the equipment shall be inspected and checked to ensure that it is in proper working order.

4. CONTROLS & CONNECTIONS

Before using the Model 8330i or 8330iC-01, familiarize yourself with its operating controls and connections. For simplicity, the controls and connections are divided into three categories. The categories are Air Control, Pneumo, and Communications.

4.1 Air Control

The Air Control system consists of a high-pressure section and a low-pressure section. The system is designed to supply breathing air to a diver through an umbilical. This is known as surface supplied diving. The air the divers are breathing is supplied from the surface.

4.1.1 High-Pressure

The HP system accepts breathing air from HP bottles or any other suitable source, i.e. high-pressure flasks. The pressure is reduced to a level suitable to the needs of the diver via a pressure-reducing regulator. The pressure required by the diver is determined by the type of helmet/hat being used and the depth the diver is working at. The general rule of thumb is bottom pressure plus over-bottom pressure required for a given type of diving helmet / hat. Consult your diving helmet / hat manufacture/manual for the requirement of the helmet / hat you are using.

Each Diver has its own High-Pressure run that consists of an HP Input Connection, Inlet Shut-off Valve, Gauge, Inline Filter and a Pressure-Reducing Regulator.

1. Diver 1, Diver 2, and Diver 3 inlet valve handles are color coded Green, Red and Blue. This helps the operator identify which valve controls which Diver. For maximum airflow, turn handle counter clockwise four (4) full turns. To shut-off valve, turn handle clockwise until it stops.
2. Inlet gauge reads actual input pressure of air source. Gauge pressure range is 0-6000 psi; accuracy is 1-1/2% of full scale.
3. A pre-regulator filter prevents debris from contaminating the regulator. Filter element is 50 micron.
4. High pressure regulator(s) reduce pressure of incoming air from high-pressure bottles to a level required by diver's helmet / hat. To increase the diver's air pressure, turn knob clockwise to desired setting. To decrease the diver's air pressure, turn knob counter clock-wise.

4.1.2 Low-Pressure

The Low-Pressure Run for each diver consists of an LP input connection with a controlling 1/4 turn Ball Valve, a low pressure output from the regulator with a controlling 1/4 turn Ball Valve, Gauge, Outlet 1/4 turn Ball Valve and Diver Connection. A small portion of the LP air is also used when diver depth measurements are made.

The LP system accepts breathing air from a low-pressure source i.e., a low pressure diving air compressor. Note: The low-pressure section does not regulate the air pressure to the diver. The compressor must be set to provide the proper pressure to the diver.

Breathing air from the low-pressure side of the regulator or the low-pressure input is routed to the diver's breathing air connections. A portion of the low-pressure air is used by the pneumo section for diver depth measurements.

1. Low-pressure input, #8 JIC type fitting. (O₂ type fitting available).
2. Low-pressure check valves prevents the back flow of air from the HP regulator outputs into the LP air sources. This also permits simple switch over from LP to HP air
3. 1/4 Turn ball valves controls flow of air to divers. Ball valves permits unrestricted flow.
4. Divers air supply gauges reads air pressure to divers, 0-600 PSI.
5. Divers air supply outlet connections, O₂ (oxygen) type fitting. (37° JIC optional).
6. Pressure relief valve, factory set for 350 PSI, vents excess pressure to atmosphere. Vent is located in the upper right hand corner.

4.2 Depth Monitoring

The Pneumo Fathometer section is used to measure the diver's depth. Pneumo readings are made by pressurizing the diver's pneumo hose. Air is forced through the pneumo hose until all water is displaced. The air is then shut off and the pressure is read on a high accuracy gauge calibrated in FSW (feet of seawater). The system components are:

1. Diver pneumo valve (yellow handle) controls the air supply to the Pneumo Fathometer system, one for each diver.
2. Pneumo gauge, dual scale 0-250 FSW/0-76 MSW, mirrored scale, 6 inch, high precision, 0.25% of full scale accuracy, one for each diver.
3. Diver pneumo outlet connections are O₂ (oxygen) type fittings. (37° JIC fitting optional).

4.3 Communications (8330iC-01 Model Only)

Before using the 8330iC-01 diver communicator, the operator should be familiar with all the controls and connections. While reading this manual, you will find capitalized words such as PANEL SPEAKER. These words are to remind the reader that additional information can be found in this section of the manual.

4.3.1 Tender Controls

The following controls are located on the front panel of the communicator. For location of controls, please refer to Section 10.5 Parts Locator, Model 2830A-04.

1. **POWER SWITCH** - The power on/off control.
2. **SPEAKER SWITCH** - This switch allows the tender to turn off the speaker. If the tender is using a headset, it may be necessary to turn off the speaker in order to prevent acoustic feedback.
3. **PUSH-TO-TALK ALL BUTTON** - This pushbutton allows the tender to talk to all the divers when operating in 2-Wire mode. It is not necessary to use this control in the Full Duplex (4-Wire) mode. When using Full Duplex mode, this control allows the tender to interrupt the diver by forcing the diver into listen only mode.
4. **EARPHONE VOLUME** - This control sets the volume for the tender's earphone and/or PANEL SPEAKER. Rotate this knob clockwise to increase the volume from all the divers.
5. **MICROPHONE VOLUME** - This control sets the level for the tender's microphone and/or PANEL MICROPHONE. Rotate this knob clockwise to increase the tender's volume to all the divers.
6. **PANEL SPEAKER** - A waterproof, acoustic speaker that allows the tender to monitor communication to the diver and act as a microphone by using the PUSH-TO-TALK BUTTON. The volume level is controlled by the EARPHONE VOLUME control and it can be turned off using the SPEAKER SWITCH.
7. **PANEL MICROPHONE** - A water resistant, condenser microphone that allows the tender to talk to the divers the PUSH-TO-TALK BUTTONS. The volume level is controlled by the MICROPHONE VOLUME control and it is turned off when the SPEAKER SWITCH is off.
8. **BATTERY CONDITION INDICATOR** – Steady GREEN light indicates battery voltage level is good. Blinking GREEN light indicates battery voltage is approaching a low level (approx. 3 hours of operation remain). Steady RED light indicates battery voltage is below the level necessary to guarantee proper operation. **WARNING:** When Battery Condition indicator is steady RED light, communication will stop. The battery condition indicator also functions in the same manner when operating from an external power source.

4.3.2 Tender Connections

1. **TENDER HEADSET** - This is the dual banana jack (color-coded black) that functions as both an output (earphone) and input (microphone) for the tender as controlled by the PUSH-TO-TALK BUTTON and PUSH-TO-TALK JACK. Using this connection, the tender can be wired in either 2-Wire or Full Duplex (4-Wire) mode regardless of the mode used for the diver.

To connect the tender in the Full Duplex (4-Wire) mode, connect the earphone (black) banana plug of the headset to this jack and the microphone (red) to

the TENDER MICROPHONE jack (red).. In this mode, the tender does not have to use the PUSH-TO-TALK BUTTON to communicate with a diver who is also connected in the Full Duplex (4-Wire) mode. This configuration can be used even if the diver is connected in 2-Wire mode. In that situation, the tender is required to use the PUSH-TO-TALK BUTTON or PUSH-TO-TALK JACK.

The headset microphone is always active which means that there can be acoustic feedback between the PANEL SPEAKER and the microphone if the tender is near the communicator. To prevent this, the PANEL SPEAKER can be turned off using the SPEAKER SWITCH. Another option is to move the tender away from the communicator by using the Amron Model 2822-28 Walk-and-Talk Module accessory. This allows the tender to communicate while other members of the surface crew listen using the PANEL SPEAKER. This module comes with 25 feet (7.6 meters) of cable (custom cable lengths are available).

The tender can also be connected in 2-Wire mode by stacking both the earphone (black) and microphone (red) banana plugs into this jack. The diver does not have to be connected in 2-Wire mode if the tender is in 2-Wire mode. In order to talk to the diver, the tender must use either the PUSH-TO-TALK BUTTON or PUSH-TO-TALK JACK. Since the headset microphone is not active until one of the push-to-talk methods is used, there is no chance for acoustic feedback to occur and surface conversation or noise is not transmitted to diver and the PANEL SPEAKER can be left on. This may, for some situations, make for a better overall diving experience. If the tender requires more mobility at the dive site, the Amron Model 2821-28 Remote Push-to-Talk Module can be used to extend the headset cable. It includes a push-to-talk button on a clip-on belt module and comes standard with 25 feet (7.6 meters) of cable (custom cable lengths are available).

The tender may also use the optional Amron Model 2405-28 Push-to-Talk Microphone. This microphone comes with two color-coded banana plugs. The black plug goes into the TENDER HEADSET jack and the yellow plug goes in the PUSH-TO-TALK JACK. To communicate with the diver, the tender presses the button on the side of the microphone. There is no chance of acoustic feedback since the PANEL SPEAKER is cut-off when the tender uses the microphone. When using the Push-to-Talk Microphone, the SPEAKER SWITCH must be turned on in order to hear the diver.

2. **TENDER MICROPHONE** - This is a dual banana jack (color-coded red) that functions as the microphone input from the tender's headset. It is only used if the tender is in Full Duplex (4-Wire) mode.
3. **PUSH-TO-TALK JACK** - This is a dual banana jack (color-coded yellow) that allows for remote keying of the push-to-talk function of the communicator. The difference between using the PUSH-TO-TALK JACK and PUSH-TO-TALK BUTTON is that the button allows the tender to communicate using the PANEL SPEAKER as a microphone. If both are used at the same time, the PANEL SPEAKER is active as a microphone. This allows a crew member to

talk to the diver using the PANEL SPEAKER even if the tender is away from the communicator using the Remote Push-to-Talk Module in 2-Wire mode.

4. **EXTERNAL BATTERY JACK** - The communicator can be powered using an external battery or power supply via the two color coded TIP jacks. The red TIP jack is the positive power input and the black is the negative power input. The input voltage must be between 9 and 18 VDC and must be able to supply a peak current of 3 Amps for proper operation. The following warnings need to be heeded when using the EXTERNAL BATTERY JACK. A minimum wire size of 18 AWG and maximum wire run of 3 feet (1 meter) is recommended.

Note: If you use an external power supply, the maximum voltage cannot exceed 16 Volts.

5. **RECORDER OUTPUT** - This is a single RCA Phono jack (color-coded black) that provides a transformer isolated of both the diver and tender communications. It is designed to drive the standard line-level inputs of audio or video recorders with input impedances as low as 600 Ohms.

4.3.3 Diver Controls (separate controls for each diver)

1. **TENDER-TO-DIVER VOLUME** - Adjusts volume from Tender-to-Diver.
2. **DIVER-TO-TENDER VOLUME** - Adjust volume from Diver-to-Tender.
3. **PUSH-TO-TALK (DIVER 1, 2 & 3)** – These pushbuttons switches the specific diver to listening mode as long as the pushbutton is depressed. The specific diver can hear the tender and all other divers. It is primarily used in the 2-Wire mode but can be used to temporarily block a single diver's microphone in 4-Wire mode.

4.3.4 Diver Connections

1. **DIVER MICROPHONE** - This is a dual 5-way binding post jack (color-coded red) that functions as both an output (earphone) and input (microphone) for the diver as controlled by the PUSH-TO-TALK BUTTON and PUSH-TO-TALK JACK. Using this connection, the diver can be wired in either 2-Wire or Full Duplex (4-Wire) mode regardless of the mode used for the diver.

To connect the diver in Full Duplex (4-Wire) mode, connect the diver microphone to this jack and the diver earphone to the DIVER EARPHONE jack. The diver can use this mode even if the tender is wired in 2-Wire mode.

To connect the diver in 2-Wire mode, connect both the diver microphone and earphone to this jack. If the diver umbilical uses banana plugs, simply stack both plugs into this jack. In this mode, the diver microphone will be active and heard on tender headset and/or PANEL SPEAKER unless the PUSH-TO-TALK BUTTON or PUSH-TO-TALK JACK is activated.

2. **DIVER EARPHONE** - This is a dual 5-way binding post jack (color-coded black) that functions as the output for the diver's earphone. It is only used when the diver is in Full Duplex (4-Wire) mode.

5. PRE-DIVE PROCEDURES

5.1 Pre-Dive Set-Up

1. Place Model 8330i & 8330iC-01 on flat surface that can support the unit. Select a working area which is secure, stable, convenient, and suitable for use during the period of the dive.
2. Conduct a visual inspection of unit to insure no damage has occurred during transportation to the job site, or since the last time the unit was used.
3. Attach HP Supply to Diver 1 HP inlet
4. If available, a low pressure compressor should be used as the primary air supply and HP cylinders used as a back-up air source.

Note: Low pressure compressors used for breathing air should be specifically designed for diving.

5. All customer supplied hose whips should be clear of debris and have their open ends taped, capped or plugged when not in use.
6. Flush out low pressure hose whip before connecting to the Model 8330i & 8330iC-01 to prevent debris from entering system.
7. Attach hose whip to Diver 1 LP supply inlet fitting.

Note: When tightening hoses, USE TWO WRENCHES place one wrench on inlet fitting and hold, turn hose fitting with a second wrench making sure not to over tighten.

5.2 Pre-Dive Check Out

1. Be sure both the high pressure valve, pneumo valve, and air supply valve are in the 'off' (closed) position.
2. Regulator should be set to a low pressure, turn knob counter clockwise until the knob stops.
3. Turn the Diver output valve and pneumo valve to 'off' position.
4. Turn on HP supply. **Note:** Always open high pressure valves slowly, allow system to fill slowly before opening valves for maximum flow.
5. Turn on Diver 1 supply valve by turning counter clockwise four (4) full turns.
6. Note the cylinders air pressure by reading the HP supply gauge.
7. Adjust regulator to desired setting by turning knob while monitoring the diver air supply gauge. Clockwise increases the set pressure.

Note: Regulator setting is determined by: required over-bottom pressure for manufacturer's helmet or mask plus the bottom pressure relating to the diver's depth. See section 9.4 for gauge pressure verses depth chart.

5.3 Pre-Dive Pneumo Test

A Pneumo gauge with a range of 250 FSW/76 MSW has an equivalent full-scale pressure rating of 111.25 PSI. If you exceed this pressure by a significant amount you will cause a permanent change in the calibration of the gauge. If you exceed 111 PSI by 100% you will destroy the gauge.

Procedure for checking the pneumo gauges:

1. Pressurize the LP section of the 8330i & 8330iC-01; reduce the output pressure of the regulator to a pressure less than 100 PSI.
2. Open the diver output valve momentarily to reduce the pressure and check the action of the regulator. Check to see that the output of the regulator stays at less than 100 PSI.
3. Open Pneumo valve slowly, while watching the depth gauge, check that the gauge needle is slowly rising and that air is exhausting through the diver's pneumo connection (or diver's pneumo hose if connected).
4. Close valve; check depth gauge to see that it reads zero. The gauge should be within +/- 10 feet of zero. Zero will be affected by changes in atmospheric pressure and/or changes in altitude. If zero is off by more than 10 feet and there has not been a significant change in either atmospheric pressure or altitude, suspect that the gauge has been subjected to over-pressurization and may have suffered damage. Cross-check the gauge or have the gauge calibrated before using.
5. Seal the output of the pneumo section. This can be done by capping off the Pneumo output, or preferable sealing the end of the pneumo hose. Pressurize the Pneumo to 200 FSW and close the blow-down valve. This reading should hold, with out a decrease in reading. If the reading decreases you have a leak in the system, correct before proceeding.
6. Cross-checking the pneumo gauges. Either connect the pneumo outputs together, or connect the pneumo hoses together and pressurize the system, both gauges should read the same. If the gauges differ by more than 2%, have the defective gauge calibrated. Gauge calibration should be compared at several points over the range of the gauge, with both increasing and decreasing pressure. As a minimum check the gauges over the range which the gauge will be used.

5.4 Pre-Dive Testing Communications (8330iC-01 Model Only)

1. Always test the communications between the AMCOM III and divers before each dive. Connect the diver's umbilical to the diver communicator, and the helmet / hat to the umbilical.
2. Turn power to "ON" position.
3. Set "Tenders Volume" at mid scale. While diver is speaking, adjust to a comfortable level.

4. Set “Divers Volume” at mid scale. Talk to diver and adjust until diver can hear tender at a comfortable level. If you are using a 2-wire system you must use the “Push-to-talk” switch, or the push-to-talk “Hand-Held Microphone”.
5. Become familiar with the “Push-to-Talk” switch by pushing the switch when talking to the diver. **Note:** If switch is depressed, tender can not hear diver. Diver cannot hear tender if tender does not actuate the “Push-to-Talk” switch.
6. Check Diver 2 and 3 diver communication.

5.5 Connecting Diver Umbilical

1. Remove protective caps and attach diver air supply and diver pneumo hose fittings to corresponding outlets. **Note:** When tightening, place one wrench on outlet fitting and one wrench on hose fitting. Tighten hose fitting, making sure not to over tighten.
2. Blow out diver’s air supply hose to insure no debris is in the line before connecting to a helmet or mask.

Connect the communication cable (surface end) to the two binding posts located on the right side of radio. Wires should be well fastened to the binding posts and not touching each other (bare wire). We strongly recommend the use of dual banana plugs attached to the top side end of the umbilical. This ensures a good connection and reduces the possibility of shorts and/or intermittent connections. Attach diver’s end to helmet or mask.

Test the operation of the system.

5.6 Low Pressure Supply

Test LP supply with low pressure compressor.

Note: Adjust diver air supply pressure at compressor. The 8330i & 8330iC-01 LP supply system by-passes the regulator, therefore, cannot control air pressure entering system, or the pressure to the diver.

6. OPERATING PROCEDURES

6.1 Low Pressure Breathing Air (Primary Supply)

Low Pressure Compressor (Primary supply), High Pressure (Backup). In this mode of operation the divers breathing air is being supplied by an LP compressor, the HP Supply is use as a back-up supply. Having the HP supply as a backup does not eliminate the requirement for a bailout source of air.

In the event the LP air source fails, it is a simple matter to switch over to HP Air. Turn "ON" the HP source by opening the HP valve. Check the diver's air supply pressure.

6.2 High Pressure Breathing Air (Primary Supply)

In this mode of operation the divers breathing air is being supplied by via high pressure breathing air source. This could include high pressure storage cylinders, or a bank of high-pressure storage cylinders.

1. When planning your dive you must take into consideration the amount of time a given bottle will last and the number of bottles, which will be necessary during the dive. There are two options that can be used to accommodate dives that will have a high consumption of air.
2. Use twin tanks instead of singles. Use a high volume cylinder (250 - 300 cubic feet) of breathing air; these can generally be rented from a welding gas supplier, or supplier of industrial gases. Make sure you specify breathing air, and request certification. These cylinders can be also be manifolded quite easily. Generally the charge for rental is very competitive in cost and usually includes delivery to the job site.

Note: When using high-pressure cylinders, care must be exercised in the handling, transport and storage of it. Make sure all personnel involved are instructed in the proper procedures. If you have any questions regarding the proper procedures contact your supplier.

6.3 Pre-Operation Checklist

1. Diver dressed and ready except helmet / hat
2. Diver's umbilical organized
3. LP Compressor running and at pressure
4. HP source connected and ready, HP-1, HP-2 & HP-3 valves "OFF"
5. Zero Pneumo Gauges
6. Diver air ON, purge diver Helmet / hat
7. Diver dons helmet / hat
8. Diver communicator ON, Comm check.
10. Diver air check

11. Diver enters water
12. Record the starting time of the dive

During the dive, the tender shall maintain voice communication with the diver at all times. Tender shall monitor diver's air pressure and breathing rate

6.4 Pneumo Readings

During the dive, the tender shall monitor the diver's depth, recording the depth and time at depth. The procedure for measuring depth is as follows.

1. Advise the diver that a pneumo reading is to be taken.
2. The diver will place the end of the pneumo hose at the point at which the measurement shall be taken. Diver will advise the tender he is ready for the pneumo reading.
3. Slowly open the Pneumo valve corresponding to the diver whose depth is being measured. The Pneumo gauge reading will increase and stabilize at a value greater than the depth of the diver. The value will depend upon the flow rate, and pressure drop over the length of the pneumo hose. The diver will advise the tender of bubbles coming from the end of the hose.
4. Close the pneumo valve, the reading will begin to decrease to the value of the diver's depth. Once the reading has stabilized, this is the depth at the end of the pneumo hose.

Note: Pneumo readings can be used for several purposes i.e., measuring the diver's depth, depth to a particular point under water, vertical distance from one underwater object to another. The accuracy of the measurement is plus or minus 0.625 feet of seawater, (+/- 7.5 inches). This represents an overall accuracy of +/- 1/4 of 1% of the full-scale value of the depth gauge. To maintain this accuracy the gauges must be calibrated every 6 months.

When using the pneumo system to measure the diver's depth for use in determining decompression requirements, please note the following:

6.4.1 Definitions of terms, PAR 7.1

DEPTH - When used to indicate the depth of a dive, it means the maximum depth attained by any part of the diver during the dive, measured in feet of seawater.

6.4.2 Selection of decompression Schedule, PAR 7.2.3

- (A) Always select the schedule depth to be equal to or the next depth greater than the actual depth to which the dive was conducted, and
- (B) Always select the schedule bottom time to be equal to or the next longer bottom time than the actual bottom time of the dive.

6.4.3 Rules during ascent, PAR 7.4.1

Decompression Stop Depth - The diver's chest should be located as close as possible to the stop depth.

The above information is quoted from the U.S. NAVY DIVING MANUAL, Chapter 7, Air Decompression.

6.5 Diver Communications (8330iC-01 Models Only)

The AMCOM SERIES III can be operated in two basic modes of operation. The conventional method of operation is known as 2-wire, this allows the diver to be heard by the tender, but requires the operator/tender to actuate the Push-To-Talk switch in order to talk to the diver. The modern method of operation allows two way conversations to be carried on simultaneously. Amron calls this method of operation "FULL DUPLEX". The diver and tender can talk to each other as you would on a telephone. The same applies to diver to diver conversations. Amron tries to encourage the use of FULL DUPLEX for superior communications and safety.

The Model 2830A-04 has the capability of 2-wire and/or FULL DUPLEX (4-wire) communication modes. FULL DUPLEX and 2-wire can be used simultaneously (mixed), divers on FULL DUPLEX, tender on 2-wire.

2-wire communication is defined as a single communication path. The diver is the priority signal path, tender listens to diver. Signal reversing is accomplished by pushing the Push-To-Talk switch; diver hears tender. Often times a 4-conductor (4 wires) common cable is used with two wires tied together as a pair (this is done for redundancy.), however this is still a 2-wire system.

FULL DUPLEX communication is defined as a dual communication path; a signal path (a pair of wires) for up-link and a signal path (a pair of wires) for down link. A common example of FULL DUPLEX like communication is the telephone. This permits the freedom of natural communication, lower system noise, and diver to diver communication without having to use a cross-talk switch.

6.6 2-Wire Operation (Refer to 6.9)

To connect the diver in 2-Wire mode, connect the communication umbilical wires to the DIVER MICROPHONE binding post jack on the communicator as shown in the wiring drawing in Section 6.9. If the umbilical uses a banana plug, simply insert the plug into the binding post jack. Verify that it is firmly and completely seated. This may require that the external plastic nut be tightened down. If the umbilical uses bare wires, loosen the external plastic nut of the binding post jack. Either insert the bare end of the wire into the hole in the metal shaft of the binding post or firmly wrap the wire around the shaft. Tighten the nut until the bare wire is firmly fastened by the nut. The nut should not be fastened on the insulation of the wire nor should any of the bare wires touch.

The tender can operate in 2-Wire without a headset or push-to-talk microphone by using the PANEL SPEAKER as both a speaker and microphone. When the tender wants to talk to the diver, he presses the PUSH-TO-TALK BUTTON on the front panel and speaks clearly into the PANEL SPEAKER at a distance of between 4 to 8 inches (10 to 20 cm). When done speaking, the tender releases the PUSH-TO-TALK BUTTON to allow the diver to communicate.

When using the Amron Model 2405-28 Push-to-Talk Microphone, the tender presses the push-to-talk button on the side of the microphone and speaks clearly at a distance of between 1 and 2 inches (25 to 51 mm). When done speaking, the tender releases the push-to-talk button to allow the diver to communicate.

Whenever either the diver or the tender are connected in 2-Wire, the tender must use one of the push-to-talk methods when talking to the diver.

6.7 4-Wire Operation (Refer to 6.10)

To connect the diver in Full Duplex (4-Wire) mode, connect the communication umbilical wires to the DIVER MICROPHONE and DIVER EARPHONE jacks as shown in wiring diagram in section 6.10. If the umbilical uses a banana plug, simply insert the plug into the correct binding post jack. Verify that it is firmly and completely seated. This may require that the external plastic nut be tightened. If the umbilical uses bare wire ends, loosen the external plastic nut of the binding post jack. Either insert the bare end of the wire into the hole in the metal shaft of the binding post or firmly wrap the wire around the shaft. Tighten the nut until the bare wire is firmly fastened by the nut. The nut should not be fastened on the insulation of the wire nor should any of the bare wires touch.

The tender will have to use the PUSH-TO-TALK BUTTON to communicate if the diver is in 2-Wire mode. When the tender uses a headset, the SPEAKER SWITCH should be turned off to prevent acoustic feedback. Acoustic feedback can also be avoided by moving the tender away from the communicator by using the Amron Model 2822-28 Remote Walk-and-Talk Module. In this way, the PANEL SPEAKER can allow other members of the diving crew to monitor the dive operation or to communicate to the diver by pressing the PUSH-TO-TALK BUTTON and talking into the speaker.

6.8 Setting the Volume Controls

6.8.1 2-WIRE MODE

Turn power switch to ON, turn speaker switch to ON, and adjust both volume controls to mid-scale. Tender has to depress PUSH-TO-TALK BUTTON in order to talk to diver. Tender and Diver talk to each other during Tender adjusting volume controls as below:

DIVER TO TENDER VOLUME - While diver is talking, tender adjusts this volume control to a comfortable hearing level.

TENDER TO DIVER VOLUME - While tender is talking into the panel speaker and depressing PTT switch, tender adjusts this volume control to a comfortable diver hearing level.

6.8.2 FULL DUPLEX (4-WIRE) MODE

Turn power switch to ON; turn speaker switch to OFF; adjust both volume controls to mid-scale. Tender to use headset. Tender and Diver talk to each other during Tender adjusting volume controls as below:

DIVER TO TENDER VOLUME-While diver is talking, tender adjusts this volume control to a comfortable hearing level.

TENDER TO DIVER VOLUME-While tender is talking; tender adjusts this volume control to a comfortable level for the diver.

6.10 Drawing, FULL DUPLEX (4-Wire) Connections

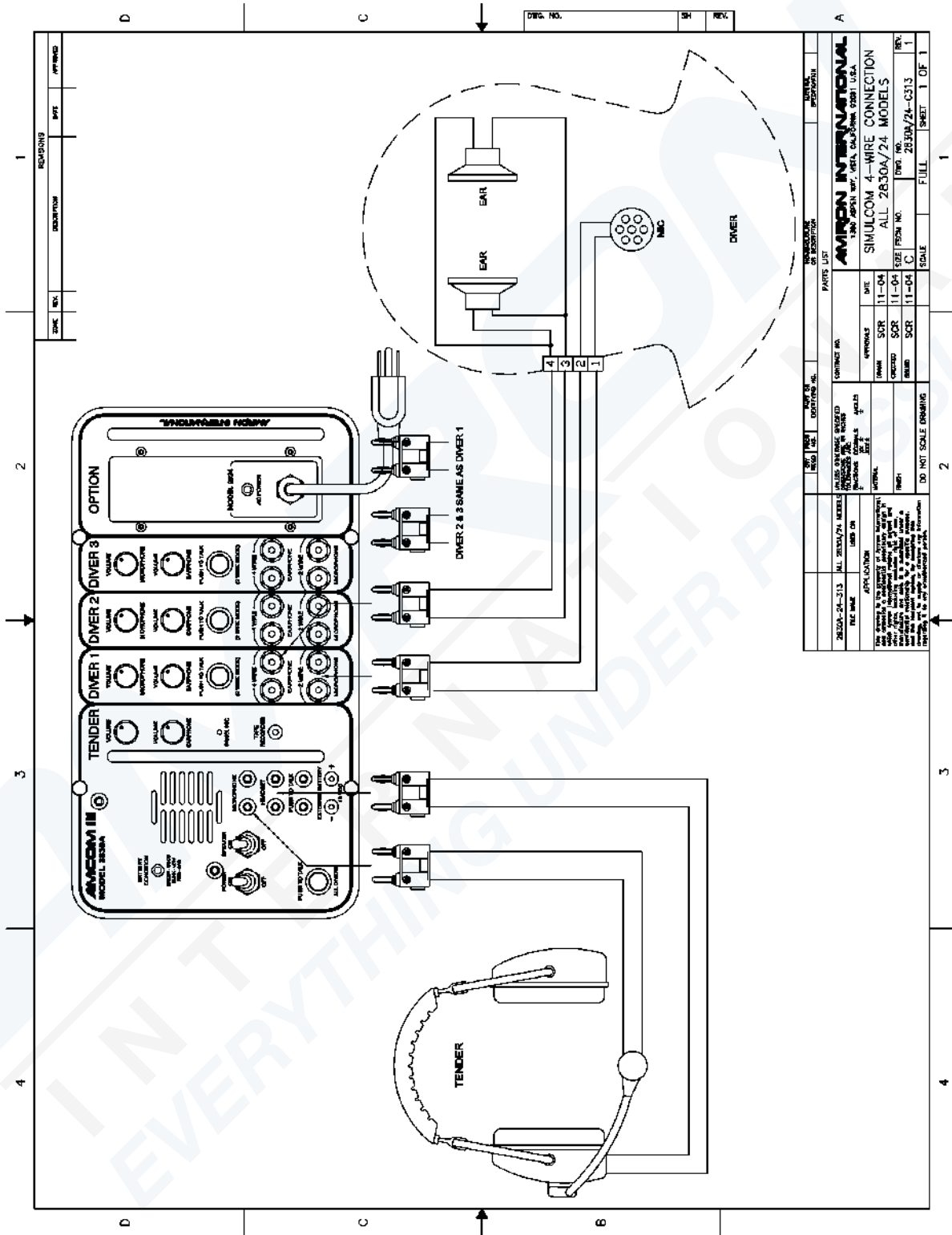

PARTS LIST		DRAWING REVISIONS	
REV.	DATE	BY	DESCRIPTION
MODEL 8330A/24 ALL 2830A/24 MODELS (EXCEPT THE 2830A)		CONTRACT NO. DATE ORDER NO. CHECKED BY DRAWN BY	
APPLICATION THIS DRAWING IS SUBJECT TO AMRON INTERNATIONAL'S PATENT RIGHTS AND IS NOT TO BE REPRODUCED OR TRANSMITTED IN ANY FORM OR BY ANY MEANS, ELECTRONIC OR MECHANICAL, INCLUDING PHOTOCOPYING, RECORDING, OR BY ANY INFORMATION STORAGE AND RETRIEVAL SYSTEM, WITHOUT THE WRITTEN PERMISSION OF AMRON INTERNATIONAL.		AMRON INTERNATIONAL 1200 JOHN WAY, RPT. C, CHENNAI 600112, INDIA ALL 2830A/24 MODELS SIMULCOM 4-WIRE CONNECTION MODEL 8330A/24 MODELS Dwg. No. 2830A/24-0313 REV. 1	
DO NOT SCALE DRAWING		SCALE	SHEET 1 OF 1

7. MAINTENANCE

7.1 Review of Scheduled Maintenance

The inherent quality of your AMCOM III will provide years of continuous failure-free service if properly used and maintained.

1. Before and after each dive: do functional test, clean and inspect for damage.
2. Every 6 months: calibrate, functional test, clean and inspect for damage.
3. Every 12 months: in addition to the normal 6-month maintenance, service filter, leak test and check adjustments.
4. Every 36 months: in addition to the normal annual service replace all seals, gaskets, soft goods, and battery.

In addition to the above scheduled maintenance, there are three important areas of user care that will determine the length of service you can expect from your equipment.

1. Take care of your equipment, protect it, and handle it with care during transportation to the job site. Ensure the equipment is protected. Select a work area where the equipment will be out of everyone's way, so that it doesn't get knocked over.
2. Clean your equipment. After the work is done at the job site, clean up the equipment. If you are on an extended work program, have the equipment operators clean the equipment during slow work periods. Cleaning involves wiping off the dirt with hot soapy water and a soft cloth. Soft Scrub, paint thinner, mineral spirits & turpentine can be used, if necessary, to clean only the case. Clean the terminals (diver communicator connections), using a solution of mild vinegar and a small brush.
3. Charge the batteries after each use; preferably leave the unit on charge when the equipment is not in use.

7.2 Air Control Scheduled Maintenance

7.2.1. Before and after each dive:

Inspect for any damaged parts, broken gauges, condition of high-pressure hose whip (inspect for cuts, abrasion, or general deterioration). Functional test of unit prior to dive, after dive record operator comments regarding maintenance required.

7.2.2. Every 6 Months:

Complete the "Before and after each dive" inspection. Each diver pneumo gauge must be calibrated. Calibrate against dead weight tester or reference gauge. Pressure test PNEUMO section and repair any and all leaks. Record the results of inspection and gauge calibration.

7.2.3 Every 12 months: complete the above tests plus the following:

1. Remove high-pressure valve stems, inspect, clean, lubricate (use Christolube grease, Amron part No. MCG-111-20Z) and install. Check valve seat, threads, packing material for signs of wear or deterioration, replace if necessary.
2. Remove filter element and inspect. If filter element is dirty, make a determination as to where the contamination is coming from. Check the air source being used to determine where the contamination is coming from and correct. If filter is contaminated, remove high pressure section and clean all valves, inspect for signs of wear and deterioration, replace those parts which show signs of deterioration, clean and reassemble.
3. Check regulator action, check regulator maximum pressure which should be greater than 300 PSI.
4. Check relief valve actuation and shut off. Should vent at 350 PSI, close at 345 PSI sealing bubble tight.
5. Check all valves for bubble tight shut off. Replace seats as needed.
6. Leak test all fittings, pressure test PNEUMO section.
7. Check accuracy of all gauges.
8. Record the results of the above tests.

7.2.4 Every three years, in addition to the above test:

1. Replace all soft goods, seals, gaskets and batteries.
2. Record the results of the above tests.

7.3 Communicator Maintenance

The AMCOM III 2830A-04 diver communicator is designed to provide years of continuous, failure-free service when properly used and maintained. There are a few important things that the user can do to extend the life of their equipment.

- Handle the diver communicator with care. Do not throw it around or drop it. Select a work area where the communicator and wire connecting to it are out of everyone's way so it does not get knocked over.
- Clean the communicator after use or when needed. If the equipment is on an extended work program, have the tender clean the equipment during slow work periods. Rinse off salt deposits with fresh water. Clean the diver connections with a mild vinegar and water solution using a soft brush. Rinse off the connectors with water after cleaning.
- When using a rechargeable battery, the battery should be recharged after use or as soon as possible when the BATTERY CONDITION INDICATOR starts blinking.

7.3.1 Recommended Maintenance Schedule

The following sections outline the recommended scheduled maintenance for the diver communicator.

1. **Daily Maintenance** - Wipe off any accumulated salt or salt spray on the front panel or connectors using a clean, damp cloth. Pay particular attention to where the various front panel components attach to the panel. Inspect the outer case for any damage.
2. **Weekly Maintenance** - Wipe off any accumulated salt or salt spray on the front panel or connectors using a clean, damp cloth. Pay particular attention to where the various front panel components attach to the panel. Inspect the outer case for any damage.
 - Inspect the PUSH-TO-TALK BUTTON, binding posts and volume controls for smooth operation.
3. **6 Month Check** - Wipe off any accumulated salt or salt spray on the front panel or connectors using a clean, damp cloth. Pay particular attention to where the various front panel components attach to the panel. Inspect the outer case for any damage.
 - Inspect the PUSH-TO-TALK BUTTON, binding posts and volume controls for smooth operation.
 - Inspect the front panel gasket for any damage and replace if necessary.
 - Recharge the battery.
 - Perform the 2-Wire and Full Duplex (4-Wire) system checks as described in section 8.4.
4. **Yearly Check** - For maximum service life, it is recommended that the diver communicator be sent back to Amron for a yearly check.
5. **Long Term Storage** - If the diver communicator is to be stored for a period greater than 30 days, it is recommended that it be stored in a cool dry location. Make sure that the POWER SWITCH is turned off during storage.

8. TROUBLESHOOTING

8.1 General Information

Normal shop tools and procedures apply for all repairs.

During this section when you are instructed to remove a part or make an adjustment, you are first to remove all pressure from the system, or as a minimum from the section you are working on

8.1.1 Tubing and Tube Fittings

Repair, assembly, and inspection procedures. The common cause of leaks on tube fittings are debris, cracks, and deformed tube flares. Tube fittings, on initial make up tighten 1-1/4 turns from finger tight. To remake tube fittings, tighten finger tight plus 1/8 turn. Care must be used when disassembling tube fittings to ensure the fitting is held while the tube nut is turned.

8.1.2 Pipe Fittings

An over tightened pipe fitting is the most common cause of leaks. Before installing pipe fittings, remove all old Teflon tape, use stiff bristle brush. Replace Teflon tape by wrapping 1-1/2 turns of 1/2 inch tape, counter-clockwise on the threaded portion of the fitting. Use care when installing Teflon tape, leave one full turn of thread exposed and uncovered. This insures that a piece of tape does not get cut off and enter the system during the installation of the fitting.

8.1.3 To Remove a Panel

From the case (either the upper, lower, or communicator), you will need to remove the air hose connecting the lower panel to the upper panel. Loosen the fitting on the lower panel, use two wrenches, and disconnect the hose.

8.1.4 Remove the Diver Communicator

Before attempting to remove the upper panel, loosen and remove the four screws on the front panel of the communicator. Remove communicator out of panel and set aside. Remove the upper panel by removing the screws from around the perimeter of the panel. The upper panel can now be removed from the case.

8.1.5 Removing the Lower Panel

This is the same procedure as the upper. When the lower panel is removed, the case will want to tip over backwards because of the unbalanced weight, support the upper panel or remove the stay hinge and lay the upper panel down. To install the panel back in the case, install all screws before tightening any of the screws. This allows the panel to be shifted to facilitate the alignment of the screw holes in the panel.

8.2 Air Control

8.2.1 HP Gauges

Inspect for leaks. Any leak other than the input fitting is cause to replace the gauge. Internal leaks may cause the gauge face to bulge, if this occurs replace gauge. Inspect gauge blow-out plug for damage. Check accuracy of gauge against reference gauge. Gauges are not repairable, nor can they be adjusted. Discard and replace if problems are encountered.

8.2.2 HP Valves

These are repairable. Remove stem by removing handle and stem packing nut, unscrew stem. Inspect stem, stem screw threads, valve body screw threads, brass packing washer, Viton O-ring, and stem seat (KEL-F). Repair kits are available and include a complete stem assembly. Lubricate stem screw threads and Viton O-ring with Chris-o-lube grease, install stem assembly, and permanently tighten packing nut.

8.2.3 HP Filter

This is a replaceable element. The Maintenance Kit is available from Amron and contains the element, body gasket, and retainer spring. Check with soap and water to ensure filter is not leaking.

8.2.4 HP Regulator

If regulator shows signs of continuous venting or regulator creep, suspect damaged or dirty main valve seat, discontinue use of regulator immediately and switch over to a secondary air source. Refer to 10.6.

8.2.5 Regulator Repair Kit

Repair kit 979-400 includes all the soft good and includes items 1,5,14,15,16,17.

8.2.6 Disassembly and assembly of the Regulator

1. Turn CONTROL KNOB and ADJUSTING SCREW (items 9 & 10) counter-clockwise and remove.
2. Unscrew Mouting Nut (Item 20) and Remove Regulator from the System.
3. Place CAP (Item 3) in vise with CAP (Item 7) facing down. Components will want to fall out of CAP (item 7) when removed, so unscrew and Remove CAP (Item 7) out the bottom.
4. Remove from CAP (Item 7) and maintain order since they will need to be installed in reverse order. Remove SPRING GUIDE (Item 6), SPRING (Item 13), 2nd BEARING PLATE (Item 11), BEARING (Item 12), 1st BEARING PLATE (Item 11) and finally the SPRING GUIDE (Item 8)

5. With CAP (Item 3) still in Vise, Remove BODY (Item 2) with Strap Wrench and set aside.
6. Remove from CAP (Item 3) and maintain order since they will need to be installed in reverse order. Remove SEAL and STOP RING (Item 17 & 19), Remove VENT SEAT (Item 5), Remove SEAL (Item 15), Remove PISTON & SEAL (Item 4 & 14).
7. Remove POPPET ASSY & SEAL (Item 1 &16) from BODY (Item 2)

The above steps provide the disassembly procedures. To reassemble, simply reverse these procedures.

- Torque POPPET ASSY & SEAL (Item 1 &16) to BODY (Item 2) @ 10 to 20 ft. lbs.
- When reassembling, pack SEAL (Item 14) on PISTON (Item 4) heavily with Cristo-lube.
- Torque CAP (Item 3) to BODY (Item 2) @ 10 to 20 ft. lbs. using a Strap Wrench or by Hand.
- Use ample Slick 50 EP Grease or Equivalent on the bearings. Silicone spray can be used to coat and preserve parts.
- Torque CAP (Item 7) to CAP (item 3) @ about 20 ft. lbs.

8.2.8 Relief Valve

Check the operation of the vent valve by pressurizing the system until the vent begins to relieve the pressure. Decrease the pressure to stop the venting action, valve should stop bubble tight. If the relief valve does not operate correctly remove and disassemble, inspect. Replace any defective parts or clean, lubricate and reassemble.

To disassemble the relief valve, remove valve from system. In the output side of the valve there is a set screw, remove it. There is a second set screw under the first screw. The second set screw is the actual adjustment for the set point. The first screw is a locking screw that locks the adjusting screw at the set point.

There is another set screw at the other end of the valve, removing this allows the valve to be completely disassembled. When taking the valve apart be sure to lay the parts out in the order in which they were removed to facilitate assembly. Reverse the order to assemble. Pressurize the valve to check the setting of the valve. Remove the pressure and adjust as necessary to set the pressure. Turning the screw clockwise increases the pressure at which the valve will relieve.

8.2.9 LP Input check Valve

These are repairable. The Maintenance Kit is available from Amron and contains Viton seat and spring. When checking for leaks, be sure to check valve body to end of fitting. During test, insure that the valve is not leaking by pressurizing the HP section and check the LP input for air leaking out of the input.

8.2.10 Diver's Pressure Gauge

Same as HP pressure gauges.

8.2.11 Diver's Output Valves

1/4 turn ball-valves, to test, pressurize the input and turn the valves off, check that no air is leaking past the valve. The valves are repairable. They use Teflon seats which can be replaced. A maintenance kit is available from Amron. To replace, remove valve from system. Remove end pieces from valve, remove valve stem packing nut and remove stem. Teflon ball seal and stem packing can now be removed and replaced. To assemble, reverse the process.

8.3 Depth Monitoring**8.3.1 Pneumo Valves**

Pneumo Valves are repairable. Remove stem by removing handle and stem packing nut. Unscrew stem. Inspect stem, stem screw threads, valve body screw threads, brass and Teflon packing washer, and stem seat (KEL-F). Repair kits are available and include a complete stem assembly. Lubricate stem screw threads with Christolube grease, install stem assembly and permanently tighten packing nut.

8.3.2 Pneumo Gauges

Pneumo gauges are not field repairable nor are there any adjustments which can be made in the field. Check to make sure the blow-out plugs are in place. Calibrate every 6 months. Check the zero position of the gauge; a displaced zero is evidence of a gauge that has been subjected to over-pressurization.

Note: Check the gauge before using. If there is any question about the gauges integrity, have the gauge calibrated. Normal variations in zero are caused by variations in barometric pressure or changes in altitude. These variations normally will not exceed 10 feet.

8.4 Communicator Check Procedures

The following are a series of step-by-step procedures to perform a functional check of your AMCOM III 2830A communicator using only a headset. These steps check all communication functions in both 2-Wire and Full Duplex (4-Wire) mode. If the communicator checks out using these procedures, then any communication problems are probably located somewhere else in the system setup.

8.4.1 Full Duplex (4-Wire) Check

This procedure checks the communicator functions in the Full Duplex (4-Wire) mode.

1. Set all volume controls to the mid-scale (halfway) position.
2. Turn the SPEAKER SWITCH off to avoid acoustic feedback.
3. Turn on the communicator and verify the BATTERY CONDITION INDICATOR is on or blinking. If the LED does not come on at all, then replace or recharge the battery. If that does not resolve the problem, then go to the troubleshooting section to determine the cause.
4. Identify the microphone and headset leads. When using an Amron headset, the microphone is the red banana plug and the headset is the black banana plug.
5. Plug the microphone lead into the TENDER MICROPHONE (red) jack and the headset lead into the TENDER HEADSET (black) jack.
6. Don the headset and talk into the microphone. You should be able to hear yourself in the headset. Adjust the DIVER TO TENDER VOLUME control and verify the level can be adjusted to a comfortable level.
7. Move the headset microphone lead to the DIVER MICROPHONE (red) jack. Talk into the microphone. You should be able to hear yourself in the headset. Adjust the DIVER TO TENDER VOLUME control and verify that the level can be adjusted to a comfortable level.
8. Move the headset lead to the DIVER EARPHONE (black) jack. Talk into the microphone. You should be able to hear yourself in the headset.

This completes the check of the Full Duplex (4-Wire) function of the communicator. If at any point in the test you were not able to hear yourself in the headset as indicated by the test, refer to the troubleshooting section to determine the cause.

8.4.2 2-Wire Check

This procedure checks the communicator functions in the 2-Wire mode.

1. Set all the volume controls to the mid-scale (halfway) position.
2. Turn the SPEAKER SWITCH off to avoid acoustic feedback.
3. Turn on the communicator and verify the BATTERY CONDITION INDICATOR is on or blinking. If the LED does not come on at all, then replace or recharge the battery. If that does not resolve the problem, then go to the troubleshooting section to determine the cause.
4. Identify the microphone and headset leads. When using an Amron headset, the microphone is the red banana plug and the headset is the black banana plug.

5. Plug the microphone lead into the TENDER HEADSET (black) jack and the headset lead into the DIVER MICROPHONE (red) jack.
6. Don the headset. Talk into the microphone while pressing the PUSH-TO-TALK BUTTON. You should be able to hear yourself in the headset. Adjust the TENDER TO DIVER VOLUME control and verify that the level can be adjusted to a comfortable level.
7. Unplug the microphone lead. Turn on the SPEAKER SWITCH. Press the PUSH-TO-TALK BUTTON while speaking into the PANEL SPEAKER. You should be able to hear yourself in the headset. Adjust the TENDER TO DIVER VOLUME if necessary and verify that the level can be adjusted to a comfortable level.
8. Plug the microphone lead into the TENDER HEADSET (black) jack. Short the PUSH-TO-TALK JACK (yellow) with a short piece of wire. Talk into the microphone and verify that you hear yourself in the headset. Remove the short. Turn off the SPEAKER SWITCH.
9. Move the microphone lead to the DIVER MICROPHONE (red) jack and move the headset lead to the TENDER HEADSET jack.
10. Talk into the microphone and verify you can hear yourself in the headset. The PUSH-TO-TALK BUTTON should not be pressed. Adjust the DIVER TO TENDER VOLUME control and verify that the level can be adjusted to a comfortable level.

8.5 Communicator Troubleshooting

Most problems are usually simple issues that can often be found by careful inspection of the diver communicator, diving umbilical, and diver wiring. The following section will describe the troubleshooting procedure for several common issues. If these sections do not cover your particular issue, it is recommended that the diving umbilical be disconnected from the diver communicator and the check-out procedures in section 5.5 be conducted. If the diver communicator passes the check-out procedures then the issue is most likely in the umbilical connections, the umbilical itself, or the wiring of the diver's hat/helmet.

8.5.1 CONNECTION ISSUES

Most diver communicator problems are caused by bad connections. Making good connections will result in years of good communications. For longer life, all connections should be soldered and copper wire must be tinned. It is strongly suggested that dual banana plugs be used topside to provide convenient and secure connections.

All cable splices must be soldered. Splices should be staggered and covered with shrink tubing (preferably shrink tubing with an adhesive sealant) and a general splice cover to protect the connections. Potting the splices to create a reliable splice is preferred but not necessary to create a reliable splice.

8.5.2 LOW-BATTERY INDICATION

The BATTERY CONDITION INDICATOR indicates the battery level or state-of-charge by monitoring the battery voltage. The battery voltage can be measured independently using a voltmeter by measuring the voltage across the EXTERNAL BATTERY JACK. The voltage has to be 9 Volts or greater for the diver communicator to operate. It is recommended that the batteries be recharged for at least 10 hours if the measured voltage is less than 12 Volts (depending on the age of the battery and the surrounding temperature). If the BATTERY CONDITION INDICATOR indicates a low (blinking LED) or bad (off LED) after charging, then either the battery is bad and needs to be replaced or the charging circuit has malfunctioned.

8.5.3 UNIT NOT OPERATING

The most common reason that a diver communicator appears to be dead when the POWER SWITCH and SPEAKER SWITCH are turned on is a bad or loose battery. Check the battery per section 8.5.2. If the battery is good, then disconnect any diving umbilical and perform the communicator check out procedure per section 5.4.

If the battery and battery connections appear good and the communicator fails the check-out procedure, then remove the screws holding the front panel. Lift the front panel up carefully as the panel components are connected to a Printed Circuit Assembly (PCA) by a wire harness. Verify that the connectors on the PCA are firmly seated. Check that the wire harnesses are soldered to the various connectors, controls, and speaker. There should be no loose wires in the system. Remove the fuse from the PCA. It is marked FH1 and is a cylindrical component. Verify that the fuse is good by checking the continuity with a multi-meter. If the fuse is open, replace with the same type: 3.15 Amp, 250V, Fast Acting. Close the front panel; re-install the screws and re-test the communicator. If the communicator still appears dead, contact Amron for further assistance.

8.5.4 LOW VOLUME

Check the volume control settings and adjust if necessary. Check the diver connections and verify that the diver and tender are connected as intended. Verify the wires and connectors are clean and tight. Check the BATTERY CONDITION INDICATOR and test the battery per section 8.5.2 if necessary. If the problem persists, disconnect the diver umbilical and perform the communicator check out procedure per section 8.4. If the communicator fails the check-out procedure, contact Amron for further assistance.

If the communicator checks out, then the problem is likely in either the diver umbilical communication cable, the wiring of the diving hat/helmet, or the diver's microphone/earphone.

8.5.5 GARBLED VOICE TO THE DIVER

The TENDER TO DIVER VOLUME control is set too high. Reduce this control until the voice signal clears. If this does not solve the problem, check the diver's earphone for corrosion or other defect. Replace if necessary. If the tender is using a headset, remove the headset and communicate to the diver by pressing the PUSH-TO-TALK BUTTON and talking into the PANEL SPEAKER. If this solves the problem then the tender headset may be wet or defective. If the tender is using the PANEL SPEAKER to talk to the diver, check the speaker for any accumulated water. Drain the speaker if necessary. If these steps do not solve the problem then disconnect the diver umbilical and perform the communicator check out procedure per section 8.4. If the communicator fails the check-out procedure, contact Amron for further assistance. If the communicator checks out, then the problem is likely in the diver umbilical communication cable. If possible, substitute a known good cable to verify.

8.5.6 GARBLED VOICE TO THE TENDER

The DIVER TO TENDER VOLUME control is set too high. Reduce this control until the voice signal clears. If this does not solve the problem, check the diver's microphone for corrosion or other defect. Replace if necessary. If the tender is using a headset, remove the headset and listen to the diver using the PANEL SPEAKER. If this solves the problem then the tender headset may be wet or defective. If the tender is using the PANEL SPEAKER to talk to the diver, check the speaker for any accumulated water. Drain the speaker if necessary. If these steps have not solved the problem, then disconnect the diver umbilical and perform the communicator check out procedure per section 8.4. If the communicator fails the check-out procedure, contact Amron for further assistance. If the communicator checks out, then the problem is likely in the diver umbilical communication cable. If possible, substitute a known good cable to verify.

8.5.7 DIVER CUTS OFF

This is usually caused by an intermittent connection between either the umbilical and the diver communicator or the umbilical and the diver's hat/helmet. The intermittent connection could also be inside the diver's hat/helmet. Check all connections to verify that they are clean and tight. If the problem continues, substitute the communication cable with a known good cable. If this solves the issue, then the communication cable in the original umbilical is damaged and needs to be replaced or repaired. If none of these solutions fixes the problem, contact Amron for further assistance.

8.5.8 FEEDBACK - FULL DUPLEX (4-WIRE) MODE

There are two forms of feedback that can affect the communicator: acoustic feedback or cable crosstalk. Acoustic feedback occurs when an active microphone is close enough to pick up and amplify the signal from a speaker or earphone. The required distance between the microphone and speaker/earphone is dependent on

the volume setting and the amount of acoustic isolation. For example, a tender headset left sitting on a work table may cause acoustic feedback. When the tender dons the headset at the same volume level, the acoustic feedback will no longer occur. The tender's head provides acoustic isolation between the microphone and earphone of the headset. The same is true for the diver's microphone and earphone.

To troubleshoot acoustic feedback issues first determine the source. One way to quickly determine the source of the acoustic feedback is to cover each active microphone with your hand, one at a time. Another method is to adjust the volume controls one at a time. The volume control that stops the feedback indicates the source. For example, if the TENDER TO DIVER VOLUME control stops the feedback, then the problem is likely in the diver's hat/helmet. Common sources are feedback between the tender's headset microphone and the PANEL SPEAKER of the communicator. If the tender wants to operate with the headset and leave the PANEL SPEAKER on, Amron recommends the tender move away from the communicator by using the Amron Model 2822-28 Remote Walk-and-Talk Module. This module provides an "extension" cord for the tender headset.

Crosstalk is caused by signal leakage between the microphone and earphone wires in the umbilical cable. In a good cable with all the wires open (not connected) the resistance between any two wires should be greater than 10 Meg-Ohms. Over time, the cable can be damaged and this resistance drops to the point that crosstalk can occur. When this occurs, the communication cable in the umbilical should be replaced. For a temporary solution, you can try swapping the position of the diver earphone wires on the DIVER EARPHONE jack. If you are using a banana plug, simply unplug the diver earphone and rotate by 180 degrees before reconnecting. If this does not solve the problem and the umbilical cannot be immediately replaced, then operate in 2-Wire mode until a replacement umbilical can be used. Amron strongly recommends the use of the Amron CC1 communication cable. It has been specially designed for clear communications and long service life.

8.5.9 PUSH-TO-TALK DOES NOT WORK

If used, check the connection to the hand-held microphone. A common issue is that the yellow banana plug is not properly seated in the PUSH-TO-TALK JACK. If the tender is using the PANEL SPEAKER as the microphone with the PUSH-TO-TALK BUTTON, make sure the SPEAKER SWITCH is turned on. If neither of these solves the problem, there could be a broken wire inside the diver communicator. Open the front panel and inspect. If that does not resolve the problem then contact Amron.

9. REFERENCE MATERIAL

9.1 Diving Log, U.S. Navy (Chart)

DIVING CHART - AIR							Date	
NAME OF DIVER 1			DIVING APPARATUS		TYPE DRESS		EGS (PSIG)	
NAME OF DIVER 2			DIVING APPARATUS		TYPE DRESS		EGS (PSIG)	
TENDERS (DIVER 1)				TENDERS (DIVER 2)				
LEFT SURFACE (LS)		AND DEPTH (fsw)		REACHED BOTTOM (RB)		AND DESCENT TIME		
LEFT BOTTOM (LB)		TOTAL BOTTOM TIME (TBT)		TABLE & SCHEDULE USED		TIME TO FIRST STOP		
REACHED SURFACE (RS)		TOTAL DECOMPRESSION TIME (TDT)		TOTAL TIME OF DIVE (TTD)		REPETITIVE GROUP		
DESCENT	ASCENT	DEPTH OF STOPS	DECOMPRESSION TIME		TIME			
			WATER	CHAMBER	WATER	CHAMBER		
	↑	10			L			
	↑	20			R			
	↑	30			L			
		40			R			
		50			L			
		60			R			
		70			L			
		80			R			
		90			L			
		100			R			
		110			L			
		120			R			
	↓	130			L			
PURPOSE OF DIVE					REMARKS			
DIVER'S CONDITION					DIVING SUPERVISOR			

9.2 Repetitive Dive Worksheet

REPETITIVE DIVE WORKSHEET

I. PREVIOUS DIVE:
 _____ minutes Standard Air Table
 _____ feet No-Decompression Table
 _____ repetitive group designation

II. SURFACE INTERVAL:
 _____ hours _____ minutes on surface.
 Repetitive group from I _____
 New repetitive group from surface _____
 Residual Nitrogen Timetable _____

III. RESIDUAL NITROGEN TIME:
 _____ feet (depth of repetitive dive)
 New repetitive group from II. _____
 Residual nitrogen time from _____
 Residual Nitrogen Timetable _____

IV. EQUIVALENT SINGLE DIVE TIME:
 _____ minutes, residual nitrogen time from III.
 + _____ minutes, actual bottom time of repetitive dive.
 = _____ minutes, equivalent single dive time.

V. DECOMPRESSION FOR REPETITIVE DIVE:
 _____ minutes, equivalent single dive time from IV.
 _____ feet, depth of repetitive dive
 Decompression from (check one):
 Standard Air Table No-Decompression Table
 Surface Table Using Oxygen Surface Table Using Air
 No decompression required

Decompression Stops: _____ feet _____ minutes
 _____ feet _____ minutes
 _____ feet _____ minutes
 _____ feet _____ minutes
 _____ feet _____ minutes

Scheduled used _____
 Repetitive group _____

9.3 No Decompression Limits

(Non-repetitive Dives Only) U.S. Navy Diving Manual (Air Decompression)

Depth FSW	Bottom Time
40	200
50	100
60	60
70	50
80	40
90	30
100	25
110	20
120	15
130	10
140	10
150	5
160	5
170	5
180	5
190	5

NOTE: OSHA Regulations Require: A decompression chamber capable of recompressing the diver at the surface to a minimum of 165 FSW (6 ATA) and shall be available at the dive location for: A) surface supplied air-diving to depths deeper than 100 FSW.

9.4 Gauge Pressure for Depth of Seawater & Fresh water

Gauge Pressure in PSI

Depth In	Feet of Fresh Water	Seawater
10	4.33	4.45
20	8.66	8.90
30	12.99	13.35
40	17.32	17.80
50	21.65	22.25
60	25.98	26.70
70	30.31	31.10
80	34.64	35.60
90	38.97	40.05
100	43.30	44.50
110	47.63	48.95
120	51.96	53.40
130	56.29	57.85
140	60.62	62.30
150	64.95	66.75
160	69.28	71.20
170	73.61	75.65
180	77.94	80.10
190	82.27	84.55
200	86.60	89.00

9.5 Equivalent Depths of Seawater & Freshwater

Depth	Equivalent Depth
Feet of Seawater	Feet of Fresh Water
10	10.30
20	20.30
30	30.90
40	41.20
50	51.50
60	61.80
70	72.10
80	82.40
90	92.70
100	103.00
110	113.30
120	123.60
130	133.90
140	144.20
150	154.50
160	164.80
170	175.10
180	185.40
190	195.70
200	206.00

10. DRAWINGS AND SCHEMATICS

The following drawings illustrate the electrical and mechanical details of the diver communication unit. The corresponding parts lists for each drawing are detailed in the parts lists section.

10.1 Parts Locator, Model 8330i-200 (Pneumo Front Panel)

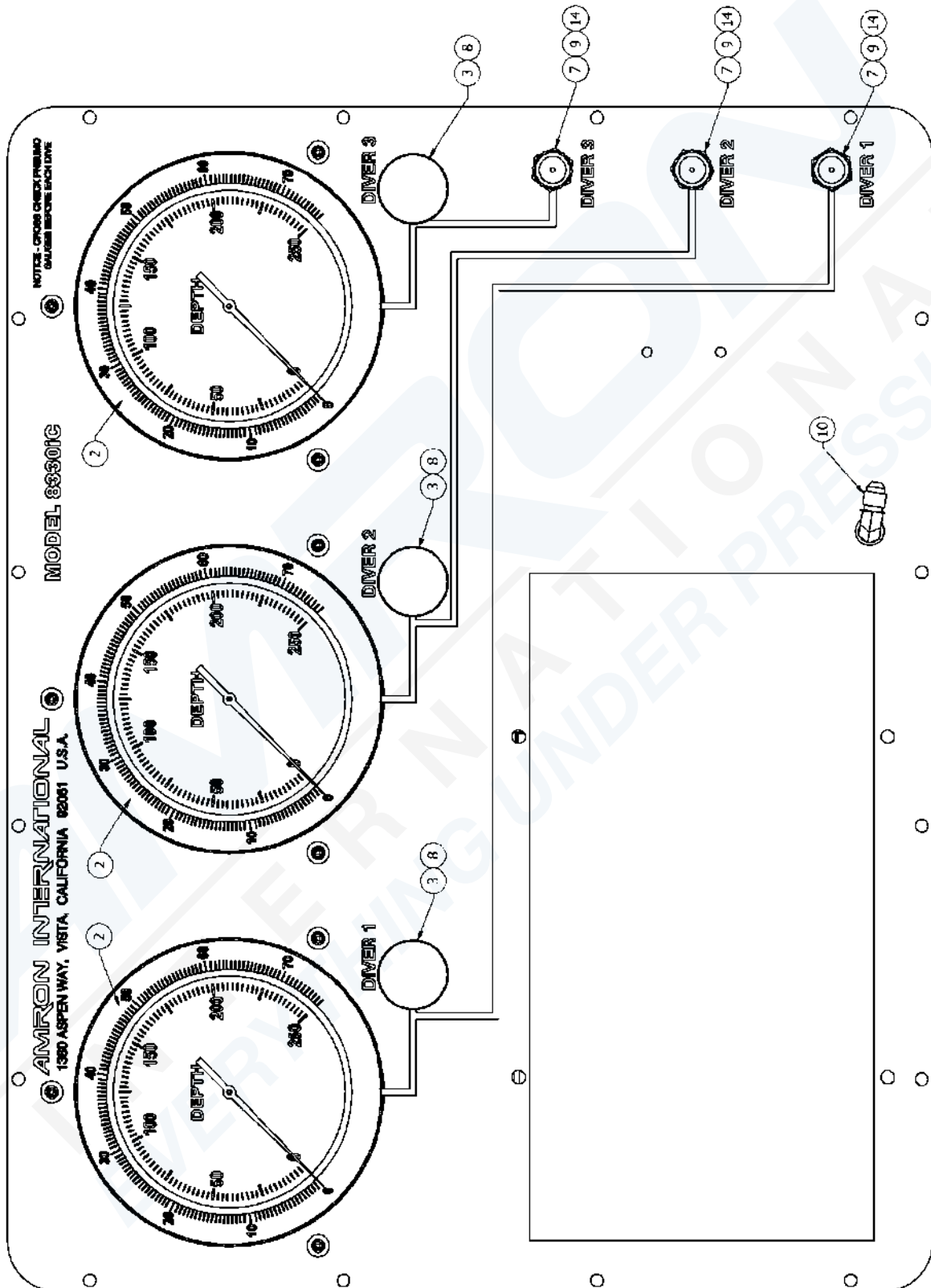

10.2 Parts Locator, Model 8330i-200 (Pneumo Back Panel)

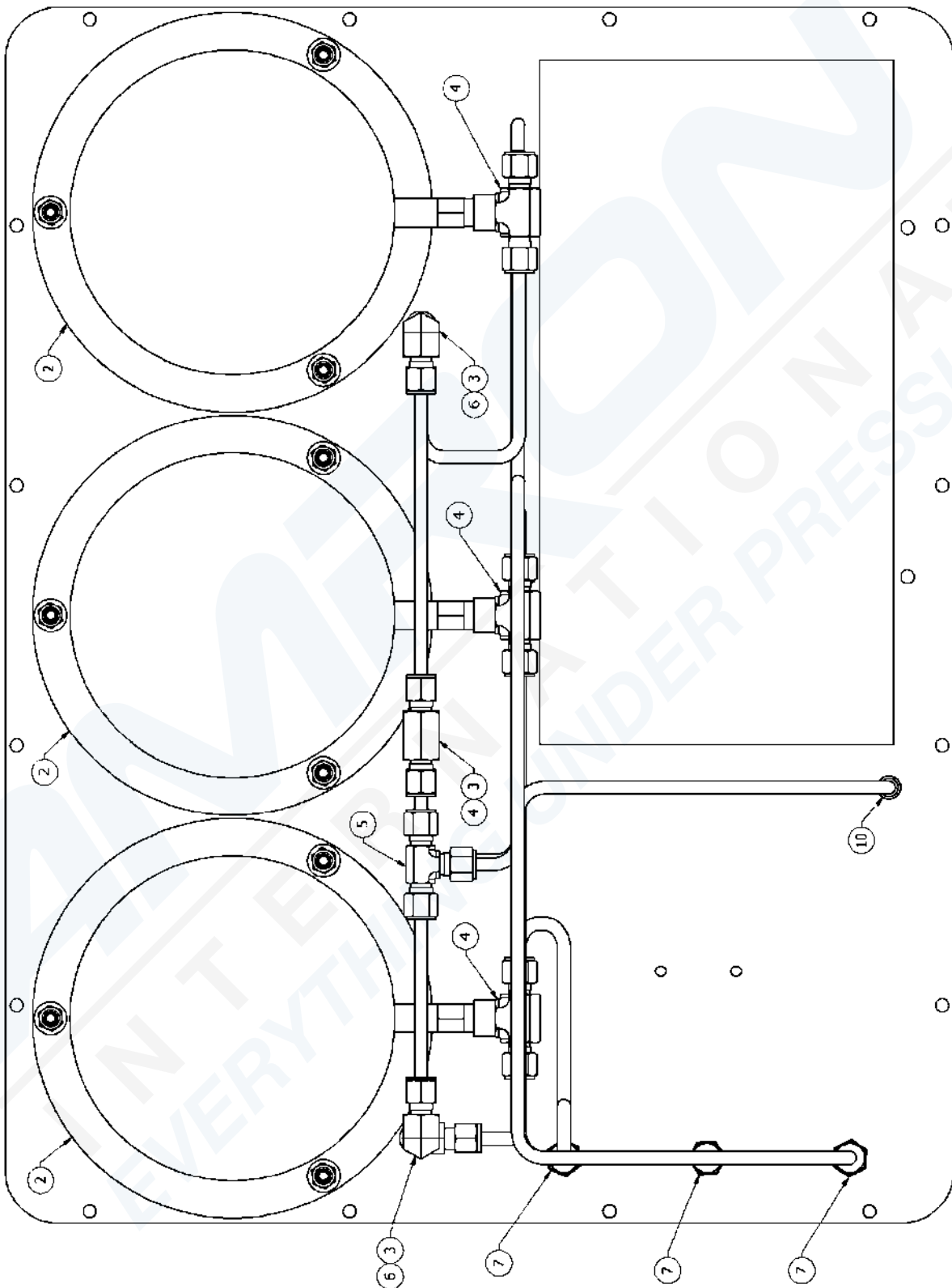

10.3 Parts Locator, Model 8330i-400 (Air Control Front Panel)

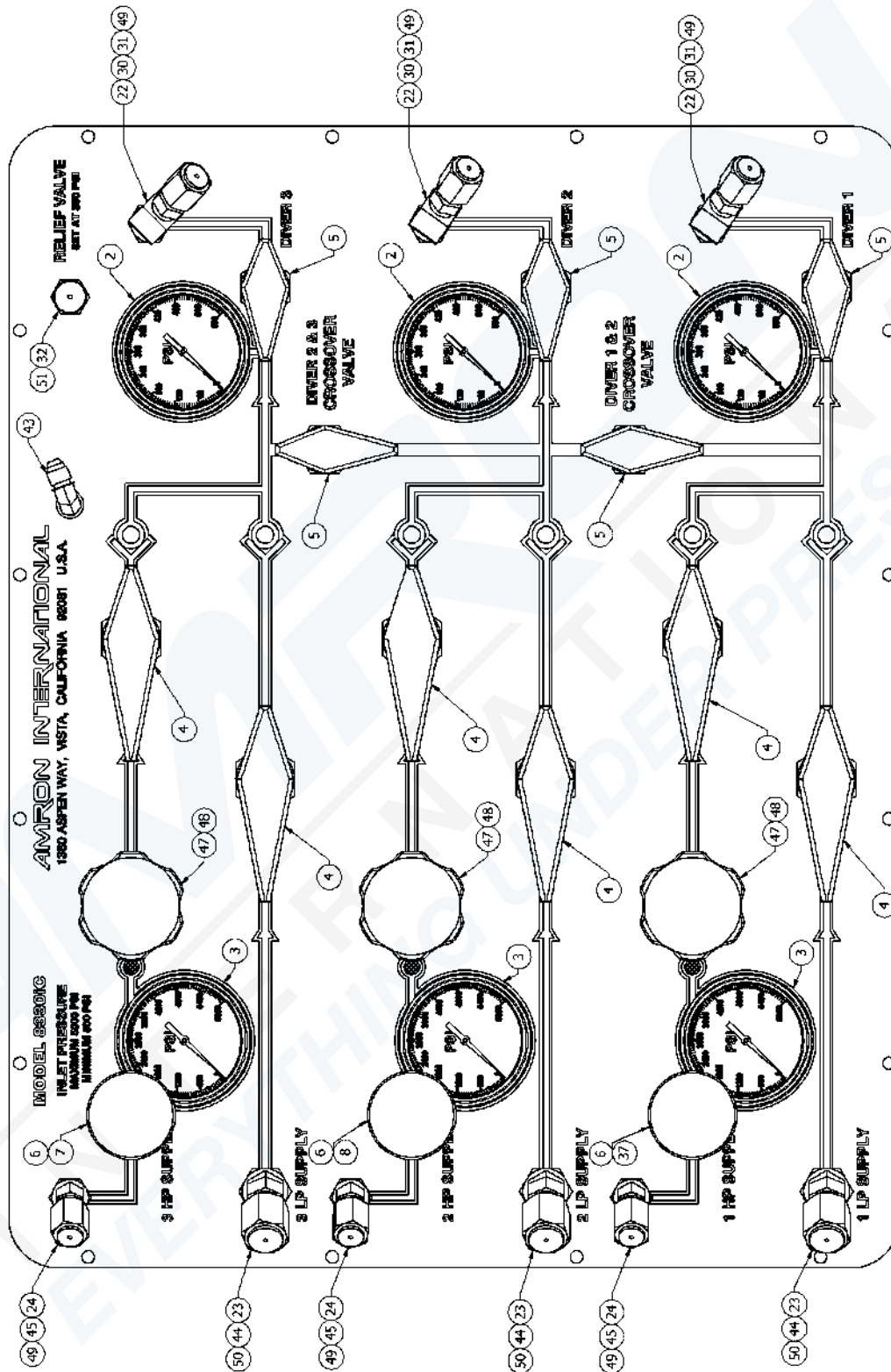

10.4 Parts Locator, Model 8330i-400 (Air Control Back Panel)

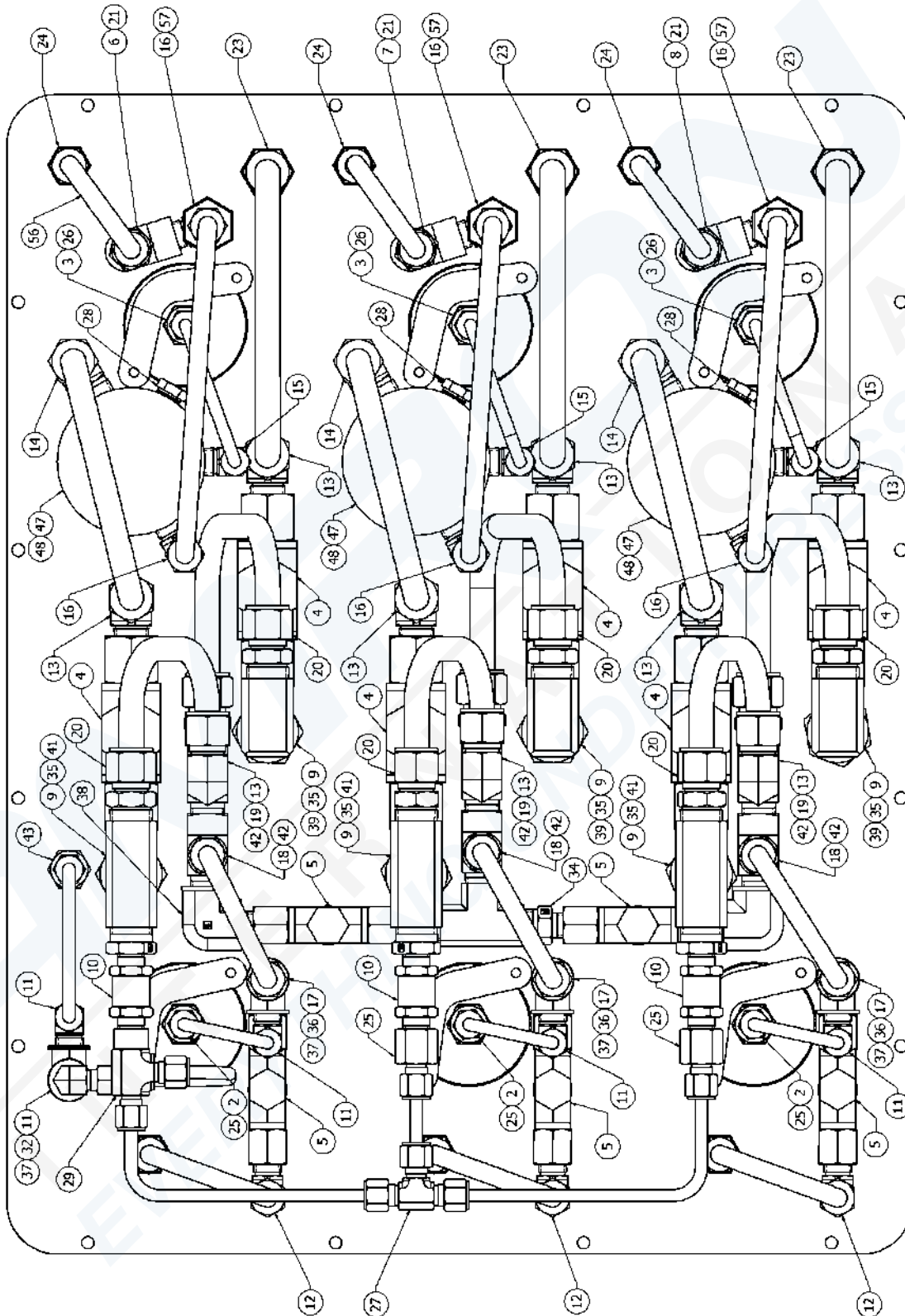

11. PARTS LISTS

The parts lists include both mechanical and electrical parts. The following information will be useful in interpreting data which is not self-explanatory.

REVISIONS

The parts lists in this manual are for the current model of diver communicator as of the printing date.

To Order Replacement Parts Contact:

Amron International, Inc.
1380 Aspen Way, Vista, California, 92081 U.S.A.
Telephone: (760) 208-6500 Fax: (760) 599-3857
Email: sales@amronintl.com
Web: www.amronintl.com

When ordering replacement parts, you should give as much information as possible to enable us to supply the correct part. This information should include the part number, description, reference designator, value, radio model number, and serial number. Failure to provide sufficient information may hinder our ability to fill your parts orders promptly and correctly.

11.1 Air Control System, Model 8330i

Reference	Part No.	Description
1	8330i-200	Pneumo Panel Assembly
2	8300-300	Case Assembly System
3	8330i-400	A/C Panel Assembly, 8330i
4	HP4FS16	16IN HP Whip NO4 JIC X NO4

11.2 Air System Control Model 8330iC-01

Reference	Part No.	Description
1	8330i-200	Pneumo Panel Assembly
2	8300-300	Case Assembly
3	8330i-400	A/C Panel Assembly, 8330i
4	HP4FS16	16IN HP Whip NO4 JIC X NO4
5	2830A-04	3-Diver Deluxe Communicator
6	2405-28	Hand Held Microphone

11.3 8330i-200 Pneumo Panel Assembly

Reference	Part No.	Description
2	25545-23B11-HDP	6in Pressure Gauge
3	4M4Z-V4AK-B-YEL	Needle Valve
4	OBZ-B-4-4-4	Female Brass Tee 1/4" T x 1/4" T x 1/4" NPT
5	JBZ-B-4-4-4	Union Tee 1/4" T
6	DBZ-B-4-4	Female Elbow 1/4" T x 1/4" FNPT
7	GH2BZ-B-4-4	Female Bulkhead
8	4 PANEL NUT	Panel Nut for Needle Valve
9	MA-742	O2 Fitting
10	WEBTX-B-4	Bulkhead Union
14	8200-016	Dust Cap Retainer
*	822091-B	Repair Kit for Needle Valve
N/S = Not Shown		
* = Repair Kit		

11.4 8330i-400 Air Control Panel Assembly, Model 8330i & 8330iC-01

Reference	Part No.	Description
2	71172520600	Gauge, 0-600 PSI w/Clamp
3	71172520600	Gauge, 0-6000 PSI w/Clamp
4	6F-B8LJ-BP	Ball Valve, 3/8" FNPT
5	4F-B6LJ-BP	Ball Valve, 1/4" FNPT
6	4F-V6AK-V-SS-KRY-LH	Valve, Angle 1/4" Fem Pipe S/S Kel-F
7	V6-HANDLE-BLUE	V6 Handle, Blue
8	V6-HANDLE-RED	V6 Handle, Red
9	8M-C8L-1-B	Check Valve, Brass, 3/8 MNPT, 1 PSI*
10	4M-C4L-1/3-B	Check Valve, S/S, 1/4 MNPT 1/3 PSI*
11	CBZ-B-4-4	Elbow, Male 1/4 x 1/4 Brass
12	CBZ-B-6-4	Elbow Male, Male 3/8 x 1/4 Brass
13	CBZ-B-8-6	Elbow, Male 1/2 x 3/8 Brass
14	CBZ-B-8-8	Elbow, Male 1/2 Brass
15	CBZ-SS-4-4	Elbow, Male 1/4 SS
16	CBZ-SS-6-4	Elbow, Male 3/8 x 1/4, SS
17	FBZ-B-6-4	Male, 3/8 x 1/4 Brass
18	FBZ-B-6-6	Male 3/8 Brass
19	FBZ-B-8-6	Male 1/2 x 3/8 Brass
20	FBZ-B-8-8	Male 1/2 Brass
21	FBZ-SS-6-4	Male 3/8 x 1/4
22	GH2BZ-B-6-4	Female Bulkhead, Brass
23	GH2BZ-B-8-6	Female Bulkhead, Brass
24	GH2BZ-SS-6-4	Female Bulkhead, SS
25	GBZ-B-4-4	Connector, Female 1/4 Brass
26	GBZ-SS-4-4	Connector, Female 1/4 SS
27	JBZ-B-4-4-4	Union Tee, 1/4
28	HP-B-1/4	Plug, Hex 1/4
29	MBZ-B-4-4-4	Female Run Tee Brass 1/4
30	MA-742	Adapter, 02 x 1/4 MNPT Brass Chrome
31	MPF-222	Street Elbow, 45 Deg
32	4CPA2-150-B	Valve, Relief Adjustable*
33	209P-8-4	Reducer
34	216P-6-4	Reducer
35	1202P-8-6	Street Elbow
36	1204P-4	Elbow, Brass, NPT 1/4
37	V6-HANDLE-GREEN	V6 Handle, Green
38	1202P-6-4	Street Elbow 3/8 FNPT x 1/4
39	2200P-8-8	Female Elbow, 1/2
40	2203P-6	Union Tee, 3/8 FNPT
41	2203P-8	Union Tee, 1/2 FNPT
42	2225P-6	Street Tee, 3/8
43	WEBTX-B-4	Bulkhead Union
44	VTX-B-8	Male Elbow, 45 Deg. Brass

Reference	Part No.	Description
45	VTX-SS-6	Male Elbow, 45 Deg. SS
47	873-400-NV	Regulator, High Flow
48	952	Regulator Nut
49	8200-016	#6 Dust Cap
50	8200-018	#8 Dust Cap
51	8600-014	Diffuser, Vent Cap
57	6Z-F6L-50-SS	Filter, 50 Micron*
*	822188-SS	Repair Kit, for P/N 4FV6AKVSS-B2500-
*	802065-4	Repair Kit, for P/N B6LJ
*	802045	Repair Kit, for P/N 4M-C4L-1/3-B
*	KIT-C8-1-V	Repair Kit, for P/N 8M-C8L-1-B
*	KIT-F6-50-V	Repair Kit, for P/N 6Z-F6L-50-SS
*	979-400	Repair Kit, for P/N 873-400-NV
N/S = Not		
* = Repair		

11.5 Regulator, Pressure Reducing

Reference	Part No.	Description
1	895	Poppet Assy
2	893	Body
3	879	Cap
4	744	Piston
5	1035-1	Seat (Non-Vented)
6	849	Spring Guide
7	903	Cap
8	410	Spring Guide
9	378-2	Adjusting Screw
10	379-30	Knob
11	379-37	Bearing Plate
12	379-38	Bearing
13	379-5	Spring
14	876-24	Seal
15	876-15	Seal
16	876-16	Seal
17	876-27	Seal
18	944	Piston Housing
19	945	Stop Ring
20	952	Mount Nut - optional
21	979-400	Repair Kit, includes Soft Goods Kit (* & **)

11.6 2830A-04 Front Panel Assembly

Reference	Part No.	Description
2	PBSWITCH	SWITCH PUSH BUTTON SEALED N.O
3	7580K6	SWITCH TOGGLE SPST
33	757-3522	SWITCH TOGGLE DPST ON-ON
5	1498-102	JACK, BANANA RED
6	1498-103	JACK, BANANA BLACK
7	1498-107	JACK, BANANA YELLOW
8	5168	SEAL HALF BOOT TOGGLE GREY
9	105-0602-001	JACK, TIP RED
10	105-0603-001	JACK, TIP BLACK
11	ME161-2003	JACK, PHONO W/NYL WSHRS NKL/BLK
14	14002B	5-WAY BINDING POST (BLACK)
15	14002R	5-WAY BINDING POST (RED)
18	SA818	SPEAKER 8 OHM 15 WATT
4	P16NP-10K	POTENTIOMETER 10K OHM W/KNOB
16	LEDHOLDER-BLK.25	MOUNTING CLIP FOR 5MM LED
17	LT2462-24-D51	LED, BI-COLOR RED/GREEN

11.7 Recommended Spare Parts

++Reference	Part No.	Description
N/S	802045	Repair Kit, for P/N 4M-C4L-1/3-SS
N/S	802065-4	Repair Kit, for P/N B6LJ
N/S	822188-SS	Repair Kit, for P/N 4FV6AKVSS-B2500-KRY, 4FV6AKVSS-R2500-KRY
N/S	KIT-F6-50-V	Repair Kit, for P/N 6Z-F6L-50-SS
N/S	KIT-C8-1-V	Repair Kit, for P/N 8M-C8L-1-B
N/S	822091-B	Repair Kit for P/N 4M4Z-V4AK-B-YEL
N/S	979-400	Repair Kit, includes Soft Goods Kit (* & **)
N/S	72HP	Hose Assembly, 72" HP (5000)
14	14002B	Binding Post, Black
15	14002R	Binding Post, Red
5	1498-102	Jack, Banana Red
6	1498-103	Jack, Banana Black
7	1498-107	Jack, Banana Yellow
8	5168	Switch, Seal Toggle Shaft
3	7580K6	Switch, Toggle SPST
2	PBSWITCH	Switch, Push Button SPST (mom)
N/S	2890-05	Battery, Rechargeable 12 Volt, 7 Ah
N/S	14001B	Plug, Dual Banana Black
N/S	14001Y	Plug, Dual Banana Yellow
N/S	14001R	Plug, Dual Banana Red
N/S	0034.6019	Fuse, Communicator Amplifier Card
N/S	28XXA-FS- 02	Field Spares Kit
N/S	570-1008-30	Amplifier Card Assembly
N/S	2405-28	Hand Held Microphone P-T-T
N/S	2830A-400	Radio Front Panel Assembly w/ Harness

13. LIMITED WARRANTY AND SERVICE POLICY

Amron International, Inc.

LIMITED WARRANTY & SERVICE POLICY

LIMITED WARRANTY

AMRON INTERNATIONAL, INC., (Amron) warrants that its manufactured products are free from defects in material and workmanship under normal use and service for a period of one year from date of shipment as described in Amron's literature covering this product. Oxygen Treatment Hoods and accessories are excluded and limited to 90 days. Amron's obligation under this warranty is limited to the repair or replacement, at Amron's option, of defective material. This warranty shall not cover defects which are the result of misuse, negligence, accident, repair or alterations.

SERVICE POLICY

For technical assistance or to request a repair, please complete one of the following:

- *Amron Communicator Repair* : <https://www.amronintl.com/communicator-repair-form>
- *Repair Request* (all other products): <https://www.amronintl.com/repair-form>
- Call (760) 208-6500, Monday – Friday, 8 a.m. to 5 p.m. PST.

Both MODEL NO. and SERIAL NO. are required fields to be entered on the *Amron Communicator Repair Request* form and can be found on the products identification label as shown below.

“Sample” Product Identification Label

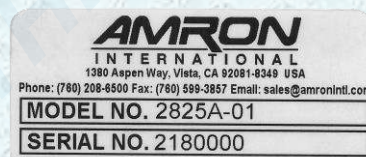

Do not return any product without obtaining a RMR (Return Materials Request). Detailed return instructions will be provided at the time of request.

1380 Aspen Way, Vista California 92081-8349 U.S.A
Phone: (760) 208-6500 Fax (760) 599-3857
Email: sales@amronintl.com Web: www.amronintl.com