

PRODUCT DETAILS:

Max Height Filled - 1.3m
Max Height Empty - 1.5m
Max Diameter Filled - 0.9m
Product Weight - 3kg Approx

250kg Air Lift Bag Component List			
Item Number	Component Title	Component Description	QTY Per Unit
1	Canopy	Heavy Duty PVC coated Polyester Base Cloth	1
2	Masterlink Assembly	Masterlink Assembly	1
3	Shackles	Galvanised Green Screw Pin Shackles	1
4	Main Strops	Polyester Sling Webbing fitted	4
5	Shackles	Galvanised Green Screw Pin Shackle	4
6	Dump Valve	2" Bottom Operated Dump valve	1
7	Dump Valve Lanyard	3mm Cord complete with Tinsley Ring	1
8	Inverter Point	Webbing Patch for Inverter Line Attachment	1
9	De-Tangler	Unique De-Tangler verifies Rigging in Zero Visibility	1

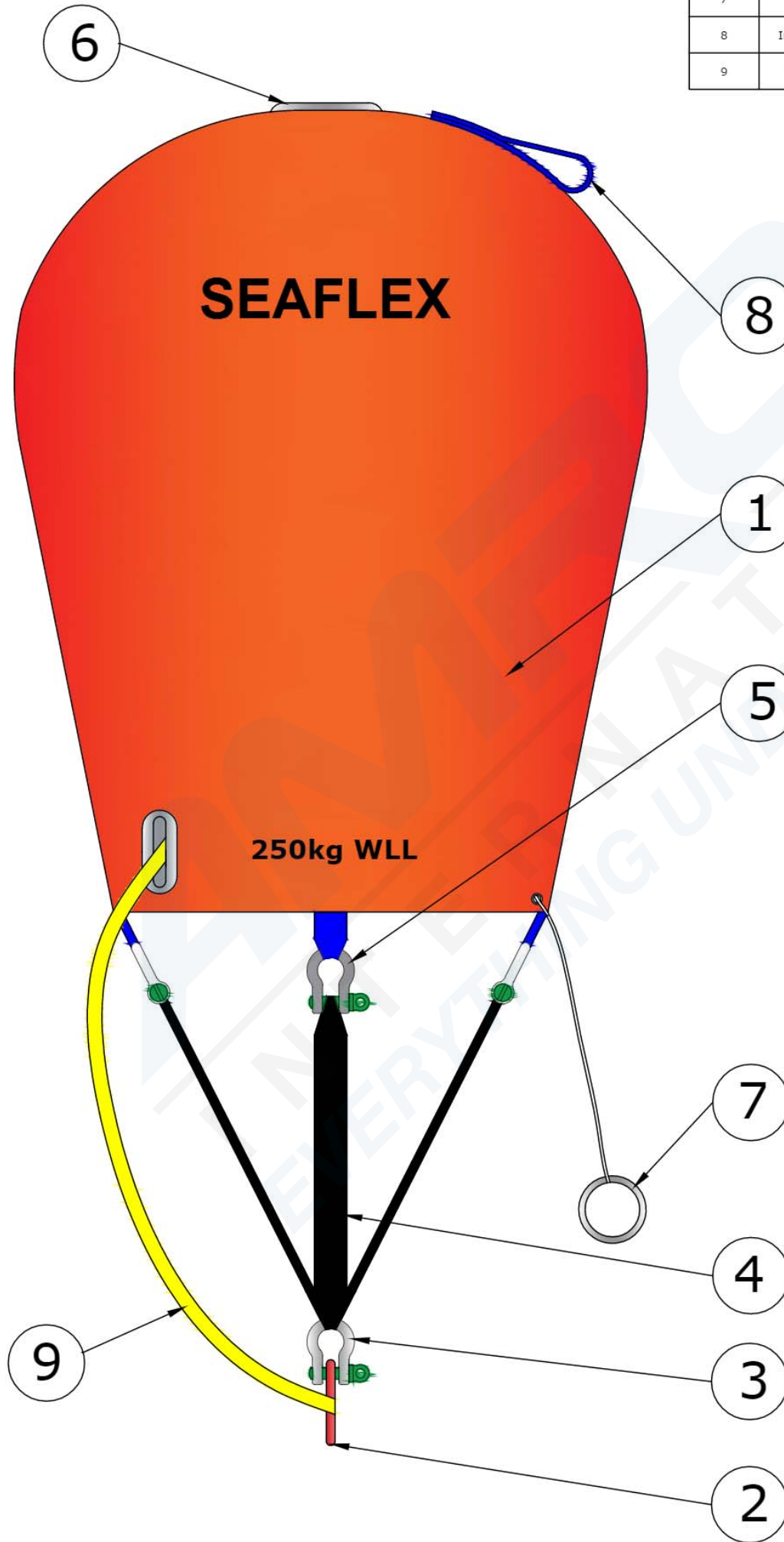

The Intellectual Property of this drawing belongs wholly to Unique Seaflex Ltd, and may not be copied or republished without permission. Contents are accurate at time of issue, but may be subject to change without notice

 Unique SEAFLEX A Unique Maritime Group Company	
SEAVIEW ROAD COWES ISLE OF WIGHT ENGLAND PO31 7US TEL: +44 1983 290 525 www.uniquegroup.com	
DRAWING TITLE 250kg Air Lift Bag Specification Sheet	SCALE N.T.S @ A3
PROJECT NUMBER Air Lift Bag (ALB)	DRAWN GJP
DRAWING No. 250kg - ALB - SS	REVISION 01

Certificate of Test

1074

Item under Test 250kg Seaflex Air Lift Bag (ALB)

Date of Test 25th June 2007

Test load cell Type STA-2000 S/No. 9597403

Instrumentation Pico ADC11

Sample rate 5MHz

Results Peak force measured at 1786 Kg

Type Test In accordance with IMCA D016

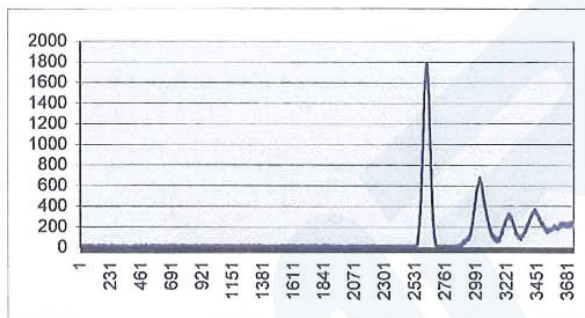

All test loads applied are traceable to national standards

R. Cundall
Test engineer

Company reg. No.: 03112726 VAT reg. No. 861 3444 31
Reg. Office: 3, Garfield Road, Ryde, Isle of Wight, PO33 2PS
Directors: R. Cundall, L. Varney, P. Wardrop



CERTIFICATE NUMBER

12-LD890111-PDA

DATE

22 August 2012

ABS TECHNICAL OFFICE

London Engineering Department

CERTIFICATE OF DESIGN ASSESSMENT

This is to Certify that a representative of this Bureau did, at the request of
SEAFLEX LTD.

assess design plans and data for the below listed product. This assessment is a representation by the Bureau as to the degree of compliance the design exhibits with applicable sections of the Rules. This assessment does not waive unit certification or classification procedures required by ABS Rules for products to be installed in ABS classed vessels or facilities. This certificate, by itself, does not reflect that the product is Type Approved. The scope and limitations of this assessment are detailed on the pages attached to this certificate.

PRODUCT: **Air Lift Bag**

MODEL: **25kg ALB, 50kg ALB, 100kg ALB, 250kg ALB, 500kg ALB, 1t ALB, 2t ALB, 3t ALB, 5t ALB, 10t ALB, 20t ALB and 35t ALB**

This Product Design Assessment (PDA) Certificate 12-LD890111-PDA, dated 22/Aug/2012 remains valid until 21/Aug/2017 or until the Rules or specifications used in the assessment are revised (whichever occurs first).

This PDA is intended for a product to be installed on an ABS classed vessel, MODU or facility which is in existence or under contract for construction on the date of the ABS Rules or specifications used to evaluate the Product.

Use of the Product on an ABS classed vessel, MODU or facility which is contracted after the validity date of the ABS Rules and specifications used to evaluate the Product, will require re-evaluation of the PDA.

Use of the Product for non ABS classed vessels, MODUs or facilities is to be to an agreement between the manufacturer and intended client.

AMERICAN BUREAU OF SHIPPING

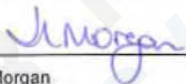
John L. Morgan
Engineer

NOTE: This certificate evidences compliance with one or more of the Rules, Guides, standards or other criteria of ABS or a statutory, industrial or manufacturer's standard. It is issued solely for the use of ABS, its committees, its clients or other authorized entities. Any significant changes to the abovementioned product without approval from ABS will result in this certificate becoming null and void. This certificate is governed by the terms and conditions as contained in ABS Rules 1-1-A3/3.9 Terms and Conditions of the Request for Product Type Approval and Agreement (2010).

A02580110