

ID07 Hydraulic Impact Drill

49228 User Manual 2/2022 Ver. 5

<p>DECLARATION OF CONFORMITY ÜBEREINSTIMMUNGS-ERKLÄRUNG DECLARATION DE CONFORMITE CEE DECLARACION DE CONFORMIDAD DICHIARAZIONE DI CONFORMITA</p>	<p>STANLEY® Infrastructure CE</p>																											
<p>I, the undersigned: Ich, der Unterzeichnende: Je soussigné: El abajo firmante: Io sottoscritto:</p>	<div style="border: 1px solid black; padding: 5px; display: inline-block;"> <p>Gunishetty, Shravan</p> </div> <p style="font-size: small; margin-top: 5px;">Surname and First names/Familiennamen und Vornamen/Nom et prénom/Nombre y apellido/Cognome e nome</p>																											
<p>hereby declare that the equipment specified hereunder: bestätige hiermit, daß erklaren Produkt genannten Werk oder Gerät: déclare que l'équipement visé ci-dessous: Por la presente declaro que el equipo se especifica a continuación: Dichiaro che le apparecchiature specificate di seguito:</p>																												
<p>1. Category: Kategorie: Catégorie: Categoria:</p>	<p>Hydraulic Hand-Held Impact Drill</p>																											
<p>2. Make/Marke/Marque/Marca/Marca</p>	<p>STANLEY</p>																											
<p>3. Type/Typ/Type/Tipo/Tipo:</p>	<p>ID0781501, ID0782001, ID0792001</p>																											
<p>4. Serial number of equipment: Seriennummer des Geräts: Numéro de série de l'équipement: Numero de serie del equipo: Matricola dell'attrezzatura:</p>	<div style="border: 1px solid black; padding: 5px; display: inline-block;"> <p>All</p> </div>																											
<p>Has been manufactured in conformity with Wurde hergestellt in Übereinstimmung mit Est fabriqué conformément Ha sido fabricado de acuerdo con E' stata costruita in conformità con</p>																												
<table border="1" style="width: 100%; border-collapse: collapse; font-size: small;"> <thead> <tr> <th style="width: 30%;">Directive/Standards Richtlinie/Standards Directives/Normes Directriz/Los Normas Direttiva/Norme</th> <th style="width: 30%;">No. Nr Numéro No n.</th> <th style="width: 40%;">Approved body Prüfung durch Organisme agréé Aprobado Collaudato</th> </tr> </thead> <tbody> <tr> <td>EN ISO</td> <td>4413:2010</td> <td>Self</td> </tr> <tr> <td>EN ISO</td> <td>12100:2010</td> <td>Self</td> </tr> <tr> <td>EN ISO</td> <td>28927-2:2009 +A1:2017</td> <td>Self</td> </tr> <tr> <td>EN ISO</td> <td>3744:2010</td> <td>Self</td> </tr> <tr> <td>EN ISO</td> <td>11148-6:2012, Cl. 5.4</td> <td>Self</td> </tr> <tr> <td>EN ISO</td> <td>11148-6:2012, Cl. 5.5</td> <td>Self</td> </tr> <tr> <td>EN ISO</td> <td>13732-1:2008</td> <td>Self</td> </tr> <tr> <td>Machinery Directive</td> <td>2006/42/EC:2006</td> <td>Self</td> </tr> </tbody> </table>		Directive/Standards Richtlinie/Standards Directives/Normes Directriz/Los Normas Direttiva/Norme	No. Nr Numéro No n.	Approved body Prüfung durch Organisme agréé Aprobado Collaudato	EN ISO	4413:2010	Self	EN ISO	12100:2010	Self	EN ISO	28927-2:2009 +A1:2017	Self	EN ISO	3744:2010	Self	EN ISO	11148-6:2012, Cl. 5.4	Self	EN ISO	11148-6:2012, Cl. 5.5	Self	EN ISO	13732-1:2008	Self	Machinery Directive	2006/42/EC:2006	Self
Directive/Standards Richtlinie/Standards Directives/Normes Directriz/Los Normas Direttiva/Norme	No. Nr Numéro No n.	Approved body Prüfung durch Organisme agréé Aprobado Collaudato																										
EN ISO	4413:2010	Self																										
EN ISO	12100:2010	Self																										
EN ISO	28927-2:2009 +A1:2017	Self																										
EN ISO	3744:2010	Self																										
EN ISO	11148-6:2012, Cl. 5.4	Self																										
EN ISO	11148-6:2012, Cl. 5.5	Self																										
EN ISO	13732-1:2008	Self																										
Machinery Directive	2006/42/EC:2006	Self																										
<p>5. Special Provisions: Spezielle Bestimmungen: Dispositions particulières: Provisiones especiales: Disposizioni speciali:</p>	<p>None</p>																											
<p>6. Representative in the Union: Vertreter in der Union/Représentant dans l'union/Representante in la Union/Rappresentante presso l'Unione</p>	<p>Patrick Vervier, Stanley Dubuis 17-19, rue Jules Berthonneau-BP 3406 41034 Blois Cedex, France.</p>																											
<p>Done at/Ort/Fait à/Dado en/Fatto a <u>STANLEY Infrastructure, Milwaukie, Oregon USA</u> Date/Datum/le/Fecha/Data <u>4-12-2021</u></p>																												
<p>Signature/Unterschrift/Signature/Firma/Firma _____ Position/Position/Fonction/Cargo/Posizione <u>North America Quality Engineer</u></p>																												

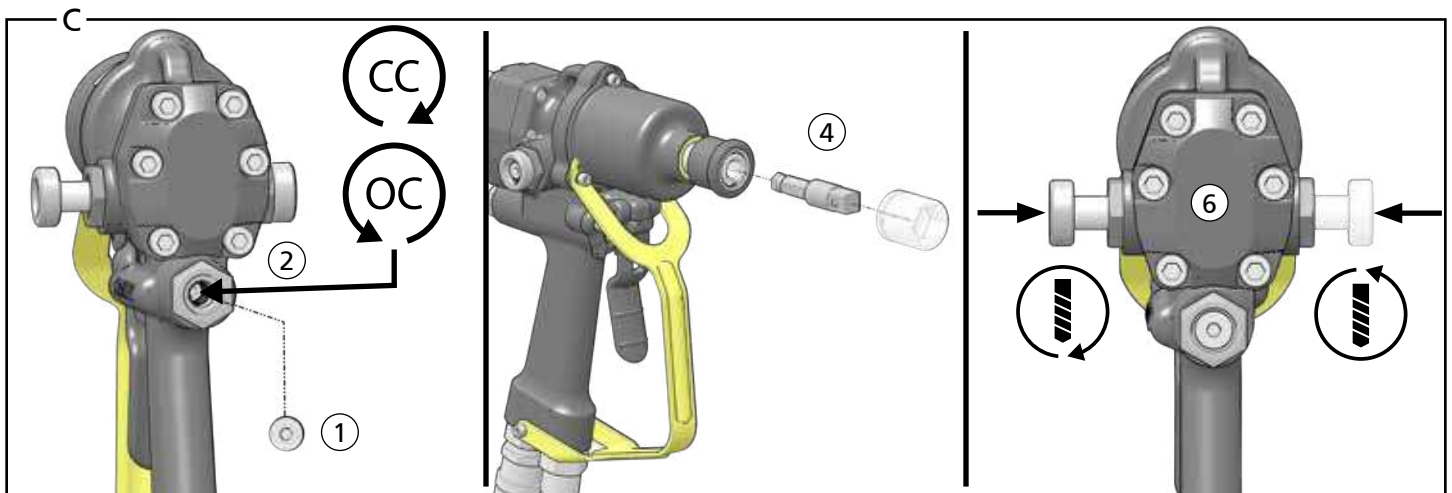
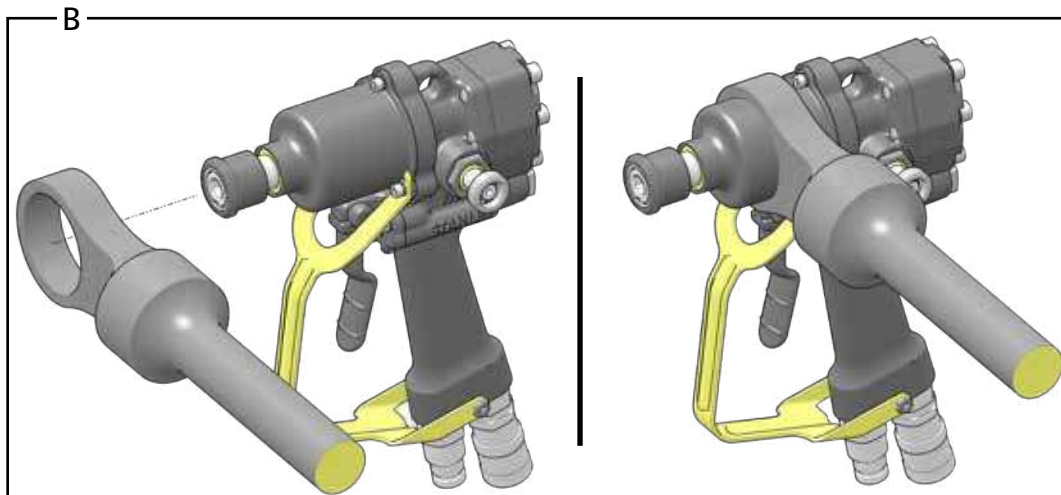
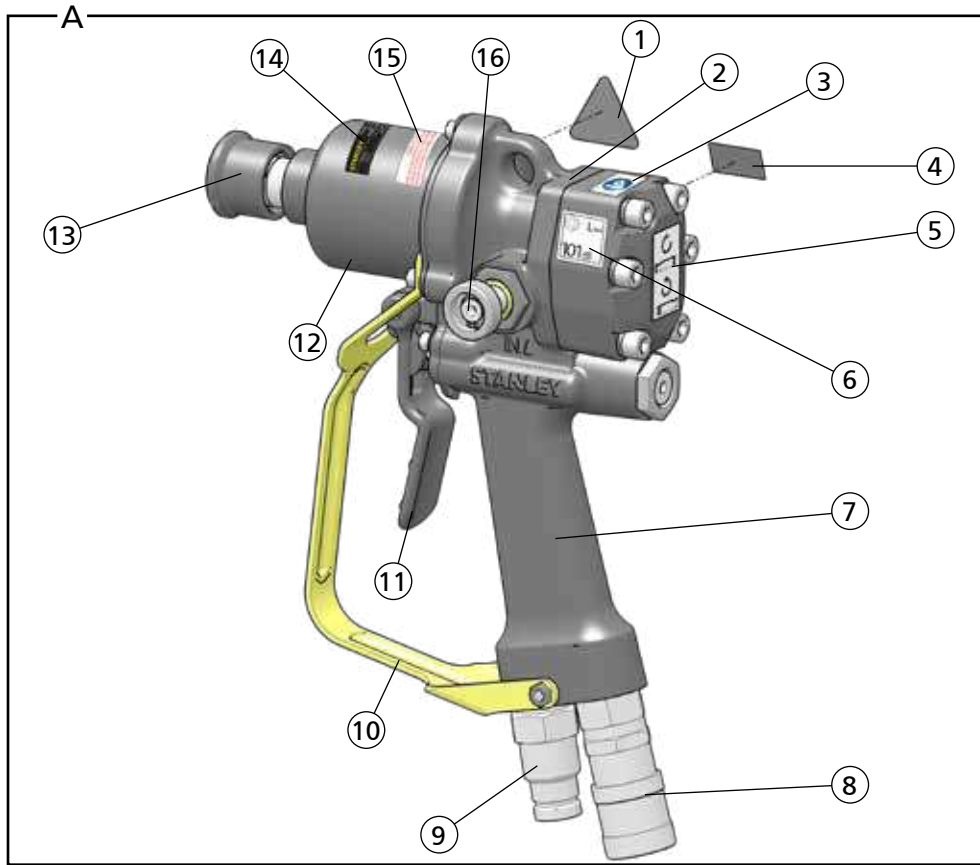

D

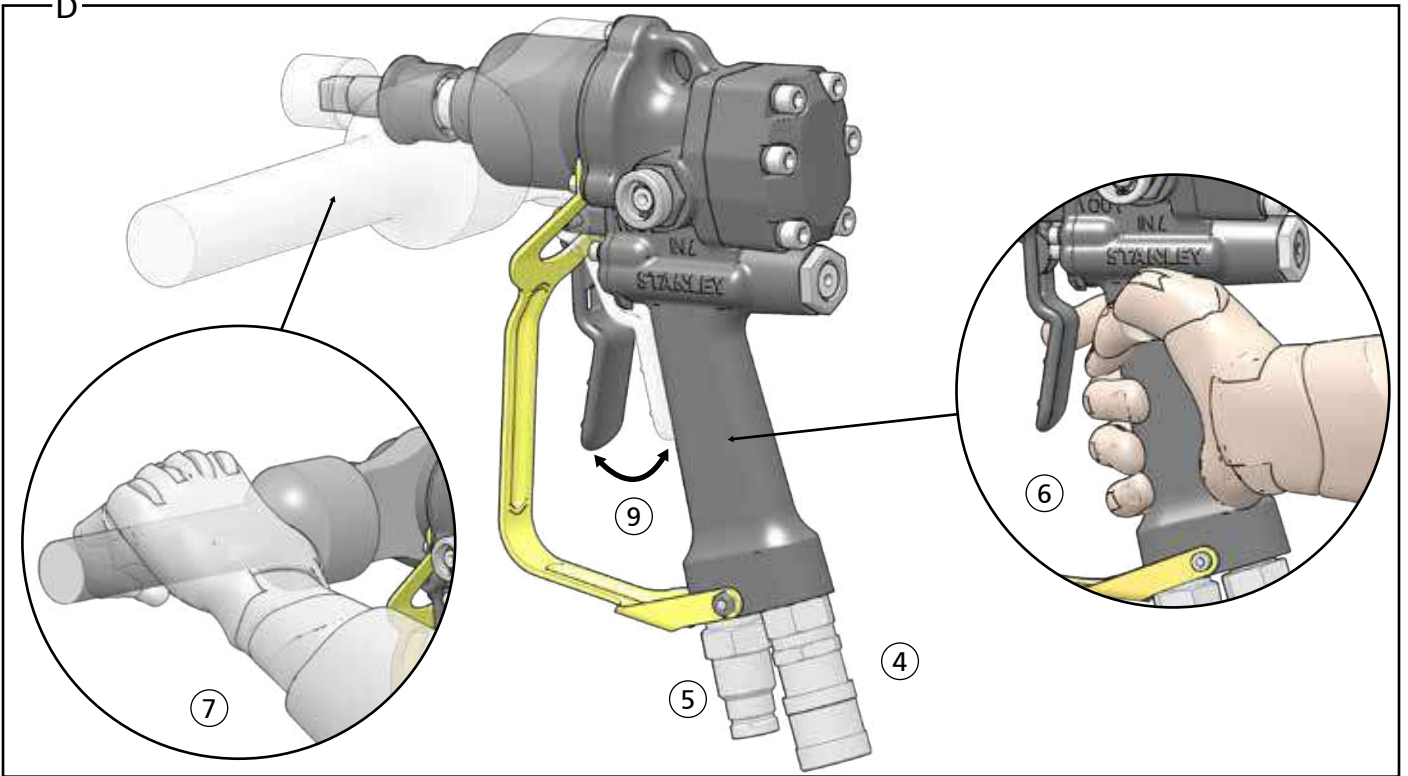

E

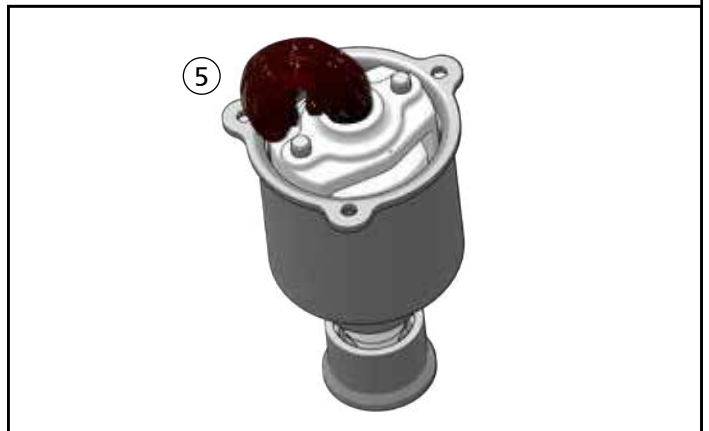
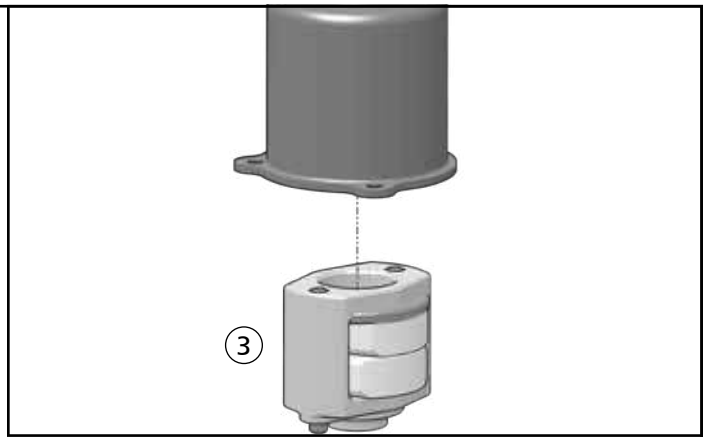
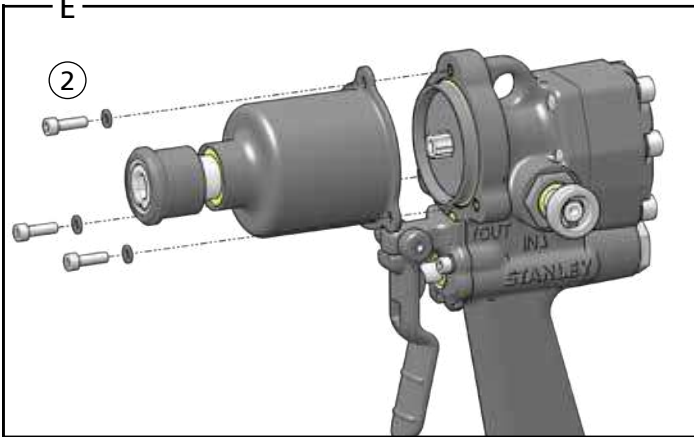

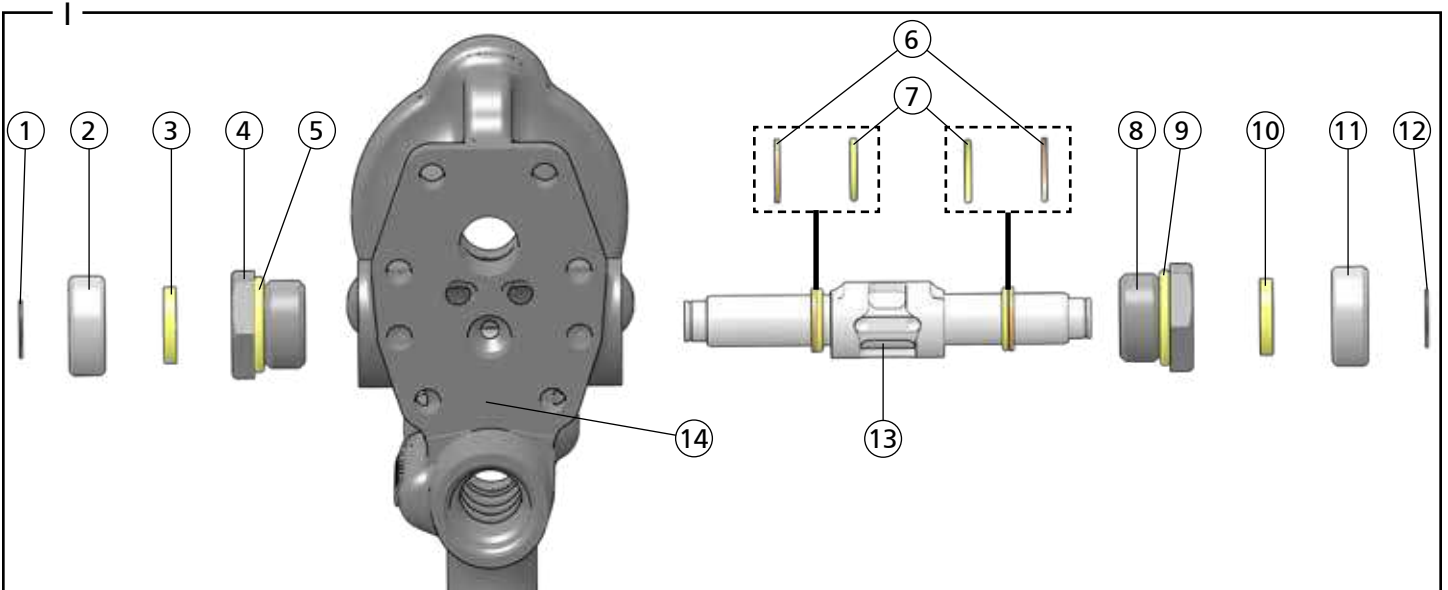
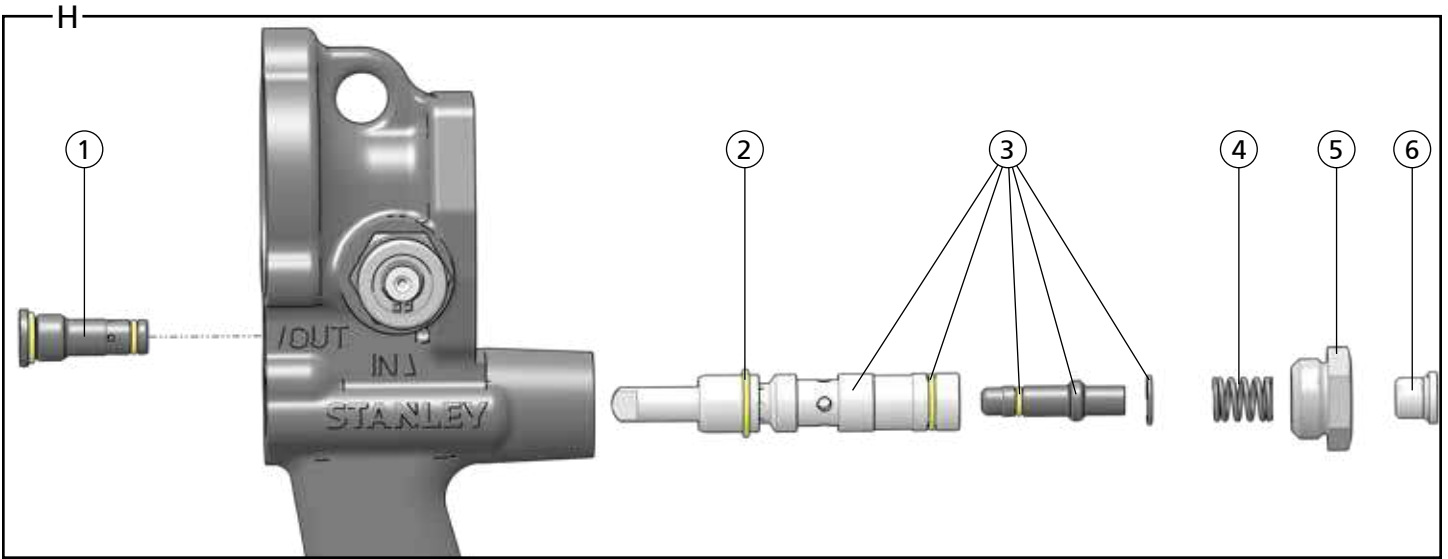

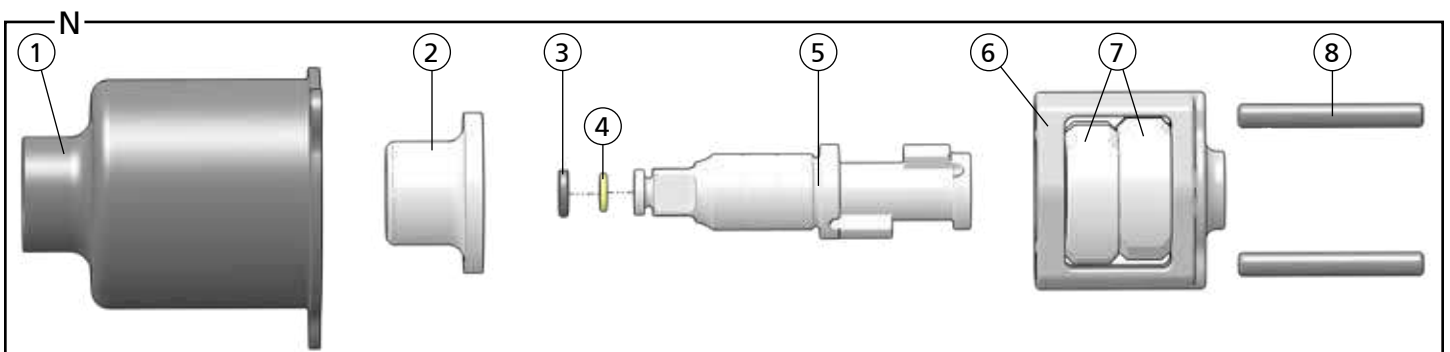
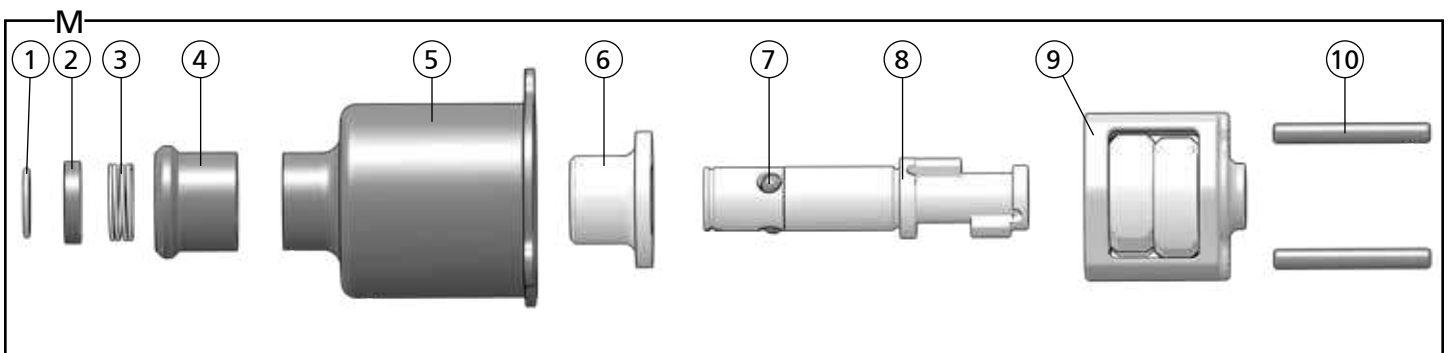
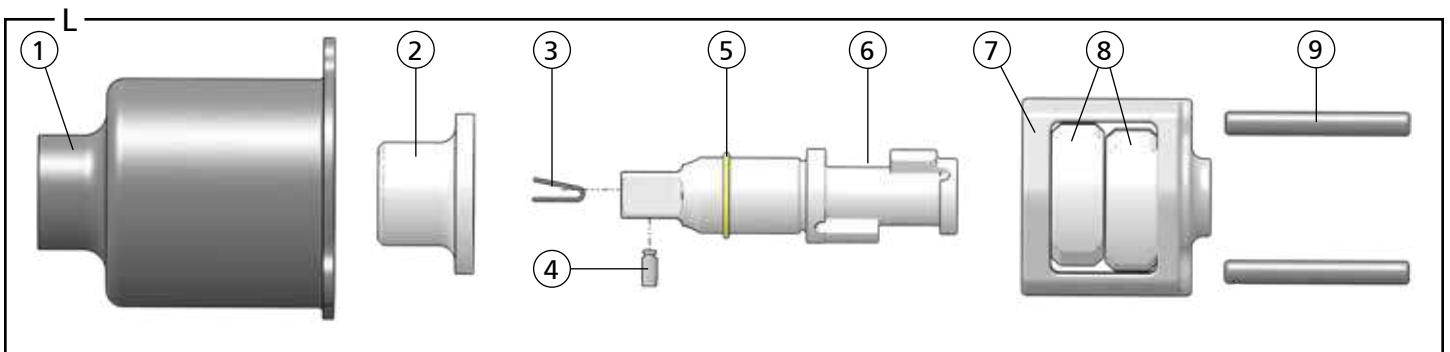
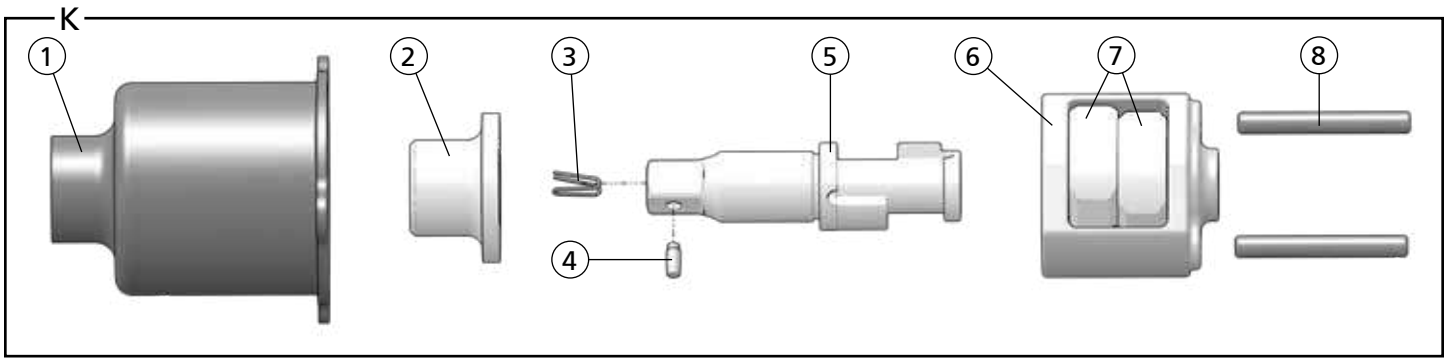
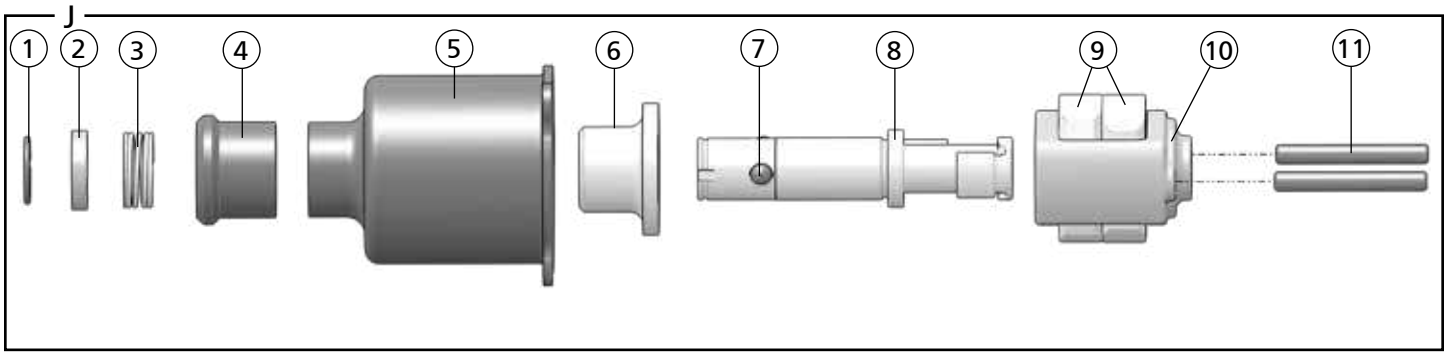

ID07 Parts Illustration - Detail F		
ITEM	P/N	DESCRIPTION
1	05117	7/16 Inch Hex Adapter
2	62229	Cap Screw
3	09623	Lock Washer
4	74678	Tool Name Tag
5	11207	Circuit Type "D" Decal
6	11354	Open Center / Closed Center Decal
7	01205	O-ring*
8	30704	Spacer
9	20761	Bearing Race
10	06635	Retaining Ring
11	20767	Seal Back-up Washer
12	13995	Back-up Ring*
13	00354	O-ring*
14	32029	Pilot Ring
15	28323	CE Decal (CE Models)
	58862	Pressure Warning Decal (Non-CE Models)
16	88348	Read the Manual Decal (CE Models)
17	66653	Sound Power Decal - Model ID0781501
	29530	Sound Power Decal - Models ID0782001, ID0792001
	58864	Electrical Warning Decal - (Non-CE Models)
18	29149	Rotation Direction Decal
19	58718	Coupler Set - Models ID0781501, ID782001
	03971	Coupler Set - Models ID07810S, ID0781506, ID07815AS, ID07830K, ID0792001
	81160	Coupler Set - Models ID07815AB, ID07810B
	03971	Coupler Set - Model ID0781010
20	00936	Adapter - Models ID07810, ID07810M, ID07815, ID0781506, ID077820, ID07830
21	20762	Bearing
22	07724	Nylock Nut - Models ID07810B, ID07810S, ID07815, ID0781501, ID0781506, ID07815AB, ID07815AS, ID0782001, ID0792001
23	09687	Cap Screw - Models ID07810B, ID07810S, ID07815, ID0781501, ID0781506, ID07815AB, ID07815AS, ID0782001, ID0792001
24	60710	Trigger Guard - Models ID07810B, ID07810S, ID07815, ID0781501, ID0781506, ID07815AB, ID07815AS, ID0782001, ID0792001
25	56725	Hose Assembly (not shown) - Models ID07810S, ID07815AS
	66727	Hose Assembly (not shown) - Models ID07810B, ID07815AB
	65617	Hose Assembly (not shown) - Model ID0781010
26	60791	ID07 Seal Kit (not shown) (* In seal kit)

ID07 Trigger & Motor Parts Illustration - Detail G		
ITEM	P/N	DESCRIPTION
1	62229	Cap Screw
2	09623	Lock Washer
3	07970	Roll Pin
4	60678	Trigger Mount

ID07 Trigger & Motor Parts Illustration - Detail G		
ITEM	P/N	DESCRIPTION
5	60677	Trigger
6	49139	Seal Wiper*
7	01262	O-ring*
8	20788	Main Shaft
9	20758	Bushing
10	05207	Bushing
11	20770	Motor Cap Assembly (Includes 1x 05207, 2x 00713)
12	18206	Cap Screw
13	00231	Lock Washer
14	00713	Dowel Pin
15	20769	Idler Gear Assembly
16	31246	Idler Shaft
17	31665	Spring
18	31299	Plunger
19	60791	ID07 Seal Kit (not shown) (* in seal kit)

ID07 Trigger Valve Parts Illustration - Detail H		
ITEM	P/N	DESCRIPTION
1	56721	Relief Cartridge
2	07627	O-ring*
3	48986	Valve Spool Assembly
4	65480	Spring
5	56758	Spring Cap
6	350041	Hex Plug
7	60791	ID07 Seal Kit (not shown) (* in seal kit)

ID07 Rotation Direction Valve Parts Illustration - Detail I		
ITEM	P/N	DESCRIPTION
1	56764	Retaining Ring
2	56757	End Cap
3	56747	Seal Wiper
4	56749	Seal Cap
5	01604	O-ring*
6	07224	Back-up Ring*
7	00175	O-ring*
8	56749	Seal Cap
9	01604	O-ring*
10	56747	Seal Wiper
11	56757	End Cap
12	56764	Retaining Ring
13	56765	Reversing Spool
14	59049	Main Tool Housing Assembly
15	60791	ID07 Seal Kit (not shown) (* in seal kit)

ID07 Impact Mechanism 31894 Parts Illustration - Detail J		
Models ID07810, ID07810B, ID07810S, ID07815, ID0781501, ID0781506, ID07815AB, ID07815AS		
ITEM	P/N	DESCRIPTION
1	31901	Thrust Ring Lock
2	31900	Thrust Ring
3	31899	Spring
4	31902	Retaining Ring
5	31904	Hammer Case
6	31903	Hammer Case Bushing
7	15966	Steel Ball
8	31898	Anvil
9	31897	Hammer
10	31896	Hammer Frame
11	06757	Hammer Pin

ID07 Impact Mechanism 32149 Parts Illustration - Detail K		
Models ID07820, ID0782001		
ITEM	P/N	DESCRIPTION
1	31904	Hammer Case
2	31903	Hammer Case Bushing
3	08416	Spring
4	32151	Retainer
5	72900	Anvil
6	31896	Hammer Frame
7	31897	Hammer
8	06757	Hammer Pin





ID07 Impact Mechanism 32284 Parts Illustration - Detail L		
Models ID07920, ID0792001		
ITEM	P/N	DESCRIPTION
1	31904	Hammer Case
2	32153	Hammer Case Bushing
3	08416	Spring
4	32151	Retainer
5	00012	O-ring*
6	72900	Anvil
7	31896	Hammer Frame
8	31897	Hammer
9	06757	Hammer Pin
10	60791	ID07 Seal Kit (not shown) (* in seal kit)

ID07 Impact Mechanism 67297 Parts Illustration - Detail M		
Models ID07810M		
ITEM	P/N	DESCRIPTION
1	31901	Thrust Ring Lock
2	31900	Thrust Ring
3	31899	Spring
4	31902	Retaining Sleeve
5	31904	Hammer Case
6	31903	Hammer Case Bushing

ID07 Impact Mechanism 67297 Parts Illustration - Detail M		
Models ID07810M		
ITEM	P/N	DESCRIPTION
7	15933	Steel Ball
8	31898	Anvil
9	31896	Hammer Frame
10	06757	Hammer Pin

ID07 Impact Mechanism 67637 Parts Illustration - Detail N		
Models ID07830, ID07830K		
ITEM	P/N	DESCRIPTION
1	31904	Hammer Case
2	31903	Hammer Case Bushing
3	72902	Anvil Friction Ring
4	72903	O-ring
5	72901	Anvil
6	31896	Hammer Frame
7	31897	Hammer
8	06757	Hammer Pin

Safety Precautions

	The Safety Alert Symbol alerts you to potential personal injury hazards. Obey all safety messages that follow to avoid possible injury or death.
	Indicates an imminently hazardous situation which will result in death or serious injury.
	Indicates a potentially hazardous situation which could result in death or serious injury.
	Indicates a potentially hazardous situation which could result in property damage.

Always observe safety symbols. They are included for your safety and for the protection of the tool.



WARNING: Read all safety warnings and instructions. Failure to follow warnings and instructions may result in tool damage and/or serious injury.

WARNING: To reduce the risk of injury, read the instruction manual.

General

- Do not discard safety instructions. Give to the operator.
- This tool will provide dependable service if operated in accordance with the instructions given in this manual. Read and understand this manual and any stickers and tags attached to the tool and hoses before operation. Failure to do so could result in personal injury or equipment damage.
- Inspect the tool before each use and ensure all decals are legible. Contact STANLEY if replacements are needed.
- Establish a training program for all operators to ensure safe operation. Do not operate the tool unless thoroughly trained or under the supervision of an instructor. Keep out of the reach of children.
- Operators and maintenance personnel shall be able to physically handle the bulk, weight and power of the tool.
- Avoid unsuitable postures as these positions do not allow for counteracting of normal or unexpected movement of the tool, such as a sudden break of the tool bit. Change postures during extended tasks to help avoid discomfort or fatigue.
- Do not operate a damaged, improperly adjusted, modified or incompletely assembled tool.
- Do not operate the tool in explosive atmospheres, such as in the presence of flammable liquids, gases or dust. Power tools create sparks which may ignite the dust or fumes.
- Provide adequate ventilation in closed areas when operating a gas or diesel hydraulic power source.
- Do not inspect, carry, clean, change accessories or perform maintenance on the tool while the power source is connected. Accidental engagement of the tool can cause serious injury.
- Ensure work piece is securely fixed. Be aware that failure of the work piece or accessories may generate high velocity projectiles.
- Stay alert, watch what you are doing and use common sense when operating a hydraulic tool. Do not operate this tool if you are tired or under the influence of drugs or alcohol. A moment of inattention while operating hydraulic tools may result in serious injury.
- Assess risks to others around you before operating the tool.
- During operation, do not contact mechanisms, accessories or hardware as they can become very hot; use your Personal Protection Equipment (PPE).
- Use and maintain the tool as stated in this manual. Misuse of this tool is forbidden. Misuse of the tool can cause serious injury. Do not modify the tool in any way.
- Supervising personnel should develop additional precautions relating to the specific work area and local safety regulations.
- Never operate the tool if you cannot be sure that underground utilities are not present, such as electrical cables, gas pipes, etc. These can cause a hazard if damaged with the tool.
- The tool is not insulated against coming into contact with electric power. Use hose certified as non-conductive.
- Do not overreach. Maintain proper footing and balance at all times when using the tool.
- Slips, trips and falls are major causes of workplace injury. Be observant of hoses lying about the work area, as they can be a tripping hazard.

- Operator must start in a work area without bystanders and must assess the risk to bystanders, including the risk of serious injury or death caused by the tool or accessories dropped from an elevated height.
- Operators must be familiar with all prohibited work areas such as excessive slopes and dangerous terrain conditions.
- Only use clean hydraulic fluid and lubricants that have been recommended by STANLEY.
- Ensure tools are working properly and safely by performing preventative maintenance (PM) procedures.
- Repair and service of this tool must only be performed by an authorized and certified dealer.
- Use only replacement parts recommended by STANLEY.
- Do not force the tool to do the work of a larger tool. Use the correct tool for your application.
- Use only hoses and hose couplings that are rated for a minimum working pressure of 2500 PSI (172 BAR).
- Keep hands away from rotating chuck, drill bits or drives.
- Rotating drive sockets and drive extensions can easily entangle rubber-coated gloves or metal reinforced gloves. Never hold the drive, sockets, drive extensions or other accessories.
- Do not use in confined spaces. Beware of crushing hazards between the tool and the workpiece, especially when unscrewing or reversing the tool.
- Keep the work area well lit.
- Prevent unintentional starting. Ensure the trigger is in the off position before connecting to power source, picking up or carrying the tool. Carrying power tools with your finger on the trigger or energizing power tools that have the trigger on invites accidents.
- In spite of the application of relevant safety regulations and the implementation of safety devices, certain residual risks cannot be avoided. These risks are: repetitive strain injury due to incorrect posture and risk of pinching fingers when changing tool bit or pressing trigger.

Dust and Fumes

- **WARNING:** Some dust created by power sanding, sawing, grinding, drilling, and other construction activities contains chemicals known to the State of California to cause cancer, birth defects or other reproductive harm. Some examples of these chemicals are:
 - Lead from lead-based paints,
 - crystalline silica from bricks and cement and other masonry products, and
 - arsenic and chromium from chemically-treated lumber.
- Your risk from these exposures varies, depending on how often you do this type of work. To reduce your exposure to these chemicals: work in a well ventilated area, and work with approved safety equipment, such as those dust masks that are specially designed to filter out microscopic particles.
- Protect yourself and those around you. Research and understand the materials you are drilling. Follow correct safety procedures and comply with all applicable national, state or provisional health and safety regulations relating to them, including, if appropriate arranging for the safe disposal of the materials by a qualified person.
- When dust or fumes are created, control them at the point of emission. Direct tool exhaust to minimize disturbance of dust.
 - Operate and maintain the tool as recommended in this manual to minimize dust.
 - Use respiratory protection in accordance with employers instruction or as required by occupational health and safety regulations.
 - Avoid prolonged contact with dust. Allowing dust to get into your mouth, eyes or lay on the skin may promote absorption of harmful chemicals.
 - Select and replace tool bits as recommended in order to prevent an unnecessary increase in dust or fumes.
 - Keep tool handles dry, clean and free from oil and grease. This will enable better control of the tool.

PPE

- Always wear safety equipment such as impact resistant goggles, ear protection, head protection, breathing protection and safety shoes at all times when operating the tool.
- Hands may be exposed to hazards, impacts, cuts, abrasions and heat. Wear gloves.
- Wear a hardhat if performing overhead work.
- Use PPE that conforms to standards ANSI Z87.1 (Eye and Face

Protection), ANSI Z89.1 (Head Protection), ANSI Z41.1 (Foot Protection) and ANSI S12.6 (S3.19) (Hearing Protection).

- Do not wear loose fitting clothing, jewelry or gloves with cut or frayed fingers when operating the tool. Entanglement, choking, scalping and laceration can occur if loose clothing, personal jewelry, neck wear, hair or gloves are not kept away from the rotating tool and it's accessories. Gloves can become entangled with the rotation drive, causing severed or broken fingers.



M003
Wear Ear
Protection



M004
Wear Eye
Protection



M016
Wear a Mask

Sound

- Exposure to high noise levels can cause permanent, disabling hearing loss and other problems, such as tinnitus (ringing, buzzing, whistling or humming in the ears). Use hearing protection in accordance with employer's instructions and as required by occupational health and safety regulations. Appropriate controls to reduce the risk can include actions such as damping materials to prevent work pieces from "ringing".
- Use and maintain as recommended in the manual to prevent an unnecessary increase in noise levels.

Vibration

- When using a rotary or percussive tool to perform work related activities, the operator can experience discomfort in the hands, arms, shoulders, neck or other parts of the body.
- If you experience numbness, tingling, pain or whitening of the skin in your fingers or hands, stop using the tool. Tell your employer and consult a physician.
- Wear warm clothing when working in cold conditions and keep your hands warm and dry.
- Exposure to vibration can cause disabling damage to the nerves and blood supply of the hands and arms.
- Do not use worn or ill-fitting sockets or extensions, as this is likely to cause a substantial increase in vibration.
- Do not touch sockets or accessories during impacting. This increases the risk of cuts, burns or vibration injuries.
- Use and maintain as recommended in the manual to prevent an unnecessary increase in vibration.
- Check the vibration level after each service. If higher than normal, contact your STANLEY dealer.

Hydraulic

- **Warning:** Hydraulic fluid under pressure could cause skin injection injury. Do not check for leaks with your hands. If you are injured by hydraulic fluid, get medical attention immediately.
- Do not let hydraulic oil get on the skin. Hydraulic oil is hot. Wear Personal Protection Equipment (PPE) at all times.
- If exposed to hydraulic fluid, wash hands immediately.
- Do not exceed the maximum relief valve setting stated on the tool.
- Inspect and clean couplers before use, daily. Replace damaged couplers immediately.
- Hydraulic circuit control valve must be OFF before coupling or uncoupling tools. Failure to do so may damage the couplers and cause overheating of the hydraulic system.
- Ensure the couplers are properly connected and are tight.
- Do not operate the tool at fluid temperatures above 140°F (60°C). Higher temperatures can cause operator discomfort and damage to the tool.
- Do not exceed the rated flow and pressure as stated on the tool. Rapid failure of the internal seals may result.

What is the ID07 Hydraulic Impact Drill?

ID07 is a high torque impact wrench used for tightening nuts, driving lag bolts or auguring through difficult materials, such as telephone poles.

Specifications		
Pressure	2000 PSI (140 BAR)	
Flow	4-12 GPM (15-46 LPM)	
RPM	7679 @ 12 GPM (46 LPM)	
Max. Pressure	2500 PSI (172 BAR)	
Max. Relief Pressure	2100 PSI (145 BAR)	
Recommended Back Pressure	250 PSI (17 BAR) - Can be used with higher back pressures with reduced seal life.	
Couplers	3/8 Inch, NPT Pipe Fitting	
Port Size	-8 SAE O-ring	
Tool Weight	7 Lbs. (3.2 Kg)	
Tool Size	13 Inches x 5 Inches x 12 Inches	
Max. Hydraulic Oil Temperature	140°F (60°C)	
HTMA/EHTMA Category	Type II - Category D	
Underwater Tool Max. Depth	1000 Feet (305 M)	
Recommended Hose Diameters for Underwater Applications		
Depth	8 GPM (30 LPM)	12 GPM (45 LPM)
100 Feet (31 Meters)	5/8 Inches (16 mm)	5/8 Inches (16 mm)
300 Feet (91 Meters)	3/4 Inches (19 mm)	1 Inch (25.4 mm)
600 Feet (183 Meters)	1 Inch (25.4 mm)	1 Inch (25.4 mm)
1000 Feet (305 Meters)	1 Inch (25.4 mm)	1 1/4 Inches (32 mm)

Sound & Vibration Declaration	
Measured A-Weighted sound power level	101.1 dBA
Uncertainty	3.39 dBA
Measured A-Weighted Sound Pressure	93.1 dBA
Uncertainty	3.39 dBA
Values determined according to noise test code given in ISO 15744, 11203 and 3744.	
Declared vibration emission value in accordance with EN ISO 28927-2.	
Declared Vibration Emission Value:	8.5 m/sec ²
Uncertainty	1.74 m/sec ²

Parts of an ID07 - Detail A

1	Circuit Type "D" Decal
2	Serial Number & Year of Manufacture
3	Read the Manual Decal (CE Models)
4	CE Decal (CE Models)
	Pressure Warning Decal (Non-CE Models)
5	Rotation Direction Decal
6	Sound Power Decal (CE Models)
	Electrical Warning Decal (Non-CE Models)
7	Handle
8	Female Hydraulic Coupler
9	Male Hydraulic Coupler
10	Trigger Guard

11	Trigger
12	Impact Mechanism
13	Bit Retainer
14	Tool Name Tag
15	Open Center / Closed Center Decal
16	Rotation Direction Spool

Tool Setup

⚠ WARNING

Do not install or change tool accessories while the hydraulic power source is connected. Accidental engagement of the tool can cause serious injury. Disconnect the hydraulic power source before installing or changing accessories.

1. Disconnect the tool from the hydraulic power source.

Install the Assist Handle - Detail B

ID07 may be equipped with an assist handle as an accessory (see "ID07 Accessories" on page 12). The assist handle helps to absorb reaction torque and control the tool. Loss of control can cause personal injury. STANLEY recommends you use the assist handle whenever possible.

1. Place the assist handle over the hammer case.
2. Tighten the handle.

Set Hydraulic Circuit Type - Detail C

1. Remove the hex plug on the back of the tool handle.
2. Turn the selector screw completely clockwise for open center operation -OR- completely counter clockwise for closed center operation.
3. Reinstall the hex plug.

Insert Bit - Detail C

⚠ WARNING

Use only impact-rated sockets and accessories. Do not use sockets or accessories that are in poor condition. These can crack or fracture during operation and can become a projectile.

4. Insert the bit while pushing back on the tool retaining sleeve.
5. Lock the tool retaining sleeve in place.

Note: Never operate the tool unless the inserted bit is properly retained. Bits can become a high velocity projectile.

Choose Drill Rotation Direction - Detail C

6. Push the rotation direction spool left for clockwise bit rotation -OR- right for counter clockwise bit rotation.

Tool Operation - Detail D

Connect to a Hydraulic Power Source

1. Using a calibrated flow and pressure gauge, check the output of the hydraulic power source. Ensure it matches the flow and pressure in "Specifications" on page 11. Hydraulic fluid must be 50°F or above. Preheat if necessary.

Note: Check the hydraulic power source once a day. Proper flow and pressure are critical to maintaining proper tool speed.

2. Ensure that the hydraulic power source is equipped with a relief valve set to open at the maximum relief pressure, see "Specifications" on page 11.
3. Wipe hose couplers with a clean, lint free cloth.
4. Connect the return hose to the tool port marked "Out".
5. Connect the pressure hose to the tool port marked "In".

Using the Tool

Bolt Types for Use with ID07	
Bolt Grade	Thread Sizes
SAE Grade 2	7/16 - 7/8 Inch
SAE Grade 5	3/8 - 5/8 Inch
SAE Grade 8	3/8 - 9/16 Inch

- Hold the main tool handle with your dominant hand.
- Hold the assist handle with your non-dominant hand.
- Place the socket or accessory on the material or fastener.
- Squeeze the trigger.

Note: Hold the tool correctly and be ready to counteract normal or sudden movements. Have both hands available. High reaction torque can develop if the tool stalls, which can be caused by excessive loads being applied to the drill bit, by the drill snagging on the material being drilled into or by the drill bit breaking through the material being drilled.

- Release the trigger to stop the tool.

Note: If you encounter a breakdown or the tool stops for any reason, release the trigger and power down the hydraulic power source.

Tool Use Tips

- Heavy, loose or multiple adapters can dissipate the intensity of impact. Use as few adapters as possible and ensure they fit tightly. Loose fitting sockets will increase vibration.
- Hold the tool with a light, but safe grip. Risk from vibration is greater with higher grip force.
- Maximum torque can be obtained by continuously impacting for 10 seconds.
- Hydraulic flow and pressure from the hydraulic power source will dramatically influence the tool impact force and speed. Regularly check the hydraulic power source. See "Specifications" on page 11.

Tool Maintenance

Daily Maintenance

- Remove hydraulic power from the tool
- Check all hydraulic connections and hoses for damage. Replace damaged parts before operating the tool.
- Inspect the tool retainer and associated parts. Replace when they have become worn, cracked or distorted.
- Inspect tool to ensure all decals are legible. Contact STANLEY if replacements are needed.

Grease the Impact Mechanism - Detail E

Grease the impact mechanism if ID07 shows signs of reduced impact force. For underwater models, grease after every use.

CAUTION

Regrease the impact mechanism regularly. A dry impact mechanism can create sparks and may damage the tool.

- Remove hydraulic power from the tool.
 - Remove the 3 cap screws that hold the impact housing to the tool body.
 - Turn the impact housing over into your hand. Lift the housing and the impact mechanism will fall into your hand.
 - Fill the cavity with clean premium lithium complex grease.
- Note: STANLEY recommends Mobile Delvax Xtream grease.
- Put the impact mechanism back into the impact housing. Grease will extrude out of the bottom hole of the impact mechanism.
 - Put the impact housing assembly back onto the tool body.

Underwater Tool Maintenance

Perform maintenance on underwater models after each use.

- Remove hydraulic power from the tool.
- Clean and grease the impact mechanism. See "Grease the Impact Mechanism - Detail E" on page 12.
- Using a water displacing oil, spray into the trigger.
- Spray or dip the entire tool.

Tool Storage & Transport

Drain the tool of hydraulic fluid and plug open hydraulic ports. Collect all hydraulic fluid for recycling (see "Tool Disposal" on page 12). Clean the tool and store in a clean, dry space that is safe from damage. Ensure the tool is secured and will not move during transport. An unsecured tool could cause personal injury or damage to the tool.

Tool Disposal

Hydraulic Oil

Hydraulic oil can contaminate the air, ground and water if not properly recycled. Recycle hydraulic oil in accordance with all State, Federal and local laws, at your local oil recycling facility.

Hydraulic Hoses

Hang hydraulic hoses to drain. Collect the oil for recycling. Contact your local municipal recycling authorities for an approved hydraulic hose recycling site.

Tool Body

Drain hydraulic oil from the tool, making sure to collect the oil for recycling. Disassemble the tool and dispose of all non-metal parts. Recycle the metal components. Contact your local municipal recycling authorities for recycling instructions.

Accessories

ID07 Accessories	
Description	Part Number
Assist Handle	73636
7/16 Inch Quick Change Chuck to 1/2 Inch Square, Female	05079
7/16 Inch Hex Shank to 1/2 Inch Square Adapter, Male	05117
5/8 Inch Quick Change Adapter to 1/2 Inch Square, Female	07192
5/8 Inch Male Hex x 1/2 Inch Male Square Drive	05080

1/2 Inch Square Drive Sockets	
Description	Part Number
9/16 Inch, Double Square, 8 Point Deep Length	05109
5/8 Inch, Double Square, 8 Point Deep Length	05110
1/16 Inch, Double Square, 8 Point Deep Length	05111
3/4 Inch, Double Square, 8 Point Deep Length	05112
13/16 Inch, Double Square, 8 Point Deep Length	05113
7/8 Inch, Double Square, 8 Point Deep Length	05114
15/16 Inch, Double Square, 8 Point Deep Length	05115
1 Inch, Double Square, 8 Point Deep Length	05116
Linemans Socket, 13/16 & 15/16 Inch	33155
Linemans Socket, 1 & 1 1/8 Inch	33156

Carbide Tipped Wood Auger Bits - 5/8 Inch Hex			
Ø	Length	Overall Length	Part Number
9/16 Inch	18 Inch	22 Inch	27845
13/16 Inch	18 Inch	22 Inch	27847

Carbide Tipped Wood Auger Bits - 7/16 Inch Hex			
Ø	Length	Overall Length	Part Number
9/16 Inch	8 Inch	12 Inch	27850
11/16 Inch	8 inch	12 Inch	27851

Carbide Tipped Wood Auger Bits - 7/16 Inch Hex			
Ø	Length	Overall Length	Part Number
13/16 Inch	8 Inch	12 Inch	27852
15/16 Inch	8 Inch	12 Inch	27853
1 1/16 Inch	8 Inch	12 Inch	27854
9/16 Inch	12 Inch	16 Inch	27855
11/16 Inch	12 Inch	16 Inch	27856
13/16 Inch	12 Inch	16 Inch	27857
15/16 Inch	12 Inch	16 Inch	27858
1 1/16 Inch	12 Inch	16 Inch	27859
9/16 Inch	18 Inch	22 Inch	27860
11/16 Inch	18 Inch	22 Inch	27861
13/16 Inch	18 Inch	22 Inch	27862
15/16 Inch	18 Inch	22 Inch	27863
1 1/16 Inch	18 Inch	22 Inch	27864
13/16 Inch	36 Inch	48 Inch	27869

Troubleshooting		
Problem	Possible Cause	Solution
Tool will not start, is running too fast or too slow.	The hydraulic power source is not running or not running properly.	Ensure the power source is delivering proper flow and pressure. See "Specifications" on page 11. Proper flow and pressure maintain proper tool speed. Check regularly.
	The hydraulic power source is not running or not running properly.	Ensure the power source is delivering proper flow and pressure. See "Specifications" on page 11. Proper flow and pressure maintain proper tool speed. Check regularly.
Tool has low impact performance.	Hydraulic hoses are reversed.	Install hydraulic hoses properly. See "Connect to a Hydraulic Power Source" on page 11.
	Defective quick disconnects.	Inspect for damage or blockage. Replace if necessary.
	Incorrect grease in the impact mechanism or the mechanism maintenance hasn't been performed.	Grease the impact mechanism. See "Grease the Impact Mechanism - Detail E" on page 12.
	Motor or impact mechanism failure.	Contact your STANLEY dealer for service.
Hydraulic oil is too hot or the hydraulic power unit is working too hard when running the tool.	Hydraulic circuit type set incorrectly.	Ensure the hydraulic circuit type on the tool is set to match your hydraulic system. See "Set Hydraulic Circuit Type - Detail C" on page 11.
	Hydraulic power source is not running properly.	Ensure the power source is delivering proper flow and pressure. See "Specifications" on page 11. Proper flow and pressure maintain proper tool speed. Check regularly.
	Relief valve is set too low.	Ensure your hydraulic system relief valve is set properly. See "Specifications" on page 11.
Oil is leaking from the reversing spool or motor cap.	Hydraulic hoses incorrectly connected to the tool.	Ensure the return and pressure hoses are properly attached to the tool. See "Connect to a Hydraulic Power Source" on page 11.
	Damaged O-Rings, loose fasteners or other damage.	Contact your STANLEY dealer for service.

STANLEY®

STANLEY Infrastructure
6430 SE Lake Road, Portland, Oregon 97222 USA
(503) 659-5660 / Fax (503) 652-1780
www.stanleyinfrastructure.com