

SEA TORCH®
ARCWATER®
SEA-STINGER®
SEA-PAK®

Arcair®

UNDERWATER CUTTING AND WELDING EQUIPMENT

SAFETY AND OPERATING INSTRUCTIONS



WE APPRECIATE YOUR BUSINESS!

Congratulations on your new Arcair® product. We are proud to have you as our customer and will strive to provide you with the best service and reliability in the industry. This product is backed by our extensive warranty and world-wide service network. To locate your nearest distributor or service agency call 800-426-1888, or visit us on the web at www.tweco.com.

This Manual has been designed to instruct you on the correct installation and use of your Arcair® product. Your satisfaction with this product and its safe operation is our ultimate concern. Therefore, please take the time to read the entire manual, especially the Safety Precautions. They will help you to avoid potential hazards that may exist when working with this product.

YOU ARE IN GOOD COMPANY!

The Brand of Choice for Contractors and Fabricators Worldwide.

Arcair® is a Global Brand of Arc Cutting Products for Thermadyne Industries Inc. We manufacture and supply to major welding industry sectors worldwide, including: Manufacturing, Construction, Mining, Automotive, Aerospace, Engineering, Rural and DIY/Hobbyist.

We distinguish ourselves from our competition through market-leading, dependable products that have stood the test of time. We pride ourselves on technical innovation, competitive prices, excellent delivery, superior customer service and technical support, together with excellence in sales and marketing expertise.

Above all, we are committed to develop technologically advanced products to achieve a safer working environment within the welding industry.

 **WARNINGS**

Read and understand this entire Manual and your employer's safety practices before installing, operating, or servicing the equipment. While the information contained in this Manual represents the Manufacturer's judgment, the Manufacturer assumes no liability for its use.

Underwater Cutting and Welding Equipment

Safety and Operating Instructions

Manual No. 89250054

Published by:

Thermadyne® Industries, Inc.

2800 Airport Rd.

Denton, TX. 76208

(940) 566-2000

www.tweco.com

U.S. Customer Care: (800) 426-1888

International Customer Care: (905) 827-9777

Copyright © 2008 Thermadyne Industries, Inc. All rights reserved.

Reproduction of this work, in whole or in part, without written permission of the publisher is prohibited.

The publisher does not assume and hereby disclaims any liability to any party for any loss or damage caused by any error or omission in this Manual, whether such error results from negligence, accident, or any other cause.

Publication Date: September 12, 2008

Record the following information for Warranty purposes:

Where Purchased: _____

Purchase Date: _____

Equipment Serial #: _____

Table of Contents

SECTION 1: INTRODUCTION	1-1
1.01 How to Use this Manual	1-1
1.02 Receipt of Equipment	1-1
1.03 Description	1-1
SECTION 2: SAFETY PRECAUTIONS	2-3
SECTION 3: PROCESS VARIABLES	3-5
SECTION 4: UNDERWATER CUTTING	4-11
4.01 Oxygen/Arc Cutting Process	4-11
4.02 Exothermic Cutting Process	4-11
4.03 Oxygen and Amperage	4-13
4.04 Operating Techniques.....	4-13
4.05 Underwater Cutting Torch.....	4-15
SECTION 5: UNDERWATER WELDING	5-17
5.01 Underwater Dry Welding	5-17
5.02 Underwater Wet Welding.....	5-17
5.03 Welding Technique	5-18
5.04 Underwater Welding Equipment.....	5-20
SECTION 6: ARCWATER PROCESS	6-21
6.01 Principles of the Process.....	6-21
6.02 Applications.....	6-22
6.03 Procedure.....	6-22
6.04 Operation.....	6-23
6.05 Arcwater Equipment.....	6-23
6.06 Operating Data	6-24
SECTION 7: UNDERWATER ELECTRODES	7-25
7.01 Waterproof Coating	7-25
7.02 Flux Coating	7-25
7.03 Electrode Data	7-25
SECTION 8: SEA-PAK® 400A POWER SYSTEM	8-26
SECTION 9: MAINTENANCE	9-27
9.01 Sea Torch Disassembly	9-27
9.02 Arcwater II Disassembly.....	9-28
9.03 Sea-Stinger II Electrode Holder Disassembly	9-28

SECTION 10: PARTS LISTING..... 10-29

- 10.01 Sea Torch..... 10-29
- 10.02 Arcwater II Torch 10-30
- 10.03 Sea-Stinger II Electrode Holder..... 10-31

SECTION 11: STATEMENT OF WARRANTY..... 11-32

INTERNATIONAL
EVERYTHING UNDER PRESSURE

SECTION 1: INTRODUCTION

1.01 HOW TO USE THIS MANUAL

Information necessary to perform maintenance and service is contained in this manual. This information is intended for use by technicians or personnel qualified to repair and service this equipment. The information contained in this document, including performance specifications, is subject to change without notice. To ensure safe operation, read the entire manual, including the chapters on safety precautions and warnings.

Throughout this manual, the words **WARNING**, **CAUTION**, and **NOTE** may appear. Pay particular attention to the information provided under these headings. These special annotations are easily recognized as follows:

NOTE

NOTE conveys installation, operation, or maintenance information which is important but not hazard-related.



CAUTION

CAUTION indicates a potentially hazardous situation which, if not avoided, may result in injury.



WARNING

WARNING indicates a potentially hazardous situation which, if not avoided, could result in death or serious injury.

1.02 RECEIPT OF EQUIPMENT

When you receive the equipment, check it against the invoice to make sure it is complete and inspect the equipment for possible damage due to shipping. If there is any damage, notify the carrier immediately to file a claim. Furnish complete information concerning damage claims or shipping errors to the location in your area, listed on the back cover of this manual. Include a full description of the parts in error.

For additional or replacement copies of this manual, please contact the location in your area at the phone number listed on the back cover. Reference the manual number listed on Page i.

1.03 DESCRIPTION

For many years, cutting and welding processes have been used for a number of underwater applications: ship raising, repairs, construction in harbor facilities, removing machinery and fittings from unsalvageable hulls, removing twisted masses of wreckage and sunken ship hulls to clean harbors and shipping lanes, construction and repair damaged docks and ships. Plus a heavy work load exists in structural work and repairs of offshore drilling and production equipment.

This manual discusses underwater cutting and welding, the equipment, and provides information on underwater safety practices.

The Arcair Underwater Products is a complete line of underwater cutting and welding torches, electrode holders, and underwater cutting and wet welding electrodes.

The underwater environment puts special limits and restrictions on the operator by limiting time on the bottom, particularly at greater depths. Because time is vital in underwater work, saving even a few minutes is important in terms of work done per hour. Thus, the instructions in this manual should be carefully read and followed.

For a listing of available replacement parts or consumables, see the Arcair Underwater Products Catalog, Part# 89240001, or call Thermadyne Customer Care.

SECTION 2: SAFETY PRECAUTIONS



WARNING

SERIOUS INJURY OR DEATH may result if this underwater welding and cutting equipment is not properly installed, used, and maintained. Only trained professionals are allowed to perform underwater cutting and welding operations. All diving should be performed in accordance with all governing professional diving organizations regarding diving operations. Observe all safety precautions topside and underwater, during any diving operation. The operator, supervisor, and others in the work area must be aware of the dangers of underwater welding and cutting processes. Training and proper supervision are important for a safe dive operation. Keep these instructions for future use. Additional recommended safety and operating information is referenced in each section. No work of any kind should be permitted on the surface over the area where the diver will be working. The diver's work area radius should be at least equal the working depth of the dive.



WARNING

This product contains chemicals, including lead, or otherwise produces chemicals known to the State of California to cause cancer, birth defects and other reproductive harm. **Wash hands after handling.**
(California Health & Safety Code § 25249.5 et seq.)

ELECTRIC SHOCK CAN CAUSE INJURY OR DEATH



Inspect torch and other equipment to be sure all insulations and other protective covers are in place and in good condition at all times. Only use torches and electrode holders designed for underwater applications. Do not touch the electrode or any live electrical part and workpiece at the same time. The diver/welder/cutter must never allow themselves to become part of the electrical circuit. All electrical connections must be wrench tight and properly insulated. The use of AC power supplies for welding or cutting current is not recommended. There must be a positive operating disconnect switch (also referred to as a knife switch) in the welding lead side of the current path. Do not operate this switch unless specifically directed by the diver. When the diver calls for a change the tender must confirm that change to the diver. Never assume that because contact one time is not harmful similar contact at other times will also be harmless. Changes can occur changing the effects of the contact. Develop a procedure to check the integrity of the electrical circuit before starting each operation. SEE SAFETY AND OPERATING REFERENCES 1, 2, AND 3.

SAFETY AND OPERATING INSTRUCTIONS

UNDERWATER WELDING AND CUTTING CAN CAUSE FIRES AND EXPLOSIONS



All precautions necessary for cutting and welding in underwater work are presented for an object that may contain flammable and/or explosive ingredients. Prior to cutting or welding in a closed compartment, a means must be provided to permit escape of all entrapped gases. Having the diver work from the highest point down could reduce the possibility of trapping gas mixtures that could lead to explosions. Before each dive, torches using spark arrestors must be checked to ensure the arrestor is clean and in place. Removal of the spark arrestor or any torch parts creates a safety hazard which could cause internal burning of the torch. Most underwater cutting operations use oxygen; therefore, all safety precautions concerning the use of oxygen must be observed. Oxygen itself is not flammable, but the presence of pure oxygen drastically increases the speed and force by which burning takes place. Always refer to oxygen by its full name "oxygen", and not by the word "air". Never allow oil, grease, or other petroleum-based substances to come in contact with cylinder valves, regulators, hoses or any other part of the oxygen supply system. Do not let an arc, cutting rod, or flame touch any part of the oxygen supply system. Chain or secure cylinders to an object such as a cylinder cart, wall, workbench, post, etc. When moving cylinders, always be sure that valve protection caps are securely in place. Never stand in front or behind a regulator when opening the cylinder valve. Always stand so the cylinder is between you and the regulator. Never use compressed air instead of oxygen. Keep oxygen cylinders away from electrical connections. SEE SAFETY AND OPERATING REFERENCES 1, 2, 3, 4, AND 5.

SAFETY AND OPERATING REFERENCES

1. CODE OF FEDERAL REGULATIONS, (OSHA), SECTION 29 PART 1910.101, 251,252,253,254,401, 410,420,427,430,440, AND 441.U.S. GOVERNMENT PRINTING OFFICE, WASHINGTON, DC 20402 ANSI Z49.1 SAFETY IN WELDING AND CUTTING.
2. AWS F4.1 RECOMMENDED SAFE PRACTICES FOR WELDING AND CUTTING CONTAINERS.
3. THE AMERICAN WELDING SOCIETY, 550 NW LEJEUNE RD., P.O.BOX 351040, MIAMI FL. 33135 ADC CONSENSUS STANDARDS FOR COMMERCIAL DIVING OPERATIONS
4. ASSOCIATION OF DIVING CONTRACTORS, INC. 2611 FM 1960 W., SUITE F-204 HOUSTON, TX 77068 NFPA 51B FIRE PREVENTION IN CUTTING AND WELDING PROCESSES.
5. NATIONAL FIRE PROTECTION ASSOCIATION, BATTERY PARK, QUINCY MA 02269 CSA STANDARD W117.2.
6. CANADIAN STANDARDS ASSOCIATION, 178 REXDALE BLVD., REXNALE ONTARIO, CANADA M9W 1R3

SECTION 3: PROCESS VARIABLES

Working with electrical power always presents hazards and requires caution, especially with underwater work. Electrical power used in underwater cutting and welding can be very hazardous, so the warnings and safety precautions in this manual must be observed. The life and safety of the diver and the welfare of the support vessel depend on strict observance of all safety regulations. If the basic protective measures in this manual are strictly observed and supplemented by proper safeguards and reasonable care, underwater cutting and welding can be done safely. Only use approved equipment and carefully follow the manufacturers' operating instructions.



CAUTION

It is important that safety precautions be obeyed for topside equipment also. Failure, explosion, or fire resulting from equipment aboard the support vessel could endanger the lives of the operators below the surface.

No work of any kind should be permitted on the surface over the area in which the diver will be working. The diver's work circle/area should have a radius of at least equal the working depth.

All precautions necessary for cutting and welding in underwater work are presented for an object that may contain flammable and/or explosive ingredients. Prior to cutting or welding in a closed compartment or corner, provide a means to permit escape of any entrapped gases.

Establishing recommended procedures for all situations that can arise working underwater is impossible. When unforeseen conditions occur, individual ingenuity and imagination combined with a knowledge of cutting and welding basics must be used to complete the performed task. Therefore, only qualified diving personal, trained in underwater cutting and welding, should perform underwater jobs.

POWER SOURCES

Treat any power source as a potential hazard and observe the safety recommendations below.

- Install power sources by experienced personnel using only approved wiring diagrams.
- The preferred power sources for underwater cutting and welding are DC welding generators or rectifiers of at least 300 amps capacity. However, some operations require 400 amps and over.
- Connect two or more machines in parallel to get the needed power. Check the manufacturer's instructions for proper hookup.
- In emergency situations, a 200 amp DC generator may be used, but is not recommended.
- An AC power supply is not recommended. It is not as safe as DC. Maintaining an arc is easier with DC power.
- Be sure that the power source is in good mechanical and electrical condition and there is no excess flashing on the commutators. Normal outdoor protection should be provided.
- Put the power source on a dry, wooden mat or some other insulating material, if possible.

SAFETY AND OPERATING INSTRUCTIONS

- Ground the power source(s) to the support vessel. Do not ground the welding generator terminals to the frame of the welder.
- Be sure that all electrical connections are tight.
- The ground lead cable should be tight on the work.
- Underwater welding and oxygen/arc cutting are done with DCEN (straight polarity). When DCEP (reversed polarity) is used, electrolysis causes rapid deterioration of any exposed metallic parts in the electrode holder or cutting torch.

NOTE

The Arcwater process uses reverse polarity.

- The correct polarity is important. Achieve straight polarity by connecting the negative (-) lead of the welding machine to the torch and the positive (+) lead to the ground clamp. The ground clamp should be on a clean area of the work. This will give a good electrical connection.

SAFETY SWITCHES

- There must be a positive operating disconnect switch (also referred to as a knife switch) in the welding-lead side of the current path. This protects the diver by letting the current flow only when the diver is actually cutting or welding. A double pole, single throw switch that protects both the welding and ground leads is even safer.
- Figure 1 shows a typical setup. The switch must be fully enclosed and the operating handle extended through a slot.
- It is important, especially when single pole switches are used, that the switch is not being shunted out. Avoid this by making certain that the cable between the welding machine and the switch is fully insulated along its entire length. Inspect the cable insulation regularly.
- Other types of automatic safety switches can be used to provide positive control of the current in the circuit. Whatever type of switch is used, it should be located where the person, communicating with the diver, can operate the switch and oversee its operation at all times.



CAUTION

It is important that the switch is not operated unless specifically directed by the diver, and when so directed, the tender should confirm each change to the diver.

ELECTRICAL CABLES

- Use only approved, extra flexible, and completely insulated cables.
- The proper cable size for a job depends on the total length of the circuit. Use 2/0 cable when the total length of cable, including the electrode and ground leads, exceeds 300 ft. (90 m). If the total length exceeds 400 ft. (122 m), two or more 1/0 (105,000 cm), or 2/0 cables may be paralleled to reduce resistance. Occasionally 3/0 (168,000 cm) cable may be desired for extreme depths.
- For underwater welding a “whip lead” of 1/0 cable may be attached to the electrode holder, enabling the diver to maneuver the electrode holder while welding.

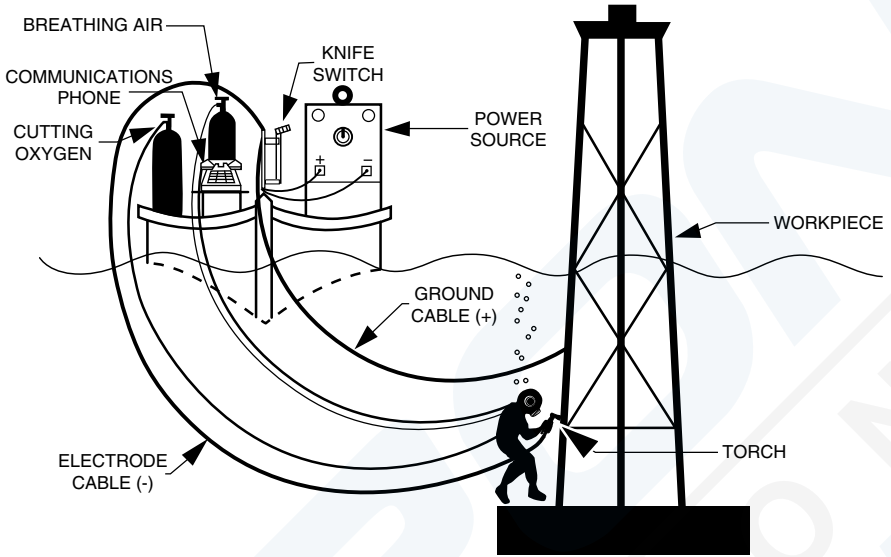

Figure 1: Typical Setup

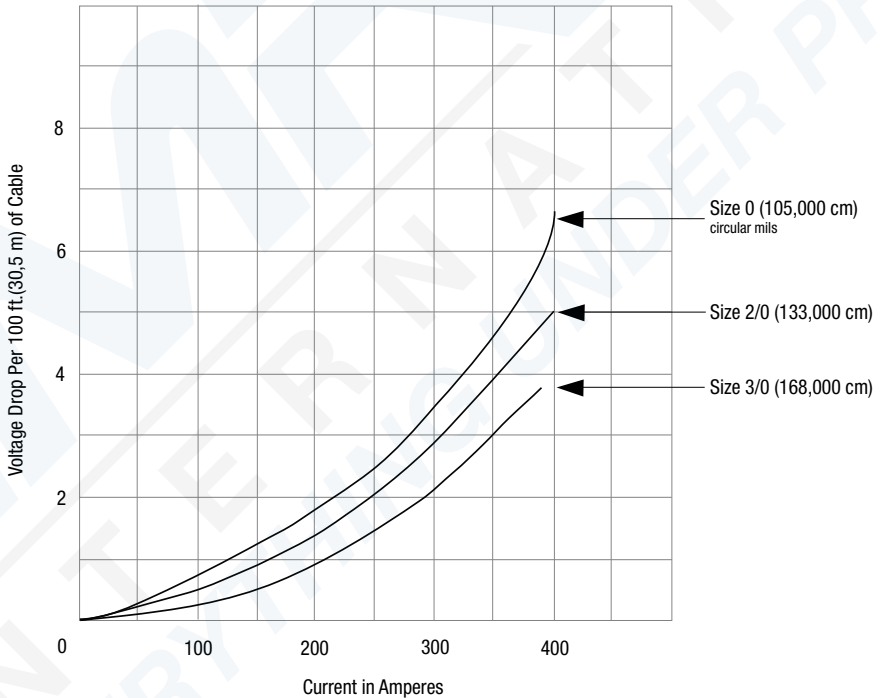

Figure 2: Voltage Drops for Cable Size/Length

SAFETY AND OPERATING INSTRUCTIONS

- Cables should be 50 ft. (15 m) lengths minimum, complete with both male and female connectors.
- Voltage drops for cables are shown in Figure 2. The effect of contact resistance is not shown in the table, but it can be kept to a minimum by making sure that all connections are tight and insulated.
- A poorly insulated connector is a hazard because it causes current leaks and rapid deterioration of the copper cable by electrolysis.
- All parts of submerged cables must be fully insulated. A tight, final wrapping with rubber tape is recommended to insulate and waterproof underwater connections.
- Inspect cables and connections for damaged insulation before starting. Repair or replace defective cables. With portable machines, lay the primary cables separately and away from the welding supply cable.
- Keep welding cables in storage - dry and free from grease, if possible.
- Hang cables above deck. If this is not possible, protect the cables to prevent undue damage or breakdown of insulation.
- The life of any cable is increased by proper coiling when not in use, and by minimizing its exposure to oil. Connect ground cables close to the work area and place so that the diver's body is never between the electrode and the ground side of the welding circuit.



WARNING

Never assume that because electrical contact at one time is not harmful, similar contact at other times will also be harmless. Changes can occur which would change the effects of the contact.

TORCHES AND ELECTRODE HOLDERS

- Only use torches and electrode holders designed for underwater applications.
- Before starting any underwater operation, torches and electrode holders should be inspected for worn or damaged parts or faulty insulation. Repair or replace damaged parts.
- After each day's use, rinse the torch or electrode holder in fresh water and dry to maintain proper operating efficiency.



WARNING

Before each dive, check torches using spark arrestors to ensure the arrestor is clear and in place. Removal of the spark arrestor creates a safety hazard which could cause injury and/or destroy the torch.

OXYGEN USE

Store oxygen used in the oxygen/arc cutting process in high pressure oxygen cylinders and deliver at reduced pressures to the oxygen/arc torch. Safety precautions must be taken in storing, handling, and using oxygen. When proper precautions are followed oxygen can be used with complete safety and confidence. The following precautions must be observed by all personnel involved in underwater oxygen/arc cutting operations.

- Only approved equipment should be used; it should be examined and tested prior to use.
- Place the tender assigned to the care and control of the gas supply where they have quick access to the valves in case of emergency.
- Frequently inspect the complete oxygen system for leaks while in use.

**WARNING**

Never mix oil and oxygen. Oxygen may react violently with oil or grease, take every precaution to prevent contact. Do not handle oxygen cylinders, valves, regulators, hose, and other apparatus and fittings with oily hands or gloves, or greasy materials. Do not transport or store them where they can become filled with oil or grease.

- Never use compressed air instead of oxygen.
- Never allow a jet of oxygen to strike an oily surface, greasy clothes, or a fuel tank that has contained a flammable substance.
- Use soapy water made with grease-free soap to test piping system or other equipment.
- NEVER EMPLOY FLAMES TO DETECT LEAKS.
- Tape the power cable and oxygen hose together approximately every 3.3 ft. (1 m).
- If the diver works from the highest point down, this reduces the possibility of explosions from trapped gas mixtures.
- A single cylinder of oxygen is enough if the cutting operation is limited. Manifolder cylinders are best to minimize cylinder changes. If cylinders are used, the torch should be turned off during changes.

SAFETY AND OPERATING INSTRUCTIONS

DIVER SAFETY

It is extremely important that the diver's clothing gives maximum protection against electrical shock and eye injuries from electric arcs. In addition to the safety precautions given in other parts of this manual, the following rules about dress should be observed.

- The diver must be clothed in diving dress, fully insulating them from all electrical circuits. Provide the diver the maximum protection with a dry suit with a dry helmet. The suit should be in good condition and free of tears. Insulate the diver's head from the helmet by wearing a cloth skull cap or "beanie". Insulate the helmet chin button and the exhaust valve button.
- The standard wet suit with a face mask may be used for cutting or welding operations if it is in good condition. Use of rubber or rubberized canvas gloves is mandatory.
- The diver should regularly inspect the helmet and all other metallic parts of the gear for signs of deterioration. Diving gear must always be in good condition.
- The diver should wear a welding shield fitted with welding lenses for the water conditions at the site.
- Equip the diver with a reliable communications system.
- The diver must stay clear of all hoses and avoid too much slack in the lines. Keep all hoses away from the cutting and welding operation.
- The diver must never become a part of the secondary circuit by putting themselves between the electrode and the ground with "current on". They must not have any part of their body in contact with the grounded work when a bare portion of an electrode could touch their body completing the electrical circuit. Never point the electrode toward the diver.
- Do not touch the helmet with the electrode, any uninsulated part of the electrode holder, or torch.
- Do not touch the work with the metal helmet or any metallic part of the diver's dress.
- Before cutting, the diver should check that air hoses and diving suit will not be in the path of the slag from the cutting operation.
- The diver must avoid cutting in the overhead position since the falling molten material may seriously damage the diving suit and air hoses.
- The current must be off at all times except when the diver is actually cutting or welding.
- After the electrode is used, the diver must not remove the stub until they signal "current off" and has had this request confirmed by the tender. The person on the tender must not give their confirmation until they have actually broken the circuit.
- Remove the electrode before taking the torch or electrode holder under water or returning it to the surface.

SECTION 4: UNDERWATER CUTTING

4.01 OXYGEN/ARC CUTTING PROCESS

Some underwater cutting uses the oxygen/arc process, which depends on the rapid oxidation of metals. An electric arc applies heat between the base metal and the tip of the cutting electrode. Place the tubular steel electrode at the cut line to rapidly heat the metal. A high velocity oxygen jet is directed through the tube to the heated spot and the melting operation proceeds. The oxygen jet also blows away the molten metal.

Oxygen/arc cutting does not effectively cut non-oxidizable materials, such as corrosion and/or oxidation resistant steels, and some non-ferrous metals such as copper base alloys. This process also does not work well on materials that have heavy coatings of paint, marine growth, or other non-conductive materials; more suitable processes exist for those materials.

The two types of tubular steel electrodes for oxygen/arc cutting in the Arcair Underwater Product Line are sold under the trademarks Sea-Cut® and Tuff-Cote®.

A. Sea-Cut Electrodes

- Blue in color; one size only
- Waterproof (See Section 7.01)
- Not flux coated

Part No.	Diameter	Length	Bore Hole Size
42-059-007	5/16" (7,9 mm)	14" (35,6 mm)	0.113" (2,9 mm)

B. Tuff-Cote Electrodes

- White in color; one size only
- Waterproof
- Flux coated (See Section 7.02)

Part No.	Diameter	Length	Bore Hole Size
42-059-008	5/16" (7,9 mm)	14" (35,6 mm)	0.113" (2,9 mm)

4.02 EXOTHERMIC CUTTING PROCESS

Similar to the oxygen/arc process, exothermic cutting uses rapid oxidation of metals as the primary means of cutting. An electric arc between the electrode and the workpiece melts a portion of the workpiece. Simultaneously, a jet of oxygen is forced down the hollow center of the electrode. The cutting is performed by an exothermic reaction between the workpiece and oxygen jet. This is the most efficient method of cutting oxidizable metals.

Most non-ferrous metals and non-metallic materials do not oxidize as readily; therefore, the oxygen/arc method is ineffective. The Sea-Jet® and Sea Dragon™ electrodes do not require that the base metal be oxidizable or need an electric arc to burn the electrode. The exothermic reaction takes place at the end of the electrode. Once an arc is struck, the rod burns continuously without electric current. The electrode and the oxygen create heat to melt the material that is blown away by the oxygen stream.

A. Sea-Jet Electrodes

- Red in color; one size only

B. Sea Dragon Electrodes

- Orange in color; one size only

Part No.	Diameter	Length
42-066-006	3/8" (9,5 mm)	18" (45,7 cm)
42-075-005		

These cutting electrodes make operations possible that cannot be done with standard oxy/arc cutting electrodes. They will cut non-ferrous as well as ferrous materials and oxidizable metals. They will also melt concrete, rocks, and burn through barnacles and other sea growth. These electrodes are 3/8" (9,5 mm) in diameter and 18" (45,8 cm) long and they are intended for use with the Arcair Sea Torch® Combination Torch (Part No. 14-050-126).

The current range for the Sea-Jet and Sea Dragon electrodes is 0-350 amps. For most applications, when electrical power is used throughout the cutting operation, 300 amps gives the best cutting rates.

Electrical current is supplied by a DC constant current welding power supply on straight polarity (electrode negative). Using a 12-volt battery is another method of igniting these electrodes. A battery supplies enough energy to ignite the electrode which will burn without further power. These rods burn as long as oxygen is flowing. Oxygen passes through the electrode. When this high energy jet combines with the burning electrode, it melts, burns, or spalls the material.

The recommended oxygen pressure for the Sea-Jet and Sea Dragon electrodes is generally 75-100 psi (4.9 - 7.0 kg/cm²) over bottom pressure. Higher pressures will cut thick sections faster. Refer to the following table in Section 4.03.

To start cutting on a conductive workpiece place the electrode against the workpiece. Turn the oxygen and power on and strike an arc. Cutting will start immediately. Drag the electrode along the workpiece at about a 45° angle.

NOTE

If the workpiece is not conductive, a strike plate must be used.

The Arcair Sea-Jet and Sea Dragon electrodes have several advantages to offer the user:

- Consistent quality
- Stable arc
- Ease of operator handling
- Higher visibility under water during cutting because of the bright glow at the tip of the electrode. This glow also helps the operator maintain the proper arc length.

4.03 OXYGEN AND AMPERAGE

A fairly wide range of oxygen flow provides satisfactory cutting. However, using less volume of oxygen slows cutting and increases diver fatigue. The table gives guidelines for oxygen pressure versus plate thickness.

Plate Thickness	Oxygen Pressure psi* (kg/cm ²)
Up to 1" (25,4 mm)	100 (7,0)
Up to 1 1/2" (38,1 mm)	125 (8,8)
Up to 3" (76,2 mm)	150 (10,5)

* For kPa multiply psi x 6.895

NOTE

Supply table values are pressure at the torch. They do not include the pressure drop for the length of hose or pressure needed to compensate for water depth. To compute the extra pressure in psi, multiply depth in feet by 0.45. (To find added kg/cm² multiply depth in meters by 0.105.) For example, cutting 3/4" (19 mm) plate at a depth of 100 ft. (30,47 m):

Calculation For Depth

$$100 \text{ ft.} \times 0.45 = 45 \text{ psi}$$

$$30,47 \text{ m} \times 0.105 = 3,2 \text{ kg/cm}^2$$

Total Oxygen Pressure

$$45 + 100 \text{ (Table Value)} = 145 \text{ psi}$$

$$3,2 + 7.0 \text{ (Table Value)} = 10,2 \text{ kg/cm}^2$$

Compensation for the pressure drop in hose lengths varies depending on the inside hose diameter. Single line, two braid, oxygen hose is recommended. For work done in medium or deeper depths, 1/4" (6,35 mm) ID hose is recommended. For each 100 ft. of hose, add 5-10 psi. Use hose made for oxygen service.

Amperage requirements are listed in the below table.

Electrode Brand	Current Amps
Sea-Cut	300 - 400
Tuff-Cote	300 - 350
Sea-Jet	0 - 400

4.04 OPERATING TECHNIQUES

Firmly insert the electrode so that it presses against the rubber seal in the torch head. The techniques for cutting thick and thin plates differ slightly and are discussed below.

A. Cutting Thick Plates 1/4" (6,4 mm) and Over

To begin the cut, hold the electrode perpendicular to the surface and place the electrode tip against the work. Open the oxygen valve and call for "current on". If necessary, slightly withdraw the electrode and tap against the work to start the arc. Use a drag technique to advance the cut. Hold the electrode at a 45° to 60° drag angle - the burning rod tip is held pointing away from the direction of travel. The angle varies with the steel thickness. When using Sea-Cut or Tuff-Cote electrodes, touch the rod tip to the work. With the Sea-Jet and Sea Dragon electrode, maintain an arc length. Move the electrode in two directions:

1. Inward to make up for electrode burn-off
2. Forward to advance the cut

Back flare, visible even in murky water, indicates an incomplete cut. If this happens, go back a slight distance into the cut and start again.



When the electrode has been used, always signal "CURRENT OFF" before changing electrodes. Keep the torch in cutting position until the tender acknowledges "CURRENT OFF". This safety precaution is mandatory regardless of the electrode type or current setting.

B. Cutting Thin Plate - Under 1/4" (6,4 mm)

Cutting thin plates differs from thick plates. The electrode tip barely touches the plate surface as it advances along the cut. Hold the electrode at a 30° angle leading away from the direction of travel.

Use another method in poor visibility. Hold the electrode pointing in the direction of the cut and incline toward the plate at a 20° angle. This exposes more surface area and makes cutting easier.

NOTE

Clean metal cuts better than dirty or corroded metal. Materials covered with mill scale and one or two thin coats of paint can be cut. Materials covered with heavy coats of non-conductive materials can be cut without being cleaned using the Sea-Jet or Sea Dragon electrode. Clean the work of heavy non-conductive coatings if Sea-Cut or Tuff-Cote electrodes are used.

C. Piercing Holes in Steel Plate

Piercing a hole in steel is easy using the oxygen/arc method. Touch the plate lightly where you want the hole. Open the oxygen valve and call for "current on". Hold the electrode still for a moment;

withdraw the electrode, if necessary, to get it to start burning. Push the electrode slowly into the hole until the plate is pierced. By this method 3" (76,2 mm) thick steel plate has been pierced in six seconds.

D. Cutting Cast Iron and Non-Ferrous Metals

When cutting materials that do not oxidize easily, underwater oxygen/arc cutting becomes a melting process. The drag technique used for cutting steel does not work when cutting thick cast iron or non-ferrous metals. The diver must move the tip of the electrode in and out of the cut because melting only takes place at the arc. For cutting thin plates, manipulating the electrode is not necessary and the operation is the same as used for thin steel plates. Since the cutting is done by melting, use up all the available current to the maximum current capacity for the torch and/or electrode.

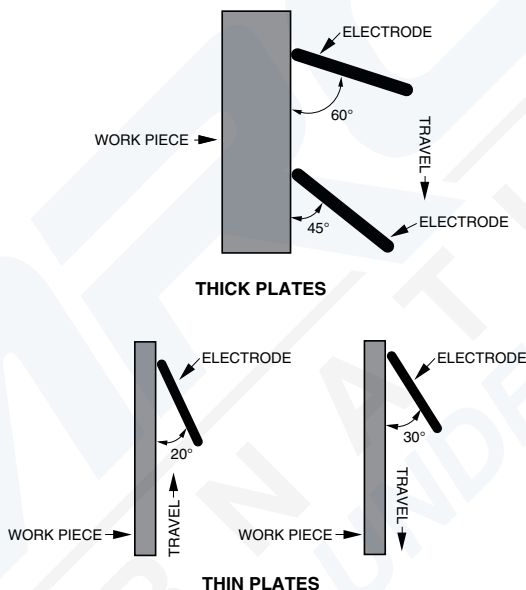

Figure 3: Proper Torch to Workpiece Cutting Angles

4.05 UNDERWATER COMBINATION TORCH (WELDING/CUTTING)

The Arcair Sea Torch Combination Torch (Part No. 14-050-124) is used for underwater welding and cutting (see Page 5-20).

Torch Features:

- One piece body construction which prevents oxygen leaks which can occur with torches having mechanical connections between the head and handle. The design permits the oxygen valve and lever to be put in different positions by the loosening, rotating, and retightening of set screws.
- An oxygen valve for controlling oxygen flow.

SAFETY AND OPERATING INSTRUCTIONS

- It is fully insulated electrically for safety and protects the metal parts from electrolysis.
- It has a 10 ft. (3,04 m) cable which can be disconnected from the torch.
- It is orange for high visibility to the diver, weighs 2 lbs. (0,91 kg), and is designed to fit a gloved hand.
- The torch has a tapered collet which, when compressed by the collet ring, brings the surface of an electrode in contact for the entire length of the collet. This minimizes arcing between the collet and the electrode.
- It has a single external collet taper which causes the collet ring to force the collet and electrode against a seal. This ensures a positive seal of the oxygen flow and eliminates corrosion of the current carrying parts. The solid grip on the electrode and the increased contact area reduces accidental arcing in the head.
- The torch has a spark arrestor with an easily removed and replaceable screen. A ball check valve is located in the torch handle for added protection.



WARNING

The torch must be maintained with all components properly assembled to avoid damage and safety hazards. Spark arrestors must be left in place or burning and/or explosion inside the torch handle can result. Torch failure and/or injury to the operator is possible if any of the three items below are modified or removed: 94-071-003, Ball Check Valve; 94-305-009, Spark Arrestor; 94-940-098, Washer. (See Section 10.01)

Electrical leakage from the torch can shock the operator if any of the four items listed below are modified or removed: 94-071-003, Ball Check Valve; 94-940-098, Washer; 94-433-177, Cable Tip Insulator; 94-150-003, Loctite 242 Thread Sealant. (See Section 10.01)

NOTE

If the ball check valve is removed from the torch, be sure that the special Washer (Part No. 94-940-098) is placed properly, since it contains a seat for the ball check valve. (See Section 10.01)

NOTE

If the electrical cable is repaired or replaced, the Cable Tip Insulator (Part No. 94-150-003 above) must be replaced to ensure electrical integrity, and Loctite 242 Thread Sealant must be put on the threads to prevent loosening of the connection.

SECTION 5: UNDERWATER WELDING

5.01 UNDERWATER DRY WELDING

The process requires that the water around the work area be removed. This is normally done by using a chamber with controlled atmosphere and pressure. The dry process is costly, but produces welds which are generally equal in quality to welds made above water.

5.02 UNDERWATER WET WELDING

The process is performed without a pressurized enclosure and uses the shielded metal arc process, also known as "stick" welding. To produce the weld, form an electric arc between a flux-covered metal electrode and the work. The heat from the arc melts the parent metal, core wire, and some of the flux covering. Other parts of the flux covering decomposes into gases that shield the molten metal from contamination by the surrounding atmosphere (Figure 4).

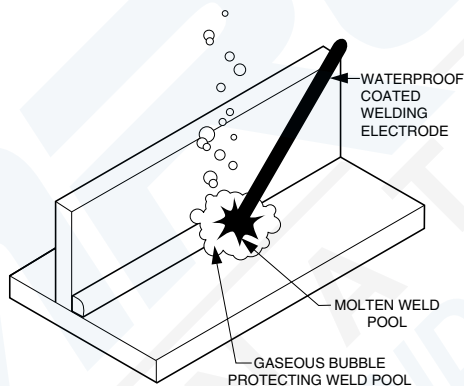

Figure 4: Underwater "Wet" Welding

The versatility, speed, and lower cost of wet welding makes the process highly desirable for underwater welding. It is done without special fixtures. The repair needs are greatest in salt water areas; the success of wet welding is better in higher salinity water so the wet welding process works ideally. Dissolved salts in the water increase its electrolytic qualities thus making a hotter arc and more efficient welding operation.

Be cautious in certain adverse conditions that make wet welding more difficult:

- Clean dirty surfaces before welding. Free the weld joint of thick paint, rust, or marine growth.
- When using multiple pass welding, clean slag from each bead before depositing the next pass.
- Avoid an unstable weld platform, especially when working near the surface in rough water. Provide the diver with the most stable welding platform possible.
- Avoid Poor Fit. A $\frac{1}{16}$ " (1,59 mm) gap is the maximum allowed. If the gap is bigger than that, use the "feeding in" technique - hold the electrode in the gap long enough to allow the weld

SAFETY AND OPERATING INSTRUCTIONS

metal to feed into the gap. One advantage is the metal tends to enter the gap versus running out, as in the air. This method requires considerable skill.

- Extremely low visibility interferes with seeing the groove to follow. To overcome, give the diver a definite groove to follow.

5.03 WELDING TECHNIQUE

The weld metal is deposited in a series of beads or strings. When fillet welding, these beads have about the same leg size as the electrode diameter. Thus, a single pass with a $\frac{3}{16}$ " (4,76 mm) electrode results in a $\frac{3}{16}$ " fillet weld. This technique has been used to make groove welds that conform to the AWS Underwater Welding Specification D3.6-83, Type B welds. When making a groove weld, be aware that as the groove is filled, the stringer welds become harder to make. You are filling the joint and losing the edges used as a guide to make the final stringer passes.

Maintain constant contact between the electrode and work. The diver buries the rod in the puddle while dragging it along the weld path. This removes the skill required to keep a gap between the work and the welding electrode tip because the electrodes developed for underwater welding have a flux covering which burns away at a slower rate than the core wire. Thus, the flux covering extends beyond the end of the core wire and gives an automatic arc length. The protective sleeve of coating also keeps the end of the core wire off of the parent metal, plus helps prevent sticking the electrode to the work.

The technique also enables the fabrication of strong welded joints. For example, under test conditions at several Naval facilities, underwater fillet welds made in mild steel plates have consistently developed over 80% of the tensile strength and 50% of the ductility of similar welds made in air. The hardening causes lower ductility, a result of the drastic quenching action of the surrounding water.

A. "Drag" Welding Procedure

1. Thoroughly clean the welding surfaces.
2. Make sure the safety switch is open.
3. Set the welding generator for proper current delivery to match the electrode being used. This current is higher than the topside current for the same electrode since the surrounding water absorbs the heat rapidly.
4. Place the striking end of the electrode against the work and angle the electrode approximately 30° to the weld line. The angle may vary from 15° to 40° , depending on the electrode used and the personal preferences of the diver.

Electrode Size in(mm)	Part No.	Position	Current Amperes	Time for 12"(305 mm) Burnoff Seconds
1/8 (3,2)	42-024-002	H	140 - 170	36 - 47
		V		
		OH	140 - 155	42 - 48
5/32 (3,97)	42-984-004	H	170 - 210	44 - 56
		V		
		OH	170 - 190	50 - 56
3/16 (4,76)	42-034-007	H	220 - 260	50 - 59
		V		
		OH	190 - 210	61 - 66

5. Call for "current on". The arc starts when the tender closes the safety switch. If the arc does not start, tap or scrape the end of the electrode against the work until the arc starts. Once the arc has started, exert enough pressure against the work to allow the electrode to consume itself.
6. Hold the original angle between the electrode and weld line by moving the hand toward the surface being welded. Do not hold an arc as in topside welding. Simply keep the electrode in contact with the work. Run straight beads. Do not weave. This method is an advantage in poor visibility conditions, which make it difficult to hold an arc.
7. Call for "current off" when the electrode is used. The tender must open the safety switch and keep it open while the diver changes electrodes. Keep the electrode in the welding position after the weld is finished, until the tender has verified that the current is off.
8. Before starting to weld with a new electrode, clean the end of the previous bead. The deposit from the new electrode should slightly overlap the previous deposit. If a second pass is added, thoroughly clean the previous weld.
9. Do not call for "current on" until the new electrode is in position ready for welding. In general, weld so that the bubbles from the weld do not interfere with visibility. For example, the diver should weld toward rather than away from oneself.



WARNING

When the electrode has been used, signal "current off" before changing electrodes. This must ALWAYS be done. Be sure to hold the torch in position until the tender acknowledges "current off". This safety precaution is mandatory.

B. Overhead Position

The same technique is followed, except the current range for overhead welding is very narrow. Welds made using currents outside this range result in very poor deposits or no deposit at all. Skillful divers can use a 35° to 55° angle of the electrode to the work in the overhead position and a steady rate of progress. This requires a lot of skill, but produces fillet welds without convexity and undercutting, as found when using the self-consuming technique. If the diver does not have this skill, then the self-consuming technique is recommended.



CAUTION

The diver must minimize welding in the overhead position since the falling molten material may seriously damage the diving suit and air hoses.

C. Vertical Position Welding

Vertical welds use the drag technique and progress in the vertical down direction - start at the top of the area to be welded and go down.

5.04 UNDERWATER WELDING EQUIPMENT

The Arcair Underwater product line includes torches, electrode holders, and electrodes for underwater wet welding.

- A. The Sea-Stinger® II Electrode Holder (Part No. 14-050-128) is used for underwater wet welding only and uses the Sea-Weld Electrodes. The holder meets the requirements of being insulated and durable, permits easy changing of electrodes, is lightweight, and used for underwater welding only. To use:
1. Twist the head in a counterclockwise direction
 2. Insert the electrode
 3. Twist clockwise to lock
- B. The Arcair Sea Torch Combination Torch can be used for cutting (See Page 4-15) and welding. To weld underwater using this torch, the collet must be changed to match the size of the welding electrode being used.
- C. The Arcair Arcwater® II Torch can be used for gouging, cutting, or welding. To weld with this torch, match the collet to the size of the electrode. For more details see Section 4.04.
- D. The Sea-Weld® Electrode product line includes round, steel, flux coated electrodes for wet welding. They are coated with a yellow waterproof coating and available in three sizes:

Part No.	Diameter	Length
42-024-002	1/8"(3,2 mm)	14"(356 mm)
42-984-004	5/32"(4,97 mm)	
42-034-007	3/16"(4,76 mm)	

Since wet flux coatings deteriorate, and water is absorbed into the flux, a waterproof coating is necessary. The integrity of underwater electrodes must be maintained. If the waterproof coating leaks, water forced through the coating will turn to steam and blow off the coating when the arc is struck. The tip of the welding electrodes are coated with the waterproofing. This feature improves the resistance to leaks until the arc is started. To start the arc, lightly tap the tip of the electrode against the workpiece. The grip ends should be free of coatings to prevent the coating from interfering with electrical contact between the electrodes and the holder. If any coating is visible on the grip end remove it before using the electrode. (See Sections 7.01 and 7.02)

SECTION 6: ARCWATER PROCESS

6.01 PRINCIPLES OF THE PROCESS

The patented Arcwater process was developed to perform underwater gouging and cutting. The process consists of striking an arc between a carbon-graphite, copper-coated, waterproofed electrode and the workpiece. A high pressure jet of water, which exits the torch through an orifice under the electrode, pushes away molten metal from the workpiece. A clean surface remains for welding (Figure 5).

NOTE

The arcwater process uses reverse polarity.

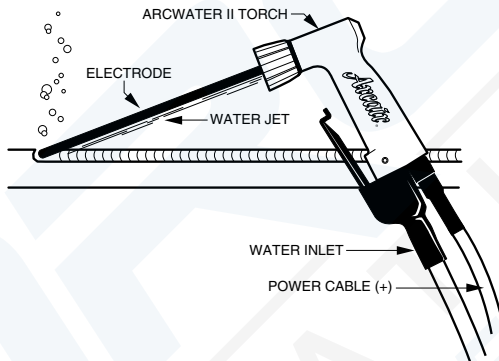

Figure 5: Arcwater Process

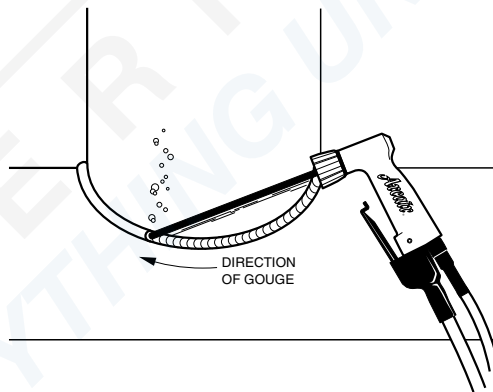

Figure 6: Removal of Fillet Weld

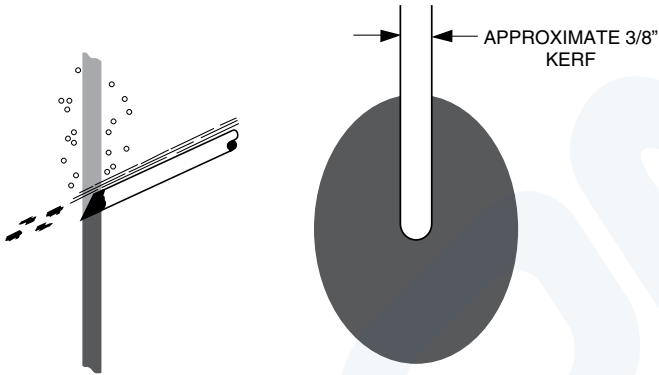

Figure 7: Removal of Structures

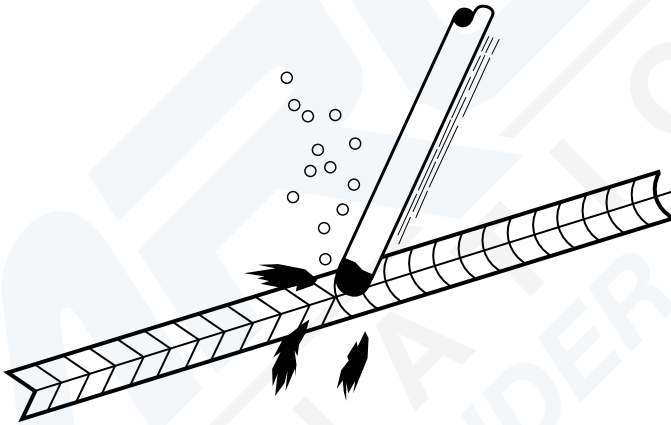

Figure 8: Crack Repair

6.02 APPLICATIONS

- Remove defective welds (Figure 6).
- Remove unwanted structures but may not be practical for metal over one inch thick (Figure 7).
- Cracked butt or seam welds can be grooved for weld repair (Figure 8).
- It can be used on most metals found in ships and underwater structures.

6.03 PROCEDURE

When satisfied that the equipment is in good order, insert the bare copper end of the electrode in the torch, and tighten the collet ring. Then tap or rub the arc end of the electrode lightly against the workpiece. When in position, call for water pressure and then signal the tender to turn on the power or "current on".

A. Groove Plate or Gouge Out Cracks

The depth of the groove varies with torch angle, travel, and amperage. Use a 40° electrode-to-work angle for gouging and weld removal with the water jet under the electrode. Move the torch forward fast enough to maintain the arc and the desired groove depth. Do not cut deeper than 1/4" (6,4 mm) in a single pass.

B. Severing Materials

When cutting, angle the torch 75° with the water jet under the electrode. Take care to prevent molten metal from blowing back at the diver. Once a hole is pierced in the metal, use a sawing motion to advance the cut. Useful applications include cutting materials in confined areas or below the mud line. Since this process does not use oxygen, the problem of creating gas pockets and underwater explosions is reduced.

When the diver has finished, or has used the electrode to within 1.5" (37,1 mm) of the torch, signal the tender to shut "power off" or "current off", and ask that the water pressure be turned off. Only then does the diver loosen the collet ring and remove the electrode stub.

6.04 OPERATION

To use, connect the power cable to a direct current power source. A direct current constant voltage power source can be used if the open circuit voltage is 60 volts or more. The amperage range is 350-500 amperes DC-REVERSE POLARITY - this is the opposite of the DC straight polarity used in oxygen/arc cutting.

NOTE

This process uses REVERSE POLARITY (ELECTRODE POSITIVE). With reverse polarity the torch is connected to the positive lug of the welding machine.

Water pressure at the torch must be 90 psi (6,3 kg/cm²). The water flow rate is at least 3.5 gallons (13,25 L) per minute.

6.05 ARCWATER EQUIPMENT

The Arcwater II Torch (Part No. 14-050-027) is a special design, electrically insulated and completely waterproofed except in the collet area. This means that only the collet is exposed to electrolysis. This fact increases the life of the torch. It is small and well balanced to minimize diver fatigue.

This torch is designed to use Arcwater Electrodes 5/16" x 9" (7,9 mm x 229 mm). They are copper coated and waterproofed. (Part No. 42-059-006). The copper coating improves the conductivity of the electrode.

The waterproof coating protects and insulates the electrode under water. The electrode is waterproofed, except for the end, which is put in the torch. The waterproofing at the arc end of the electrode can be removed by scratching the electrode against the workpiece. Be careful, when starting a new electrode, not to apply enough pressure to break the electrode.

6.06 OPERATING DATA

A) Gouging Carbon Steels

Electrode Diameter	Average Groove Width/ Depth		Water Pressure Range		Amperage Range
	in(mm)	in (mm)	psi	kg/cm ²	DCRP
5/16 (7,94)	7/16 (11,13)	3/8 (9,53)	90 - 110	6,33 - 7,73	375 - 400

* Groove depth determined by speed of travel, other parameters remain the same.

B) Cutting Steel Pipe

The table below suggests settings used for cutting steel pipe. Actual settings may vary.

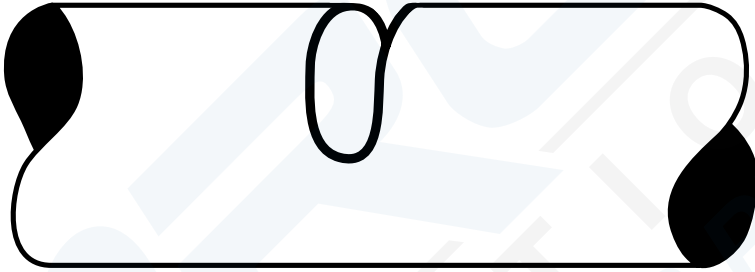

Wall Thickness	Average per Minute	Water Pressure Range		Amperage Range For Cutting
		in(mm)	in(mm)	
0.1875 (4,76)	22.0 (559)	90 - 110	6.33 - 7.73	475 - 525
0.250 (6,35)	16.0 (406)			
0.375 (9,53)	12.4 (315)			
0.500 (12,70)	8.4 (213)			
0.625 (15,88)	4.2 (106)			
0.750 (19,05)	1.4 (35)			

NOTE

The settings for stainless steel are similar to carbon steel. Non-ferrous materials, such as bronze and brass, can be cut with above operating conditions if copper content is 80% or less. If copper content is higher than 80% switch cables to run on Straight Polarity (Electrode Negative).

SECTION 7: UNDERWATER ELECTRODES

7.01 WATERPROOF COATING

NOTE

All Arcair underwater electrodes have waterproof coatings.

Since flux coatings deteriorate when immersed in water, waterproof coatings are necessary. The integrity of underwater electrodes must be maintained; therefore, any leaking or water forced into the flux causes steam and blow off when the arc is struck. Plus the coating provides electrical insulation. The tips must be free of coating to expose enough bare rod for easy starting of the arc. The grip ends must be free of coating also to not interfere with electrical contact between electrodes and holder.



WARNING

Only perform electrode changing or tightening in the holder when no current exists in the circuit.

7.02 FLUX COATING

Flux coating of electrodes serves a number of purposes:

- To promote easy starting and maintenance of the arc
- To form and maintain a protective shield around the arc. The coating must be consumed at a slower rate than the core. It must be concentrically consumed to permit restarting the arc.
- It must generate gases to form a bubble around the arc
- It prevents arcing from the side of the electrode

NOTE

Avoid slag formation on the material being cut since slag deposits in the groove prevent further oxidation.

7.03 ELECTRODE DATA

Brand	Part No.	Color	Flux	Diameter in (mm)	Length in (cm)	Amp	Bore Hole in (mm)	Applications
Sea-Cut	42-059-007	Blue	No	5/16 (7,9)	14 (35,6)	300-400	0.113 (2,9)	Oxygen/Arc Cutting
Tuff-Cote	42-059-008	White	Yes	5/16 (7,9)	14 (35,6)	300-400	0.113 (2,9)	
Sea-Jet	42-066-006	Red	No	3/8 (9,5)	18 (45,7)	0-350	0.125 (3,2)	Exothermic Cutting
Sea Dragon	42-075-005	Orange		3/8 (9,5)	18 (45,7)			
Sea-Weld	42-024-002	Yellow	Yes	1/8 (3,2)	14 (35,6)	150-180	N/A	Wet Welding
	42-984-004			5/32 (3,97)	14 (35,6)	170-210		
	42-034-007			3/16 (4,76)	14 (35,6)	190-230		
Arcwater	42-059-006	White	No	5/16 (7,9)	9 (22,9)	350-450		Arcwater Gouging

SECTION 8: SEA-PAK® 400A POWER SYSTEM

The Sea-Pak 400A Power System is a complete underwater cutting and welding power and gas supply unit.

The Power Supply is diesel-driven, 400 amperes, and DC constant current, with a 100% duty cycle at 40 arc volts. For power tools or auxiliary lighting, a 3 KVA, 120-volt, single-phase AC 50/60 Hertz outlet is provided.

The five-station oxygen manifold has space for five oxygen cylinders. Individual shutoff valves and a two-stage, high-pressure, high-flow manifold regulator complete the oxygen supply system.

The Sea-Pak Complete Package (Catalog No. 73-101-024) includes the Arcair Sea Torch Combination Torch, the Arcair Sea-Stinger II Underwater Welding Electrode Holder, 200 ft. of heavy duty neoprene power and ground cable, 200 ft. of double-braided oxygen hose with fittings, and a heavy duty tool box.

The Sea-Pak System Complete Package is designed for maximum safety featuring a two pole, single-throw knife switch across the power and ground cables and a power supply designed that the polarity cannot be changed except by changing the cable leads.

The complete unit is ruggedly constructed and has all of the equipment and gear necessary for the welding or cutting. The frame is designed for easy transport by forklift, or corner lugs provide for crane lift.



Figure 9: Sea-Pak

SECTION 9: MAINTENANCE

9.01 SEA TORCH DISASSEMBLY

A. Disassembly of Head Area

1. Unscrew and remove the Collet Ring Assembly; the Collet Chuck will fall out of torch.
2. Remove the Washer from the outside of the Torch Handle by using a small object such as a paper clip. Insert in the paper clip under the washer and pull it out of the torch.

NOTE

Washer fits tightly, if it is damaged during removal, replace it before using the torch.

3. Use a screwdriver to remove the Blowback Retainer. This also frees the Spark Arrestor from the torch.

B. Disassembly of Oxygen Valve Area

4. Loosen the two Set Screws in the handle to remove the Oxygen Valve and Lever Assembly.
5. Remove the Washer from the handle by using a small wire or paper clip.

NOTE

Washer fits tightly, if it is damaged during removal, replace it before using the torch.

6. After the Washer is removed the Ball Check Valve will fall out of torch.

NOTE

When replacing the Washer, face the end with the bevel on the hole in the torch toward the Ball Check Valve.

7. Remove Pin from the Valve Assembly to release the Valve Lever Assembly from the Oxygen Valve.

C. Replacement of Damaged Cable

8. To replace damaged cable, unscrew the Cable Assembly at the base of the handle to remove from the Torch Handle.



CAUTION

Do not damage the shrink tube on the Cable Assembly when removing it. This could cause electrical leaks at the end of the Cable Assembly.

9. When Cable Assembly is removed, the cable Tip Insulator can be removed.

To assemble the head area, reverse the above instructions in Steps 1-9 and observe the "NOTES". When replacing the Cable Assembly, apply Loctite 242 compound to the threads so the connection will not come loose.

9.02 ARCWATER II DISASSEMBLY

Refer to steps in Section 9.01A for head disassembly.

1. Loosen the two Set Screws in the handle to remove the Water Valve and Lever Assembly.
2. Remove the Washer from the handle by using a small wire or paper clip.

NOTE

Washer fits tightly, if it is damaged during removal, replace it before using the torch.

3. Remove Pin from the Valve Assembly to release the Valve Lever Assembly from the Water Valve.
4. Replace damaged cable, unscrew the Cable Assembly at the base of the handle to remove from the Torch Handle.



CAUTION

Do not damage the shrink tube on the Cable Assembly when removing it. This could cause electrical leaks at that end of the Cable Assembly.

5. When Cable Assembly is removed the Cable Tip Insulator.

To assemble, reverse steps 1-9 in Section 9.01.

9.03 SEA-STINGER II ELECTRODE HOLDER DISASSEMBLY

1. Unscrew and remove the Head.
2. Unscrew Cap from head.
3. Remove Plug from Handle.
4. Remove Set Screw from Handle to release the Cable Assembly from the handle and the Body from the cable assembly.

To assemble, reverse the above steps to reassemble the torch. When replacing the Set Screw be sure that the Body is aligned so that the Set Screw goes in the hole in the body and tightens against the Cable Assembly.

SECTION 10: PARTS LISTING

10.01 SEA TORCH

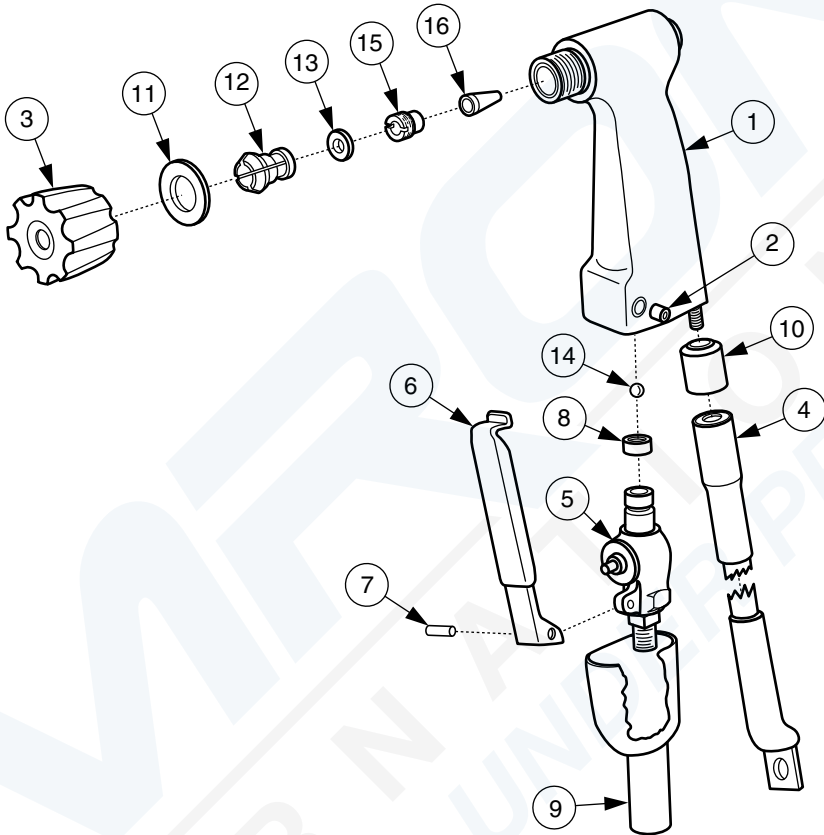

Item No.	Part No.	Description
1	94-370-157	Torch Handle
2	97-373-001	Set Screw (2 per)
3	94-168-018	Collet Ring
4	96-130-234	Cable Assembly
5	94-921-057	Oxygen Valve
6	94-476-061	Valve Lever
8	94-940-098	Washer
9	94-105-013	Valve Boot

Item No.	Part No.	Description
10	94-433-177	Cable Tip Insulator
11	94-940-097	Washer
12	94-158-043	5/16" Collet Chuck
13	94-940-099	Washer
14	94-071-003	Ball Check Valve
15	94-695-037	Blowback Retainer
16	94-305-009	Spark Arrestor

10.02 ARCWATER II TORCH

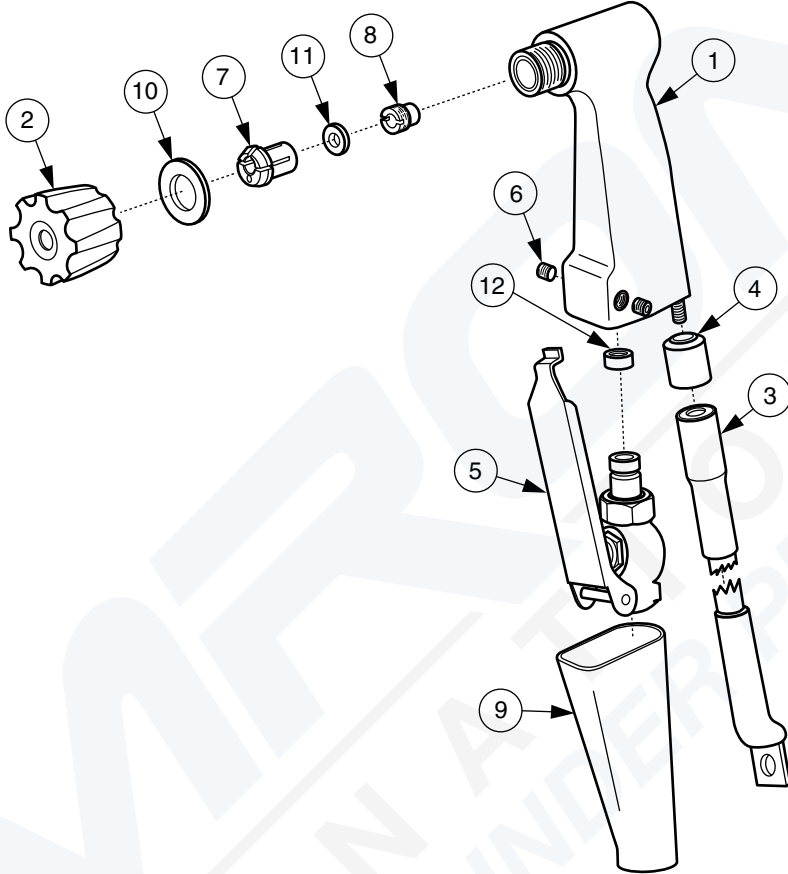

Item No.	Part No.	Description
1	94-370-174	Torch Handle
2	94-168-018	Collet Ring
3	96-130-234	Cable Assembly
4	94-433-177	Tip Insulator
5	94-921-063	Valve & Lever Assembly
6	97-373-001	Set Screw (2 per)

Item No.	Part No.	Description
7	94-158-049	Collet Chuck Assembly
8	94-695-037	Blowback Retainer
9	94-105-021	Boot
10	94-940-097	Washer
11	94-940-105	Washer
12	94-940-098	Washer

10.03 SEA-STINGER II ELECTRODE HOLDER

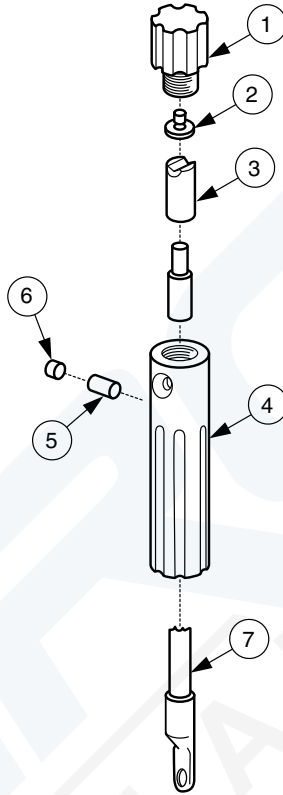

Item No.	Part No.	Description
1	94-378-351	Head
2	94-131-067	Cap
3	94-103-228	Body
4	94-370-175	Handle
5	97-373-006	Set Screw
6	94-638-086	Plug
7	96-130-298	Cable Assembly

SECTION 11: STATEMENT OF WARRANTY

LIMITED WARRANTY: THERMADYNE® warrants that its products will be free of defects in workmanship or material. Should any failure to conform to this warranty appear within the time period applicable to the THERMADYNE products as stated below, THERMADYNE shall, upon notification thereof and substantiation that the product has been stored, installed, operated, and maintained in accordance with THERMADYNE's specifications, instructions, recommendations and recognized standard industry practice, and not subject to misuse, repair, neglect, alteration, or accident, correct such defects by suitable repair or replacement, at THERMADYNE's sole option, of any components or parts of the product determined by THERMADYNE to be defective.

THIS WARRANTY IS EXCLUSIVE AND IS IN LIEU OF ALL OTHER WARRANTIES, EXPRESS OR IMPLIED, INCLUDING ANY WARRANTY OF MERCHANTABILITY OR FITNESS FOR A PARTICULAR PURPOSE.

LIMITATION OF LIABILITY: THERMADYNE shall not under any circumstances be liable for special or consequential damages, such as, but not limited to, damage or loss of purchased or replacement goods, or claims of customers of distributor (hereinafter the "Purchaser") for service interruption. The remedies of the Purchaser set forth herein are exclusive and the liability of THERMADYNE with respect to any contract, or anything done in connection therewith such as the performance or breach thereof, or from the manufacture, sale, delivery, resale, or use of any goods covered by or furnished by THERMADYNE whether arising out of contract, negligence, strict tort, or under any warranty, or otherwise, shall not, except as expressly provided herein, exceed the price of the goods upon which such liability is based.

THIS WARRANTY BECOMES INVALID IF REPLACEMENT PARTS OR ACCESSORIES ARE USED WHICH MAY IMPAIR THE SAFETY OR PERFORMANCE OF ANY THERMADYNE PRODUCT.

THIS WARRANTY IS INVALID IF THE PRODUCT IS SOLD BY NON-AUTHORIZED PERSONS.

This warranty is effective for the time stated in the Warranty Schedule beginning on the date that the authorized distributor delivers the products to the Purchaser.

Warranty repairs or replacement claims under this limited warranty must be submitted by an authorized THERMADYNE repair facility within thirty (30) days of the repair. No transportation costs of any kind will be paid under this warranty. Transportation charges to send products to an authorized warranty repair facility shall be the responsibility of the Purchaser. All returned goods shall be at the Purchaser's risk and expense. This warranty supersedes all previous THERMADYNE warranties.

U.S. Customer Care: ARCAIR® / STOODY® / THERMAL ARC® / THERMAL DYNAMICS® / TWECO® / VICTOR® **800-426-1888 / FAX 800-535-0557**
 FIREPOWER® **800-858-4232 / FAX 800-535-0557** TDC AUTOMATION **866-279-2628 / FAX 800-535-0557**
 TURBOTORCH® **800-238-0282 / FAX 800-535-0557** VICTOR MEDICAL **800-382-8187 / FAX 800-535-0557**
 VICTOR SPECIALTY PRODUCTS **800-569-0547 / FAX 800-535-0557**

Canada Customer Care: 905-827-4515 / FAX 800-588-1714 • International Customer Care: 905-827-9777 / FAX 905-827-9797
CIGWELD Customer Care: 1300-654-674 / FAX 613+ 9474-7391 • www.thermadyne.com



A Global Cutting & Welding Market Leader™

THE AMERICAS

Denton, TX USA
U.S. Customer Care
 Ph: (1) 800-426-1888
 Fax: (1) 800-535-0557

Miami, FL USA
Sales Office, Latin America
 Ph: (1) 954-727-8371
 Fax: (1) 954-727-8376

Oakville, Ontario, Canada
Canada Customer Care
 Ph: (1) 905-827-4515
 Fax: (1) 800-588-1714

International Customer Care
 Ph: (1) 905-827-9777
 Fax: (1) 905-827-9797

EUROPE

Chorley, United Kingdom
Customer Care
 Ph: (44) 1257-261755
 Fax: (44) 1257-224800

Milan, Italy
Customer Care
 Ph: (39) 0236546801
 Fax: (39) 0236546840

ASIA/PACIFIC

Cikarang, Indonesia
Customer Care
 Ph: 62 21+ 8983-0011 / 0012
 Fax: 62 21+ 893-0067

Osaka, Japan
Sales Office
 Ph: 816-4809-8411
 Fax: 816-4809-8412

Melbourne, Australia
Australia Customer Care
 Ph: 1300-654-674
 Fax: 613+ 9474-7391

International
 Ph: 613+ 9474-7508
 Fax: 613+ 9474-7488

Rawang, Malaysia
Customer Care
 Ph: 603+ 6092-2388
 Fax: 603+ 6092-1085

Shanghai, China
Sales Office
 Ph: 86-21-64072626
 Fax: 86-21-64483032

Singapore
Sales Office
 Ph: 65+ 6832-8066
 Fax: 65+ 6763-5812