



## **AVOX SYSTEMS™ OXYGEN INHALATORS**

- ❖ 803139 Series Pressur Vak II Inhalator
- ❖ 801238 Series Overboard Discharge Inhalator
- ❖ 803600 Series Single Hose Inhalator

# TABLE OF CONTENTS

# Section

<b>General Information</b>	<b>1</b>
Introduction	1.1
<b>Care and Cleaning</b>	<b>2</b>
General Inspection	2.1
Minimum Care Requirements	2.2
Standard Cleaning Procedures	2.3
Disinfecting	2.4
Storage and Preservation	2.5
<b>Hose Assembly Maintenance</b>	<b>3</b>
Hose Assembly Component Parts Installation	3.1
<b>Demand Regulator Maintenance</b>	<b>4</b>
Demand Regulator Maintenance Instructions	4.1
<b>Exhaust Regulator Maintenance</b>	<b>5</b>
Exhaust Regulator Maintenance Instructions	5.1
<b>Pressur Vak II Inhalator</b>	<b>6</b>
Assembly / Disassembly of Pressur Vak II	6.1
Attaching Face Seal to Manifold Assembly	6.2
Detaching Face Seal from Manifold Assembly	6.3
Regulators to Manifold Installation	6.4
Pressur Vak II Inhalator Parts Drawing	6.5
Pressur Vak II Inhalator Parts Listing	6.6
<b>Retrofit Kit</b>	<b>7</b>
Avox Retrofit Kit (Part No. 803200-XX)	7.1
Retrofit Kit – Disassembly of 801238 Face Piece Assy.	7.2
<b>801238 Series Overboard Discharge Inhalator</b>	<b>8</b>
General Information	8.1
801238 Series Parts Drawing	8.2
801238 Series Parts Listing	8.3
<b>803600 Series Single Hose Inhalator</b>	<b>9</b>
General Information	9.1
<b>Troubleshooting</b>	<b>10</b>
<b>Inhalation / Exhalation Performance Chart</b>	<b>11</b>
Inhalation Performance Chart	11.1
Exhalation Performance Chart	11.2
<b>Repair Log</b>	<b>12</b>
<b>Technical Assistance</b>	<b>13</b>

**WARNING!**

Read user manual prior to operating inhalator to ensure user safety and proper use.

**WARNING!**

To prevent a vacuum from occurring in the oral nasal cavity and possible user injury, proper gas supply/exhaust settings must be established and supply/exhaust valves must remain on while mask is donned and in use.

**WARNING!**

Remove mask **BEFORE** turning off gas supply or injury can result.

**WARNING!**

Any service or overhaul performed on this apparatus shall be done only by those facilities experienced in, or by personnel knowledgeable in oxygen equipment. All procedures described in this manual shall be performed in an area free of oil, grease, flammable solvents or other combustible materials. Such materials, as well as dust, lint and fine metal filings are all potential combustibles which might, when exposed to oxygen under pressure, ignite and result in an explosion and/or fire.

**1.1. Introduction**

1. This manual delineates operation, maintenance, and replaceable parts information for the following Avox Oxygen Inhalators:
  - Pressur Vak II– Series 803139 Inhalator with overboard discharge
  - 801238 Series Inhalator with overboard discharge
  - 803600 Series Single Hose Inhalator without overboard discharge
  - 803200 Retrofit Kit which converts the 801238 Series Inhalator to the newer Pressur Vak II Series 803139 Inhalator.
2. The Avox Oxygen Inhalators are designed to administer breathing oxygen or mixed breathing media to a diver or patient in a hyperbaric chamber environment.

### 1.1. Introduction (continued)

3. The use of Pressur Vak II or the Duo-Seal Inhalator with overboard discharge eliminates oxygen buildup or contamination of the chamber environment by dumping the exhaled gases directly out of the chamber.
4. The demand regulator assembly provides breathing gas on demand (inhalation). The regulator is designed to operate with a constant inlet pressure of 65 - 125 psi over chamber pressure. You can set the over bottom pressure to the pressure that meets your system breathing requirement. Setting the over bottom pressure over 100 psig may result in labored breathing resistance. Under normal conditions, the regulator will provide adequate flow rates at acceptable breathing resistance. The demand regulator can be adjusted to free-flow by turning the control knob clockwise until desired free flow is achieved.
5. The vacuum regulator on the inhalators with overboard discharge allows the exhaled gases to be carried to outside the chamber. The vacuum of the exhaled gas is a direct function of the differential pressure of the chamber and the ambient environment. For chamber depths over 60 F.S.W., a secondary vacuum regulator must be installed. It is recommended to use a negative spring biased back pressure differential regulator such as the Tescom 26-2912-282A. This type of regulator is recommended but not required for systems operating under 60 F.S.W.
6. It is recommended that a shut off valve be incorporated between the outside of the chamber and the exhaust valve on the mask so the vacuum in the chamber can be shut off.
7. Both the BIBS supply and exhaust valves must be turned on prior to placing the inhalator on the user's face and must remain open until the inhalator is removed to prevent a vacuum from occurring in the oral nasal cavity.
8. It may be desirable to use a single high pressure regulator located at the high pressure source to increase the pressure to the second stage regulator on the inhalator. This may also be desirable when operating a multiple number of masks.

**Note:** The regulator must be sized properly to maintain an outlet pressure within 65 to 125 psi range over bottom pressure, while providing proper flow rates for the number of masks and source pressure.

### 2.1 General Inspection

1. General inspection of this life support equipment should be performed before and after each extended dive program.
2. Inspect all hoses, face seals, and gaskets for excessive wear.
3. Inspect all “soft” parts, especially diaphragms, for wear, rips, tears or punctures.
4. Inspect regulator “tilt valves” for any debris or corrosion lodged below tilt valve.
5. Inspect threaded fittings for burrs and cross-threading.
6. Inspect for missing or damaged hardware, like screws, washers and clamps.
7. Inspect all metal parts for burrs, nicks, dents, cracks, and corrosion.

### 2.2 Minimum Care Requirements

1. External cleaning and drying of the complete assembly should be performed after each extended treatment. See Cleaning Procedures.
  - **Pressur Vak II**, separate the face seal from the manifold assembly after each session. Leaving the face seal connected to the system will result in deterioration of the face seal and corrosion of the manifold quick-disconnect system. Separate the manifold assembly from the regulator assemblies on a regular basis. Inspect the inside of the regulators for corrosion and debris. Clean or disinfect and dry regulators and manifold completely before re-assembly.
  - **801238 and 803600** masks should be periodically disassembled and cleaned and dried.
  - Store the mask properly when not in use. See Storage Procedures.
  - Replace diaphragms, O-rings, and face seal straps yearly or as required.

**Caution!** Do not leave mask assembly connected to chamber ports for extended periods after a dive without cleaning and drying the unit. Moisture build up within the unit will lead to corrosion after a period of time.

**2.3 Standard Cleaning Procedures**

1. The information in this manual should be used as a guideline only. Every company should have their own procedures in place for cleaning and /or disinfecting safety equipment used in oxygen and breathing environments!
2. **After Each Use** – Clean facemasks with nonionic detergent such as “Ivory Liquid” and warm water (110°F maximum). Rinse with clear water and dry completely before using or storing. Wipe and clean entire remaining assembly as above and dry completely before using or storing. (Take care that water does not enter the regulator assembly openings).
3. **Every 6 Months** – Disassemble entire assembly, manifold, regulators, hoses, diaphragms. See Section for Assembly/Disassembly Procedures. Clean all metal and non-metal parts with nonionic detergent. Rinse with clear water and dry completely before storing or using.
4. You may also sponge external parts and components with a 70 percent solution of Ethyl Isopropyl alcohol, or SaniZide-Plus. Allow to completely dry for a minimum of two hours before storing or using.
5. An oxygen compatible lubricant, such as Christo-Lube, is recommended for use as a lubricant. It is recommended to periodically lubricate all the moving parts such as hose connection threads, manifold threads, etc.

**WARNING!**

**Alcohol is a flammable! Use caution when handling.**

### 2.4 Disinfecting

SaniZide-Plus can be used for disinfecting the Avox Inhalators and found on Amron's website at [www.amronintl.com](http://www.amronintl.com). Use per manufacturer's instructions.

Avox Systems, Inc. or Amron International, Inc. is not responsible for damage to equipment or improper cleaning. Each person or entity is responsible for their own procedures for disinfecting oxygen breathing masks.

### 2.5 Storage and Preservation

1. After extended treatment, the entire assembly should be disassembled, cleaned, dried, and reassembled then stored in an air tight sealed plastic bag until the next use.
2. Remove the complete mask assembly from the chamber when not in use. If required to store mask in the chamber, ensure that the mask is clean and completely dry and stored in an air tight plastic bag.
3. After each dive, the Pressur Vak II face seal should be disconnected from the manifold assembly. Clean and dry the face seal completely and store in an air tight plastic bag until the next treatment.

**Caution!** Do not leave the mask assembly inside the chamber for extended periods without cleaning, drying and proper storing.

## 3.1. Hose Assembly Component Parts Installation

1. Slide grommets (E-5), onto hoses (E-3 & E-4). Three grommets are recommended per 10 foot hose assembly. Distribute grommets uniformly over entire length of hoses.
2. Insert hose plug (E-7) to end of exhaust hose (E-4). Secure hose clamp (E-8).
3. Insert gasket (E-2) into demand hose assembly (E-3).
4. Attach demand hose to demand regulator assembly (C-1). Follow instructions paragraph 4.1 through 5.1 for completion of hose assembly.
5. It is important to attach the demand hose to the demand regulator (E-3) first.
6. Verify that the gasket (E-2) is inserted into the nut on the demand hose.
7. Screw hose nut to demand regulator assembly (C-1) and tighten moderately with wrench, a quarter or half turn after finger tight.
8. Push hose assembly (E-4) onto exhaust regulator (C-2) until stem of regulator is fully inserted into the hose.
9. Attach the hose clamp (E-8) around the hose at the top end, so the clamp firmly grasps the regulator stem. Tighten the clamp.
10. Attach the demand quick disconnect (F-2) to the demand hose assembly hose plug (E-6).
11. Attach the quick disconnect (F-1) to the exhaust hose plug (E-7).

**NOTE:** Optional (F-3) Dummy Plug for Exhaust Quick Disconnect (see parts list).

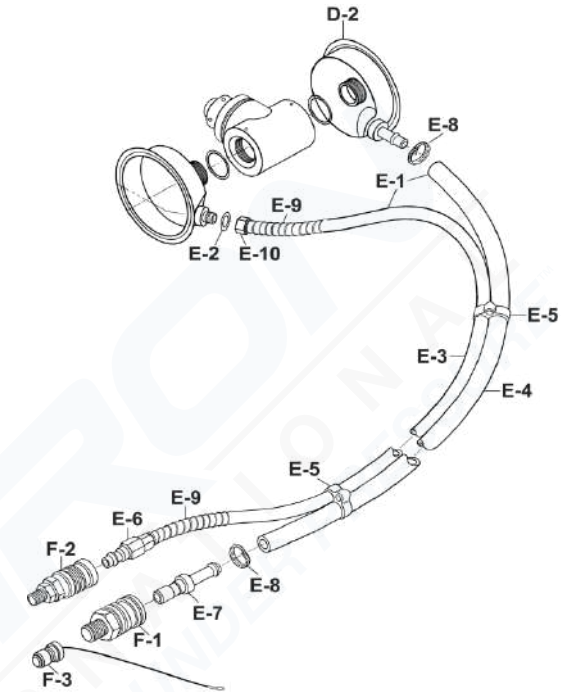

## 4.1 Demand Regulator Maintenance (C-1)

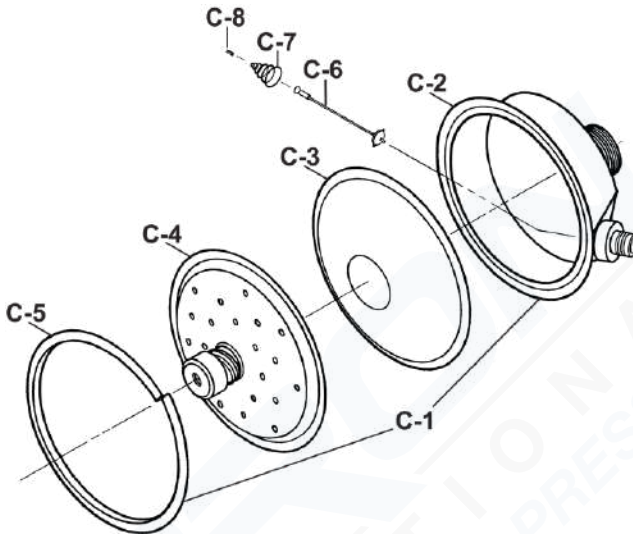

1. Remove clamp (C-5) from Regulator Assembly by spreading and removing. Lift cover (C-4).
2. Lift diaphragm (C-3) out of case assembly (C-2).
3. The spring, stem, clamp and case assembly parts (C-2, 6, 7, 8) are not available as spare parts. If these parts become damaged or need replacing, contact Amron International, Inc. for repair or replacement of regulator assembly.
4. Inspect the diaphragm for tears or rips and be sure the diaphragm is free of wrinkles and bulges. Replace if necessary. Diaphragm should be replaced on a yearly basis as a minimum.
5. During reassembly the arrow on the diaphragm must be facing the regulator cover and the metal disc on the diaphragm must point to the hose connection (inlet). Diaphragm must be positioned so the tilt valve stem ball rides on the metal disc.
6. Replace cover (C-4) and clamp assembly.

**Note:** Demand Regulator Valve Assembly (Items C-6, C-7, C-8) are not available as spare parts. If these items become damaged you must purchase the 80095601 Regulator Case Assembly with valve or complete Demand Regulator Assembly 800954-01.

## 5.1 Exhaust Regulator Maintenance (D-1)

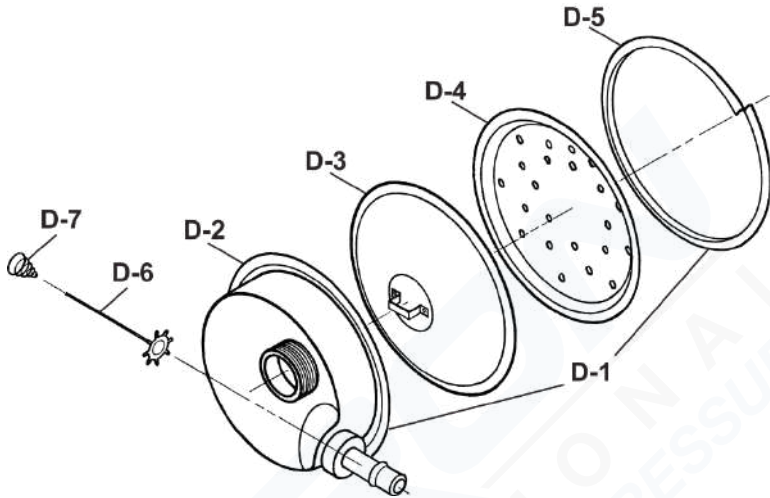

1. Remove cover (D-4) by spreading and removing clamp (D-5).
2. Lift diaphragm and stem guide assembly (D-3) out of case assembly (D-2). Care should be taken to guide the stem assembly carefully out of the stem guide on the diaphragm.
3. Inspect diaphragm for any cuts, tears, wear or bulges. Replace if necessary. Diaphragm should be replaced on a yearly basis as a minimum.
4. To remove valve assembly (D-6 & D-7) from case assembly (D-2), gently compress spring (D-7) and carefully remove entire spring and stem assembly.
5. When reassembling the tilt valve stem in the exhaust regulator the stem must be positioned between the diaphragm and tilt valve retainer bracket. The arrow on the diaphragm must point toward the inlet.
6. Replace Diaphragm, cover and clamp assemblies.

### 6.1 Assembly / Disassembly of Pressur Vak II

1. The Pressur Vak II face seal is designed to attach and detach with ease from the manifold assembly via a quick disconnect arrangement. This allows each person to have their own face seal and reduces infections associated with multi-user type systems. This quick disconnect arrangement also facilitates convenient cleaning and disinfecting of the mask.
2. The face seal assembly is available in five (5) sizes for a comfortable fit and to ensure proper seal to prevent leakage past the mask to face interface. The harness assembly is designed to hold the face seal securely and does not loosen once securely positioned.

### 6.2 Attaching Face Seal to Manifold Assembly

1. Align face seal front opening to manifold quick disconnect
2. Place thumb inside face seal and push the quick release inner flange down, while pushing face seal onto the manifold quick disconnect.
3. Face seal will “lock on” the manifold assembly.
4. To verify face seal is securely attached to manifold, carefully attempt to pull face seal assembly away from the manifold.

### 6.3 Detaching Face Seal from Manifold Assembly

1. Align face seal front opening to manifold quick disconnect
2. Place thumb inside face seal and push the quick release inner flange down, while pushing face seal onto the manifold quick disconnect.
3. Face seal will “lock on” the manifold assembly.
4. To verify face seal is securely attached to manifold, carefully attempt to pull face seal assembly away from the manifold.
5. Place thumb inside face seal and push the quick release inner flange down, while pulling slightly on the face seal outer edges.
6. Manifold should disengage from face seal with little or no pressure exerted on the face seal.



### 6.4 Regulators to Manifold Installation

1. Install exhaust and demand regulators to manifold assembly as follows:
2. Position the two O-rings (B-2) on Demand Regulator (C-1) and Exhaust Regulator (D-1).
3. Screw regulator (C-1) into manifold (B-1).
4. Screw regulator (D-1) into opposite side of manifold (B-1).

**Important:**

**Do not forget to place O-rings (B-2), one on each regulator, before attaching regulators.**

5. Insert a "cotter pin" or a small locking pin tool into the small tightening holes located at top of the manifold (See B-4).

**Note:** There are two holes (one in the outer manifold case and one in the inner swivel assembly). Align holes and insert pin to prevent inner swivel from turning while tightening regulators.

6. Exert a small amount of pressure on the tool while rotating the regulator onto the manifold until you feel the pin drop into the second hole which is located inside the manifold. Hold this position firmly and tighten the regulator
7. Ensure that regulators are tightened correctly on manifold, twist the regulator that you have just installed while exerting outward pressure on the regulator. If regulator comes loose, you have not properly tightened the regulator to the manifold.
8. Follow the above procedure for both the exhaust and the demand regulators when installing and disassembling of the regulators to manifold assembly.

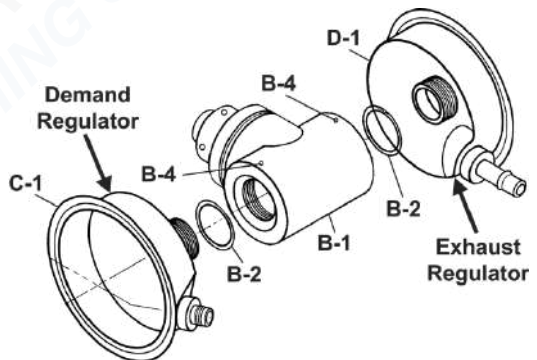

## Section 6

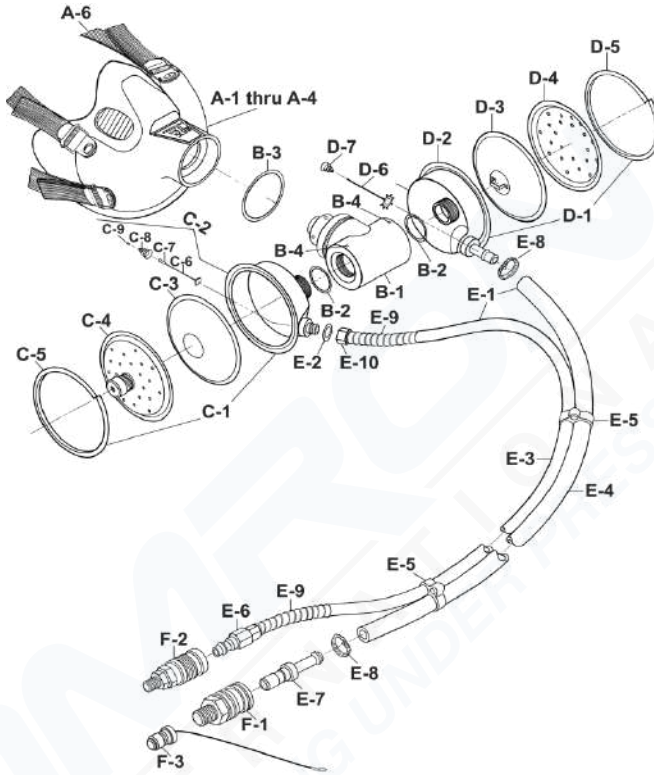

## 803139 SERIES PRESSUR VAK II INHALATOR

### 6.5 Pressur Vak II Inhalator Parts Drawing



**Not Shown**

**Face Seal with Microphone Assembly 803152(XX) M**

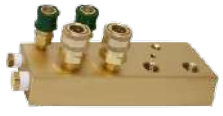
Headnet/Harness Assembly:	Brass Blanking Plug:	BIBS Manifold:
<p>Headnet with light weight polyester netting and Velcro straps. Provides a snug fit around the upper portion of the head which evenly distributes the weight of the mask and regulators. An alternative to the 803115-01 head strap assembly provided with the Pressur Vak II Inhalator.</p>  <p>Order No. 460-0001-01</p>	<p>Inserts in the exhaust quick disconnect. Stops exhaust flow from chamber when mask is disconnected from manifold.</p>  <p>Order No. B-6QDP</p>	<p>Easy to use Brass manifold available in 2 or 4 port versions. Includes demand and exhaust ports.</p>  <p>2 Port 8000-002 4 Port 8000-004 shown</p>

**6.6 Pressur Vak II Inhalator Parts Listing**

<b>Item</b>	<b>Part Number</b>	<b>Description</b>	<b>Material</b>
A-1 thru A-4	803152- (size)	Face seal Assembly with elastic strap assy. (05=X-Sm, 01=Sm, 02=Med, 03=Lg, 04=X Lg)	Polysulfone (Hard Shell) Silicone Rubber Soft Seal
A-6	803115-01	Head Strap (Elastic)	Elastic
	00-5401	Screw w/o-ring (inside face seal) (4)	Stainless Steel
	834-12	Capped T-Nut (face seal) (4)	Stainless Steel 303
	801430-03	Buckle Bar (face seal) (4)	CRCQ Low Carbon Steel
<b>B-1</b>	<b>803100-01</b>	<b>Manifold Assembly Housing &amp; Plunger, Ball Lock Ball, Spring and Pins</b>	<b>Noryl SE-1 Teflon coated Alum. Alloy Stainless Steel</b>
B-2	18062-00	O-Ring, Manifold to Regulators (2)	Silicone Rubber
B-3	21506-01	O-Ring, Manifold to Face seal (1)	Silicone Rubber
B-4	N/A	Illustration Only	
<b>C-1</b>	<b>800954-01</b>	<b>Demand Regulator Assembly</b>	<b>See Lower Assembly</b>
C-2	800956-01	Case Assembly, Includes C-6,7,8,9	Stainless Steel 316
C-3	26004-01	Diaphragm, Demand Regulator	Neoprene & natural rubber blend
C-4	801276-00	Cover, Demand Regulator	Stainless Steel 316
C-5	26010-01	Clamp, Regulator Cover	Stainless Steel 316
C-6,7	Not Available	Valve Stem & Spring	Stainless Steel 316
C8,9	Not Available	Valve Clamp & Bearing Spring	Stainless Steel 302
<b>D-1</b>	<b>801274-00</b>	<b>Exhaust Regulator Assembly</b>	<b>See Lower Assembly</b>
D-2	801275-00	Case Assembly, Exhaust Regulator	Stainless Steel 316
D-3	801272-00	Diaphragm & Stem Guide Assembly	Stainless Steel & Buna N
D-4	100003027	Cover, Exhaust Regulator	Stainless Steel 316
D-5	26010-01	Clamp, Regulator Cover	Stainless Steel 316
D-6	800963-00	Valve, Exhalation	Stainless Steel 316
D-7	13796-00	Spring, Exhalation Valve	Stainless Steel 316
<b>E-1</b>	<b>803166-10</b>	<b>Dual Hose Assy., with F-1 &amp; F-2</b>	<b>See Lower Assembly</b>
E-2	2827-49	Gasket, Demand Hose	Teflon

## Section 6

## 803139 SERIES PRESSUR VAK II INHALATOR

### 6.6 Pressur Vak II Inhalator Parts Listing (continued)

Item	Part Number	Description	Material
E-3	26037-10	Demand Hose Assembly, 10 Ft. Includes E-2 & F-2 Cleaned for Oxygen Breathing	I.D. 1/4" O.D. 1/2" Working Pressure 400 psi Burst Pressure 2000 psi Inner Tube Nitrile, Black Braid Single Fiber Cover Neoprene
E-4	59719-10	Exhaust Hose Assembly, 10 Ft. Includes E-8 & F-1 Cleaned for Oxygen Breathing	I.D. 3/8" O.D. 5/8" Working Pressure 250 psi Burst Pressure 1000 psi Inner Tube Nitrile, Black Braid Single Fiber Cover Neoprene
E-5	270-0011-01	Hose Grommet (3)	Thermoplastic Elastomer (TPE)
E-6	18970-00	Demand Hose, Oxy Clean	Brass, Nickel Plated
E-7	59852-00	Hose Plug, Exhaust Hose	Brass (O2 cleaned)
	320-0043-01	Hose Plug, Exhaust Hose	Brass (Not O2 cleaned)
E-9	320-0012-01	Spring, Spiral (2)	Stainless Steel
E-10	8900-011	1/2-20 Female Fitting (2)	Brass, Nickel Plated
E-12	320-0024-01	Ferrule (not shown)	Stainless Steel
F-1	59853-00	Quick Disconnect, Exhaust 3/8 NPT	Brass
F-2	18969-00	Quick Disconnect, Demand 1/8 NPT	Brass
F-3	B-6QDP	Plug for Exhaust Q.D. (Optional)	Brass

#### ITEMS NOT SHOWN ON PARTS DRAWING

460-0001-01	Head Net (Harness) Assembly
803152-(XX)M	Face seal Assembly with 150 ohm Microphone - (XX) equals size
1408	Microphone element 150 ohm dynamic
803200-(XX)	Retrofit Kit – upgrades Duo-Seal Inhalator to Pressur Vak II

Hoses and related fittings including Quick Disconnects Oxygen Cleaned to MIL STD. 1330D  
All other components cleaned to MIL-O-27210

**7.1 Avox Retrofit Kit (Part Number 803200-XX)**

The Avox Retrofit Kit is used to update the older version Avox overboard discharge 801238 Series Inhalator to the newer Pressur Vak II Inhalator with overboard discharge. The kit allows the reuse of all components of the 801238 series mask with the exception of the face seal.

The Retrofit Kit includes the following:

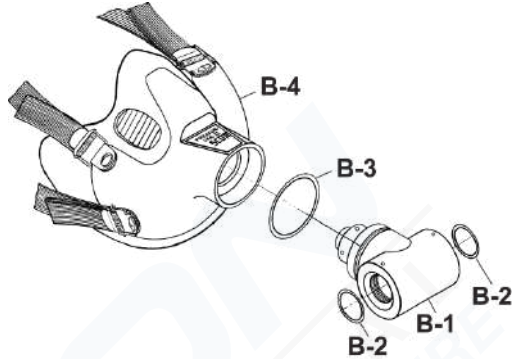

Item	Part Number	Description	Qty.
B-1	803100-01	Manifold Assembly	1
B-2	18062-00	O-ring, Manifold to Regulators	2
B-3	21506-01	O-ring, Manifold to Face seal	1
B-4	803152-XX	Face seal & Harness Assembly	1

The part number for the Retrofit Kit is dependent upon your choice of Face Seal with Harness size. Extra Small – 803200-05, Medium Small – 803200-01, Medium – 803200-02, Large – 803200-03, Extra Large – 803200-04.

**7.2 Retrofit Kit – Disassembly of 801238 Face Piece Assembly**

- Complete the following steps to retrofit the Avox 801238 Series Diver Inhalator to the Avox 803139 Series Pressur Vak II Inhalator. Disassemble only to the extent shown. Disassembly beyond the extent shown may result in permanent damage to the system.
- Open clamp (12) to allow removal of exhaust hose.
- Unthread-thread supply hose at the Demand Regulator. (26).
- Remove the demand regulator (26) from face seal assembly (43), by removing nut (17) and washer (18).
- Remove the exhaust regulator (29) from face seal assembly (43), by removing nut (27) and washer (28).
- Reassemble components using assembly and installation instructions for Pressur Vak II Inhalator.

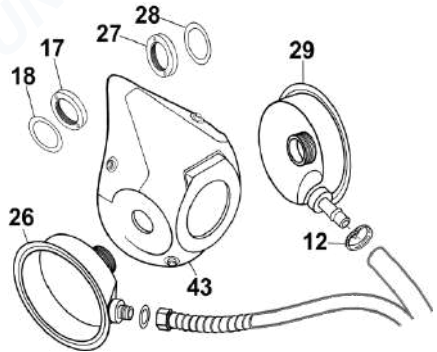

### 8.1 General Information

The Avox 801238 Series Overboard Discharge Inhalator incorporates all of the components of the Avox Pressur Vak II with the exception of the face seal and manifold assembly.

### 8.2 801238 Series OBD Parts Drawing

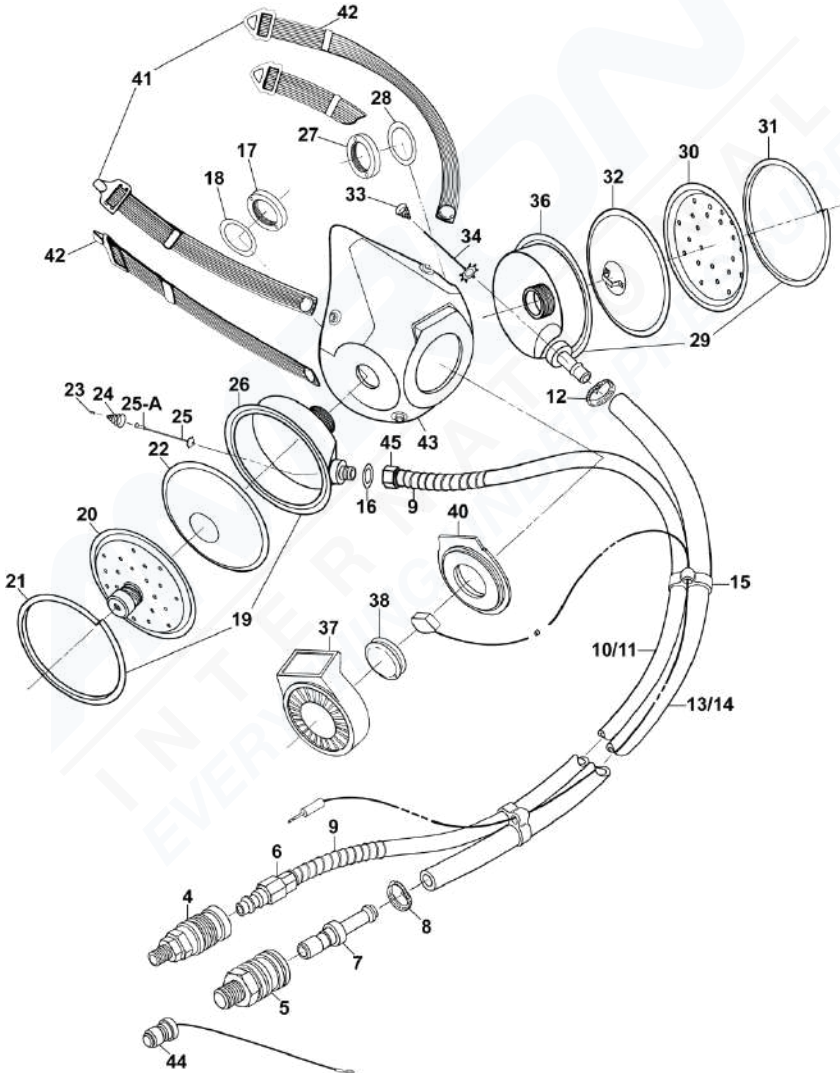

# 801238 SERIES OBD INHALATOR

# Section 8

## 8.1 801238-(XX)-(XX) 801238 Series Inhalator Parts Listing

Item	Part No.	Description
	803166-10	Dual Hose Assy. Complete
4	18969-00	Socket, Q.D.
5	59853-00	Socket, Q.D.
6	320-0013-01	Hose Plug
7	59852-00	Hose Stem – Oxygen Cleaned
	320-0043-01	Hose Stem (Optional) – Not Oxygen Cleaned
8	MLT2S-CP	Hose Clamp – Permanent (tool required)
9	320-0012-01	Spring, Spiral (2)
10	26037-10	Demand Hose, 10 ft. – Oxygen Cleaned
11	26037-25	Demand Hose, 25 ft. (Optional) – Oxygen Cleaned
12	20433-00	Replacement Hose Clamp,
13	59719-10	Exhaust Hose, 10 ft.
14	59719-25	Exhaust Hose, 25 ft. (optional)
15	270-0011-01	Hose Grommet
16	2827-49	Gasket, Demand Hose
17	10002551	Teflon Nut
18	10002550	Washer
19	800954-01	Demand Regulator Assy
20	801276-00	Cover
21	26010-01	Clamp
22	26004-01	Diaphragm
26	800956-01	Case Assy., (includes 23, 24, 25 & 25A)

Item	Part No.	Description
27	10002551	Teflon Nut
28	10002550	Washer
29	801274-00	Exhaust Regulator Assy
30	10003027	Cover
31	26010-01	Clamp
32	801272-00	Diaphragm & Stem Guide
33	13796-00	Spring
34	800963-00	Exhalation Valve Assy
36	801275-00	Regulator Case
37	801267-00	Guard and Plate Assy
38	10003063	Housing, Microphone
40	10003054	Holder
41	801266-00	Mask Assy. with Straps
42	604028-00	Strap Assy (2 left – 2 right)
43	801266-01	Mask without Straps
44	B-6QDP	Exhaust Plug for item 5 (optional)
45	8900-011	1/2-20 Female Fitting (2)

Repair Kits	
RK-800954-01	Demand Regulator Kit
RK-801238	Mask Kit

Hoses and related fittings including Quick Disconnects are Oxygen Cleaned to MIL STD. 1330D  
 All other components cleaned to MIL-O-27210

## Section 9

## 803600 SINGLE HOSE INHALATOR

### 9.1 General Information

The Avox 803600 Series Single Hose Inhalator is designed for dry atmosphere decompression and other applications where it is desirable to breathe mixtures other than ambient air. The 803600 Inhalator vents the exhaled gas directly to the chamber atmosphere.



Item	Part No.	Description
5	18969-00	Quick Disconnect
6	18970-00	Hose Plug
7	26037-08	Hose Assy. 8 ft.
8	800227-00	Demand Regulator Assy.
9	26018-01	Cover, Regulator
10	26010-01	Clamp, Regulator
11	26004-01	Diaphragm
12	2827-08	Gasket, Regulator to Face Seal
13	800228-00	Case Assy.
14	27495-00	Microphone Assy.
15	6232-00	Microphone only
16	708-8013	Cable, 2 cond. w/shield
17	27495-04	Housing, Microphone
18	803677-02	Face Seal with Straps
19	600118-00	Strap Assy.
22	64001-00	Buckle Bar & Clip
23	64152-02	Exhaust Valve Assy.
24	2827-49	Gasket, Hose
25	10005711	Plug
<b>Repair Kits</b>		
RK-803600		Repair Kit, Inhalator
RK-800227-00		Repair Kit, Regulator

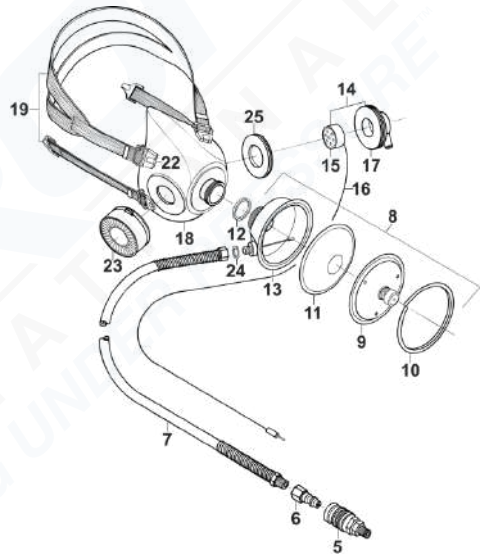

Hoses and related fittings including Quick Disconnects are Oxygen Cleaned to MIL STD. 1330D  
 All other components cleaned to MIL-O-27210

<b>Problem</b>	<b>Probable Cause</b>	<b>Remedy</b>
Leakage at chamber supply or chamber vacuum connection.	<ul style="list-style-type: none"> <li>• Loose connection</li> <li>• Cross threading</li> </ul>	<ul style="list-style-type: none"> <li>• Tighten fittings</li> <li>• Replace fittings</li> </ul>
Leakage at connections to regulator assembly	<ul style="list-style-type: none"> <li>• Loose fitting at demand regulator</li> <li>• Loose or damaged hose clamp at exhaust regulator</li> </ul>	<ul style="list-style-type: none"> <li>• Tighten fittings</li> <li>• Tighten or replace clamp</li> </ul>
Leakage at mating or regulator and mask assemblies	<ul style="list-style-type: none"> <li>• Loose nut or cross threading of nut or regulator case</li> <li>• Damaged O-ring</li> <li>• Stem Guide not positioned properly in diaphragm stem guide assembly</li> </ul>	<ul style="list-style-type: none"> <li>• Tighten nut. Replace nut or regulator case</li> <li>• Replace O-ring</li> <li>• Insert properly in stem guide</li> </ul>
No oxygen flow to mask assembly	<ul style="list-style-type: none"> <li>• Open connection at chamber or demand regulator connection</li> <li>• Foreign material lodged in hose stem</li> <li>• Damaged or crimped supply hose</li> </ul>	<ul style="list-style-type: none"> <li>• Reconnect fittings</li> <li>• Replace hose assembly</li> <li>• Straighten and inspect hose for damage. Replace if necessary</li> </ul>
Collapsed exhaust hose	<ul style="list-style-type: none"> <li>• Differential pressure to high</li> </ul>	<ul style="list-style-type: none"> <li>• Install secondary (BIBS) exhaust regulator. See Para. 1.7</li> </ul>
Free flow or continuous flow to mask	<ul style="list-style-type: none"> <li>• Foreign material lodged in demand valve stem seat</li> <li>• Damaged demand valve seat</li> </ul>	<ul style="list-style-type: none"> <li>• Inspect and remove material (determine source of contamination and correct)</li> <li>• Replace valve seat</li> </ul>
High breathing resistance (inhalation)	<ul style="list-style-type: none"> <li>• Inlet pressure to high</li> </ul>	<ul style="list-style-type: none"> <li>• Correct pressure as specified in Para 1.6 and 1.9</li> </ul>
High breathing resistance (exhalation)	<ul style="list-style-type: none"> <li>• Vacuum pressure too high or too low</li> </ul>	<ul style="list-style-type: none"> <li>• Correct pressure as specified in Para 1.7</li> </ul>

11.1 Inhalation Performance Chart

Typical Inhalation Performance  
Scott Inhalator with Overboard Discharge

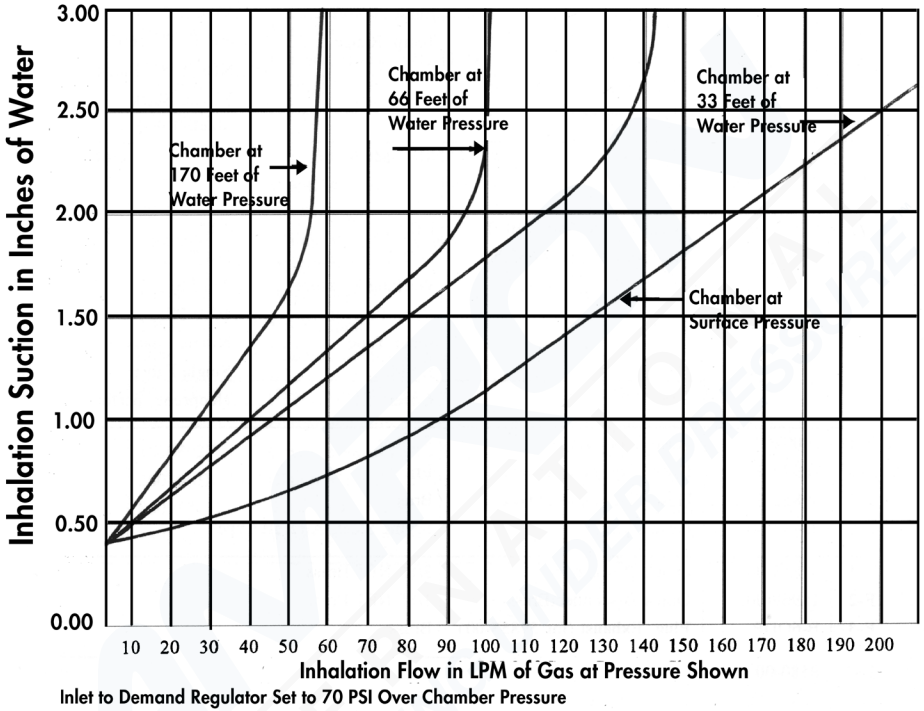

11.2 Exhalation Performance Chart

Typical Exhalation Performance using Air  
Scott Oxygen Inhalator with Overboard Discharge

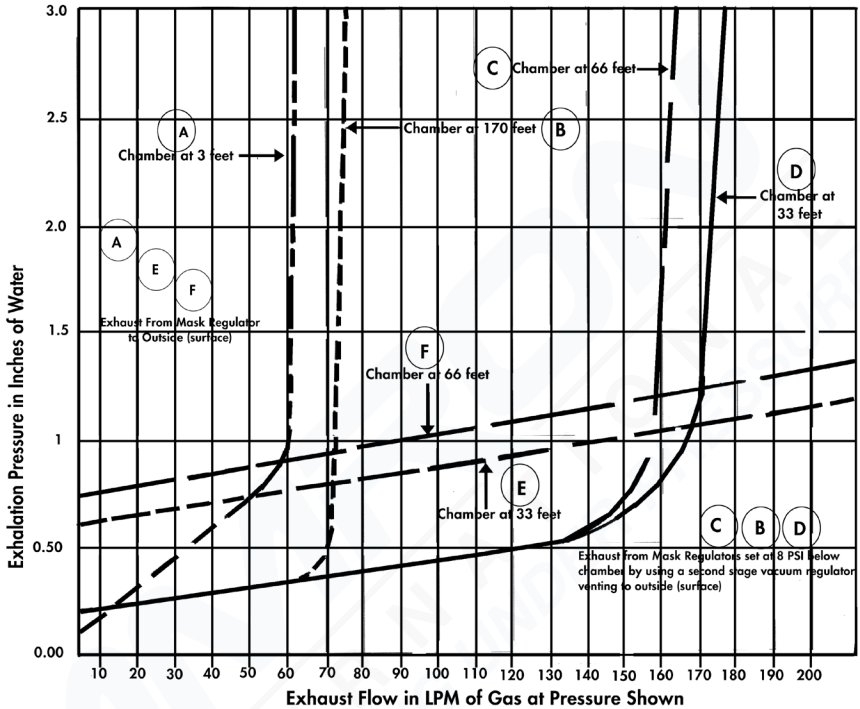

**Section 12**

**REPAIR LOG**

**Model Number:** \_\_\_\_\_

**Serial Number:** \_\_\_\_\_

Date	Service Code	Maintenance Performed and/or Parts Replaced	Condition of Unit	Repaired By

*For technical assistance, product information  
and parts replacement contact:*

**Amron International, Inc.  
1380 Aspen Way  
Vista, California 92081 USA**

**Phone: 760-208-6500  
Fax: 760-599-3857**

**E-mail: [sales@amronintl.com](mailto:sales@amronintl.com)  
Order on-line [www.amronintl.com](http://www.amronintl.com)**

Avox, the Avox Logo and Pressur Vak II  
are trademarks of  
Avox Systems, Inc. DBA Zodiac Oxygen Systems US