

# MODEL UWL-400 LOW VOLTAGE LED LIGHT

DEC.,08

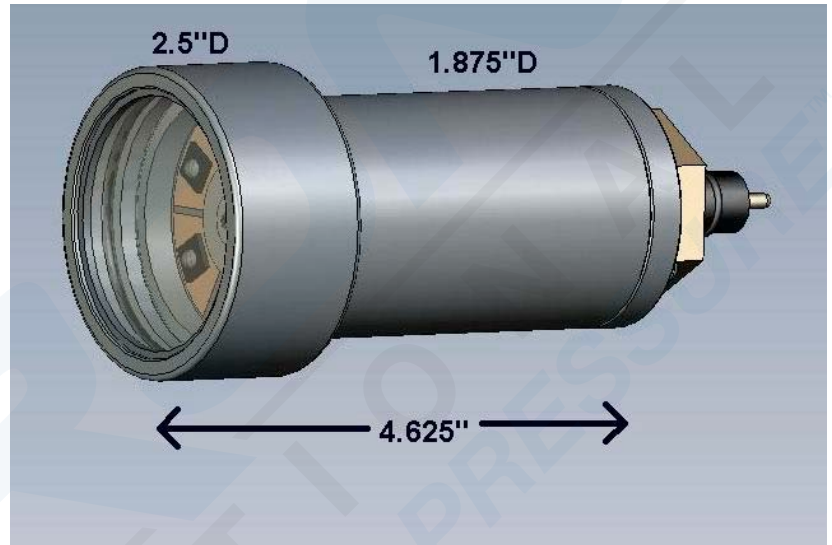

## APPLICATIONS INCLUDE: UNDERWATER CAMERA OR WORK LIGHTS

### MECHANICAL:

- Diameter..... 2.5 in (65mm)
- Length..... 4.60 in (115mm)  
(excluding connector)
- Weight..... (Dry) 18 oz. (.5 kg)  
(Wet) 8 oz. (.23kg)
- Depth Rating..... 2000 ft. (600m)
- Housing..... Anodized Aluminum
- Port ..... Acrylic
- Connector..... XSG-3-BCL  
(Mating Connector.... RMG-3-FS)

### ELECTRICAL:

- Voltage..... 24 VDC
- Wattage..... 35 WATTS  
(Equiv. TO 250 WATT Halogen)
- Beam Angle..... 110 degrees
- Output ..... 1030 lux@1mt  
(Typically 1740 lumens)

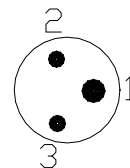

Pin 1 = 24 vdc+  
Pin 2 = 24 vdc -  
Pin 3 = 0-24 vdc control