

Kingston Safety & Relief Valves

Kingston Model 118CSS

ASME Code High Flow Safety Valve
Brass, Stainless Steel Ball



Features:

- High Flow Capacity
- Precision Machined Hard Seat
- Brass Construction
- Stainless Steel Ball & Spring
- Pull Ring for Manual Testing
- ASME Certified - Stamped UV + NB
- Registered in All Canadian Provinces & Territories
- Maximum Temperature 400°F
- Set Pressure Range 25-300 PSIG
- Every Safety Valve Factory Set and Tested

Model	Available Sizes	Orifice	Figure/Part No	Dimensions (inches)		Set Pressure Range PSIG	Approximate Ship Weight	Max Temp
				Height (A)	Hex (B)			
118CSS	1/4" NPT	.295	118CSS-2-000	3 3/16	5/8	25-300	3 oz	400°F
	3/8" NPT	.343	118CSS-3-000	3 9/16	3/4		5 oz.	
	1/2" NPT	.343	118CSS-4-000	3 13/16	7/8		9 oz.	
	3/4" NPT	.578	118CSS-5-000	5 7/16	1 1/2		1 lb. 2 oz	
	1" NPT	.578	118CSS-6-000	5 3/4	1 5/16		1 lb. 5 oz	

Materials

No.	Part Name	Materials
1	Body	Brass
3	Stem Assembly	Brass Stem, Stainless Steel Ball
4	Spring	Stainless Steel
5	Adjusting Screw	Brass
6	Lock Nut	Brass
7	Cap	Brass
8	Pull Ring	Stainless Steel
9	Seal	Vinyl

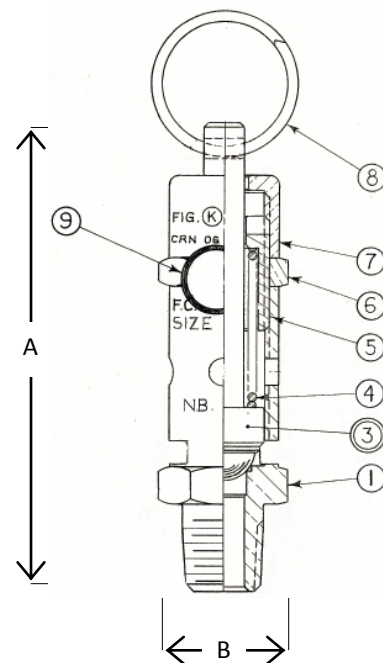

www.KingstonValves.com

Storm Manufacturing Group
23201 Normandie Ave., Torrance CA 90501-5050
Toll Free: 866-628-8287 Fax: 800-997-0500 Direct: 310-326-8287

Copyright 2010 © Storm Manufacturing Group. All rights reserved. Product designs and specifications subject to change without notice. r.10b

Kingston Model 118CSS Safety Relief Valve

Flow Capacity Information

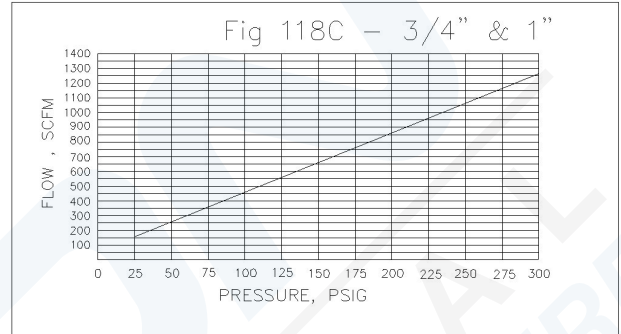
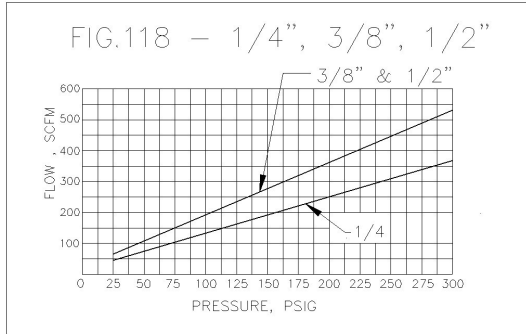

Ordering Information

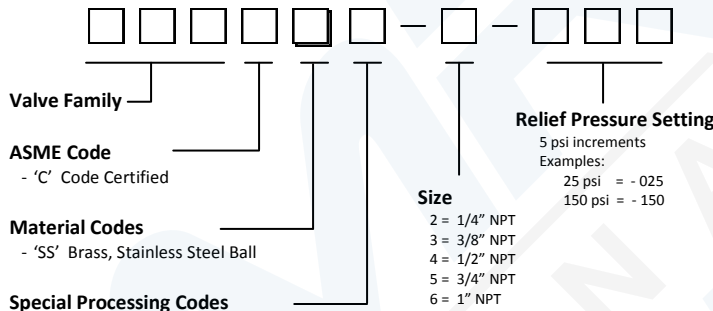

KINGSTON® Model 118

SET PRESSURE	STAMPED CFM				SET PRESSURE	STAMPED CFM			
	1/4"	3/8", 1/2"	3/4"	1"		1/4"	3/8", 1/2"	3/4"	1"
25	45	65	155	155	165	210	302	720	720
30	51	73	175	175	170	216	311	740	740
35	57	82	195	195	175	222	319	760	760
40	63	90	215	215	180	228	328	781	781
45	69	99	236	236	185	233	336	801	801
50	75	107	256	256	190	239	344	821	821
55	80	116	276	276	195	245	353	841	841
60	86	124	296	296	200	251	361	861	861
65	92	133	316	316	205	257	370	882	882
70	98	141	336	336	210	263	378	902	902
75	104	150	357	357	215	269	387	922	922
80	110	158	377	377	220	275	395	942	942
85	116	167	397	397	225	281	404	962	962
90	122	175	417	417	230	286	412	982	982
95	128	184	437	437	235	292	421	1003	1003
100	133	192	458	458	240	298	429	1023	1023
105	139	201	478	478	245	304	438	1043	1043
110	145	209	498	498	250	310	446	1063	1063
115	151	217	518	518	255	316	455	1083	1083
120	157	226	538	538	260	322	463	1104	1104
125	163	234	559	559	265	328	472	1124	1124
130	169	243	579	579	270	334	480	1144	1144
135	175	251	599	599	275	339	488	1164	1164
140	181	260	619	619	280	345	497	1184	1184
145	186	268	639	639	285	351	505	1202	1202
150	192	277	659	659	290	357	514	1225	1225
155	198	285	680	680	295	363	522	1245	1245
160	204	294	700	700	300	369	531	1265	1265

Product Notes

All Kingston Safety Valves are manufactured under a quality control system accepted by the National Board of Boiler and Pressure Vessel Inspectors.

Code valves are capacity certified by the National Board, manufactured in accordance with ASME Code, set and sealed at the factory.

Set pressure can deviate from the marked by ± 2 psig at or below 70 psig set pressures and $\pm 3\%$ psig above 70 psig.

Factory standard seat tightness for hard seat valves: no audible leakage at 20% below nameplate set. It is normal for spring-operated safety valves to exhibit leakage or simmer/warn, as the system operating pressure approaches the set pressure. For hard seat valves this typically occurs at pressures at or above 80% of nameplate set pressure.

At very low set pressures (20 psi and below), the ratio of the downward spring force as compared to the upward pressure force is very small. In these cases it may be impossible to achieve seat tightness.

Soft seat valves will typically provide a higher degree of seat tightness than metal, hard seats. Factory standard seat tightness does not ensure bubble-tight seal regardless of material.

Final application design and integration of Kingston Products are the sole responsibility of the end user.

Storm Manufacturing reserves all rights. Product specifications and designs are subject to change without notice.



Storm Manufacturing Group
23201 Normandie Ave., Torrance CA 90501-5050
Toll Free: 866-628-8287 Fax: 800-997-0500 Direct: 310-326-8287

Copyright 2010 © Storm Manufacturing Group. All rights reserved. Product designs and specifications subject to change without notice. r.10b