

---

**STANLEY**

®

GT18

HYDRAULIC  
POWER UNIT



**SAFETY, OPERATION AND MAINTENANCE  
USER'S MANUAL**



---

---

---

# TABLE OF CONTENTS

---

Safety Symbols.....	4
Safety Precautions .....	5
Tool Stickers & Tags .....	6
Hydraulic Hose Requirements.....	7
HTMA Requirements .....	8
Operation.....	9
Routine Maintenance.....	13
Programmable Controller .....	14
Fault Codes .....	15
Testing & Troubleshooting .....	16
Specifications .....	18
Parts Lists & Illustrations .....	19
Briggs Engine Assembly (Fig. 1) .....	19
Briggs Engine Parts List.....	20
Honda Engine Assembly (Fig. 1A) .....	21
Honda Engine Parts List .....	22
Frame Parts (Fig. 2).....	23
Hoses, Fittings & Clamps (Fig. 3) .....	24
Wiring Diagram - Additional Wiring for Honda (Fig. 4) .....	25
Wiring Diagram - POWERLINK™ (Fig. 4A) .....	26
Wiring Diagram - Main Power Unit.....	27
Warranty .....	28

**SERVICING THE STANLEY POWER UNIT:** This manual contains safety, operation, and routine maintenance instructions. Stanley Hydraulic Tools recommends that servicing of hydraulic tools, other than routine maintenance, must be performed by an authorized and certified dealer. Please read the following warning.

**⚠ WARNING**

**SERIOUS INJURY OR DEATH COULD RESULT FROM THE IMPROPER REPAIR OR SERVICE OF THIS TOOL.**

**REPAIRS AND / OR SERVICE TO THIS TOOL MUST ONLY BE DONE BY AN AUTHORIZED AND CERTIFIED DEALER.**

For the nearest authorized and certified dealer, call Stanley Hydraulic Tools at the number listed on the back of this manual and ask for a Customer Service Representative.

---

# SAFETY SYMBOLS

---

Safety symbols and signal words, as shown below, are used to emphasize all operator, maintenance and repair actions which, if not strictly followed, could result in a life-threatening situation, bodily injury or damage to equipment.



This is the safety alert symbol. It is used to alert you to potential personal injury hazards. Obey all safety messages that follow this symbol to avoid possible injury or death.



This safety alert and signal word indicate an imminently hazardous situation which, if not avoided, will result in death or serious injury.



This safety alert and signal word indicate a potentially hazardous situation which, if not avoided, could result in death or serious injury.



This safety alert and signal word indicate a potentially hazardous situation which, if not avoided, may result in minor or moderate injury.



This signal word indicates a potentially hazardous situation which, if not avoided, may result in property damage.



This signal word indicates a situation which, if not avoided, will result in damage to the equipment.



This signal word indicates a situation which, if not avoided, may result in damage to the equipment.

Always observe safety symbols. They are included for your safety and for the protection of the tool.

## LOCAL SAFETY REGULATIONS

Enter any local safety regulations here. Keep these instructions in an area accessible to the operator and maintenance personnel.

---

---

---

---

---

---

# SAFETY PRECAUTIONS

---

Tool operators and maintenance personnel must always comply with the safety precautions given in this manual and on the stickers and tags attached to the equipment.

These safety precautions are given for your safety. Review them carefully before operating the tool and before performing general maintenance or repairs.

Supervising personnel should develop additional precautions relating to the specific work area and local safety regulations. If so, place the added precautions in the space provided on page 4.

In addition to this manual, read and understand safety and operating instructions in the Engine Operation Manual furnished with the power unit.

The GT18 Hydraulic Power Unit will provide safe and dependable service if operated in accordance with the instructions given in this manual. Read and understand this manual and any stickers and tags attached to the Power Unit. Failure to do so could result in personal injury or equipment damage.



- Operator must start in a work area without bystanders. The operator must be familiar with all prohibited work areas such as excessive slopes and dangerous terrain conditions.
- Establish a training program for all operators to ensure safe operation.
- Do not operate the power unit unless thoroughly trained or under the supervision of an instructor.
- Always wear safety equipment such as goggles, ear, head protection, and safety shoes at all times when operating the power unit and a hydraulic tool.
- Do not inspect or clean the power unit while it is running. Accidental engagement of the unit can cause serious injury.
- Always use hoses and fittings rated at 2500 psi/172 bar with a 4 to 1 safety factor. Be sure all hose connections are tight.
- Be sure all hoses are connected for correct flow direction to and from the tool being used.
- Do not inspect hoses and fittings for leaks by using bare hands. "Pin-hole" leaks can penetrate the skin.
- NEVER OPERATE THE POWER UNIT IN A CLOSED SPACE. Inhalation of engine exhaust can be fatal.
- Do not operate a damaged, improperly adjusted power unit.
- Never wear loose clothing that can get entangled in the working parts of the power unit.
- Keep all parts of your body away from the working parts of the power unit.
- Keep clear of hot engine exhaust.
- Do not add fuel to the power unit while the power unit is running or is still hot.
- Do not operate the power unit if gasoline odor is present.
- Do not use flammable solvents around the power unit engine.
- Do not operate the power unit within 3.3 ft/1 m of buildings, obstructions or flammable objects.
- Do not reverse tool rotation direction by changing fluid flow direction.
- Allow power unit engine to cool before storing in an enclosed space.
- Always keep critical tool markings, such as labels and warning stickers legible.
- To avoid personal injury or equipment damage, all tool repair, maintenance and service must only be performed by authorized and properly trained personnel.

# TOOL STICKERS & TAGS



62302

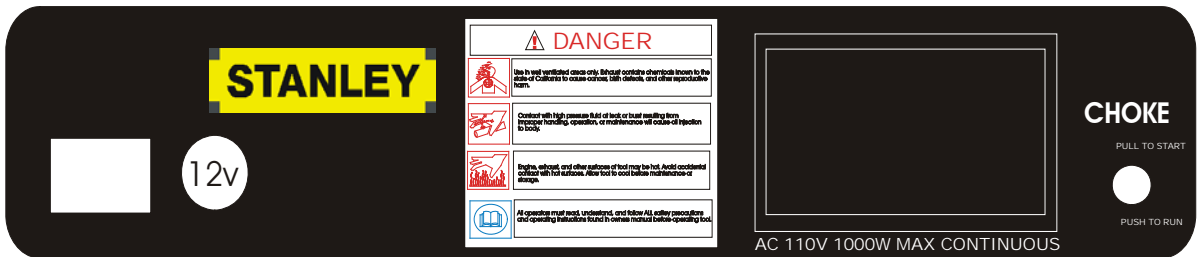

62318 POWERLINK™ Only



62300



62305 POWERLINK™ Only

# HYDRAULIC HOSE REQUIREMENTS

## HOSE TYPES

Hydraulic hose types authorized for use with Stanley Hydraulic Tools are as follows:

- 1 Certified non-conductive
- 2 Wire-braided (conductive)
- 3 Fabric-braided (not certified or labeled non-conductive)

Hose 1 listed above is the only hose authorized for use near electrical conductors.

Hoses 2 and 3 listed above are **conductive** and **must never** be used near electrical conductors.

## HOSE SAFETY TAGS

To help ensure your safety, the following DANGER tags are attached to all hose purchased from Stanley Hydraulic Tools. **DO NOT REMOVE THESE TAGS.**

If the information on a tag is illegible because of wear or damage, replace the tag immediately. A new tag may be obtained from your Stanley Distributor.

### THE TAG SHOWN BELOW IS ATTACHED TO “CERTIFIED NON-CONDUCTIVE” HOSE

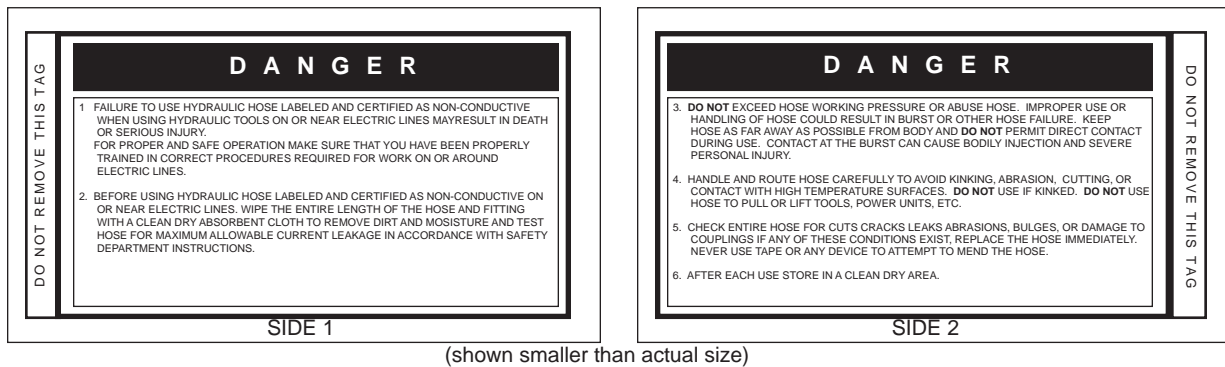

### THE TAG SHOWN BELOW IS ATTACHED TO “CONDUCTIVE” HOSE.

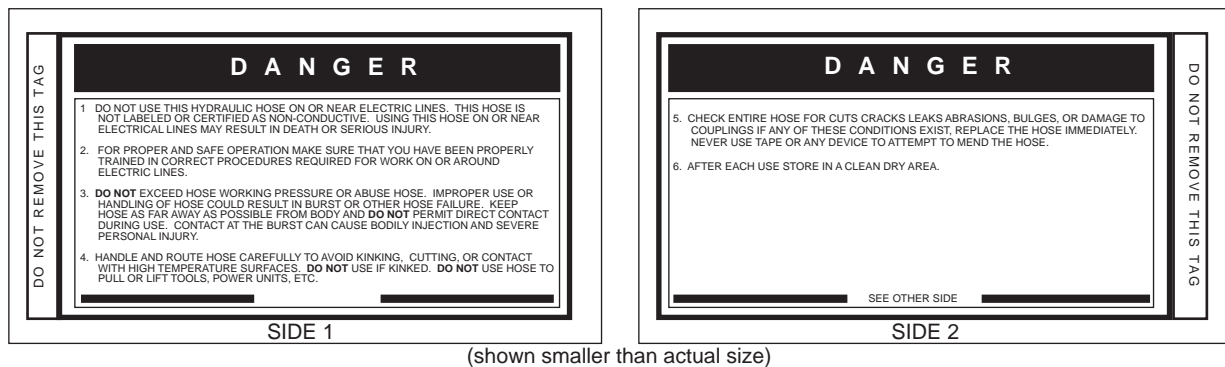

## HOSE PRESSURE RATING

The rated working pressure of the hydraulic hose **must be equal to or higher than** the relief valve setting on the hydraulic system.

# HTMA REQUIREMENTS

## TOOL CATEGORY



## HYDRAULIC SYSTEM REQUIREMENTS

TYPE I

TYPE II

TYPE III

TYPE RR

FLOW RATE	4-6 gpm (15-23 lpm)	7-9 gpm (26-34 lpm)	11-13 gpm (42-49 lpm)	9-10.5 gpm (34-40 lpm)
TOOL OPERATING PRESSURE (at the power supply outlet)	2000 psi (138 bar)	2000 psi (138 bar)	2000 psi (138 bar)	2000 psi (138 bar)
SYSTEM RELIEF VALVE SETTING (at the power supply outlet)	2100-2250 psi (145-155 bar)	2100-2250 psi (145-155 bar)	2100-2250 psi (145-155 bar)	2200-2300 psi (152-159 bar)
MAXIMUM BACK PRESSURE (at tool end of the return hose)	250 psi (17 bar)	250 psi (17 bar)	250 psi (17 bar)	250 psi (17 bar)
Measured at a max. fluid viscosity of: (at min. operating temperature)	400 ssu* (82 centistokes)	400 ssu* (82 centistokes)	400 ssu* (82 centistokes)	400 ssu* (82 centistokes)
TEMPERATURE Sufficient heat rejection capacity to limit max. fluid temperature to: (at max. expected ambient temperature)	140° F (60° C)	140° F (60° C)	140° F (60° C)	140° F (60° C)
Min. cooling capacity at a temperature difference of between ambient and fluid temps	3 hp (2.24 kW) 40° F (22° C)	5 hp (3.73 kW) 40° F (22° C)	7 hp (4.47 kW) 40° F (22° C)	6 hp (5.22 kW) 40° F (22° C)
NOTE: Do not operate the tool at oil temperatures above 140° F (60° C). Operation at higher temperatures can cause operator discomfort at the tool.				
FILTER Min. full-flow filtration Sized for flow of at least: (For cold temp. startup and max. dirt-holding capacity)	25 microns 30 gpm (114 lpm)	25 microns 30 gpm (114 lpm)	25 microns 30 gpm (114 lpm)	25 microns 30 gpm (114 lpm)
HYDRAULIC FLUID Petroleum based (premium grade, anti-wear, non-conductive) VISCOSITY (at min. and max. operating temps)	100-400 ssu*	100-400 ssu* (20-82 centistokes)	100-400 ssu*	100-400 ssu*
NOTE: When choosing hydraulic fluid, the expected oil temperature extremes that will be experienced in service determine the most suitable temperature viscosity characteristics. Hydraulic fluids with a viscosity index over 140 will meet the requirements over a wide range of operating temperatures.				

\*SSU = Saybolt Seconds Universal

### NOTE:

These are general hydraulic system requirements. See tool Specification page for tool specific requirements.



# OPERATION

## PREPARATION FOR USE

Do not operate the power unit until you have read the *engine* operating and maintenance instructions manual furnished with the unit.

### 1. ENGINE CRANKCASE OIL LEVEL

Always check the oil level before starting the engine. Make sure the oil level is at the FULL MARK on the dipstick. Do not overfill. Use detergent oil classified "For Service SE, SF, SG" as specified in the engine operating and maintenance manual. See engine manual for oil viscosity grade.

### 2. SPARK PLUG

On power units equipped with Briggs & Stratton Engines, ONLY Champion RC12YC or equivalent can be used.

For power units equipped with Honda Engines, ONLY Denso J16CR-U or equivalent can be used.

Incorrect type spark plugs can produce radio frequency interference that will corrupt and damage the controller. Failure to use the correct spark plug could result in a warranty that will not be considered.

### 3. ENGINE FUEL LEVEL

Check the fuel level. If low, fill with un-leaded gasoline with a minimum of 85 octane.

### 4. HYDRAULIC FLUID

Check the dip stick in the hydraulic fluid reservoir for the proper fluid level. Use fluids meeting the following specifications.

Viscosity (Fluid Thickness)

#### U.S.

50°F 450 SSU Maximum  
100°F 130-200 SSU  
140°F 85 SSU Minimum

#### METRIC

10°C 95 C.S.  
38°C 27-42 C.S.  
60°C 16.5 C.S. Min

**Pour Point** -10°F/-23°C Minimum (for cold startup)

**Viscosity Index** (ASTM D-2220) 140 Minimum

**Demulsibility** (ASTM D-1401) 30 Minutes Maximum

**Flash Point** (ASTM D-92) 340°F/171°C Minimum

**Rust Inhibition** (ASTM D-665 A & B) Pass

**Oxidation** (ASTM D-943) 1000 Hours Minimum

**Pump Wear Test** (ASTM D-2882) 60 mg Maximum

The following fluids work well over a wide temperature range, allow moisture to settle out and resist biological growth that may occur in cool operating hydraulic circuits. These fluids are recommended by Stanley. Other fluids that meet or exceed the specifications of these fluids may also be used.

Chevron AW-MV-32

Exxon "Univis" J-26

Mobil D.T.E. 13

Gulf "Harmony" AW-HVI-150-32

Shell "Tellus" T-32

Texaco "Rando" HD-AZ

Union "Unax" AW-WR-32

Terresolve EnviroLogic 132

### 5. HYDRAULIC CONNECTIONS

The recommended hose length is 25 ft/8 m with a 1/2 inch/12.7 mm inside diameter. The hoses must have a working pressure rating of at least 2500 psi/175 bar. Each hose end must have male thread ends compatible with H.T.M.A. (HYDRAULIC TOOL MANUFACTURERS ASSOCIATION) quick disconnect fittings (NPT type threads). (See Figure 2.)



Figure 1. Panel Control Valve

Facing the panel control valve, the bottom male quick disconnect fitting is the PRESSURE FLUID OUT fitting. The top female quick disconnect fitting is the RETURN FLUID IN fitting.

### QUICK DISCONNECT COUPLERS

H.T.M.A. approved quick disconnect couplings are installed to hydraulic hoses so that the direction of oil flow is always from the male to the female quick disconnect as shown in figure 2. Quick disconnect couplings and hose fittings are

# OPERATION

selected so that additional fittings such as reducer or adapter fittings are not required.

If adapter fittings are used, they must be approved steel hydraulic fittings meeting a minimum operating pressure rating of 2500 psi/172 bar. Do not use galvanized pipe fittings or black pipe fittings.

Use thread tape or pipe joint compound when installing quick disconnect couplings to hose or tool fittings. Follow the instructions furnished with the selected thread sealant. **DO NOT OVERTIGHTEN THE FITTINGS.**

## 6. BATTERY

The supplied 12 Volt DC battery is a non-spillable, maintenance-free battery and is fully charged.

Make sure the battery cables are tight and charging circuit functions are operating properly.

### NOTICE

Do not charge the battery with a standard automotive battery charger. This type of charger produces a charging amperage higher than 2 amps. Charging the battery at higher than 2 amps will damage the battery.

### NOTICE

If the engine runs out of gas or dies during operation and the ignition switch is left in the ON or RUN position, this could drain the battery. Make sure the ignition switch is returned to the OFF position.

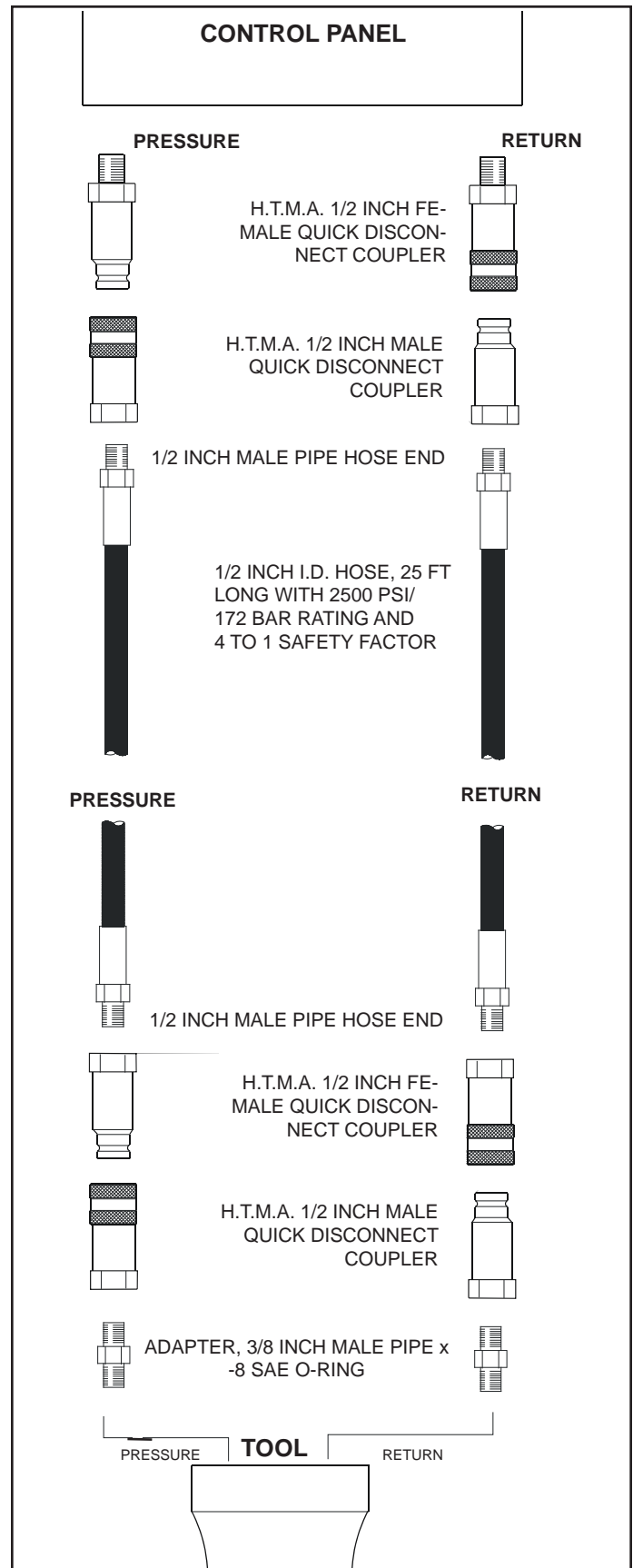

Figure 1. Hydraulic Connections

---

# OPERATION

---

---

## CONTROLS

---

This unit is equipped with an advanced proportional engine control system. It provides a means of controlling engine speed by adjusting the fuel control lever with an actuator. The Power Unit provides one circuit, with an oil flow of 5 gpm/19 lpm up to 2000 psi/140 bar or 8 gpm/30 lpm up to 2000 psi/140 bar with a factory-programmed electronic governed engine throttle.

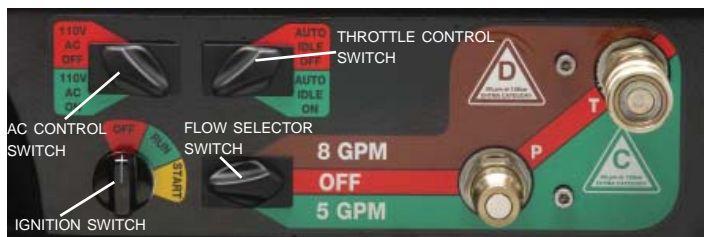

Figure 3. Panel Control Valve

One hydraulic tool can be connected to the tool circuit. The circuit is activated by turning the flow control switch to either the 5 gpm/19 lpm or 8 gpm/30 lpm setting.

### THROTTLE CONTROL

The throttle control permits the operator to select one of 2 operating modes after the engine has warmed up. When starting the engine, make sure the flow selector switch is in the OFF position. The throttle control switch can be set in either the AUTO-IDLE-ON or AUTO-IDLE-OFF positions.

### AUTO-ON

When the throttle control switch is in the "AUTO-ON" position, the oil flow is regulated automatically when the trigger on the tool activated. When the tool is not being used the engine will return to idle automatically, after a 10 second delay.

This setting will produce 5 gpm/19 lpm or 8 gpm/30 lpm depending on which position the operator has selected with the flow selector switch.

### AUTO-OFF

When the throttle control switch is in the "AUTO-OFF" position, the engine speed is held to maintain 5 gpm/19 lpm or 8 gpm/30 lpm depending on which position the operator has selected with the flow selector switch. When a tool is not being used the engine will not return to idle until either the flow selector switch is turned to the OFF position or the throttle control switch is turned to AUTO-ON.

### Note:

**It may be necessary to reset the Controller.**

At times it may be necessary to reset the controller. This could happen if a fault occurs in the controller. For example, excessive engine speed. If a fault does occur the power unit will return to an idle and the operator will have no control of the unit. To reset the controller, simply turn off the power unit and restart it.

---

## USING THE 110 VOLT AC OUTLET

---

The 110 volt AC outlet is only found on specific models with the Briggs & Stratton engine.

The POWELINK™ system output remains 110 volts throughout the entire engine speed range. Output wattage increases with engine speed.

To use the 110 volt AC feature, turn the AC control switch to the ON position. The 110 volt outlet can also be used while in the 8 gpm mode, but is disabled when the flow control switch is set to the 5 gpm mode.

See included POWERLINK™ On-Board Generator System Manual for details.

---

## USING THE 12 VOLT DC OUTLET

---

A 12 VDC outlet is on specific models. The DC outlet is ON at all times.

### IMPORTANT

The accessories (if left on) that are plugged into this outlet could drain the battery.

---

## STARTUP

---

Before starting the engine make sure the flow selector switch is in the OFF position.

### Note:

**The power unit will not start if the flow control switch is not in the "OFF" position.**

Pull choke knob out and move the Throttle Control Switch to the auto-idle-off or the auto-idle-on position, whichever mode of operation the operator prefers. Ensure the flow selector switch is in the OFF position.

On power units equipped with the POWERLINK™ feature,

---

# OPERATION

---

it is good practice to start the power unit with the AC Control Switch in the OFF position. The unit will however start with this switch in either the ON or OFF position.

**Note:**

**If the power unit is started in the ON position, the 110 volt AC outlet will not function unless the switch is turned off and back on again.**

Turn the Ignition Switch to the START position. After the engine starts, release the switch.

Gradually push in the choke knob as the engine begins to idle smoothly.

Allow the engine to warm up.

Connect hoses and the tool as described on pages 9 and 10.

## FOR 5 GPM OPERATION

For 5 gpm operation, select mode of operation with the Throttle Control switch, either auto-idle-on or the auto-idle-off position. Move the flow selector switch to the 5 gpm position.

When finished operating the tool, move the flow selector switch to the OFF position.

## FOR 8 GPM OPERATION

For 8 gpm operation, select mode of operation with the Throttle Control Switch, either auto-idle-on or the auto-idle-off position. Move the flow selector switch to the 8 gpm position.

When finished operating the tool, move the flow selector switch to the OFF position.

---

## COLD WEATHER STARTUP

---

1. Use the procedures described under "STARTUP" and then follow the procedure below.

2. Hydraulic fluids are thicker in cold weather. Therefore, it is recommended that the engine be run at low idle long enough to bring the fluid temperature up to a minimum of 50°F/10°C.

3. If the tools and tool hoses are cold, it is recommended to allow hydraulic fluid to circulate through the tool hoses until warm before using the tool.

---

## SHUTDOWN

---

1. Ensure the flow selector switch in the OFF position (center position).

2. Unless already at idle the power unit should return to idle. This may take a few seconds for the unit to react due to a built-in program delay.

3. Allow the engine to idle for approximately one minute and move the Ignition Switch to the OFF position.

---

# ROUTINE MAINTENANCE

---

## ENGINE MAINTENANCE

Follow the maintenance schedule and general maintenance instructions in the engine maintenance and operation manual furnished with the power unit.

## SPARK PLUGS

On power units equipped with Briggs & Stratton Engines, ONLY Champion RC12YC or equivalent can be used.

For power units equipped with Honda Engines, ONLY Denso J16CR-U or equivalent can be used.

Incorrect type spark plugs can produce radio frequency interference that will corrupt and damage the controller. Failure to use the correct spark plug could result in a warranty that will not be considered.

## HYDRAULIC SYSTEM MAINTENANCE

- Check hydraulic fluid level daily. Add fluid per specifications in this manual. (See "HYDRAULIC FLUID" under the section titled "OPERATING INSTRUCTIONS").
- Remove condensed moisture from the hydraulic fluid by pumping the hydraulic fluid into a 5 gal/20 l container through the pressure hose. Make sure the engine is at idle when performing this procedure. When the hydraulic reservoir is empty turn the engine off immediately.
- Allow the fluid to sit long enough for the water to settle to

the bottom of the container. Slowly pour the fluid back into the hydraulic tank, avoiding the water at the bottom of the container.

- Each day, check hydraulic lines and fittings for leaks, kinks, etc. Do not use your hand to perform this check.
- Change the hydraulic filter element every 200 hours of operation. Change more often if cold, moist or dusty conditions exist.
- Check oil cooler for debris. Remove debris with air pressure.

---

## STORAGE

---

- Clean the unit thoroughly before storage. Do not use water pressure.
- Always store the unit in a clean and dry facility.
- If the unit will be stored for a prolonged period (over 30 days), add a fuel additive to the fuel tank to prevent the fuel from gumming. Run engine for a short period to circulate

---

# PROGRAMMABLE CONTROLLER

---

The Stanley programmable controller is an electronic engine governor that provides a means of controlling and limiting engine speed by adjusting the fuel control lever with a proportional actuator.

The controller is software programmable and has no manual adjustments.

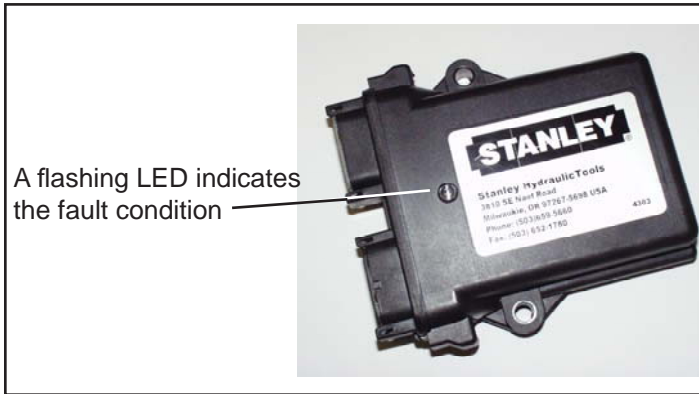

---

## CALIBRATION

---

ACT is a PC (personal computer) based software calibration and monitoring tool. ACT is designed specifically for use with engines equipped with the Stanley controller. Stanley Hydraulic Tools recommends that an authorized and certified dealer perform calibration of this unit.

Once the controller has been programmed, ACT may be disconnected. The Stanley controller will continue to operate normally with ACT either connected or disconnected.

---

## TROUBLESHOOTING GUIDELINES

---

Please follow the checklist below to troubleshoot your Stanley controller.

1. Check battery voltage for stability and correct value. The LED will turn on for one second when the controller 4500 is first powered up.
2. Check the actuator linkage for binding and backlash.

## CHECKING PERFORMANCE CONTROL™ (ELECTRONIC GOVERNOR-STATIC CHECK)

To determine whether a governor problem is being caused by the actuator or the control module, perform the following static check exactly in order shown.

A pair of jumper wires and a known good 12-volt battery is required.

1. Disconnect red and green wires from the control module to actuator.

2. Attach jumper wires from battery to RED and GREEN wires to actuator.

- a. Attach 12 volt + (positive) to RED wire.
- b. Attach 12 volt – (negative) to GREEN wire.

3. Actuator should move throttle lever to wide open position.

- a. If actuator does not move it is defective. (Replace).
- b. If actuator moves throttle to wide-open position, the module is defective. (Replace).

---

## FAULT CODES

---

The Stanley controller is capable of identifying certain fault conditions and alerting the user to them. A flashing LED indicates the fault conditions. The current fault code list is shown on the following page. Please note the following:

1. When power is first applied to the controller, the LED will flash just once for one second to indicate that the LED is working.
2. If there are multiple faults, the LED will flash them all in sequence. Count the flash codes to determine the fault conditions or connect the Calibration Tool to observe the fault conditions. (Use the “Display Faults” option under the Monitor Menu.)
3. If there are no faults, the LED will flash once at reset and from then on indicate the detection of engine speed. A continuous ON LED indicates that a valid engine speed is being sensed.
4. The controller will attempt to shut down for some faults and will not permit starting after reset with faults 1, 5 and 8.

# FAULT CODES

FLASH CODE	FAULT	ENGINE SHUTDOWN	CORRECTIVE ACTION
1	APECS unit not calibrated	yes	Have engine serviced by an Authorized Stanley Dealer.
2	Engine speed excessive	yes	Have engine serviced by an Authorized Stanley Dealer.
3	Engine speed unusually low	yes	Have engine serviced by an Authorized Stanley Dealer.
4	Engine shutdown due to engine protection input	yes	Have engine serviced by an Authorized Stanley Dealer.
5	Factory settings lost	yes	Have engine serviced by an Authorized Stanley Dealer.
6	External pot out-of-range	no	Have engine serviced by an Authorized Stanley Dealer.
7	Accelerator position / idle switch conflict	no	Have engine serviced by an Authorized Stanley Dealer.
8	Controller unit failed	yes	Have engine serviced by an Authorized Stanley Dealer.
9	Limiting excessive actuator current	no	Have engine serviced by an Authorized Stanley Dealer.
10	Engine speed input signal missing	no	(Active only in Auto crank mode). Check speed sensor wiring. Check starter motor.
11	Auto crank unable to start engine	no	Check fuel.
12	Auxiliary output is shorted	no	Check the lamp or relay hooked to the output. If fault is still present, have engine serviced by an authorized Stanley Dealer.
13	Auxiliary output #2 is shorted	no	Check the lamp or relay hooked to the output. If fault is still present, have engine serviced by an authorized Stanley dealer.
14	Actuator disconnected or open circuit	no	Check actuator wiring and actuator resistance. Resistance should be less than 10 ohms.

---

# TESTING & TROUBLESHOOTING

---

---

## GENERAL

---

Tests and adjustments should be performed periodically to ensure the power unit is operating at maximum efficiency. Stanley Circuit Tester (part number 04182) is recommended. This tester can be used to isolate problems in both the engine and hydraulic system prior to any power unit disassembly.

---

## TESTING THE HYDRAULIC CIRCUIT

---

The following tests can be performed to ensure that the hydraulic pump is supplying the correct flow and pressure and that the system relief valve is operating properly.

During these tests, make sure the engine is warm and operating smoothly. If test results are not as specified, refer to the troubleshooting table in this section for possible causes.

## TESTING THE 5 GPM HTMA TYPE 1 CIRCUIT

To test the circuit, proceed as follows:

1. Set the flow selector switch to the OFF (center) position.
2. Set the throttle control switch to AUTO-OFF position.
3. Connect the Stanley Circuit Tester across two hose ends (where the tool would normally be connected).
4. Fully open the tester restrictor valve (counterclockwise).
5. Start the engine and allow it to run until warm.
6. Switch the flow selector switch to 5 or 8 gpm depending on which flow you are testing.
7. With the engine at the programmed speed, the test flow gauge should read 4-6 gpm/15-23 lpm or 7-9 gpm/26.5-34 lpm.
8. Slowly turn the restrictor valve clockwise while watching the pressure gauge. The flow rate should stay at 4-6 gpm/15-23 lpm or 7-9 gpm/26.5-34 lpm as the pressure gauge reaches 2100-2200 psi/148-155 bar.

9. At 2100-2200 psi/148-155 bar, the relief valve should begin to open. The pressure at which the relief valve just begins to open is commonly referred to as the "cracking pressure". At the "cracking pressure," the flow rate should start to drop because the relief valve is allowing fluid to bypass to the hydraulic reservoir. The "cracking pressure" is preset at the factory and if it is not within the above range, the relief valve must be re-set as follows:

- a. The relief valve is located on the right side of the unit just behind the dash panel. It protrudes out from the manifold assembly. Use an open end or box end wrench to loosen the nut on the relief valve.
- b. Use an Allen wrench to adjust the relief valve. Turn clockwise to raise the pressure and counterclockwise to reduce the pressure.
- c. Tighten the nut and retest.



# TROUBLESHOOTING

PROBLEM	CAUSE	REMEDY
Engine will not start.	Flow selector switch not in the OFF position.	Make sure the flow selector switch is in the OFF position when starting.
	Battery not connected.	Attach battery cables, check wires.
	Weak battery.	Test battery, charge or replace.
	No fuel.	Add Fuel.
	Fuel filter plugged.	Replace fuel filter.
	Defective spark plugs.	Remove plugs, check gap, clean or replace.
Fluid blowing out of fluid reservoir vent.	Hydraulic tank overfilled.	Correct the fluid level.
	Pump suction leak.	Check suction connections. Tighten if necessary.
Hydraulic tool won't operate.	Flow selector switch not switched ON.	Check that the flow selector switch is set to 5 or 8 gpm.
	Incorrect hose connection to tool.	Make sure the tool hose circuit goes from left (pressure) fitting to tool and back to the right fitting (return). Fluid always flows from the male to female fittings.
	Quick disconnect fittings defective.	Detach from hose, connect set together and check for free flow.
	Hydraulic fluid level low.	Check for correct fluid level. Fill using the recommended fluid.
	Pump coupling defective.	With the engine not running. Check the coupling between the pump and engine that it is engaged and is not damaged. Caution: Keep hands clear of rotating objects.
	Relief valve stuck open.	Adjust or replace valve.
	Suction hose kinked.	Make sure suction hose from fluid reservoir to pump inlet has a smooth curve.
	Solenoid not working.	Check solenoid operation and electrical connections.
	Tool is defective.	Refer to tool manual.

---

# SPECIFICATIONS

---

Engine: ..... 18 hp Briggs / 20 hp Honda

Capacity..... One 5 gpm/19 lpm Circuit or One 8 gpm/30 lpm Circuit

Length:.....36 in. / 91.4 cm

Width: .....23 in: / 58.4 cm

Height: .....29.5 in. / 74.9cm



Weight (Wet): Single Circuit Briggs ..... 330 lbs / 149.6 kg



Weight (Wet): Single Circuit Honda ..... 348 lbs / 157.8 kg

Fuel Tank Capacity: ..... 7 gal. / 26.5 ltr

Estimated Gas Consumption Per Hour ..... 1.3 gal / 4 ltr

Hydraulic Reservoir Capacity: .....3 gal. / 11 ltr

Relief Valve "crack" setting ..... 2100 psi / 145 bar

Full relief setting ..... 2500 psi / 172 bar



OR



HTMA Category ..... "C" (20 lpm @ 138 bar) or "D" (30 lpm @ 138 bar)

Sound Power Level ..... 100 dBA

Vibration Level..... N/A

# FIGURE 1. BRIGGS ENGINE ASSEMBLY

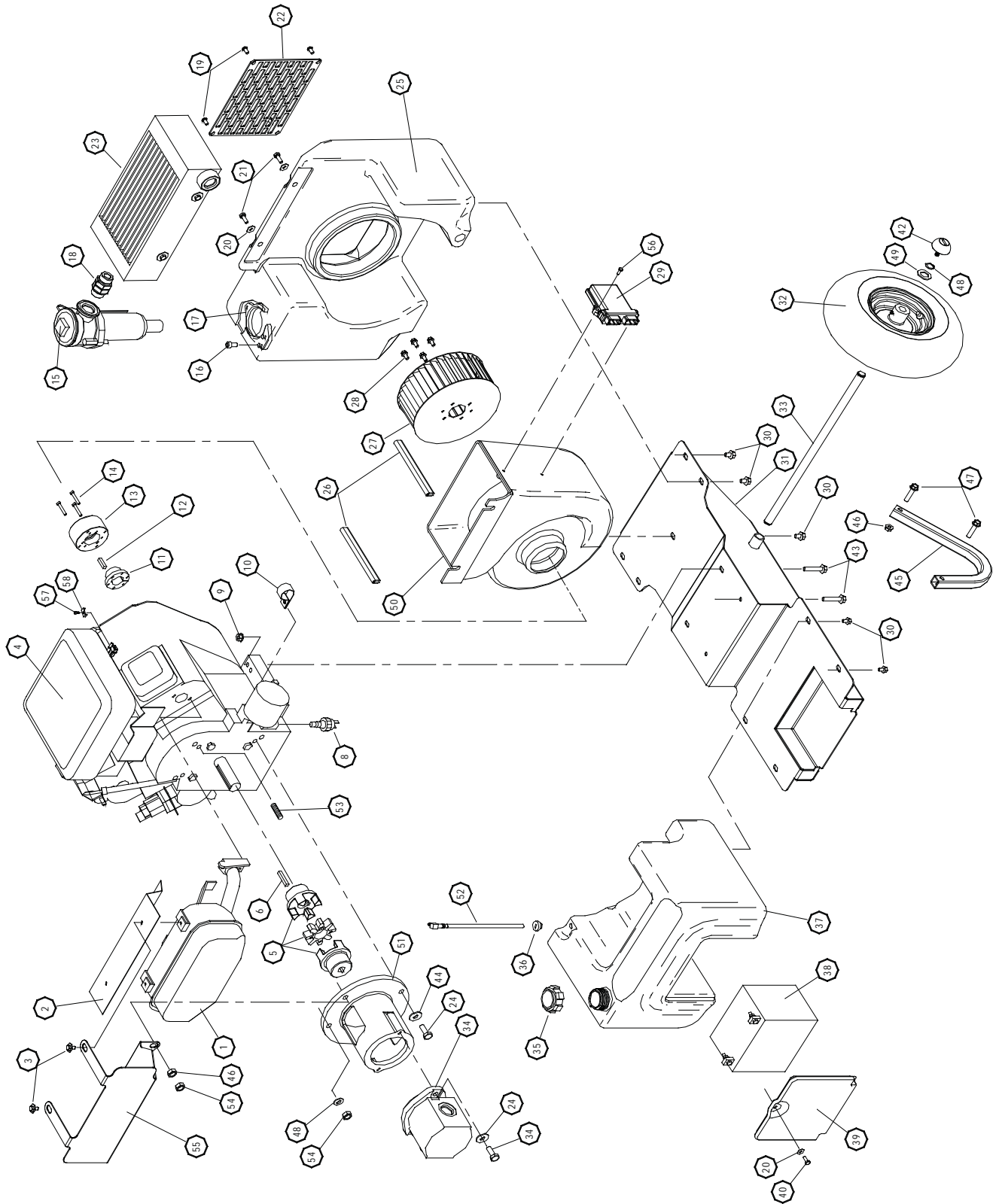

# FIGURE 1. BRIGGS ENGINE PARTS LIST

Item No.	Part No.	Qty	Description
1	36150	1	Muffler
2	36151	1	Heat Shield
3	36152	2	Screw, Hex Washer
4	59007	1	Briggs Engine
5	56656	1	Coupling
6	07819	1	Square Key
7	07860	2	Capscrew, 3/8-16 x 1-1/4
8	31765	1	Pressure Switch
9	12787	4	Flange Nut
10	24287	1	Clamp
11	59076	1	Bushing
12	20990	1	Key
13	59103	1	Blower Hub
14	00753	3	Capscrew
15	40080	1	Filter Assy
16	43687	1	Capscrew
17	64937	1	Grip Plate
18	51292	1	Std Thread Union
19	17821	4	Button Head HS
20	60945	3	Washer, 1/4 in. ID
21	15476	2	Capscrew, 1/2 -20 UNC
22	59080	1	Front Grille
23	59091	1	Cooler
24	07860	2	Capscrew, 3/8
25	59077	1	Hydraulic Tank
26	62296	2	Weather Strip
27	62303	1	Blower Wheel
28	59074	4	Hex Flange Bolt, 1/4 -20
29	65310	1	Engine Controller
30	40433	9	Hex Flange Bolt 5/16-18 x 1/2
31	58897	1	Frame Base Weldment
32	58918	2	Wheel & Tire
33	58917	1	Axle

Item No.	Part No.	Qty	Description
34	04134	1	Pump, Single
35	07810	1	Fuel Cap
36	60920	1	Grommet
37	59078	1	Fuel Tank
38	04303	1	Battery
39	60921	1	Battery Cover
40	15476	1	Capscrew, 1/4-20 x 3/4
41	65068	1	Hex Flange Bolt
42	21714	2	Handle Bumper
43	58942	3	Hex Flange Bolt, 5/16 x 1-3/4
44	01459	4	Lockwasher, 3/8
45	58975	2	Foot
46	18893	4	Flang Nut, 3/8-16
47	58976	4	Hex Flange Bolt, 3/8-16
48	31240	2	Retaining Ring
49	21318	2	Washer, 3/4
50	59083	1	Blower Housing
51	56655	1	Pump Mount
52	60919	1	Fuel Elbow
53	62385	2	Stud
54	371503	1	Nut
55	62324	1	Heat Shield
56	62292	2	Hex Washer Head Screws
57	64991	1	Screw
58	56709	1	Cable Clamp
59	65042	1	Rectifier Wire

# FIGURE 1A. HONDA ENGINE ASSEMBLY

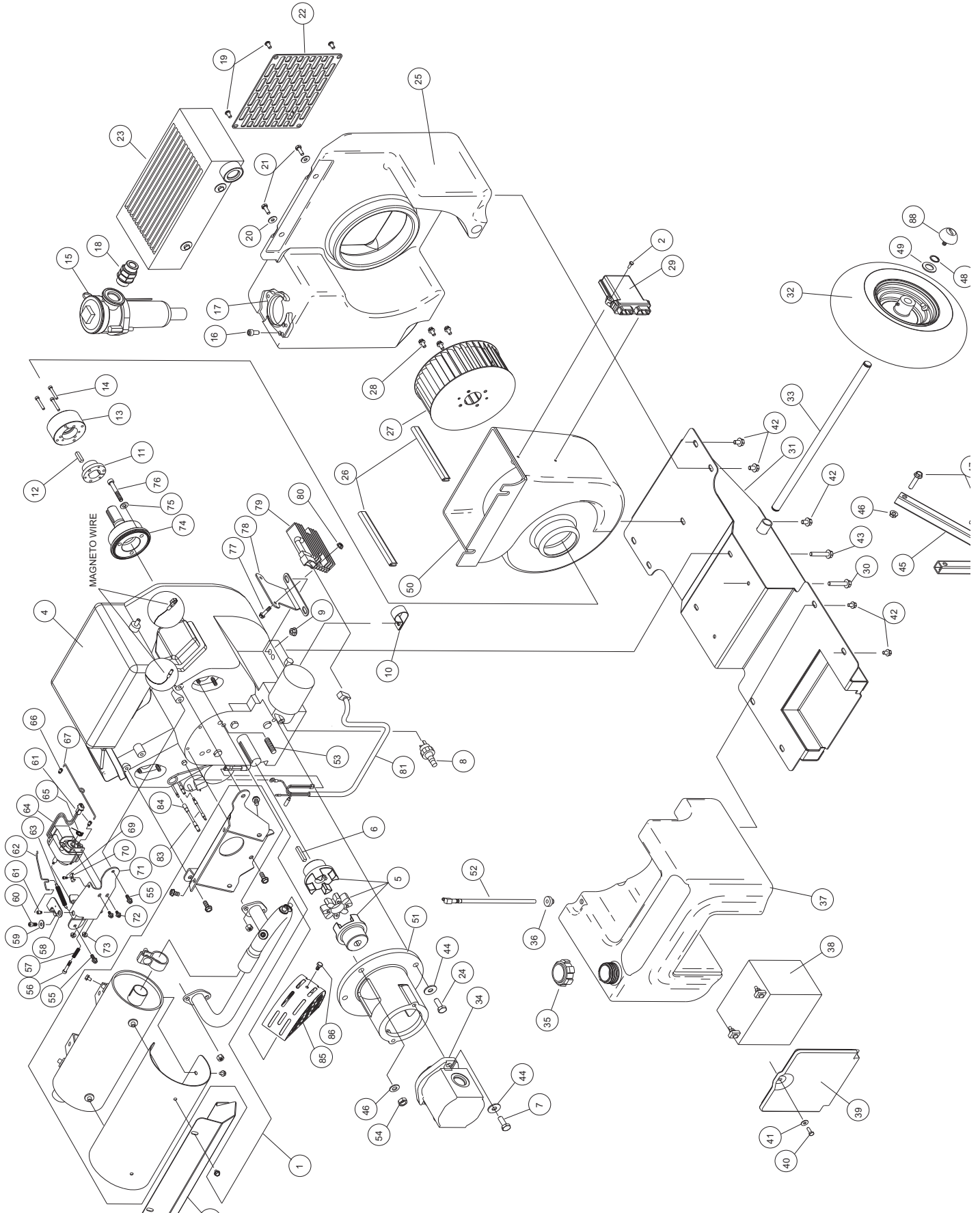

# FIGURE 1A. HONDA ENGINE PARTS LIST

Item No.	Part No.	Qty	Description
1	65294	1	Muffler Kit
2	62292	2	Hex Washer Head Screw
3	---	-	No Item
4	36918	1	Honda Engine
5	56656	1	Coupling
6	07819	1	Square Key
7	07860	2	Capscrew, 3/8-16 x 1-1/4
8	31765	1	Pressure Switch
9	12787	4	Flange Nut, 5/16
10	24287	1	Clamp
11	59076	1	Bushing
12	20990	1	Key
13	59103	1	Blower Hub
14	00753	3	Capscrew, 10-24
15	40080	1	Filter Assy
16	43687	1	Capscrew, M8 x 16
17	64937	1	Grip Plate
18	51292	1	Std Thread Union
19	17821	4	Button Head HS, 1/4 x 20
20	60945	2	Washer, 1/4 in. ID
21	15476	2	Capscrew, 1/2 -20 UNC
22	59080	1	Front Grille
23	59091	1	Cooler
24	07860	2	Capscrew, 3/8-16
25	59077	1	Hydraulic Tank
26	62296	2	Weather Strip
27	62303	1	Blower Wheel
28	59074	4	Hex Flange Bolt, 1/4 -20
29	65082	1	Engine Controller
30	65058	1	Hex Flange Bolt
31	58897	1	Frame Base Weldment
32	58918	2	Wheel & Tire
33	58917	1	Axle
34	04134	1	Pump, Single
35	07810	1	Fuel Cap
36	60920	1	Grommet
37	59078	1	Fuel Tank
38	04303	1	Battery
39	60921	1	Battery Cover
40	15476	1	Capscrew, 1/4-20
41	60945	1	Washer, 1/4
42	40433	9	Hex Flange Bolt, 5/16
43	58942	4	Hex Flange Bolt, 5/16
44	01459	4	Lockwasher, 3/8
45	58975	2	Foot

Item No.	Part No.	Qty	Description
46	18893	4	Flang Nut, 3/8-16
47	58976	4	Hex Flange Bolt, 3/8-16
48	31240	2	Retaining Ring
49	21318	2	Washer, 3/4
50	59083	1	Blower Housing
51	56655	1	Pump Mount
52	60919	1	Fuel Elbow
53	62385	2	Stud
54	371503	1	Nut
55	60972	2	Hex Flange Bolt, M6 x 15
56	49174	1	Screw, M8 x 30
57	62185	1	Spring
58	62179	1	Choke Pivot Weldment
59	60945	1	Washer, 1/4 inch ID
60	60962	1	HSHCS 1/4-20 x 1/2 inch
61	62181	2	Link Retainer
62	62184	1	Choke Link
63	62183	1	Spring
64	62180	1	Rotary Actuator
65	64990	1	Spring, Torsion
66	65072	1	Link Retainer
67	62182	1	Throttle Link
68	----	--	No Item
69	64991	1	Screw, M8 x 12
70	56709	1	Cable Clamp
71	62177	1	Actuator Weldment
72	60970	2	Hex Flange Bolt, M5 x 10
73	60971	2	Flange Nut, 8-32
74	60948	1	Stub Shaft
75	60949	3	Washer
76	60950	3	HSHCS, M8 x 55
77	60953	2	Hex Flange Bolt, 1/4-20 x 1 inch
78	60957	1	Rectifier Bracket
79	---	1	Rectifier (Part of Engine Assy)
80	59095	2	Flange Nut, 1/4-20
81	37294	1	Wire Harness
82	---	-	No Item
83	62404	1	Mag Kill Wire
84	62405	1	Fuel Shutoff Wire
85	---	-	No Item
86	---	-	No Item
87	62325	1	Heat Shield
88	21714	2	Handle Bumper

# FIGURE 2. FRAME PARTS

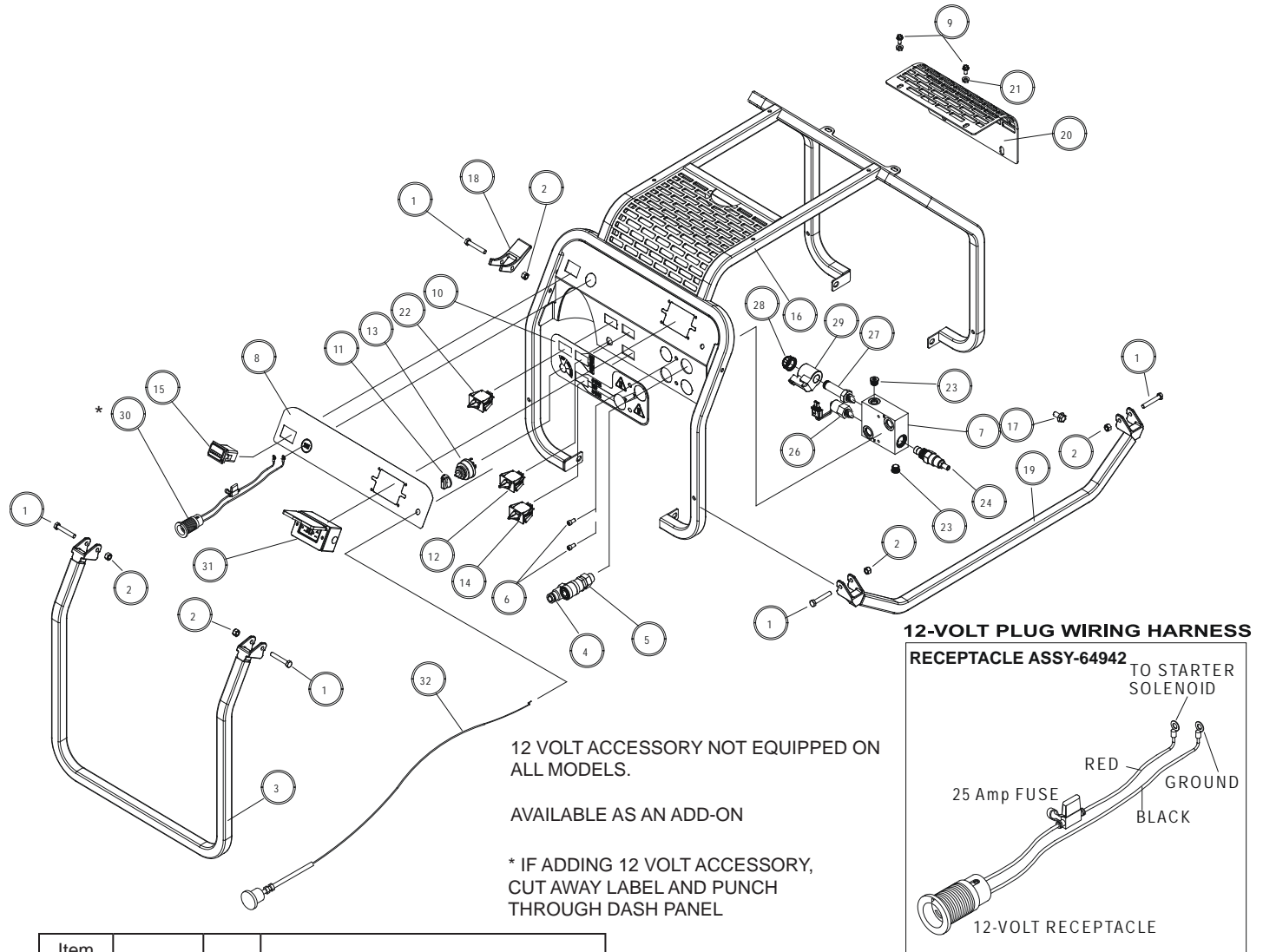

Item No.	Part No.	Qty	Description
1	370502	7	Capscrew, 5/16 in. -18 UNC
2	03906	7	Nylock Nut, 5/16 in. -18 UNC
3	62270	1	Handle, Rear Lift
4	58857	1	Coupler, Male 3/8 in., -8 SAE
5	58856	1	Coupler, Female 3/8 in., -8 SAE
6	60962	2	Capscrew, 1/4 in. -20
7	59130	1	Manifold Assy, Single Circuit
8	62302	1	Dash Decal
	62317	1	Dash Decal, POWERLINK™
9	59074	6	Hex Flange Bolt, 1/4 in. -20
10	62300	1	Decal, Single Circuit
	62305	1	Decal, Single Circuit POWERLINK™
11	60963	1	Knob
12	60955	1	2-Way Switch
13	60954	1	Rotary Switch
14	60956	1	3-Way Switch
15	60946	1	Hour Meter
16	62272	1	Frame Weldment

Item No.	Part No.	Qty	Description
17	23530	2	Hex Flange Bolt, 3/8 in. -16
18	58916	1	Handle Lock
19	62271	2	Lift Handle
20	59079	1	Cooler Guard
21	59095	2	Flange Nut, 1/4 in. -20
22	60955	1	2-Way Switch (on models with POWERLINK™ option only)
23	350045	2	Hollow Hex Plug 6 SAE
24	59131	1	Relief Valve
25	--	-	No Item
26	59128	1	Pressure Switch Assy
27	60959	1	Directional Valve
28	---	1	Cap (Included with Item 27)
29	60958	1	Coil
30	64942	1	12 volt Receptacle Assy
31	62314	1	POWERLINK™ Receptacle
32	62298	1	Choke Cable Assy

# FIGURE 3. HOSES, FITTINGS & CLAMPS

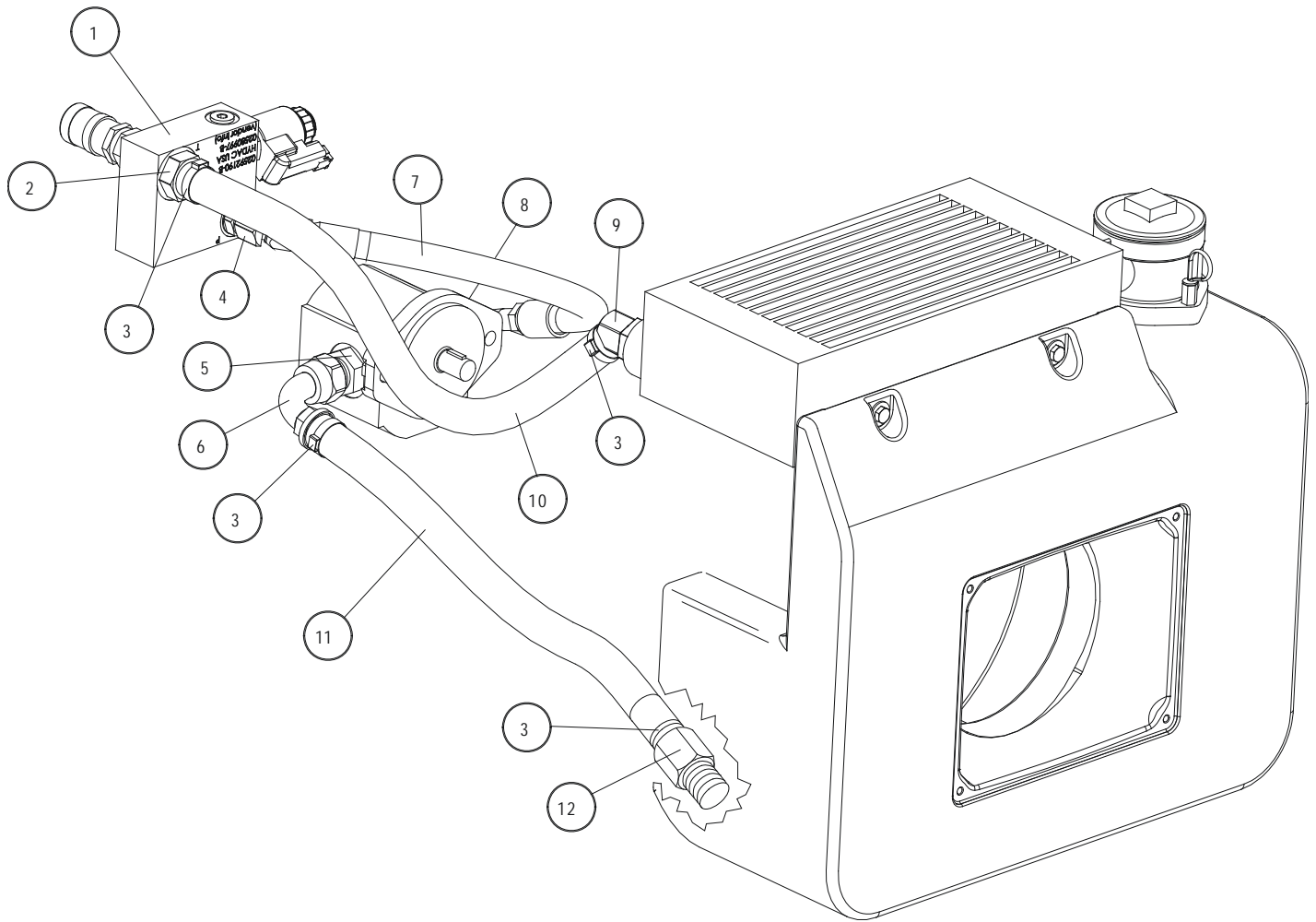

Item No.	Part No.	Qty	Description
1	59130	1	Manifold Assy, Single Circuit
2	59104	1	Hose Barb, 3/4 in. Hose x 3/4 in. Pipe
3	62199	4	Hose Clamp
4	350000	1	Elbow, 45° Straight Thread
5	02773	1	Adapter
6	58569	1	Elbow, 90°
7	58943	1	Hose
8	350104	1	Connector, Straight Thread
9	40364	1	Elbow, 45°
10	59088	1	Hose
11	59089	1	Hose
12	59105	1	Hose Barb, 3/4 in. Hose x 3/4 in. Pipe



# FIGURE 4. ADDITIONAL WIRING DIAGRAM FOR HONDA POWER UNITS ONLY

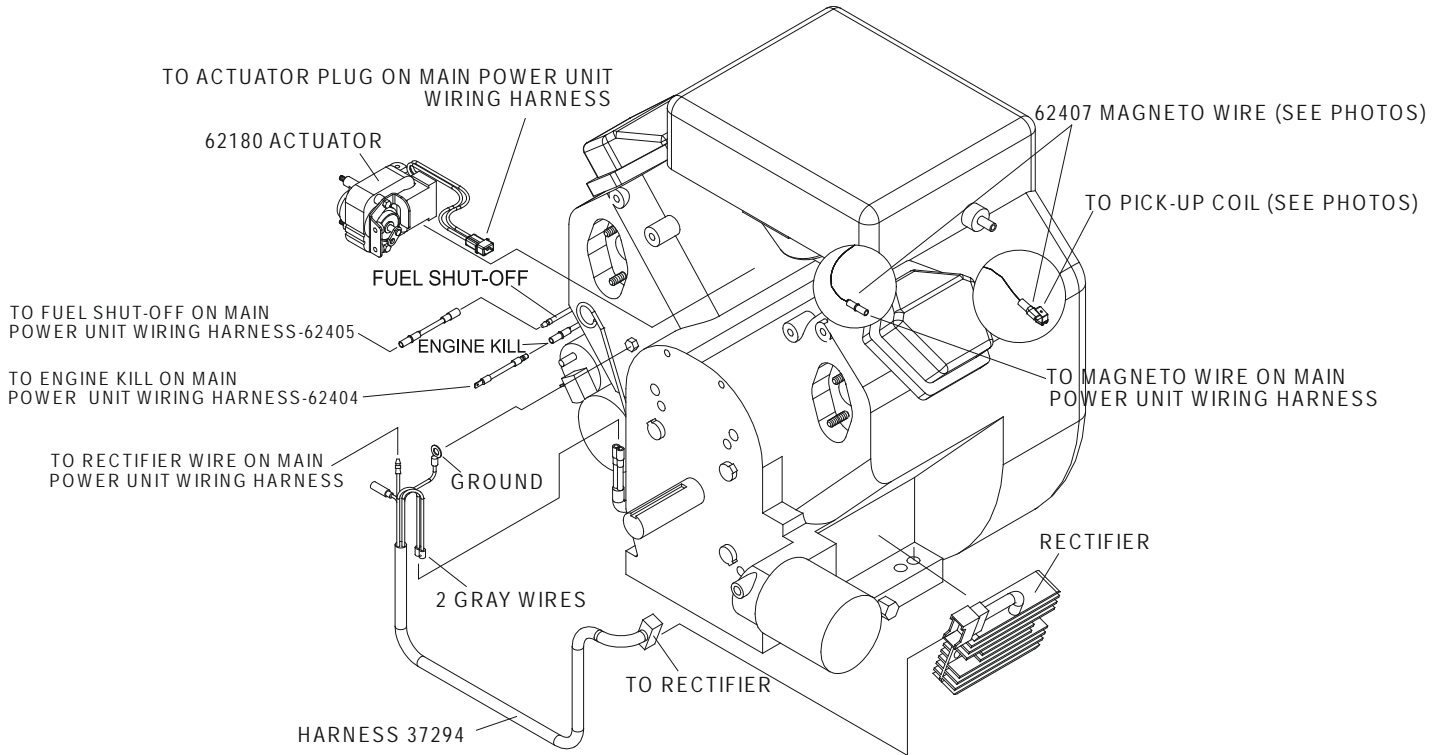

Location of Magnetgo Wire Connection



Fan Cover Removed From Honda Engine

Receptacle with 1/4-inch Double Tab Connected to Pick-up Coil



# FIGURE 4A. POWERLINK™ WIRING DIAGRAM

**ONLY SPECIFIC MODELS WITH BRIGGS & STRATTON ENGINES  
ARE EQUIPPED WITH THE POWER LINK FEATURE**

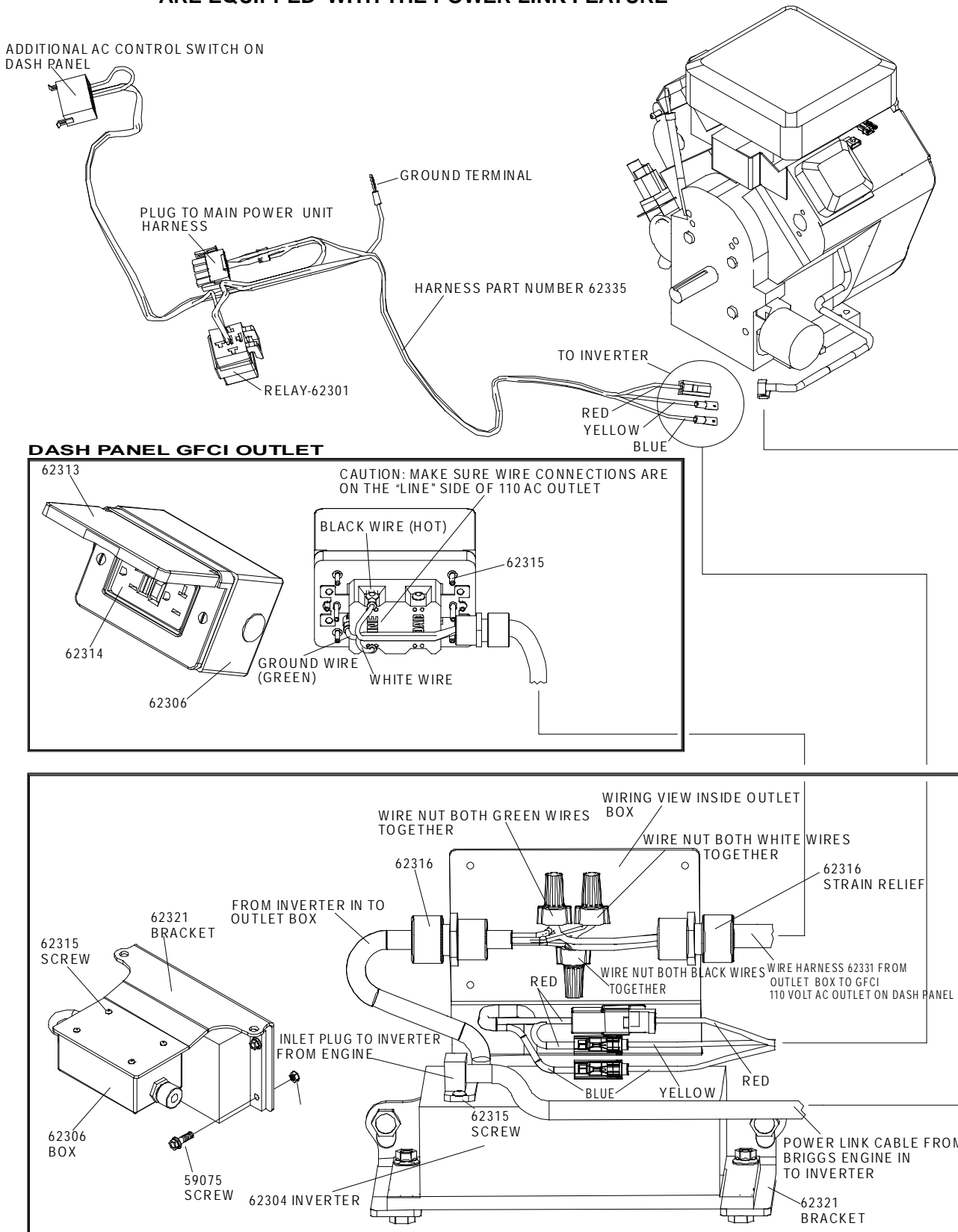

# FIGURE 4B. MAIN POWER UNIT WIRING HARNESS

P/N-65147

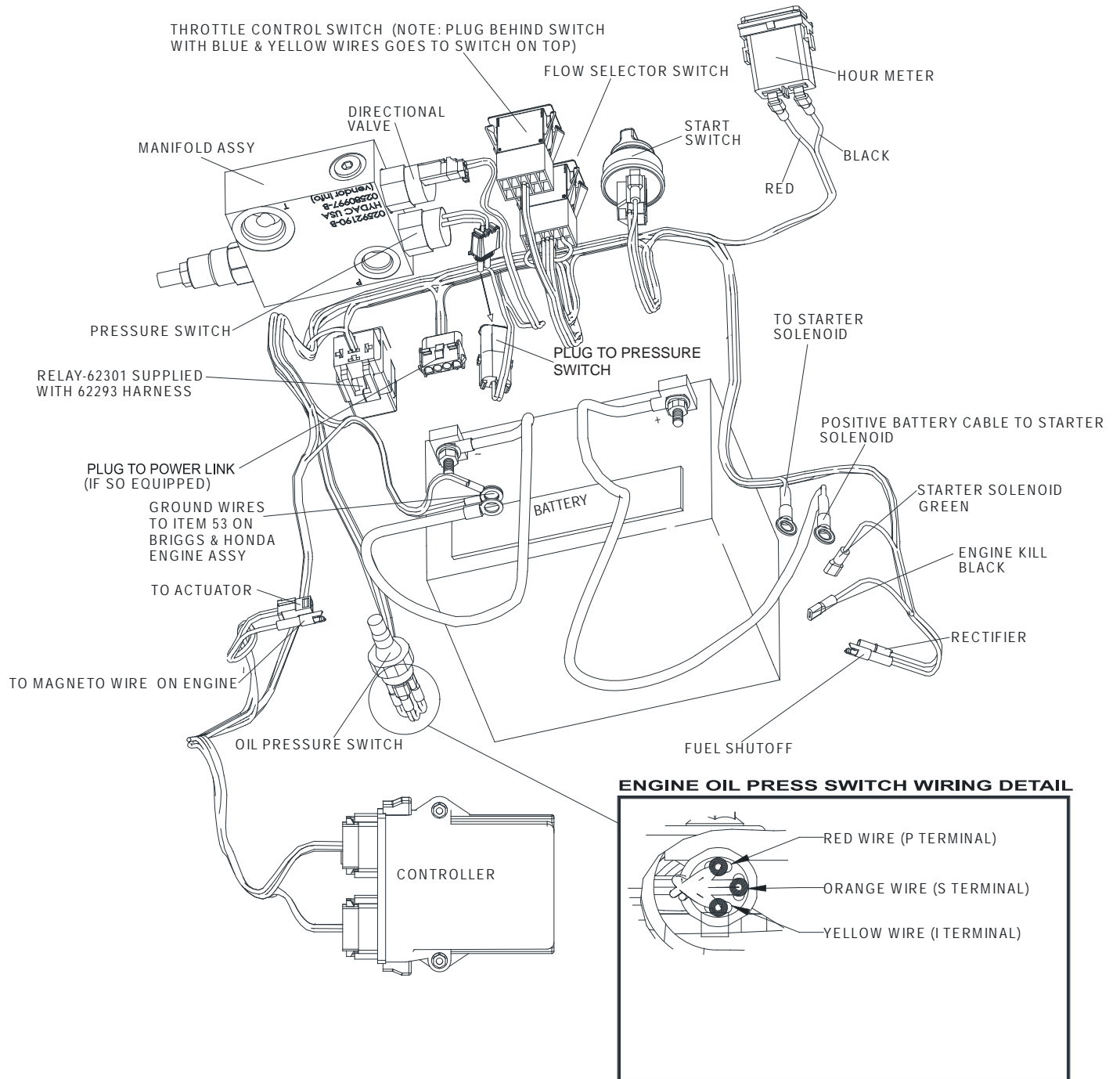

---

# WARRANTY

---

Stanley Hydraulic Tools (hereinafter called "Stanley"), subject to the exceptions contained below, warrants new hydraulic tools for a period of one year from the date of sale to the first retail purchaser, or for a period of 2 years from the shipping date from Stanley, whichever period expires first, to be free of defects in material and/or workmanship at the time of delivery, and will, at its option, repair or replace any tool or part of a tool, or new part, which is found upon examination by a Stanley authorized service outlet or by Stanley's factory in Milwaukie, Oregon to be DEFECTIVE IN MATERIAL AND/OR WORKMANSHIP.

## EXCEPTIONS FROM WARRANTY

**NEW PARTS:** New parts which are obtained individually are warranted, subject to the exceptions herein, to be free of defects in material and/or workmanship at the time of delivery and for a period of 6 months after the date of first usage. Seals and diaphragms are warranted to be free of defects in material and/or workmanship at the time of delivery and for a period of 6 months after the date of first usage or 2 years after the date of delivery, whichever period expires first. Warranty for new parts is limited to replacement of defective parts only. Labor is not covered.

**FREIGHT COSTS:** Freight costs to return parts to Stanley, if requested by Stanley for the purpose of evaluating a warranty claim for warranty credit, are covered under this policy if the claimed part or parts are approved for warranty credit. Freight costs for any part or parts which are not approved for warranty credit will be the responsibility of the individual.

**SEALS & DIAPHRAGMS:** Seals and diaphragms installed in new tools are warranted to be free of defects in material and/or workmanship for a period of 6 months after the date of first usage, or for a period of 2 years from the shipping date from Stanley, whichever period expires first.

**CUTTING ACCESSORIES:** Cutting accessories such as breaker tool bits are warranted to be free of defects in material and or workmanship at the time of delivery only.

**ITEMS PRODUCED BY OTHER MANUFACTURERS:** Components which are not manufactured by Stanley and are warranted by their respective manufacturers.

- a. Costs incurred to remove a Stanley manufactured component in order to service an item manufactured by other manufacturers.

**ALTERATIONS & MODIFICATIONS:** Alterations or modifications to any tool or part. All obligations under this warranty shall be terminated if the new tool or part is altered or modified in any way.

**NORMAL WEAR:** any failure or performance deficiency attributable to normal wear and tear such as tool bushings, retaining pins, wear plates, bumpers, retaining rings and plugs, rubber bushings, recoil springs, etc.

**INCIDENTAL/CONSEQUENTIAL DAMAGES:** To the fullest extent permitted by applicable law, in no event will STANLEY be liable for any incidental, consequential or special damages and/or expenses.

**FREIGHT DAMAGE:** Damage caused by improper storage or freight handling.

**LOSS TIME:** Loss of operating time to the user while the tool(s) is out of service.

**IMPROPER OPERATION:** Any failure or performance deficiency attributable to a failure to follow the guidelines and/or procedures as outlined in the tool's operation and maintenance manual.

**MAINTENANCE:** Any failure or performance deficiency attributable to not maintaining the tool(s) in good operating condition as outlined in the Operation and Maintenance Manual.

**HYDRAULIC PRESSURE & FLOW, HEAT, TYPE OF FLUID:** Any failure or performance deficiency attributable to excess hydraulic pressure, excess hydraulic back-pressure, excess hydraulic flow, excessive heat, or incorrect hydraulic fluid.

**REPAIRS OR ALTERATIONS:** Any failure or performance deficiency attributable to repairs by anyone which in Stanley's sole judgement caused or contributed to the failure or deficiency.

**MIS-APPLICATION:** Any failure or performance deficiency attributable to mis-application. "Mis-application" is defined as usage of products for which they were not originally intended or usage of products in such a manner which exposes them to abuse or accident, without first obtaining the written consent of Stanley. PERMISSION TO APPLY ANY PRODUCT FOR WHICH IT WAS NOT ORIGINALLY INTENDED CAN ONLY BE OBTAINED FROM STANLEY ENGINEERING.

**WARRANTY REGISTRATION:** STANLEY ASSUMES NO LIABILITY FOR WARRANTY CLAIMS SUBMITTED FOR WHICH NO TOOL REGISTRATION IS ON RECORD. In the event a warranty claim is submitted and no tool registration is on record, no warranty credit will be issued without first receiving documentation which proves the sale of the tool or the tools' first date of usage. The term "DOCUMENTATION" as used in this paragraph is defined as a bill of sale, or letter of intent from the first retail customer. A WARRANTY REGISTRATION FORM THAT IS NOT ALSO ON RECORD WITH STANLEY WILL NOT BE ACCEPTED AS "DOCUMENTATION".

## NO ADDITIONAL WARRANTIES OR REPRESENTATIONS

This limited warranty and the obligation of Stanley thereunder is in lieu of all other warranties, expressed or implied including merchantability or fitness for a particular purpose except for that provided herein. There is no other warranty. This warranty gives the purchaser specific legal rights and other rights may be available which might vary depending upon applicable law.



Stanley Hydraulic Tools  
3810 SE Naef Road  
Milwaukie, Oregon  
503-659-5660 / Fax 503-652-1780  
[www.stanleyhydraulic.com](http://www.stanleyhydraulic.com)

---