

INTRODUCTION

Penetrators are used in applications in which a waterproof seal needs to be made between a cable and a pressure vessel. This is often accomplished using a connector set, but if there is no requirement to separate the cable from the equipment, a penetrator may be used. A penetrator generally has fewer seals and may be physically smaller than a connector pair but hard wiring the cable to the equipment may make it less flexible in use than a connector.

We have designed and sold many penetrator products over the years. Those shown on these pages are the current standards. We may be able to provide earlier designs if necessary, but please consider those shown here.

In addition to those shown, we make many custom penetrators based on parameters supplied to us by our customers. If you do not find something that fits your requirements, please contact SEA CON® and we can assist you by recommending an existing design or developing a new one.

DIMENSION DETAILS

PENETRATOR SERIES NPT PENETRATOR

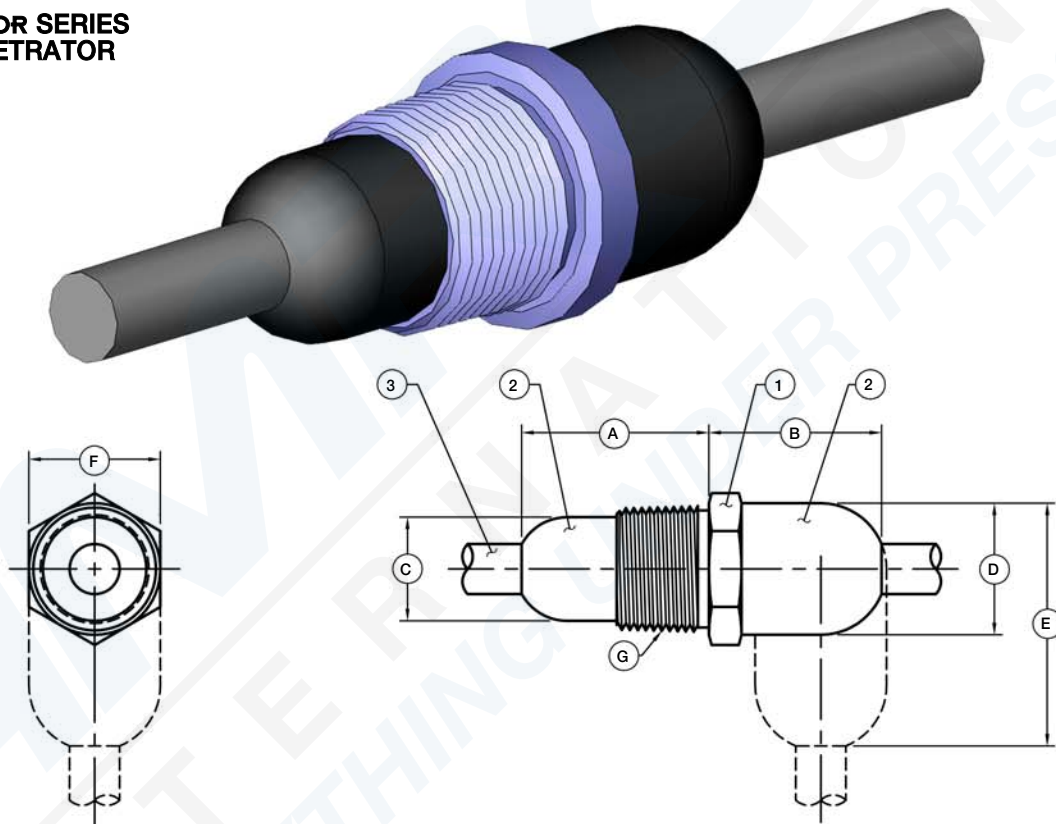

ITEM:

- 1 - NPT PENETRATOR - 316 Stainless Steel.
- 2 - NEOPRENE MOLDING (POLYURETHANE OPTIONAL).
- 3 - CABLE.

PENETRATOR SIZE	A - (INCHES)	B - (INCHES)	C - Ø (INCHES)	D - Ø (INCHES)	E - (INCHES)	F - HEX (INCHES)	G - NPT
1" NPT	1.95	1.80	1.08	1.37	2.8	1.37	1-11 1/2
3/4" NPT	1.70	1.80	0.87	0.93	2.5	1.06	3/4-14
1/2" NPT	1.50	1.80	0.62	0.82	2.0	0.87	1/2-14

NOTES:

- Tin plated contact leads per MIL-T-10727, Type 1, and Fused.
- Hermetic Seal must withstand 10,000 psi test Hydrostatic Pressure.
- Test voltage 800 VAC for 3 seconds minimum without breakdown.
- Maximum contact configuration: 8 PIN.